Ultra Low Noise, High PSRR, 250mA LDO

FEATURES

- Ultra-Low Noise for RF Application
- Ultra-Fast Response in Line/Load Transient
- Quick Start-Up (Typically 100uS)
- Low Quiescent Current: 36uA
- Less than 0.1uA Standby Current When Shutdown
- Low Dropout Voltage: 120mV @ 100mA
- Wide Operating Voltage Ranges : 2.5V to 6V
- TTL-Logic-Controlled Shutdown Input
- Low Temperature Coefficient
- Current Limiting Protection
- Only 1uF Output Capacitor Required
- High Power Supply Rejection Ratio
- ROHS Compliant and 100% Lead (Pb)-Free
- Custom Voltage Available
- Custom Options for CE Logic and Build-in Pull-up/down Available

DESCRIPTION

The FT531xx is designed for portable RF and wireless applications with demanding performance and space requirements. The FT531xx performance is optimized for battery powered systems to deliver ultra low noise and low quiescent current. Regulator ground current increases only slightly in dropout, further prolonging the battery life.

The FT531xx also works with low-ESR ceramic capacitors, reducing the amount of board space necessary for power applications, critical in hand-held wireless devices. The FT531xx consumes less than 0.1uA in shutdown mode and has fast turn-on time less than 100uS. The other features include low dropout voltage, high output accuracy, current limiting protection, and high ripple rejection ratio. The FT531xx is available in the 5-lead of SOT-23-5(L), SC-70 and the 3-lead of SOT-23-3(L), SOT-89-3(L), SOT-23 packages.

APPLICATIONS

- CDMA/GSM Cellular Handsets
- Battery-Powered Equipment
- Laptop, Palmtops, Notebook Computers
- Hand-Held Instruments
- PCMCIA Cards
- Portable Information Appliances

TYPICAL APPLICATION CIRCUIT

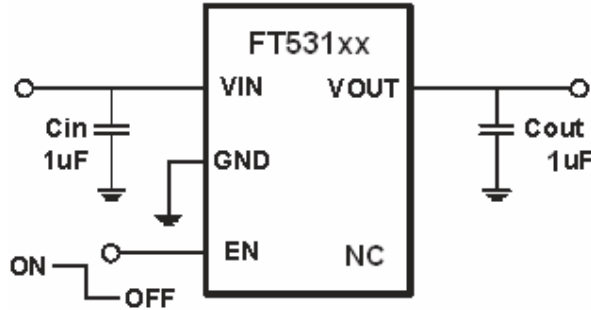

Typical Application Circuit

ABSOLUTE MAXIMUM RATINGS

- ◆ Supply Input Voltage ----- 6V
- ◆ Power Dissipation, PD@ TA=27 °C
 - SOT-23-5(L) ----- 400mW
 - SOT-23-3(L) ----- 400mW
 - SOT-89-3(L) ----- 600mW
 - SC-70 ----- 300mW
 - SOT-23 ----- 250mW
- Package Thermal Resistance
 - SOT-23-5(L)----- 250°C/W
 - SOT-23-3(L)----- 250°C/W
 - SOT-89-3(L)----- 170°C/W
 - SC-70 ----- 330°C/W
 - SOT-23 ----- 380°C/W
- Lead Temperature (Soldering, 10sec.) ----- 260°C
- Storage Temperature Range ----- -60°C to 150°C
- ◆ ESD Susceptibility
 - HBM(Human Body Mode) -----4kV
 - MM(Machine Mode) -----200V

* Stresses exceed those listed under “Absolute Maximum Ratings” may cause permanent damage to the device. Functional operation of the device at conditions beyond those listed in the specification is not guaranteed. Prolonged exposure to extreme conditions may affect device reliability or functionality.

PIN CONFIGURATION

Top View

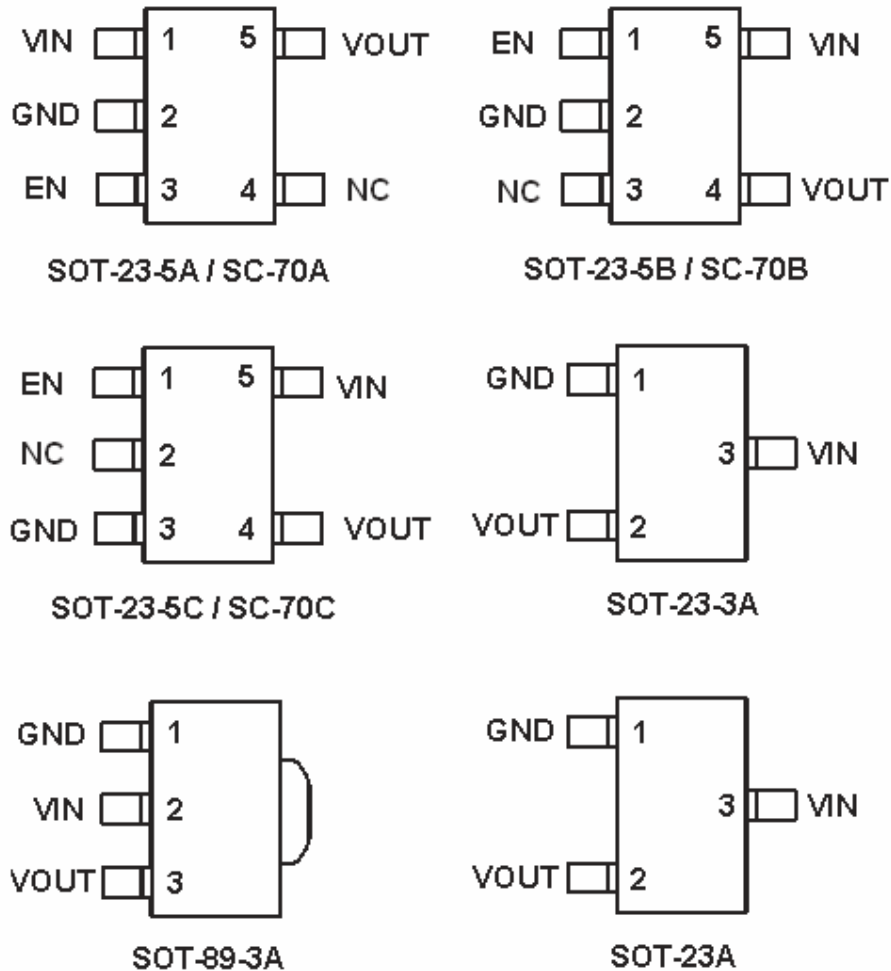

TERMINAL FUNCTION

Pin Name	Pin Function
EN	Chip Enable (Active High). No Pull-Down Resistor Build-in For package SOT-23-3(L) ,SOT-89-3(L) and SOT-23, the EN is internally connected to VIN
VIN	Power Input Voltage
VOUT	Output Voltage
NC	No Connection
GND	Ground

ORDERING INFORMATION

FT531①②

DESIGNATOR	SYMBOL	OUTPUT VOLTAGE
①	A	1.2V
	B	1.3V
	C	1.5V
	D	1.8V
	E	2.5V
	F	2.7V
	G	2.8V
	H	2.85V
	I	3.0V
	J	3.3V
	K	3.6V
	L	4.2V

DESIGNATOR	SYMBOL	PIN CONFIGURATION	PACKAGE TYPE
②	a	SOT-23-5A	SOT-23-5(L)
	b	SOT-23-5B	
	c	SOT-23-5C	
	d	SC-70A	SC-70 / SOT-353
	e	SC-70B	
	f	SC-70C	
	g	SOT-23-3A	SOT-23-3(L)
	h	SOT-23A	SOT-23
	i	SOT-89-3A	SOT-89-3(L)

MARKING RULE

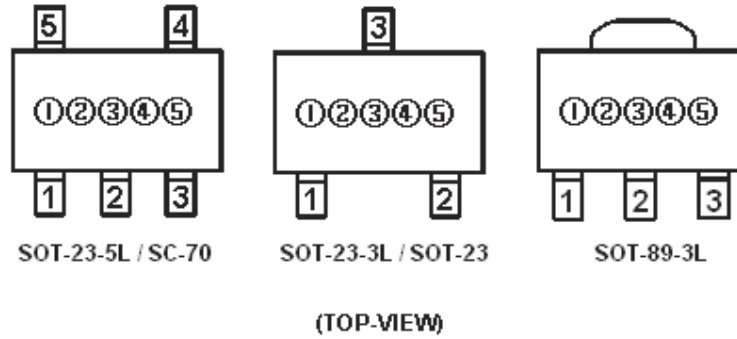

- ① Represent Product Series

SYMBOL	PRODUCT SERIES
6	FT531xx

- ② Represent Output Voltage and operating temperature range
 G represent the output voltage is 2.8V, operating temperature is $-40^{\circ}\text{C} \sim 85^{\circ}\text{C}$.
- ③④⑤ For internal reference.

BLOCK DIAGRAM

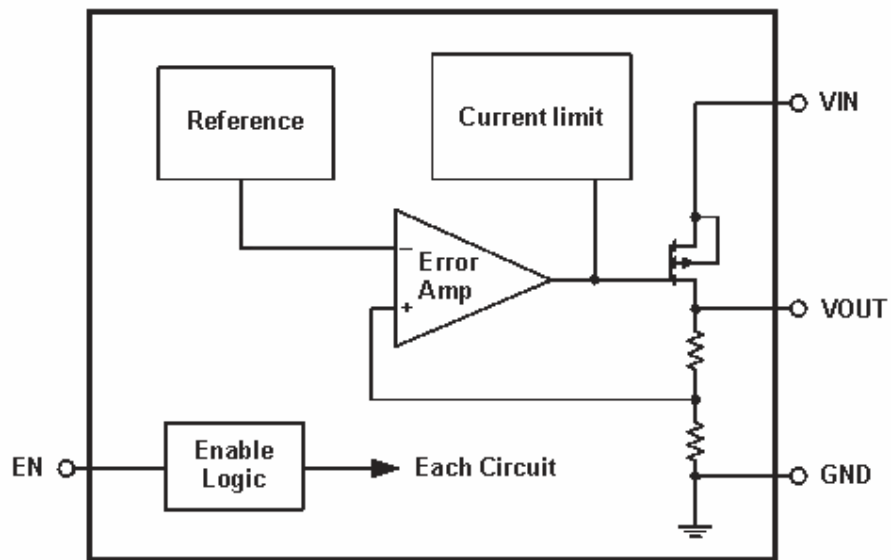

Block Diagram

ELECTRICAL CHARACTERISTICS

Vout=1.2V; En=Vin=2.5V; Cout=1uF unless otherwise noted

PARAMETER	SYMBOL	CONDITIONS	MIN	TYP	MAX	UNITS
Output Voltage Accuracy	Vout	Iout=1mA	-2	---	+2	%
Current Limiter	I _{max}	V _{in} =2.5V	250	300	---	mA
	I _{short}	V _{in} =2.5V	---	20	---	mA
Line Regulations	ΔV _{line}	2.5V~6V	---	0.01	0.3	%/V
Load Regulation	ΔV _{load}	1mA≤I _{out} ≤100mA	---	10	---	mV
Dropout Voltage	V _{drop}	I _{out} =100mA	---	400	---	mV
Supply Current	I _q	V _{in} =2.5V, I _{out} =0mA	---	36	---	uA
Standby Current	I _{stby}	Shut down	---	0.01	1	uA
Temperature Coefficient	ΔV _{out} / (ΔTemp* V _{out})	I _{out} =30mA -40°C≤Temp≤85°C	---	100	---	ppm/°C
Output Noise Voltage	e _{NO}	10Hz~100kHz	---	30	---	uV _{rms}
Ripple Rejection Rate	PSRR@1k	V _{in} =2.5VDC+1Vp-pAC, I _{out} =30mA	---	72	---	dB
	PSRR@10k		---	60	---	
EN Input Bias Current	I _{en}		---	0	100	nA
EN Threshold	VL	---	---	---	0.3	V
	VH	---	1.2	---	6	V

* Dropout voltage is defined as the input to output differential at which the output voltage drops 2% below its nominal value measured at 1V differential.

Vout=1.3V; En=Vin=(Vout+1)V; Cout=1uF unless otherwise noted

PARAMETER	SYMBOL	CONDITIONS	MIN	TYP	MAX	UNITS
Output Voltage Accuracy	Vout	Iout=1mA	-2	---	+2	%
Current Limiter	Imax	Vin=Vout+1V	250	300	---	mA
	Ishort	Vin=Vout+1V	---	20	---	mA
Line Regulations	ΔV_{line}	(Vout+1.0V)~6V	---	0.01	0.3	%/V
Load Regulation	ΔV_{load}	1mA≤Iout≤100mA	---	10	---	mV
Dropout Voltage	Vdrop	Iout=100mA	---	380	---	mV
Supply Current	Iq	Vin=(Vout+1)V,Iout=0mA	---	36	---	uA
Standby Current	Istby	Shut down	---	0.01	1	uA
Temperature Coefficient	$\Delta V_{out} / (\Delta Temp^* V_{out})$	Iout=30mA -40°C≤Temp≤85°C	---	100	---	ppm/°C
Output Noise Voltage	e _{NO}	10Hz~100kHz	---	30	---	uVrms
Ripple Rejection Rate	PSRR@1k	Vin=Vout+1VDC+1Vp-pAC	---	72	---	dB
	PSRR@10k	Iout=30mA	---	60	---	
EN Input Bias Current	Ien		---	0	100	nA
EN Threshold	VL	---	---	---	0.3	V
	VH	---	1.2	---	6	V

* Dropout voltage is defined as the input to output differential at which the output voltage drops 2% below its nominal value measured at 1V differential.

Vout=1.5V; En=Vin=(Vout+1)V; Cout=1uF unless otherwise noted

PARAMETER	SYMBOL	CONDITIONS	MIN	TYP	MAX	UNITS
Output Voltage Accuracy	Vout	Iout=1mA	-2	---	+2	%
Current Limiter	Imax	Vin=Vout+1V	250	300	---	mA
	Ishort	Vin=Vout+1V	---	20	---	mA
Line Regulations	ΔV_{line}	(Vout+1.0V)~6V	---	0.01	0.3	%/V
Load Regulation	ΔV_{load}	1mA≤Iout≤100mA	---	10	---	mV
Dropout Voltage	Vdrop	Iout=100mA	---	300	---	mV
Supply Current	Iq	Vin=(Vout+1)V,Iout=0mA	---	36	---	uA
Standby Current	Istby	Shut down	---	0.01	1	uA
Temperature Coefficient	$\Delta V_{out} / (\Delta Temp^* V_{out})$	Iout=30mA -40°C≤Temp≤85°C	---	100	---	ppm/°C
Output Noise Voltage	e _{NO}	10Hz~100kHz	---	30	---	uVrms
Ripple Rejection Rate	PSRR@1k	Vin=Vout+1VDC+1Vp-pAC Iout=30mA	---	72	---	dB
	PSRR@10k		---	60	---	
EN Input Bias Current	Ien		---	0	100	nA
EN Threshold	VL	---	---	---	0.3	V
	VH	---	1.2	---	6	V

* Dropout voltage is defined as the input to output differential at which the output voltage drops 2% below its nominal value measured at 1V differential.

Vout=1.8V; En=Vin=(Vout+1)V; Cout=1uF unless otherwise noted

PARAMETER	SYMBOL	CONDITIONS	MIN	TYP	MAX	UNITS
Output Voltage Accuracy	Vout	Iout=1mA	-2	---	+2	%
Current Limiter	Imax	Vin=Vout+1V	250	300	---	mA
	Ishort	Vin=Vout+1V	---	20	---	mA
Line Regulations	ΔV_{line}	(Vout+1.0V)~6V	---	0.01	0.3	%/V
Load Regulation	ΔV_{load}	1mA≤Iout≤100mA	---	10	---	mV
Dropout Voltage	Vdrop	Iout=100mA	---	200	---	mV
Supply Current	Iq	Vin=(Vout+1)V,Iout=0mA	---	36	---	uA
Standby Current	Istby	Shut down	---	0.01	1	uA
Temperature Coefficient	$\Delta V_{out} / (\Delta Temp^* V_{out})$	Iout=30mA -40°C≤Temp≤85°C	---	100	---	ppm/°C
Output Noise Voltage	e _{NO}	10Hz~100kHz	---	30	---	uVrms
Ripple Rejection Rate	PSRR@1k	Vin=Vout+1VDC+1Vp-pAC Iout=30mA	---	72	---	dB
	PSRR@10k		---	60	---	
EN Input Bias Current	Ien		---	0	100	nA
EN Threshold	VL	---	---	---	0.3	V
	VH	---	1.2	---	6	V

* Dropout voltage is defined as the input to output differential at which the output voltage drops 2% below its nominal value measured at 1V differential.

Vout=2.5V; En=Vin=(Vout+1)V; Cout=1uF unless otherwise noted

PARAMETER	SYMBOL	CONDITIONS	MIN	TYP	MAX	UNITS
Output Voltage Accuracy	Vout	Iout=1mA	-2	---	+2	%
Current Limiter	Imax	Vin=Vout+1V	250	300	---	mA
	Ishort	Vin=Vout+1V	---	20	---	mA
Line Regulations	ΔV_{line}	(Vout+1.0V)~6V	---	0.01	0.3	%/V
Load Regulation	ΔV_{load}	1mA≤Iout≤100mA	---	10	---	mV
Dropout Voltage	Vdrop	Iout=100mA	---	140	---	mV
Supply Current	Iq	Vin=(Vout+1)V,Iout=0mA	---	36	---	uA
Standby Current	Istby	Shut down	---	0.01	1	uA
Temperature Coefficient	$\Delta V_{out} / (\Delta Temp^* V_{out})$	Iout=30mA -40°C≤Temp≤85°C	---	100	---	ppm/°C
Output Noise Voltage	e _{NO}	10Hz~100kHz	---	40	---	uVrms
Ripple Rejection Rate	PSRR@1k	Vin=Vout+1VDC+1Vp-pAC Iout=30mA	---	72	---	dB
	PSRR@10k		---	60	---	
EN Input Bias Current	Ien		---	0	100	nA
EN Threshold	VL	---	---	---	0.3	V
	VH	---	1.2	---	6	V

* Dropout voltage is defined as the input to output differential at which the output voltage drops 2% below its nominal value measured at 1V differential.

Vout=2.7V; En=Vin=(Vout+1)V; Cout=1uF unless otherwise noted

PARAMETER	SYMBOL	CONDITIONS	MIN	TYP	MAX	UNITS
Output Voltage Accuracy	Vout	Iout=1mA	-2	---	+2	%
Current Limiter	Imax	Vin=Vout+1V	250	300	---	mA
	Ishort	Vin=Vout+1V	---	20	---	mA
Line Regulations	ΔV_{line}	(Vout+1.0V)~6V	---	0.01	0.3	%/V
Load Regulation	ΔV_{load}	1mA≤Iout≤100mA	---	10	---	mV
Dropout Voltage	Vdrop	Iout=100mA	---	130	---	mV
Supply Current	Iq	Vin=(Vout+1)V,Iout=0mA	---	36	---	uA
Standby Current	Istby	Shut down	---	0.01	1	uA
Temperature Coefficient	$\Delta V_{out} / (\Delta Temp^* V_{out})$	Iout=30mA -40°C≤Temp≤85°C	---	100	---	ppm/°C
Output Noise Voltage	e _{NO}	10Hz~100kHz	---	40	---	uVrms
Ripple Rejection Rate	PSRR@1k	Vin=Vout+1VDC+1Vp-pAC Iout=30mA	---	72	---	dB
	PSRR@10k		---	60	---	
EN Input Bias Current	Ien		---	0	100	nA
EN Threshold	VL	---	---	---	0.3	V
	VH	---	1.2	---	6	V

* Dropout voltage is defined as the input to output differential at which the output voltage drops 2% below its nominal value measured at 1V differential.

Vout=2.8V; En=Vin=(Vout+1)V; Cout=1uF unless otherwise noted

PARAMETER	SYMBOL	CONDITIONS	MIN	TYP	MAX	UNITS
Output Voltage Accuracy	Vout	Iout=1mA	-2	---	+2	%
Current Limiter	Imax	Vin=Vout+1V	250	300	---	mA
	Ishort	Vin=Vout+1V	---	20	---	mA
Line Regulations	ΔV_{line}	(Vout+1.0V)~6V	---	0.01	0.3	%/V
Load Regulation	ΔV_{load}	1mA≤Iout≤100mA	---	10	---	mV
Dropout Voltage	Vdrop	Iout=100mA	---	120	---	mV
Supply Current	Iq	Vin=(Vout+1)V,Iout=0mA	---	36	---	uA
Standby Current	Istby	Shut down	---	0.01	1	uA
Temperature Coefficient	$\frac{\Delta V_{out}}{\Delta Temp^*}$ Vout)	Iout=30mA -40°C≤Temp≤85°C	---	100	---	ppm/°C
Output Noise Voltage	e _{NO}	10Hz~100kHz	---	40	---	uVrms
Ripple Rejection Rate	PSRR@1k	Vin=Vout+1VDC+1Vp-pAC Iout=30mA	---	72	---	dB
	PSRR@10k		---	60	---	
EN Input Bias Current	Ien		---	0	100	nA
EN Threshold	VL	---	---	---	0.3	V
	VH	---	1.2	---	6	V

* Dropout voltage is defined as the input to output differential at which the output voltage drops 2% below its nominal value measured at 1V differential.

Vout=2.85V; En=Vin=(Vout+1)V; Cout=1uF unless otherwise noted

PARAMETER	SYMBOL	CONDITIONS	MIN	TYP	MAX	UNITS
Output Voltage Accuracy	Vout	Iout=1mA	-2	---	+2	%
Current Limiter	Imax	Vin=Vout+1V	250	300	---	mA
	Ishort	Vin=Vout+1V	---	20	---	mA
Line Regulations	ΔV_{line}	(Vout+1.0V)~6V	---	0.01	0.3	%/V
Load Regulation	ΔV_{load}	1mA≤Iout≤100mA	---	10	---	mV
Dropout Voltage	Vdrop	Iout=100mA	---	120	---	mV
Supply Current	Iq	Vin=(Vout+1)V,Iout=0mA	---	36	---	uA
Standby Current	Istby	Shut down	---	0.01	1	uA
Temperature Coefficient	$\Delta V_{out} / (\Delta Temp^* V_{out})$	Iout=30mA -40°C≤Temp≤85°C	---	100	---	ppm/°C
Output Noise Voltage	e _{NO}	10Hz~100kHz	---	40	---	uVrms
Ripple Rejection Rate	PSRR@1k	Vin=Vout+1VDC+1Vp-pAC Iout=30mA	---	72	---	dB
	PSRR@10k		---	60	---	
EN Input Bias Current	Ien		---	0	100	nA
EN Threshold	VL	---	---	---	0.3	V
	VH	---	1.2	---	6	V

* Dropout voltage is defined as the input to output differential at which the output voltage drops 2% below its nominal value measured at 1V differential.

Vout=3.0V; En=Vin=(Vout+1)V; Cout=1uF unless otherwise noted

PARAMETER	SYMBOL	CONDITIONS	MIN	TYP	MAX	UNITS
Output Voltage Accuracy	Vout	Iout=1mA	-2	---	+2	%
Current Limiter	Imax	Vin=Vout+1V	250	300	---	mA
	Ishort	Vin=Vout+1V	---	20	---	mA
Line Regulations	ΔV_{line}	(Vout+1.0V)~6V	---	0.01	0.3	%/V
Load Regulation	ΔV_{load}	1mA≤Iout≤100mA	---	10	---	mV
Dropout Voltage	Vdrop	Iout=100mA	---	120	---	mV
Supply Current	Iq	Vin=(Vout+1)V,Iout=0mA	---	36	---	uA
Standby Current	Istby	Shut down	---	0.01	1	uA
Temperature Coefficient	$\Delta V_{out} / (\Delta Temp^* V_{out})$	Iout=30mA -40°C≤Temp≤85°C	---	100	---	ppm/°C
Output Noise Voltage	e _{NO}	10Hz~100kHz	---	40	---	uVrms
Ripple Rejection Rate	PSRR@1k	Vin=Vout+1VDC+1Vp-pAC Iout=30mA	---	72	---	dB
	PSRR@10k		---	60	---	
EN Input Bias Current	Ien		---	0	100	nA
EN Threshold	VL	---	---	---	0.3	V
	VH	---	1.2	---	6	V

* Dropout voltage is defined as the input to output differential at which the output voltage drops 2% below its nominal value measured at 1V differential.

Vout=3.3V; En=Vin=(Vout+1)V; Cout=1uF unless otherwise noted

PARAMETER	SYMBOL	CONDITIONS	MIN	TYP	MAX	UNITS
Output Voltage Accuracy	Vout	Iout=1mA	-2	---	+2	%
Current Limiter	Imax	Vin=Vout+1V	250	300	---	mA
	Ishort	Vin=Vout+1V	---	20	---	mA
Line Regulations	ΔV_{line}	(Vout+1.0V)~6V	---	0.01	0.3	%/V
Load Regulation	ΔV_{load}	1mA≤Iout≤100mA	---	10	---	mV
Dropout Voltage	Vdrop	Iout=100mA	---	120	---	mV
Supply Current	Iq	Vin=(Vout+1)V,Iout=0mA	---	36	---	uA
Standby Current	Istby	Shut down	---	0.01	1	uA
Temperature Coefficient	$\frac{\Delta V_{out}}{\Delta Temp^*}$ Vout)	Iout=30mA -40°C≤Temp≤85°C	---	100	---	ppm/°C
Output Noise Voltage	e _{NO}	10Hz~100kHz	---	40	---	uVrms
Ripple Rejection Rate	PSRR@1k	Vin=Vout+1VDC+1Vp-pAC Iout=30mA	---	72	---	dB
	PSRR@10k		---	60	---	
EN Input Bias Current	Ien		---	0	100	nA
EN Threshold	VL	---	---	---	0.3	V
	VH	---	1.2	---	6	V

* Dropout voltage is defined as the input to output differential at which the output voltage drops 2% below its nominal value measured at 1V differential.

Vout=3.6V; En=Vin=(Vout+1)V; Cout=1uF unless otherwise noted

PARAMETER	SYMBOL	CONDITIONS	MIN	TYP	MAX	UNITS
Output Voltage Accuracy	Vout	Iout=1mA	-2	---	+2	%
Current Limiter	Imax	Vin=Vout+1V	250	300	---	mA
	Ishort	Vin=Vout+1V	---	20	---	mA
Line Regulations	ΔV_{line}	(Vout+1.0V)~6V	---	0.01	0.3	%/V
Load Regulation	ΔV_{load}	1mA≤Iout≤100mA	---	10	---	mV
Dropout Voltage	Vdrop	Iout=100mA	---	120	---	mV
Supply Current	Iq	Vin=(Vout+1)V,Iout=0mA	---	36	---	uA
Standby Current	Istby	Shut down	---	0.01	1	uA
Temperature Coefficient	$\Delta V_{out} / (\Delta Temp^* V_{out})$	Iout=30mA -40°C≤Temp≤85°C	---	100	---	ppm/°C
Output Noise Voltage	e _{NO}	10Hz~100kHz	---	40	---	uVrms
Ripple Rejection Rate	PSRR@1k	Vin=Vout+1VDC+1Vp-pAC Iout=30mA	---	72	---	dB
	PSRR@10k		---	60	---	
EN Input Bias Current	Ien		---	0	100	nA
EN Threshold	VL	---	---	---	0.3	V
	VH	---	1.2	---	6	V

* Dropout voltage is defined as the input to output differential at which the output voltage drops 2% below its nominal value measured at 1V differential.

TYPICAL PERFORMANCE CHARACTERISTICS FT531I

Vin=4.0V, Vout=3.0V, Co=1uF, temp=27°C unless otherwise noted

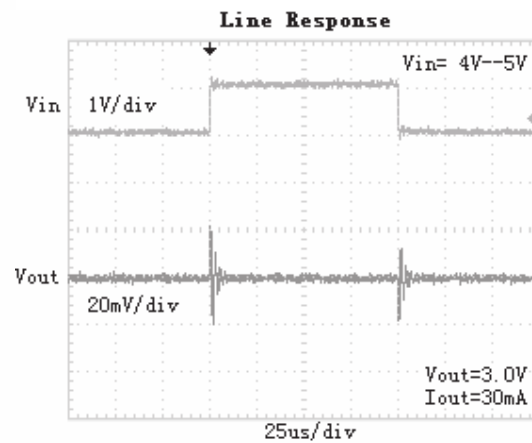
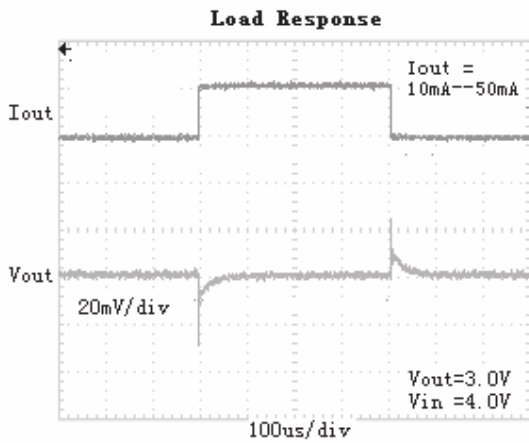
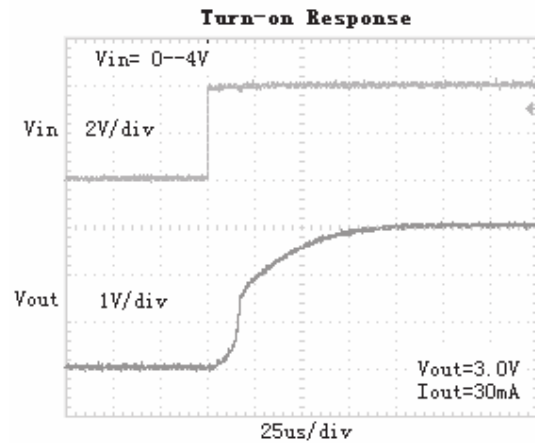
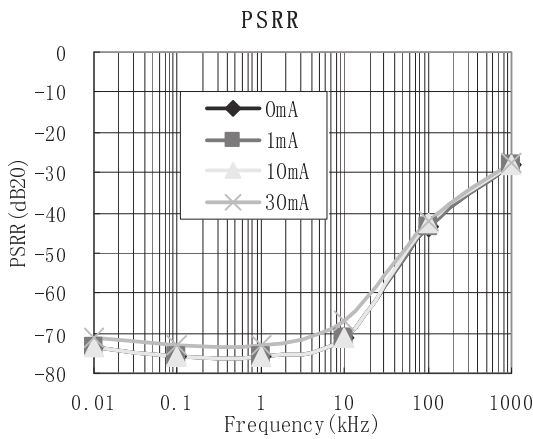
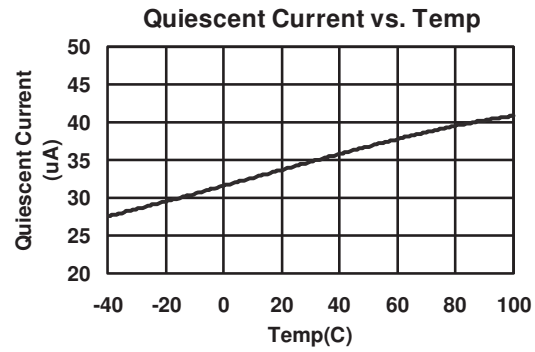
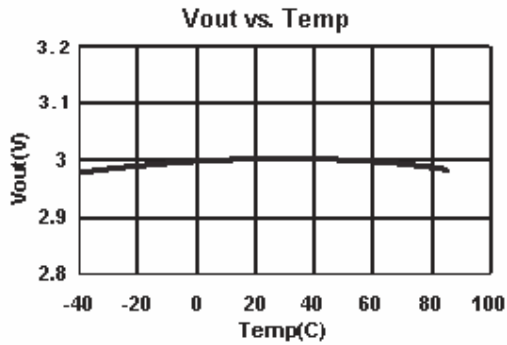

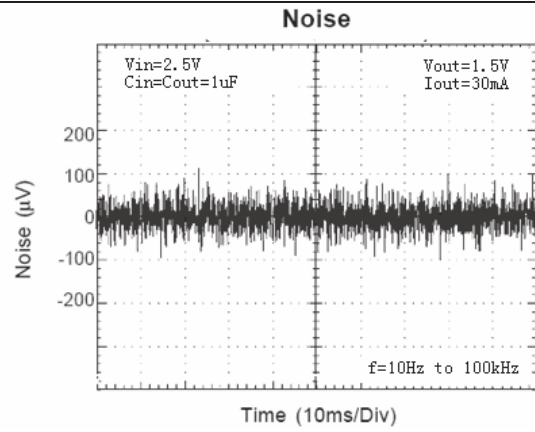
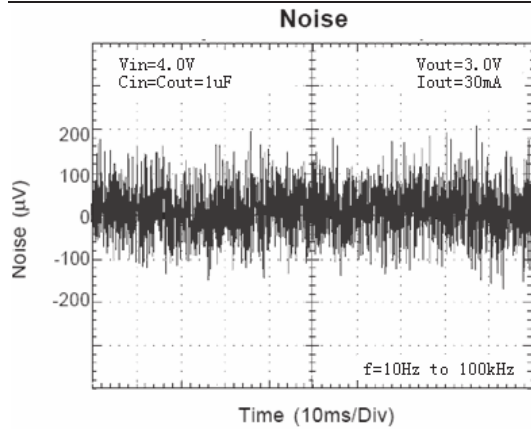

PAKAGING INFORMATION

SOT-23-5L

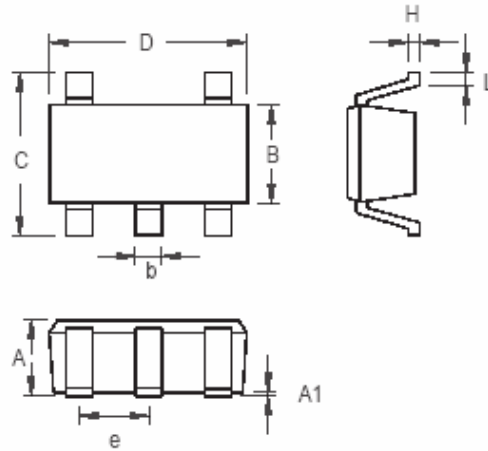

Symbol	Dimensions In Millimeters		Dimensions In Inches	
	Min	Max	Min	Max
A	0.889	1.295	0.035	0.051
A1	0.000	0.152	0.000	0.006
B	1.397	1.803	0.055	0.071
b	0.356	0.559	0.014	0.022
C	2.591	2.997	0.102	0.118
D	2.692	3.099	0.106	0.122
e	0.838	1.041	0.033	0.041
H	0.080	0.254	0.003	0.010
L	0.300	0.610	0.012	0.024

SOT-23-5 Surface Mount Package

SOT-23-3L

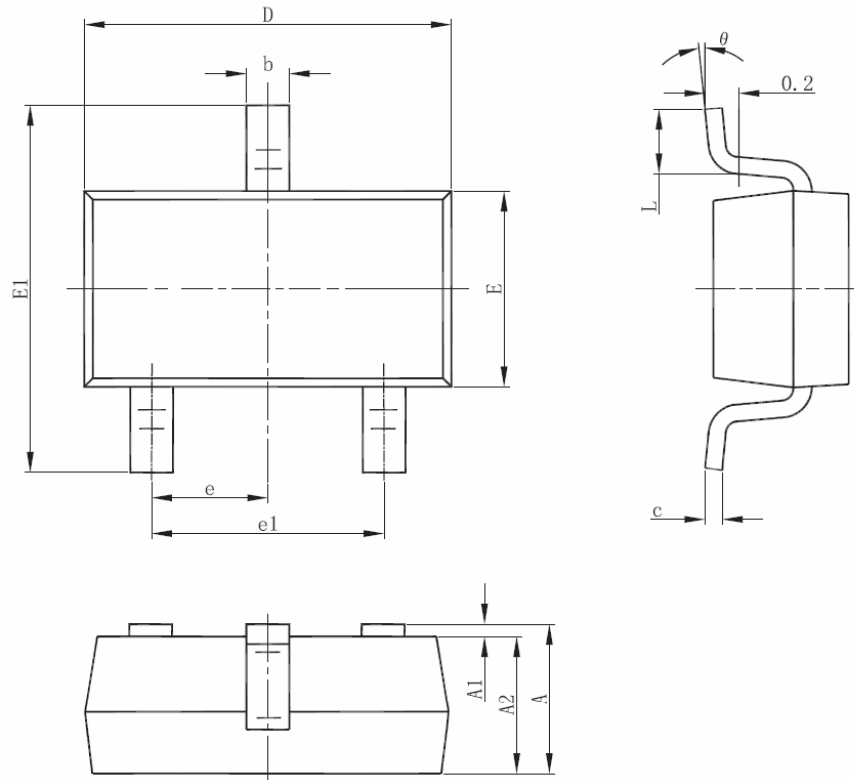

Symbol	Dimensions In Millimeters		Dimensions In Inches	
	Min	Max	Min	Max
A	1.050	1.250	0.041	0.049
A1	0.000	0.100	0.000	0.004
A2	1.050	1.150	0.041	0.045
b	0.300	0.500	0.012	0.020
c	0.100	0.200	0.004	0.008
D	2.820	3.020	0.111	0.119
E	1.500	1.700	0.059	0.067
E1	2.650	2.950	0.104	0.116
e	0.950(BSC)		0.037(BSC)	
e1	1.800	2.000	0.071	0.079
L	0.300	0.600	0.012	0.024
θ	0°	8°	0°	8°

SOT-89-3L

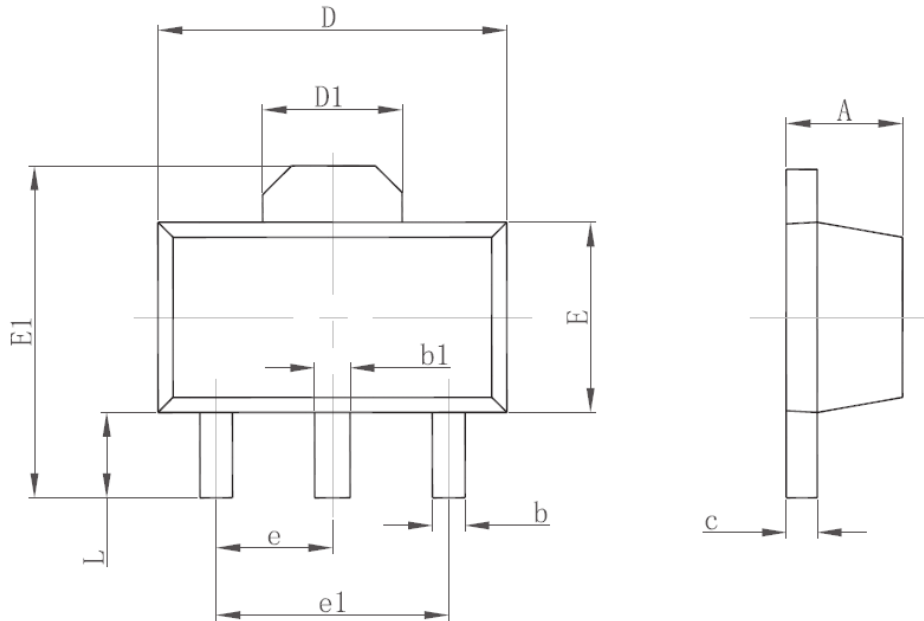

Symbol	Dimensions In Millimeters		Dimensions In Inches	
	Min	Max	Min	Max
A	1.400	1.600	0.055	0.063
b	0.320	0.520	0.013	0.020
b1	0.400	0.580	0.016	0.023
c	0.350	0.440	0.014	0.017
D	4.400	4.600	0.173	0.181
D1	1.550 REF.		0.061 REF.	
E	2.300	2.600	0.091	0.102
E1	3.940	4.250	0.155	0.167
e	1.500 TYP.		0.060 TYP.	
e1	3.000 TYP.		0.118 TYP.	
L	0.900	1.200	0.035	0.047

SC-70

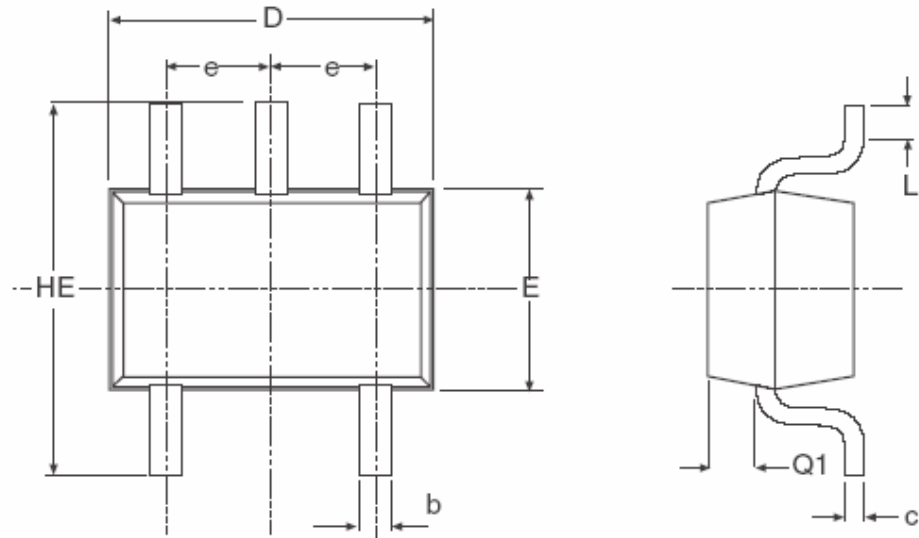

- NOTE:
1. All dimensions are in inches/(millimeters)
 2. Dimensions are inclusive of plating
 3. Dimensions are exclusive of mold flash & metal burr
 4. All specifications comply to EIAJ SC70

SYMBOL	MIN	MAX
e	0.026BSC/(0.65 BSC)	
D	0.071/(1.80)	0.067/(2.20)
b	0.006/(0.15)	0.012/(0.30)
E	0.045/(1.15)	0.053/(1.35)
HE	0.071(1.80)	0.094(2.40)
Q1	0.004/(0.10)	0.016/(0.40)
A2	0.031/(0.80)	0.039/(1.00)
A1	0.000/(0.00)	0.004/(0.10)
A	0.031/(0.80)	0.043/(1.10)
c	0.004/(0.10)	0.007/(0.18)
L	0.004/(0.10)	0.012/(0.30)

SOT-23

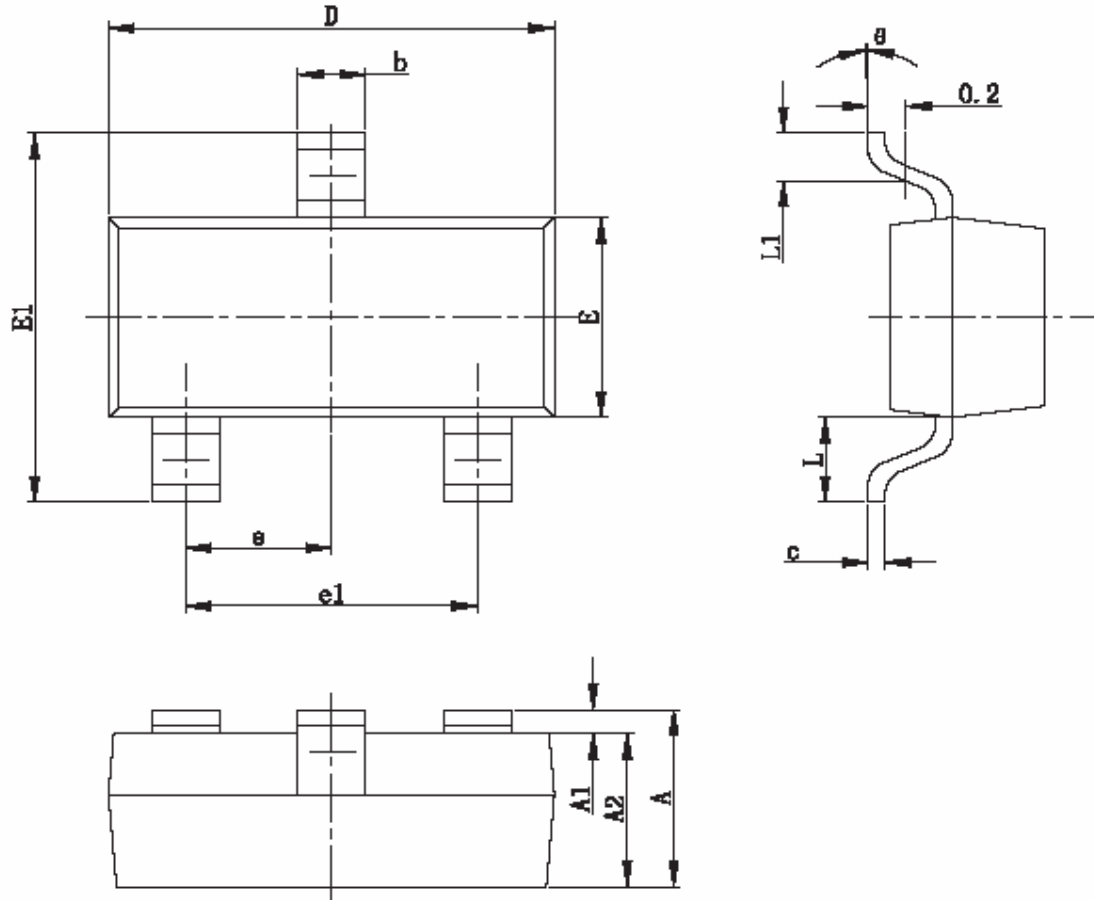

Symbol	Dimensions In Millimeters		Dimensions In Inches	
	Min	Max	Min	Max
A	0.900	1.100	0.035	0.043
A1	0.000	0.100	0.000	0.004
A2	0.900	1.000	0.035	0.039
b	0.300	0.500	0.012	0.020
c	0.080	0.150	0.003	0.006
D	2.800	3.000	0.110	0.118
E	1.200	1.400	0.047	0.055
E1	2.250	2.550	0.089	0.100
e	0.950TYP		0.037TYP	
e1	1.800	2.000	0.071	0.079
L	0.550REF		0.022REF	
L1	0.300	0.500	0.012	0.020
θ	0°	8°	0°	8°