

User's Guide

LMK5B33414EVM User's Guide



ABSTRACT

The LMK5B33414EVM is an evaluation module for the LMK5B33414 Network Clock Generator and Synchronizer. The EVM can be used for device evaluation, compliance testing, and system prototyping.

Table of Contents

1 Introduction	2
2 EVM Quick Start	4
3 EVM Configuration	6
3.1 Power Supply	8
3.2 Logic Inputs and Outputs	9
3.3 Switching Between I2C and SPI	10
3.4 Generating SYSREF Request	11
3.5 XO Input	11
3.6 Reference Clock Inputs	13
3.7 Clock Outputs	13
3.8 Status Outputs and LEDs	13
3.9 Requirements for Making Measurements	14
3.10 Typical Phase Noise Characteristics	15
4 EVM Schematics	16
4.1 Power Supply Schematic	16
4.2 Alternative Power Supply Schematic	16
4.3 Power Distribution Schematic	17
4.4 LMK5B33414 and Input Reference Inputs IN0 to IN1 Schematic	18
4.5 Clock Outputs OUT0 to OUT3 Schematic	19
4.6 Clock Outputs OUT4 to OUT9 Schematic	20
4.7 Clock Outputs OUT10 to OUT13 and Clock Inputs IN2 and IN3 Schematic	21
4.8 XO Schematic	22
4.9 Logic I/O Interfaces Schematic	23
4.10 USB2ANY Schematic	24
5 EVM Bill of Materials	25
5.1 Loop Filter and Vibration Nonsensitive Capacitors	31
6 Appendix A - TICS Pro LMK5B33414 Software	32
6.1 Using the Start Page	32
6.2 Using the Status Page	35
6.3 Using the Input Page	36
6.4 Using APLL1, APLL2, and APLL3 Pages	38
6.5 Using the DPLL1, DPLL2, and DPLL3 Pages	41
6.6 Using the Validation Page	43
6.7 Using the GPIO Page	43
6.8 SYNC/SYSREF/1-PPS Page	44
6.9 Using the Outputs Page	44
6.10 EEPROM Page	46
6.11 Design Report Page	47
7 Revision History	47

Trademarks

All trademarks are the property of their respective owners.

1 Introduction

Overview

The LMK5B33414EVM is an evaluation module for the LMK5B33414 Network Clock Generator and Synchronizer. The EVM can be used for device evaluation, compliance testing, and system prototyping. The LMK5B33414 integrates three Analog PLLs (APLL) and three Digital PLLs (DPLL) with programmable loop bandwidth. The EVM includes SMA connectors for clock inputs, optional off-board APLL reference input, and clock outputs to interface the device with 50- Ω test equipment. The onboard TCXO allows for improved performance when using low DPLL loop bandwidths below 10 Hz and when evaluating holdover, locked, or free-run operational modes. The EVM can be configured through the onboard USB microcontroller (MCU) interface using a PC with TI's TICS Pro software graphical user interface (GUI). TICS Pro can be used to program the LMK5B33414 registers.

Features

- LMK5B33414

What is Included

- LMK5B33414EVM
- 3-ft. mini-USB cable (MPN 3021003-03)

What is Needed

- Windows PC with [TICS Pro Software GUI](#)
- Test Equipment
 - DC power supply (12 V, 1 A)

What is Recommended

- Test equipment:
 - Signal source analyzer
 - Signal generator / reference clock
 - Real-time oscilloscope
 - Precision frequency counter

Figure 1-1 shows the jumper position with red markings. Figure 1-1 shows the DIP switch positions in either green boxes (for ON) or red boxes (for OFF) in the appropriate location.

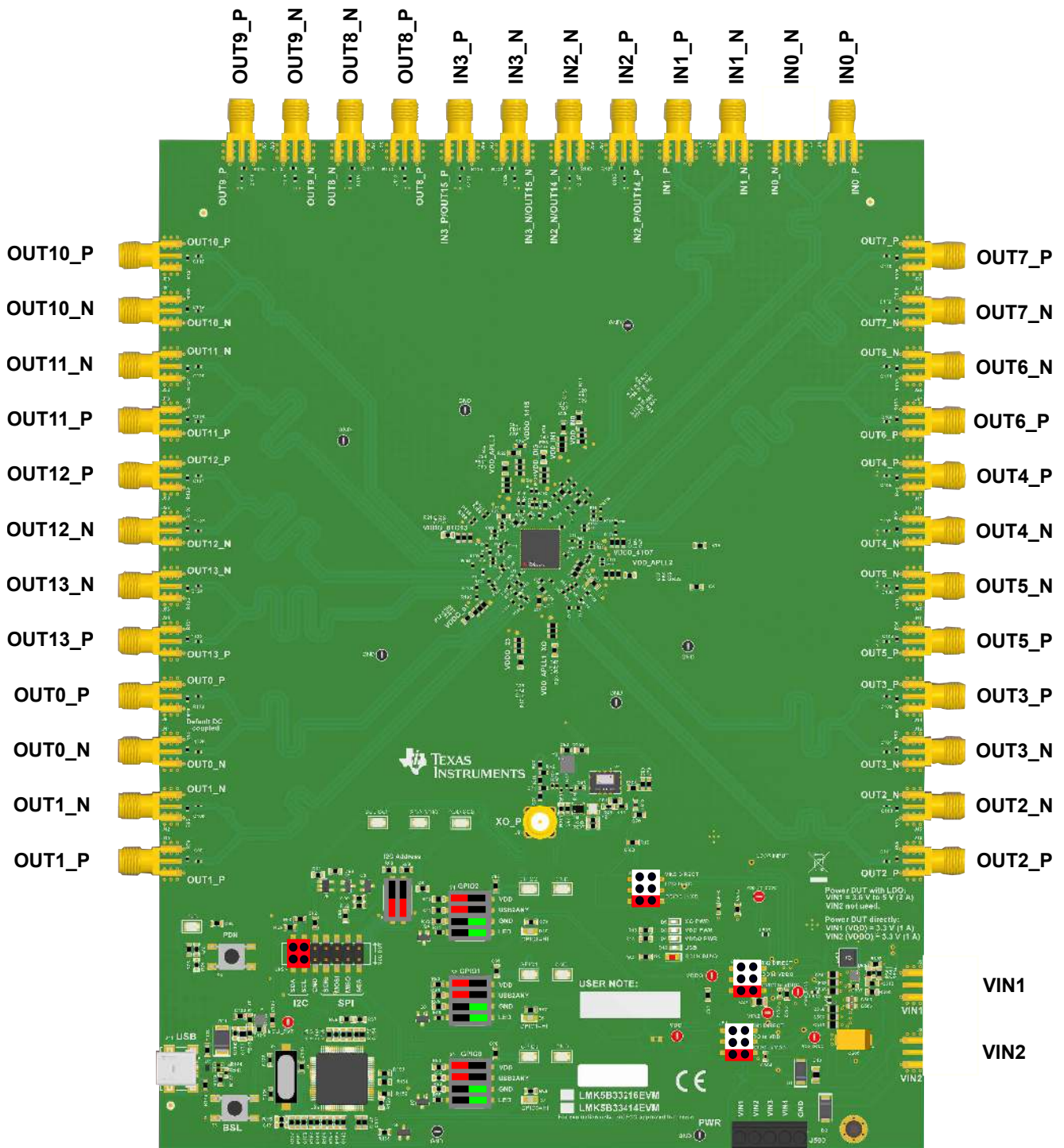

Figure 1-1. LMK5B33414EVM Default Setting of Jumpers and DIP Switches

2 EVM Quick Start

Table 2-1 describes the default jumper positions for the EVM to power the device from a single 12-V supply provided to VIN4. In positional information about jumpers, "opposite designator" means the jumper is placed opposite of the silkscreen designator.

Table 2-1. Default Jumper and DIP Switch Settings

CATEGORY	REFERENCE DESIGNATOR	POSITION	DESCRIPTION
Power	JP1	1-2 (opposite designator)	LMK5B33414 VDD = 3.3 V from DCDC1 provided by U500 on top of the PCB.
	JP2	1-2 (opposite designator)	LMK5B33414 VDDO = 3.3 V from DCDC1 provided by U500 on top of the PCB.
	JP4	1-2 (opposite designator)	XO VCC = 3.3 V DCDC1 provided by U500 on top of PCB.
Communication	JP5	1-2, 3-4	Connect I ² C from onboard USB2ANY to LMK5B33414
LMK5B33414 Control Pins	S3	S3[1:2] = OFF	SCS_ADD = no pullup or pulldown.
	S1, S2, S4	Sx[1,2] = OFF Sx[3,4] = ON	Enable 3.9 kΩ pulldown on GPIO0, GPIO1, and GPIO2

To begin using the LMK5B33414, follow the steps below.

Hardware Setup

1. Verify the EVM default jumper and DIP switch settings shown in [Figure 1-1](#).
2. Connect the 12-V external power DC power supply (1-A limit) to:
 - a. VIN4 and GND terminals on header J500 (pins 4 and 5, see [Figure 3-2](#).)
3. Connect references:
 - a. 25-MHz reference clock to IN0_P/N and/or,
 - b. 25-MHz reference clock to IN1_P/N
4. Connect the USB cable to the USB port at J41.

Software Setup

1. If not already installed, install the TICS Pro software from the TI website: [TICS Pro Software](#)
2. If the MATLAB R2015b (9.0)* 64-bit Runtime is not already installed, download and install the software from the MathWorks website. While optional for programming and evaluating the default profile settings, Matlab Runtime is necessary for any application that needs to modify the DPLL loop filter settings. See [Matlab Runtime](#).
3. Start the TICS Pro software.
4. Select the LMK5B33414 profile from *Select Device* → *Network Synchronizer Clock (Digital PLLs)* → *LMK5B33414*.
5. Confirm communications with the board by:
 - a. Click *USB communications* from the menu bar.
 - b. Click *Interface* to launch the *Communication Setup* pop-up window.
 - c. Check these fields in the *Communication Setup* pop-up window:
 - i. Ensure USB2ANY is selected as the interface.
 - ii. In case of multiple USB2ANY, select desired interface. If a USB2ANY is currently in use in another TICS Pro, you must release that interface by changing its interface setting to *DemoMode*.
 - iii. Click *Identify* to trigger the LED shown in the image below. A blinking LED confirms you are connected to the board you expect. Be aware that USB2ANY devices connected to the PC but not attached to by a TICS Pro instance may blink at a slow rate of 1 second on, 1 second off,

continuously. After clicking the *Identify* button, the LED will flash quickly at about 0.5 seconds on, 0.5 seconds off, for about 5 seconds.

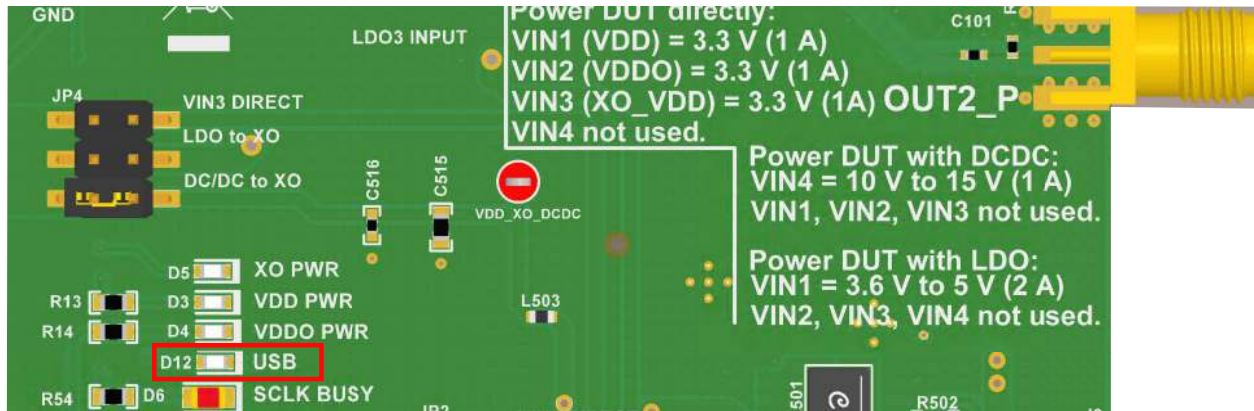

Figure 2-1. USB LED

Program the LMK5B33414

1. Toggle the switch S5 (PDN/RESET).
2. Program all the registers:
 - a. Press the *Write All Regs* button in the toolbar.
 - b. Select *USB Communications* in the menu bar, then select *Write All Registers*, or press Ctrl + L.
3. Check the current consumption.
4. Check LMK5B33414 Status as shown in Figure 2-2.
 - a. Go to the *Status* page of the GUI.
 - b. Click *Read Status Bits*.
 - c. Make sure to clear the latched bits. To clear latched bits:
 - i. Press the *Clear Latched Bits* button.
 - ii. Select *Read Status Bits*.
 - d. Wait to confirm the change. It may take some time for the DPLL status bits to reflect lock.

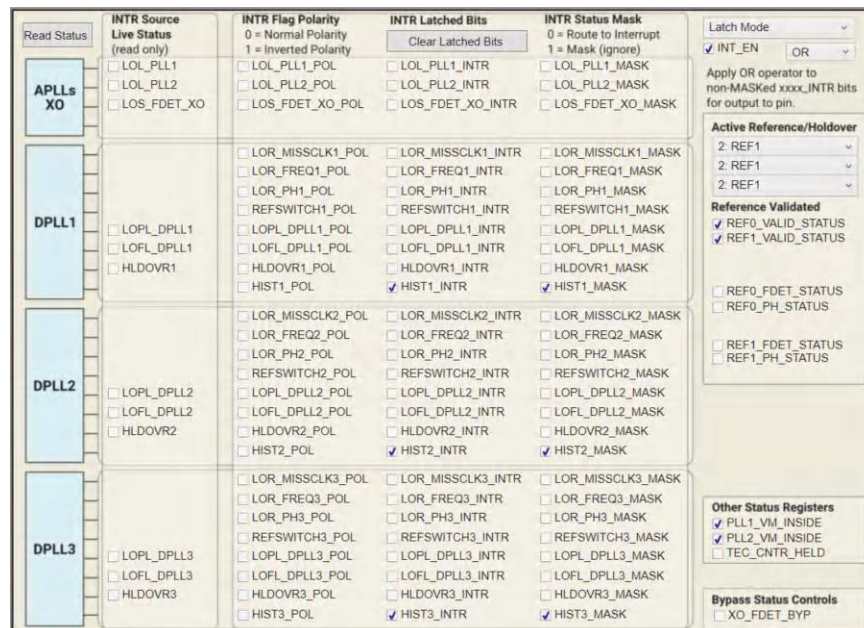

Figure 2-2. Read Status Bits

Measure

Measurements can now be made at the clock outputs.

3 EVM Configuration

The LMK5B33414 is a highly-configurable clock chip with multiple power domains, PLL domains, and clock input and output domains. To support a wide range of LMK5B33414 use cases, the EVM was designed with more flexibility and functionality than needed to implement the chip in a customer system application.

This section describes the power, logic, and clock input and output interfaces on the EVM, as well as how to connect, set up, and operate the EVM. Refer to [Figure 4-1](#).

Table 3-1. Key Components Reference Designators and Descriptions

ITEM NO.	REFERENCE DESIGNATORS	DESCRIPTION
1	U1	LMK5B33414
2	J500 (VIN4 terminal block header)	External Supply, +12 V using default configuration.
3	A	Y1 Onboard TCXO. Y1 will provide improved holdover stability and allow narrower DPLL loop bandwidths to be used in comparison to the external XO input.
	B	J8 SMA connector for external XO. To use the external XO, remove the jumper from JP4 to power down the on-board TCXO.
4	J4/5, J6/7, J37/J39, J40/J38	SMA Ports for Clock Inputs (IN0_P/N, IN1_P/N, IN2_P/N, and IN3_P/N). IN0_N is not populated and IN0_P is configured for single ended input. IN1 is configured for a DC-coupled differential input. IN2 and IN3 are configured for an AC-coupled differential input.
5	J9/11, J10/12, J13/15, J14/16, J17/19, J18/20, J21/J23, J22/24, J25/27, J26/28, J29/31, J30/32, J33/35, J34/36	SMA Ports for Clock Outputs
6	S5	Normally open. Push button for device power down (PD# pin). R76 enables control of the PD# pin through the GUI. If GUI has PD# unchecked on User Controls page under PINS section, the device will be held in power-down condition no matter state of S5. R76 is installed by default.
7	JP5	Jumper header for I ² C/SPI interface (MCU to LMK5B33414)
8	D6	SCL or SCK busy indication LED.
9	J41	USB Port for MCU

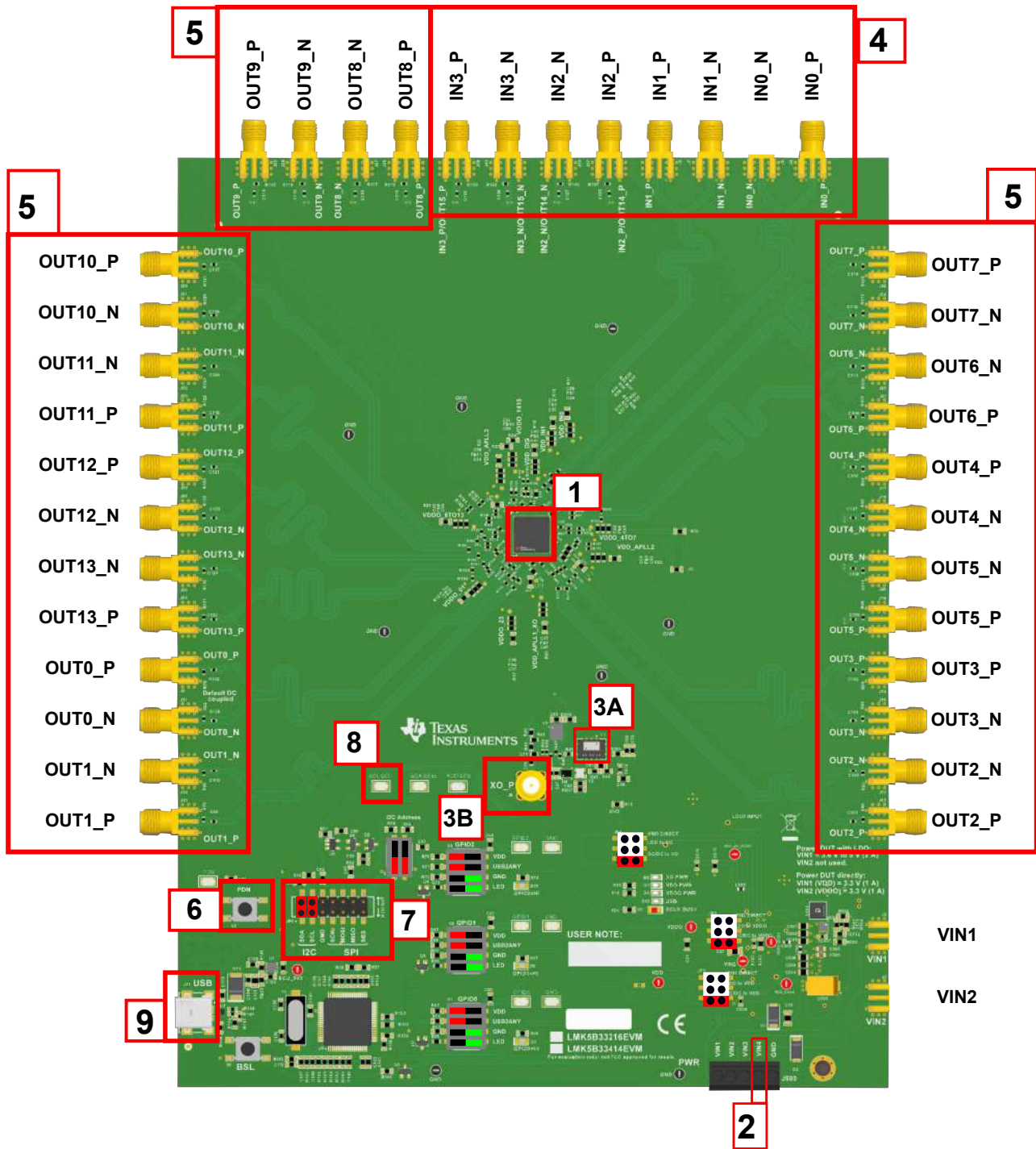

Figure 3-1. Key Components - EVM Top Side

3.1 Power Supply

The LMK5B33414 has VDD and VDDO supply pins that operate from $3.3\text{ V} \pm 5\%$.

J500 is the main power terminal to the external power supply. Power SMA port VIN1 (J2) provides an alternative connector style to apply power through coax cable. By default this SMA connector is not populated.

On the EVM, there are three methods for supplying power.

1. The default power configuration uses the onboard DC/DC supply (U500) to power all VDD and VDDO pins as well as the onboard XO from an external 12-V supply input to VIN4 on J500.
2. The LDO power configuration uses three separate LDO regulators (U9, U10, and U11) to power the VDD, VDDO, and XO from an external 5-V supply input to VIN1 on J500 (or J2).
3. The direct power configuration allows for separate voltage supplies for the VDD, VDDO, and XO. In the direct power configuration mode, an external 3.3-V supply is provided to VIN1 to power the VDD pins, an external 3.3-V supply is provided to VIN2 to power the VDDO pins, and an external 3.3-V supply is provided to VIN3 to power the onboard XO.

Note

Not every power connection is used or required to operate the EVM. Other power configurations are possible. See the power schematics in [Figure 4-1](#) and [Figure 4-3](#).

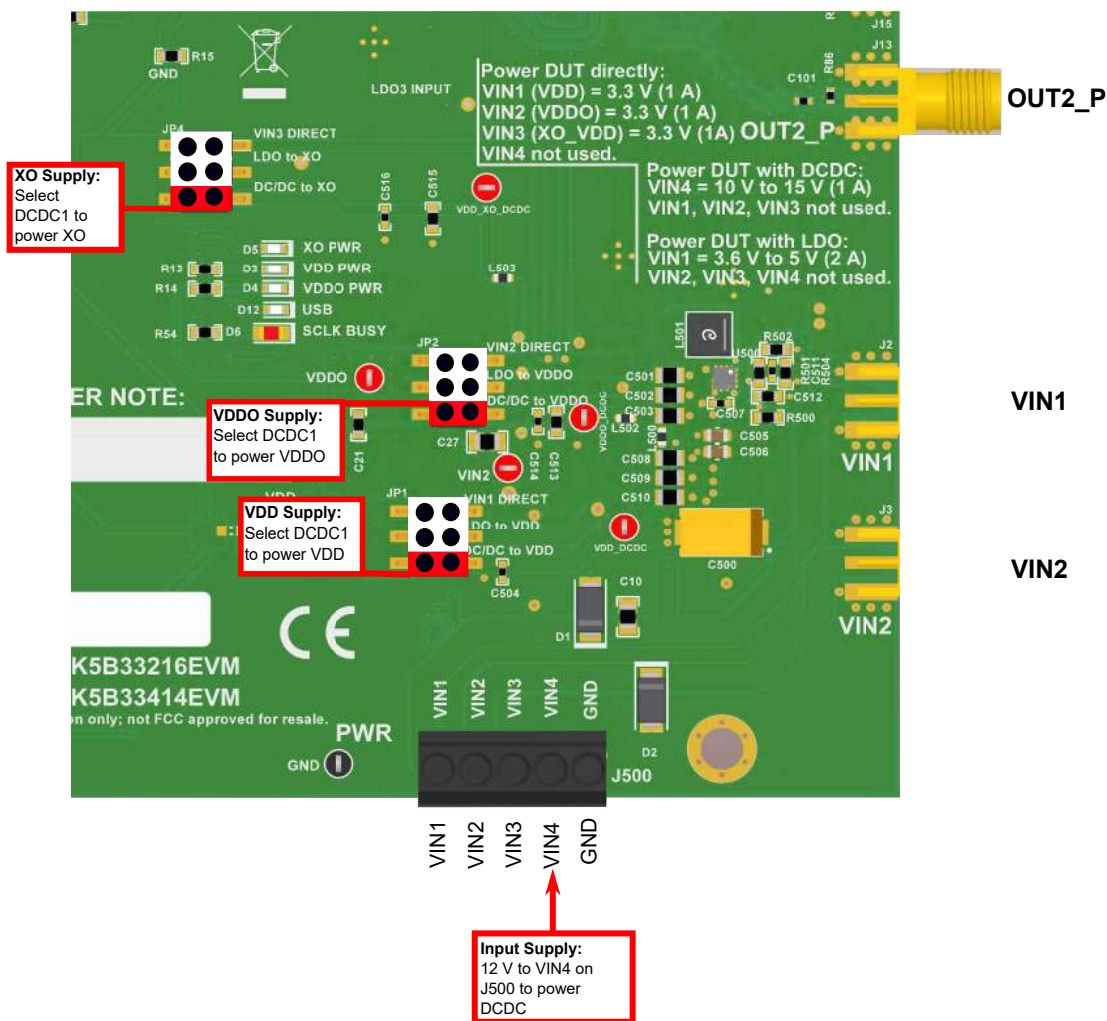

Figure 3-2. Default Power Jumper Configuration

Figure 3-2 shows the default power jumper locations and settings. [Table 3-2](#) shows the suggested power configurations for the LMK5B33414.

Table 3-2. Suggested Power Configurations

CONNECTION	NAME	ONBOARD DC/DC SUPPLY (DEFAULT)	ONBOARD LDO REGULATORS	DIRECT EXTERNAL SUPPLIES
		VDD = 3.3 V (DCDC1) VDDO = 3.3 V (DCDC1) XO = 3.3 V (DCDC1)	VDD = 3.3 V (LDO1) VDDO = 3.3 V (LDO2) XO = 3.3 V (LDO3)	VDD = 3.3 V (EXT. VIN1) VDDO = 3.3 V (EXT. VIN2) XO = 3.3 V (EXT. VIN3)
J500	PWR	<ul style="list-style-type: none"> Pin 1 (VIN1): n/a Pin 2 (VIN2): n/a Pin 3 (VIN3): n/a Pin 4 (VIN4): Connect to external 12-V supply Pin 5 (GND): Connect to supply ground 	<ul style="list-style-type: none"> Pin 1 (VIN1): Connect to external 5-V supply Pin 2 (VIN2): n/a Pin 3 (VIN3): n/a Pin 4 (VIN4): n/a Pin 5 (GND): Connect to supply ground 	<ul style="list-style-type: none"> Pin 1 (VIN1): Connect to external 3.3-V supply Pin 2 (VIN2): Connect to external 3.3-V supply Pin 3 (VIN3): Connect to external 3.3-V supply Pin 4 (VIN4): n/a Pin 5 (GND): Connect to supply ground
JP1	VDD	<ul style="list-style-type: none"> Tie pins 1-2 (opposite to designator) to select 3.3 V from DCDC1 to VDD Plane 	<ul style="list-style-type: none"> Tie pins 3-4 (middle pins) to select 3.3 V from LDO1 to VDD Plane 	<ul style="list-style-type: none"> Tie pins 5-6 (adjacent to designator) to select external VIN1 to VDD Plane
JP2	VDDO	<ul style="list-style-type: none"> Tie pins 1-2 (opposite to designator) to select 3.3 V from DCDC1 to VDD Plane 	<ul style="list-style-type: none"> Tie pins 3-4 (middle pins) to select 3.3 V from LDO2 to VDDO Plane 	<ul style="list-style-type: none"> Tie pins 5-6 (adjacent to designator) to select external VIN2 to VDDO Plane
JP3	XO	<ul style="list-style-type: none"> Tie pins 1-2 (opposite to designator) to select 3.3V from DCDC1 to XO supply 	<ul style="list-style-type: none"> Tie pins 3-4 (middle pins) to select 3.3 V from LDO3 to XO supply 	<ul style="list-style-type: none"> Tie pins 5-6 (adjacent to designator) to select external VIN3 to XO supply

3.2 Logic Inputs and Outputs

The logic I/O pins of the LMK5B33414 support different functions depending on the device start-up mode chosen by the GPIO1 input level upon power on reset (POR).

The default logic input pin states are determined by onboard pullup or pulldown resistors, but some input pins can be driven to high or low state by the MCU output or DIP switch control. The MCU can be controlled from a PC running TICS Pro software to program the device registers through I2C or SPI and also drive the LMK5B33414 logic inputs. To allow the MCU to control the pin input, SW[2] of the DIP switch correlating with the controlled GPIO must be set to on.

See [Table 3-3](#) for the logic pin mapping tables for the device start-up modes.

Table 3-3. Device Start-Up Modes

GPIO1 INPUT LEVEL ⁽¹⁾	START-UP MODE
Low	I ² C Mode
High	SPI Mode

(1) The input levels on these pins are sampled only during POR.

3.3 Switching Between I2C and SPI

To switch the EVM between I2C and SPI modes, the switches and jumpers must be configured as follows:

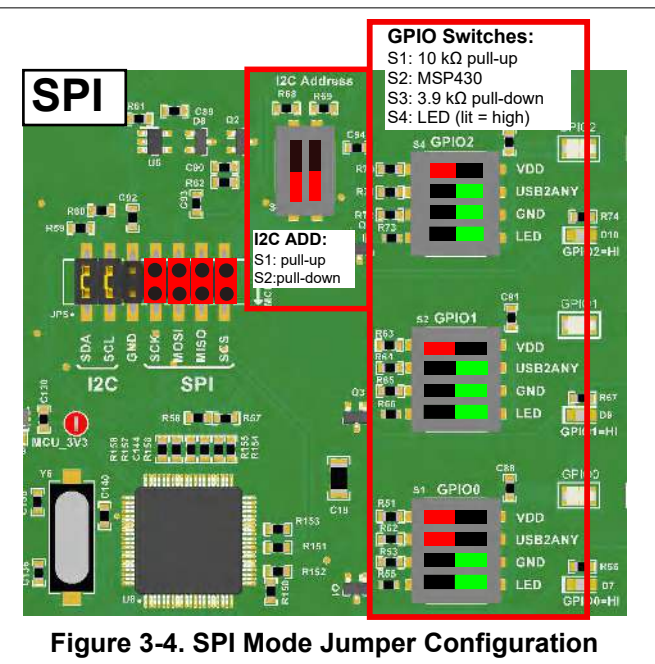
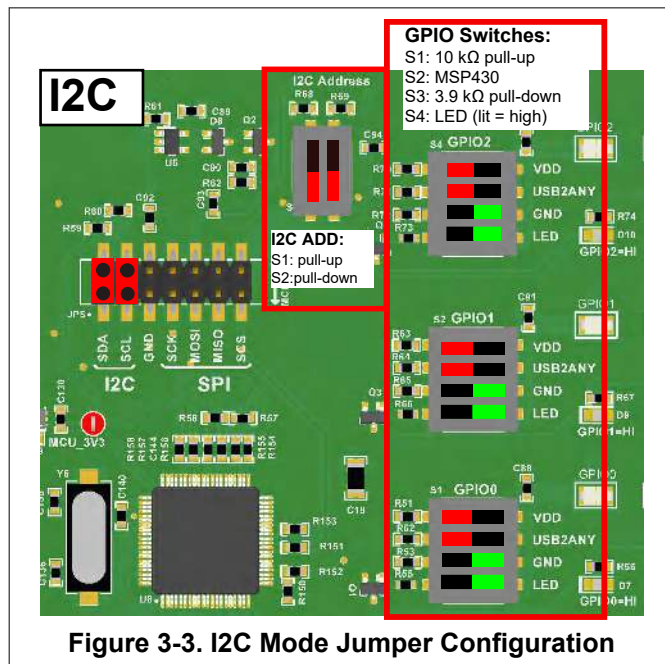

In SPI mode, based on EVM layout routing GPIO2 to SPI host input, GPIO2 must also be configured as *STATUS* or *INT*, *SPI Readback Data (SDO)*, *Active High*, and *CMOS* to support SPI readback.

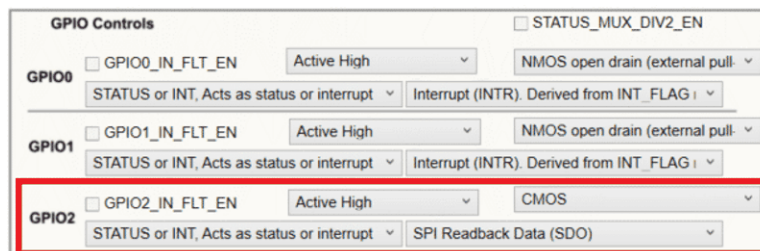

Communication protocols must be set in TICS Pro. From the menu bar, select *USB communications* → *Interface* to get the Communication Setup window and change the protocol.

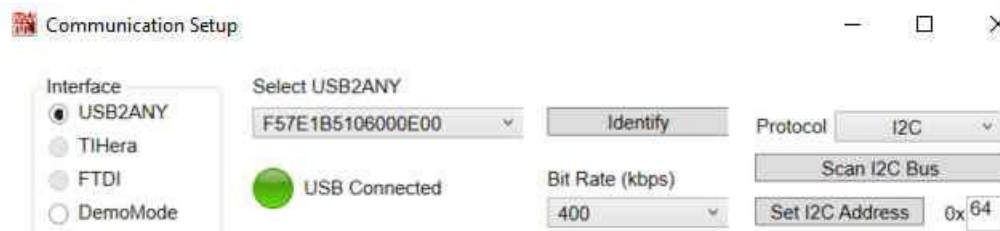

3.4 Generating SYSREF Request

Standard SPI/I2C programming, GPIO0, or GPIO1 can be used to generate a SYSREF request. The TICS Pro software and EVM is designed to use GPIO2 for SPI readback (SDO). Accordingly, GPIO2 is not listed in the pins as it is dedicated for SPI readback. In a user application, any GPIO pin may be used.

Connect the desired GPIO pin to the MCU by setting S2 as ON on the switch block for the desired GPIO. Then, make sure the GPIO pin is configured for *SYSREF_REQ* on the GPIO tab of the GUI. A SYSREF Request can now be issued by toggling the GPIO buttons in the *Pins* section of the *User Controls* tab.

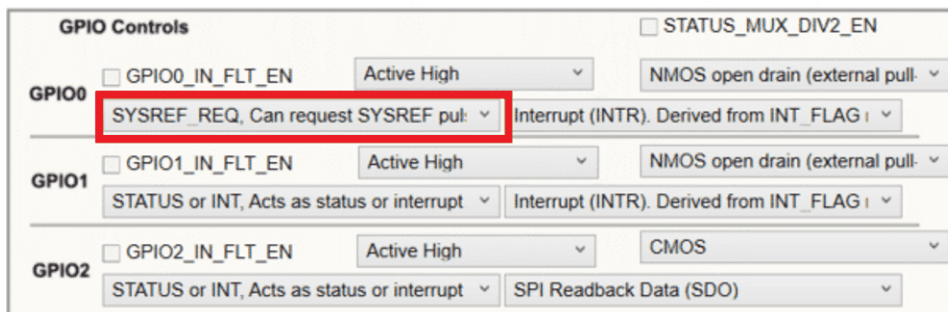

Figure 3-7. GPIO Setting for SYSREF Request



Figure 3-8. GPIO Pin Selection for SYSREF

3.5 XO Input

The LMK5B33414 has an XO input (XO pin) to accept a reference clock for the Fractional-N APLLs. The XO input determines the output frequency accuracy and stability in free-run or holdover modes. For synchronization applications like SyncE or IEEE 1588, the XO input would typically be driven by a low-frequency TCXO or OCXO that conforms to the frequency accuracy and holdover stability requirements of the application. For proper DPLL operation, the XO frequency must have a non-integer frequency relationship with the VCO output frequency of any APLL that uses the XO input as its reference. The non-integer relationship should be greater than 0.05 away from an integer boundary (meaning > 0.05 and < 0.95). When configuring the LMK5B33414 as a clock generator (DPLL not used), then the XO frequency can have an integer relationship with the APLL output frequency.

The XO input of the LMK5B33414 has programmable on-chip input termination and AC-coupled input biasing options to support any clock interface type.

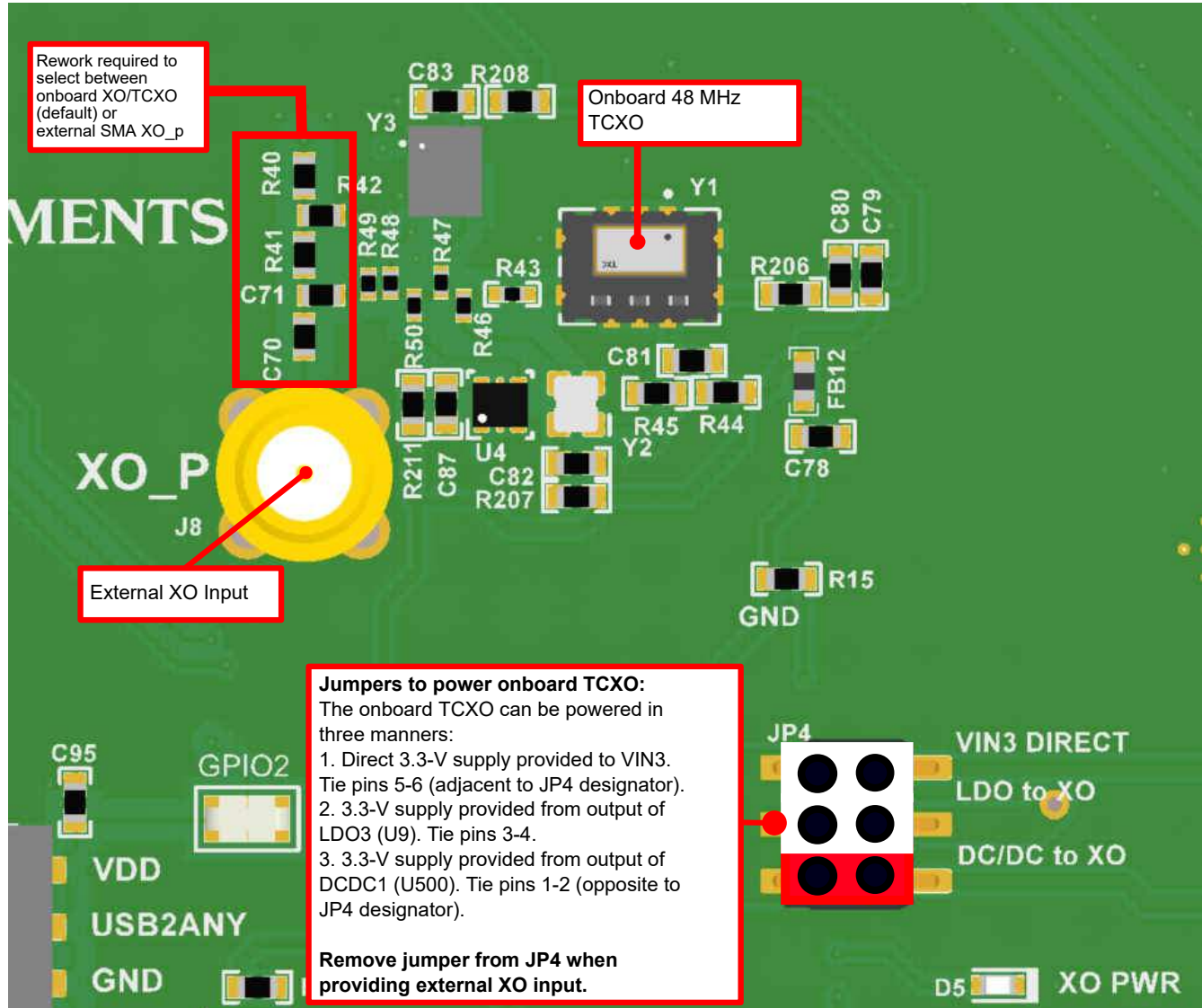

Figure 3-9. XO Input

3.5.1 48-MHz TCXO (Default)

By default, the EVM is populated with a 48-MHz, 3.3-V LVCMOS, low-jitter TCXO, designated as Y1 (3.2 mm × 2.5 mm), which drives the XO input of the LMK5B33414 with the onboard termination and AC coupling. See [Figure 3-9](#). All LMK5B33414 EVMs have a TXC 7N48071001 48-MHz TCXO populated on Y1. Y1 can be used to evaluate various frequency configurations.

3.5.2 External Clock Input

Another option is to feed an external clock to the XO SMA port (J8) to drive the XO input. See [Figure 3-9](#). This path can be connected to the XO input pins. Y1 should be powered down when using the external XO input path. To power down Y1 and use an external XO input, the jumper on JP4 must be removed. Suggested XO frequencies for best device performance are frequencies of 38.88 MHz and 48 MHz. When using an external XO input, TI recommends to remove the capacitor (C71) connecting the TCXO output to the XO input of the LMK5B33414. This will prevent any risk of backdriving the onboard TCXO.

3.5.3 Additional XO Input Options

For flexibility, the EVM provides additional XO input options (use one at a time). C70 allows an external reference to be provided at SMA connector XO (J8). C71 allows one of the onboard XO/TCXO/OCXO footprints to be used.

By default, Y1 is populated with a 48-MHz TCXO and selected with the populated R43 and R206. R43 provides the output clock of Y1 to the XO pin of the LMK5B33414 and R206 provides power to Y1.

Additional PCB footprints are available to install alternate components for performance evaluation of specific oscillators. These additional footprints are Y2 (2.5 × 2.0 mm), Y3 (3.2 mm × 2.5 mm), Y4 (9.7 mm × 7.5 mm), Y5 (25 mm × 22 mm), and U4 (2.5 mm × 2 mm).

When using Y2, Y3, Y4, Y5, or U4, R43 and R206 must be removed to power down and isolate the output of Y1. When populating Y2, R46 and R207 must be populated to power up Y2 and provide its output to the XO pin. When populating Y3, R47 must be populated to provide Y3's output to the XO pin. When populating Y4, R48 must be populated to provide Y4's output to the XO pin. When populating Y5, R49 must be populated to provide Y5's output to the XO pin. When populating U4, R50 must be populated to provide U4's output to the XO pin. [Section 4.8](#) shows the components described above.

Take care if more than one device is installed to remove resistors to power down unused oscillators and isolate their outputs as described above.

3.5.4 APLL Reference Options

The LMK5B33414 APLLs may accept any other APLL output as a reference instead of the XO. The BAW on APLL3 provides a good option for a high-frequency cascaded APLL reference. [Figure 6-2](#) shows how to configure the APLL reference to be cascaded from another APLL.

3.6 Reference Clock Inputs

The LMK5B33414 has four DPLL reference clock input pairs (IN0_P/N, IN1_P/N, IN2_P/N, and IN3_P/N) with configurable input priority and input selection modes. The inputs have programmable input type, termination, and biasing options to support any clock interface type.

External LVCMOS or differential reference clock inputs can be applied to the SMA ports, labeled IN0_P/N, IN1_P/N, IN2_P/N, and IN3_P/N. All SMA inputs are routed through 50-Ω single-ended traces. To accommodate evaluation of different input types, the EVM default assembly supports two AC-coupled differential inputs (IN2_P/N and IN3_P/N), one DC-coupled differential input (IN1_P/N) and one DC-coupled single-ended input (IN0_P). When applying a single-ended signal, connect to the noninverting input (IN0_P, IN1_P, IN2_P, or IN3_P).

3.7 Clock Outputs

The LMK5B33414 has 14 clock output pairs (OUT[0:13]_P/N).

OUT0 is configured as DC-coupled for LVCMOS evaluation purposes. OUT1, OUT2, and OUT3 have 50 Ω to GND followed by an AC-coupling capacitor for HCSL evaluation purposes. OUT4 to OUT13 are AC-coupled to the SMA ports for LVDS and HSDS evaluation purposes.

When changing output type in the programming software, ensure the required board modifications are also implemented for proper operation.

WARNING

DC-coupled clocks should not be directly connected to RF equipment which cannot accept DC voltage greater than 0 V. For example, spectrum analyzers and phase noise analyzers.

3.8 Status Outputs and LEDs

Status outputs signals can be configured on the GPIO0, GPIO1, and GPIO2 pins. The status output types are 3.3-V LVCMOS or NMOS open-drain.

Additional to monitoring devices statuses, GPIO1 and GPIO2 can be used for SYSREF replication. This allows for two additional LVCMOS outputs to be provided from the LMK5B33414. TP33 can be used to measure the GPIO1 output. TP38 can be used to measure the GPIO2 output. [Figure 4-9](#) shows these test points.

3.9 Requirements for Making Measurements

When performing measurements with the LMK5B33414EVM, the following procedures must be completed:

1. Ensure all required outputs have proper termination components installed to match the desired output types. [Figure 3-10](#) shows the recommended output terminations for each output format.

For LVDS and HSDS outputs, the oscilloscope must be set to 50-Ω impedance. For HCSL outputs, the oscilloscope must be set to 1-MΩ impedance.

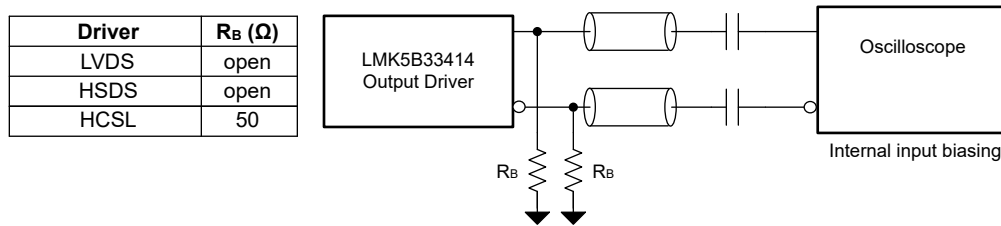

Figure 3-10. Output Termination Recommendations

2. Ensure all enabled outputs that are not connected to any test equipment have a 50-Ω SMA termination. [Figure 3-11](#) shows an example of a 50-Ω SMA termination.



Figure 3-11. 50-Ω SMA Termination

3.10 Typical Phase Noise Characteristics

These plots show the typical phase noise performance for common frequencies outputted from the BAW (VCO3).

The EVM configuration used to obtain these measurements is as follows:

1. XO frequency = 48 MHz (Onboard TCXO)
2. Outputs were configured as HSDS outputs following the methods described in [Section 3.9](#).

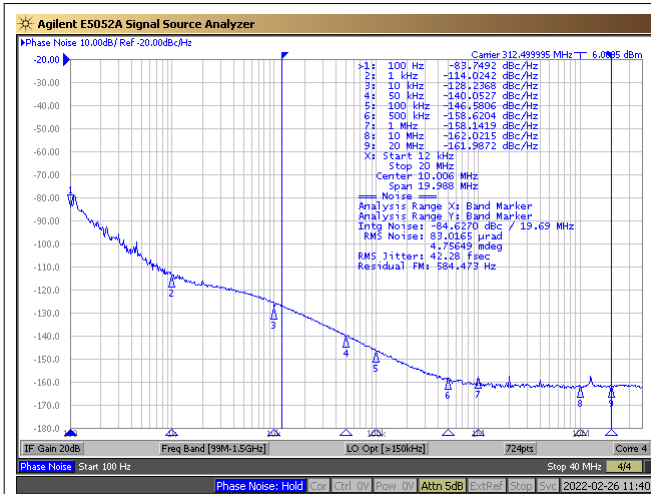

Figure 3-12. APLL3 312.5-MHz Phase Noise Performance

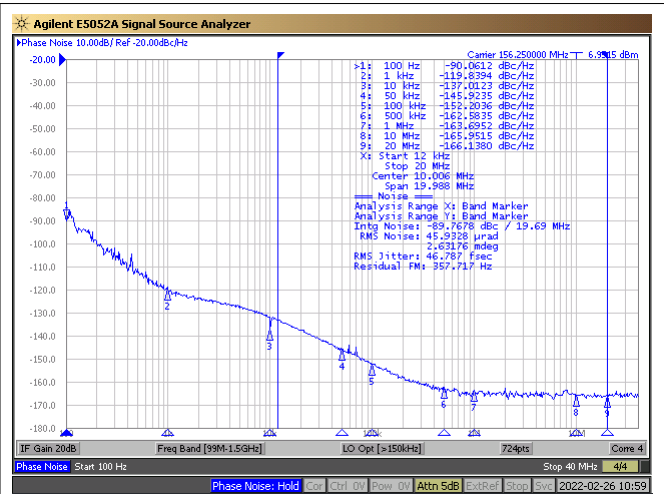

Figure 3-13. APLL3 156.25-MHz Phase Noise Performance

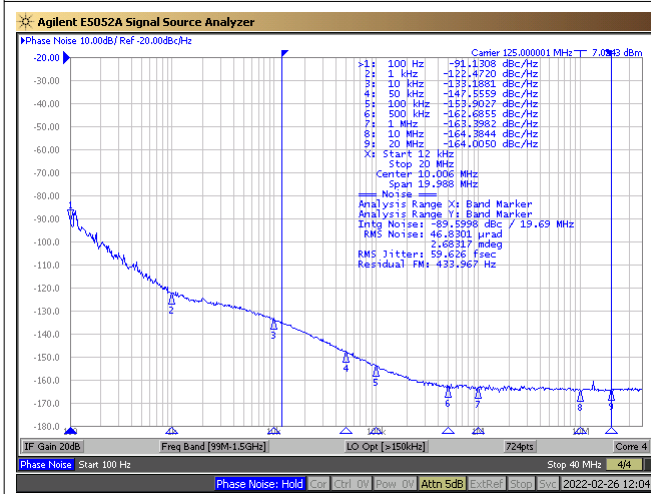

Figure 3-14. APLL3 125-MHz Phase Noise Performance

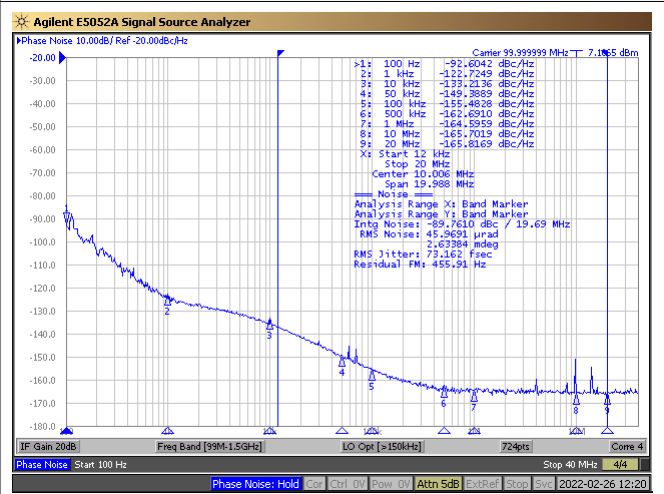

Figure 3-15. APLL3 100-MHz Phase Noise Performance

4 EVM Schematics

4.1 Power Supply Schematic

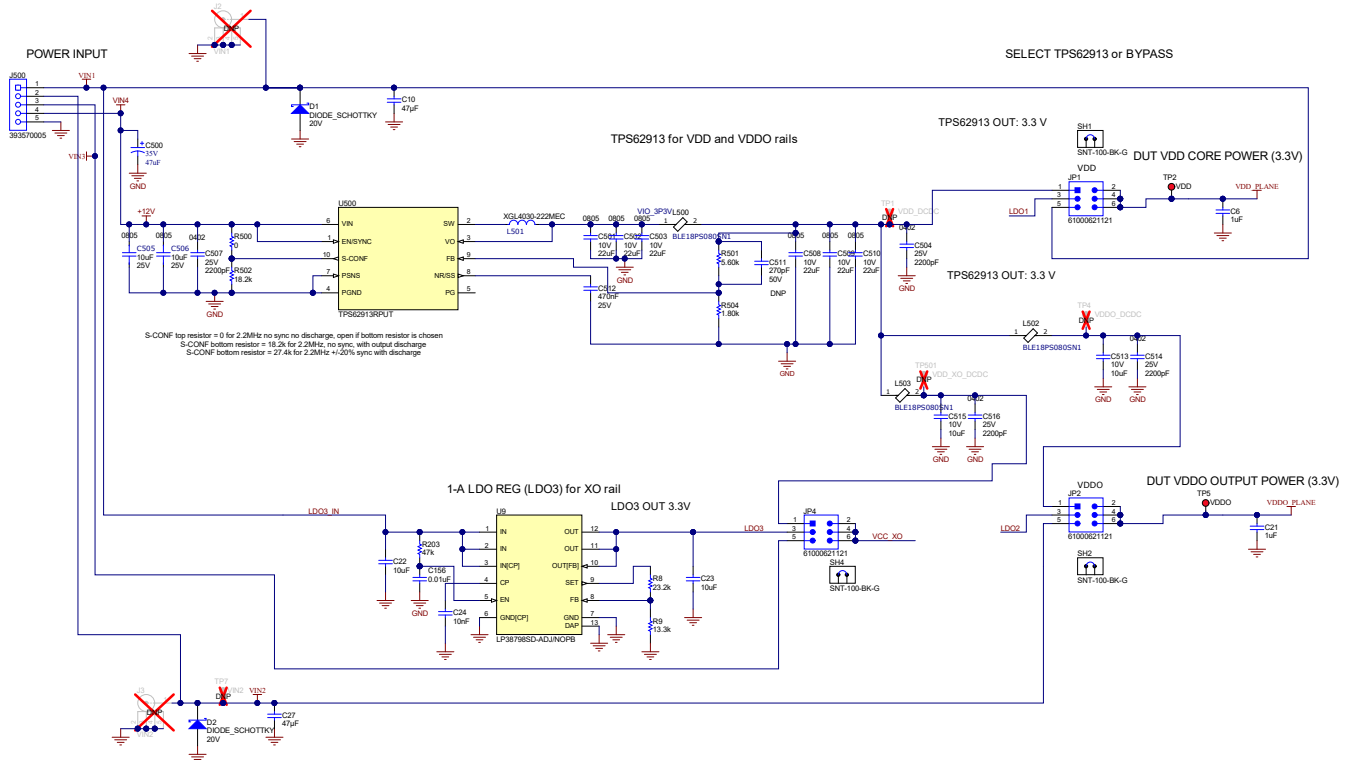

Figure 4-1. Power Supplies

4.2 Alternative Power Supply Schematic

1-A LDO REG (LDO1, LDO2) for DUT VDD & VDDO rails

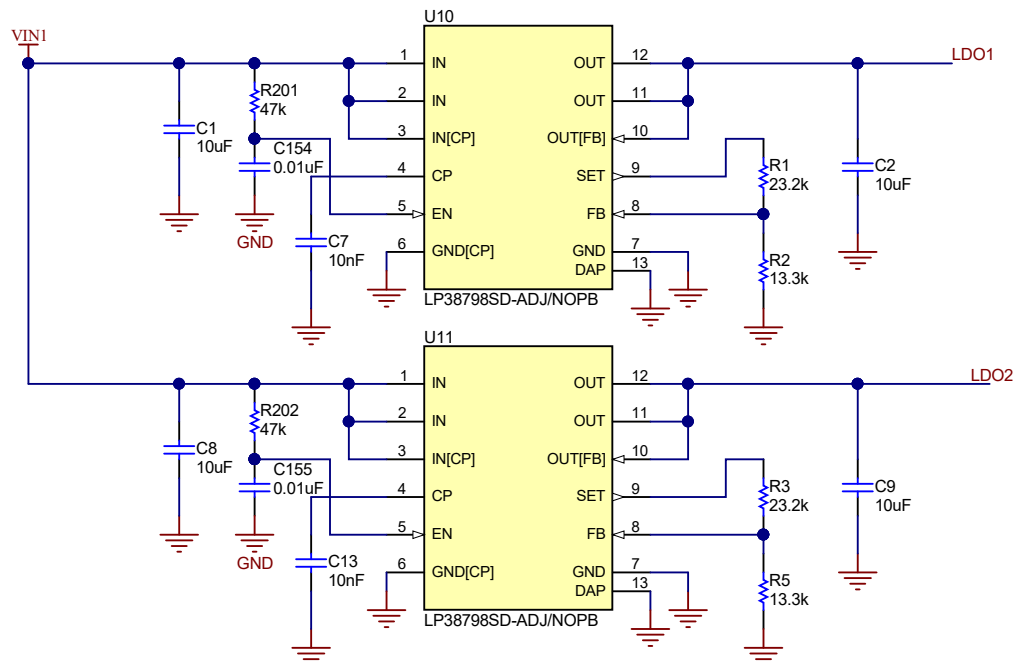

Figure 4-2. Alternative Power Supply

4.3 Power Distribution Schematic

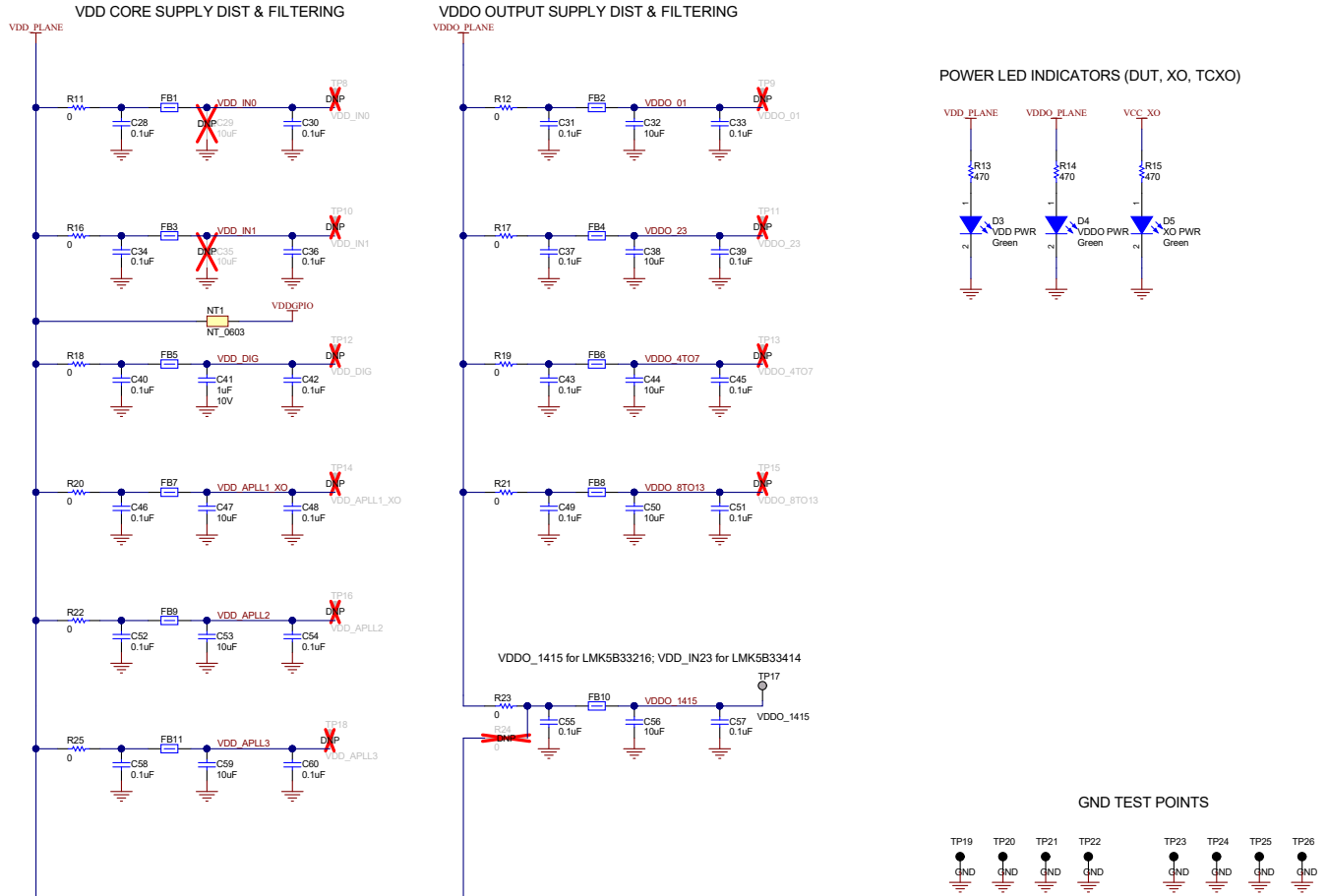

Figure 4-3. Power Distribution

4.4 LMK5B33414 and Input Reference Inputs IN0 to IN1 Schematic

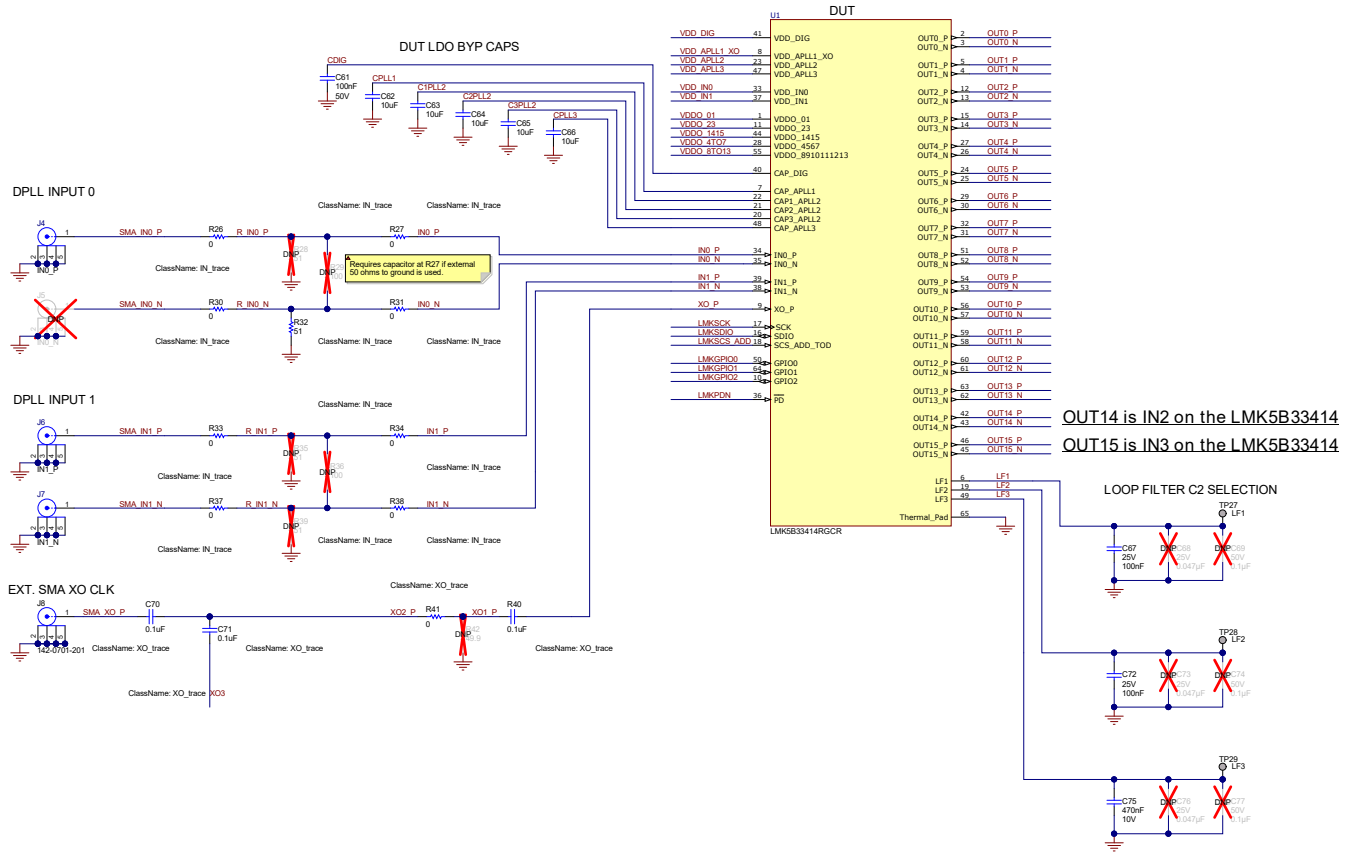

Figure 4-4. LMK5B33414 and Input Reference Inputs IN0 to IN1

4.5 Clock Outputs OUT0 to OUT3 Schematic

OUT0-OUT3 CLOCK OUTPUTS

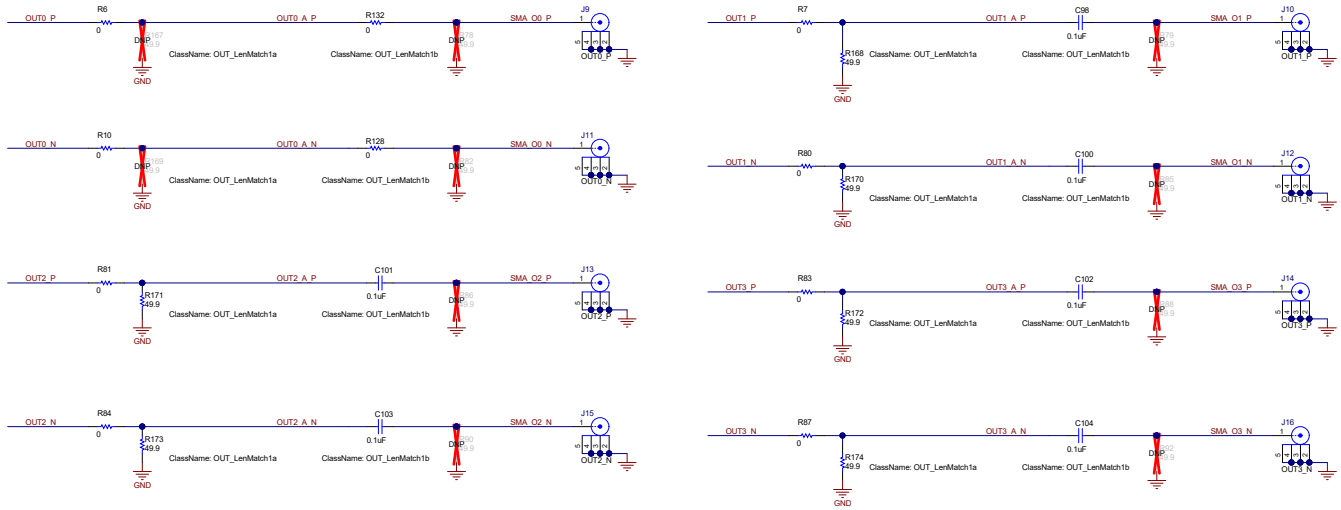

Figure 4-5. Clock Outputs OUT0 to OUT3

4.6 Clock Outputs OUT4 to OUT9 Schematic

OUT4 to OUT9 CLOCK OUTPUTS

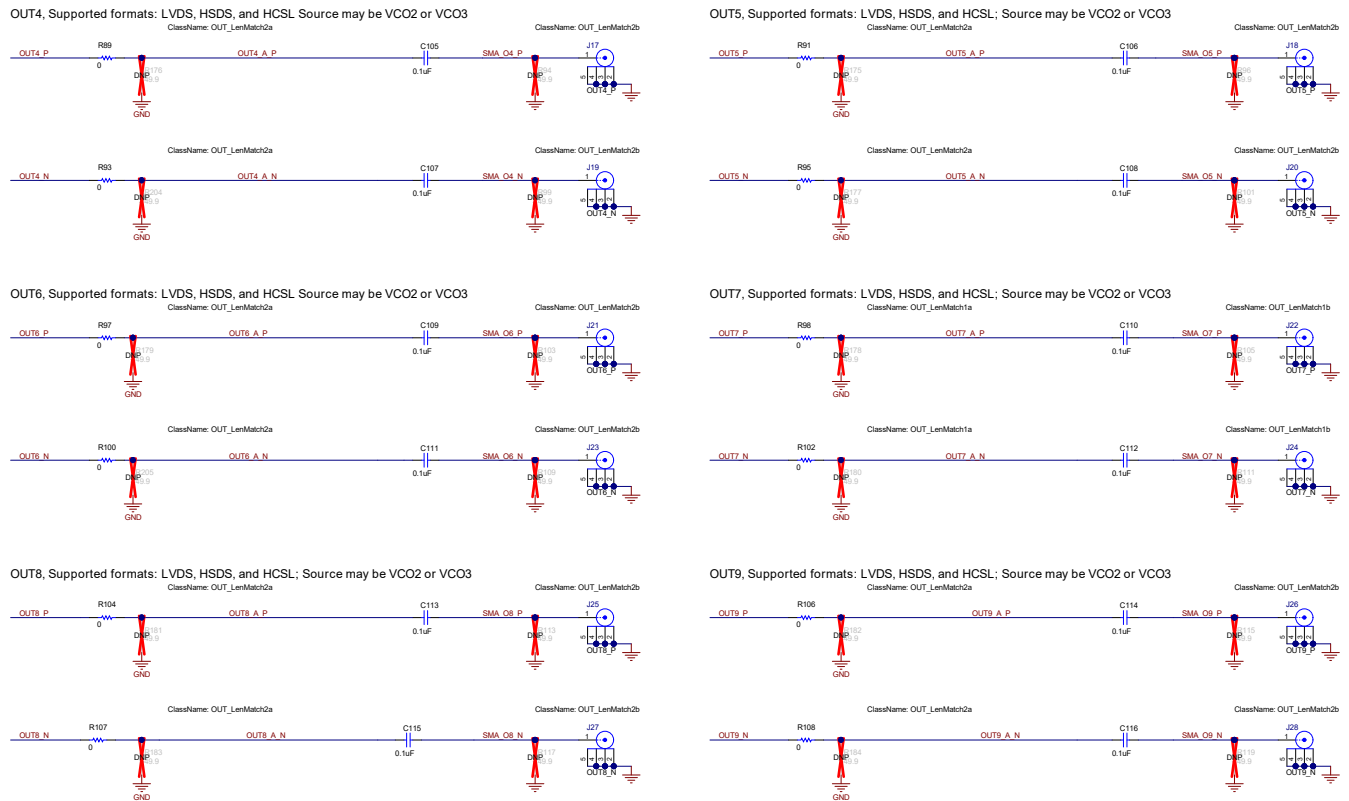

Figure 4-6. Clock Outputs OUT4 to OUT9

4.7 Clock Outputs OUT10 to OUT13 and Clock Inputs IN2 and IN3 Schematic

OUT10-OUT15 CLOCK OUTPUTS

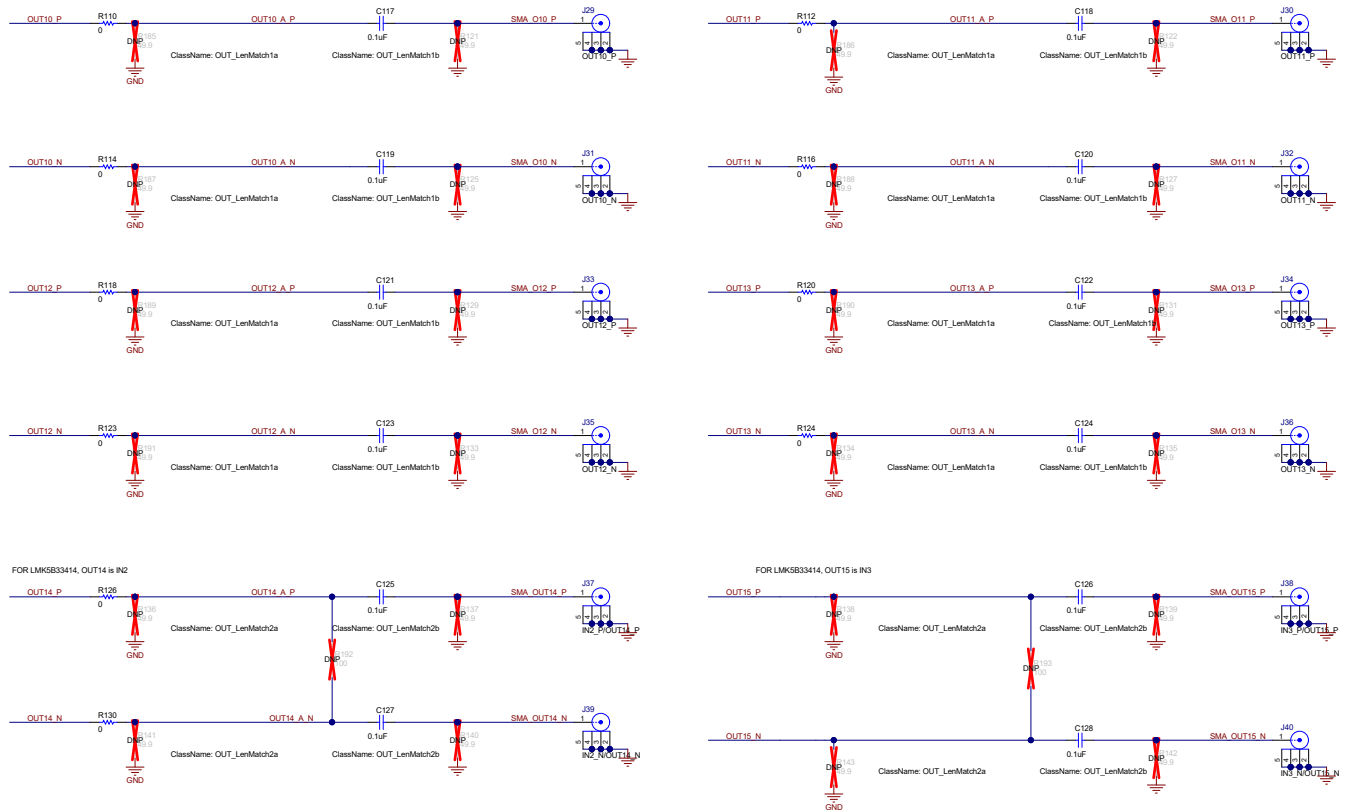

Figure 4-7. Clock Outputs OUT10 to OUT13 and Clock Inputs IN2 and IN3

4.8 XO Schematic

3.3V LVCMOS XO (multiple footprints)

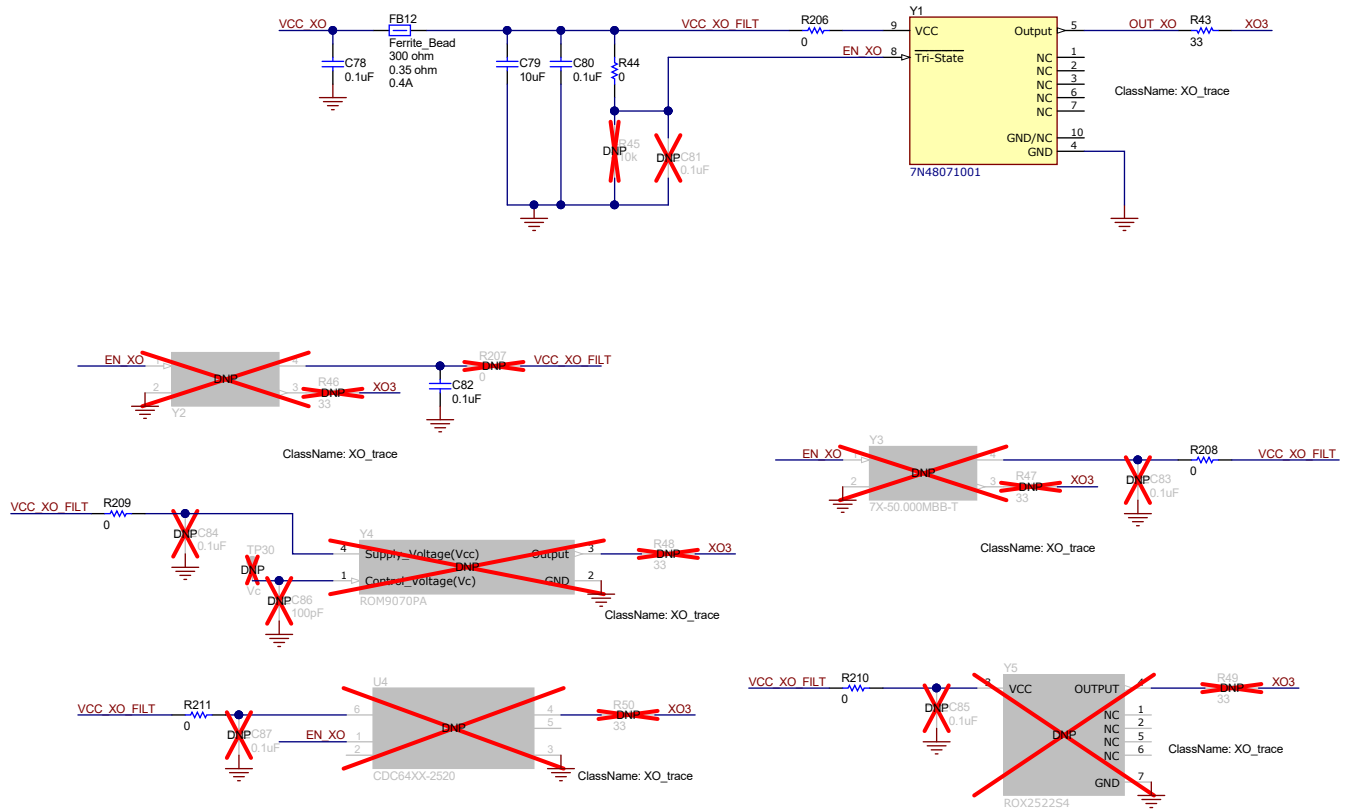

Figure 4-8. XO

4.9 Logic I/O Interfaces Schematic

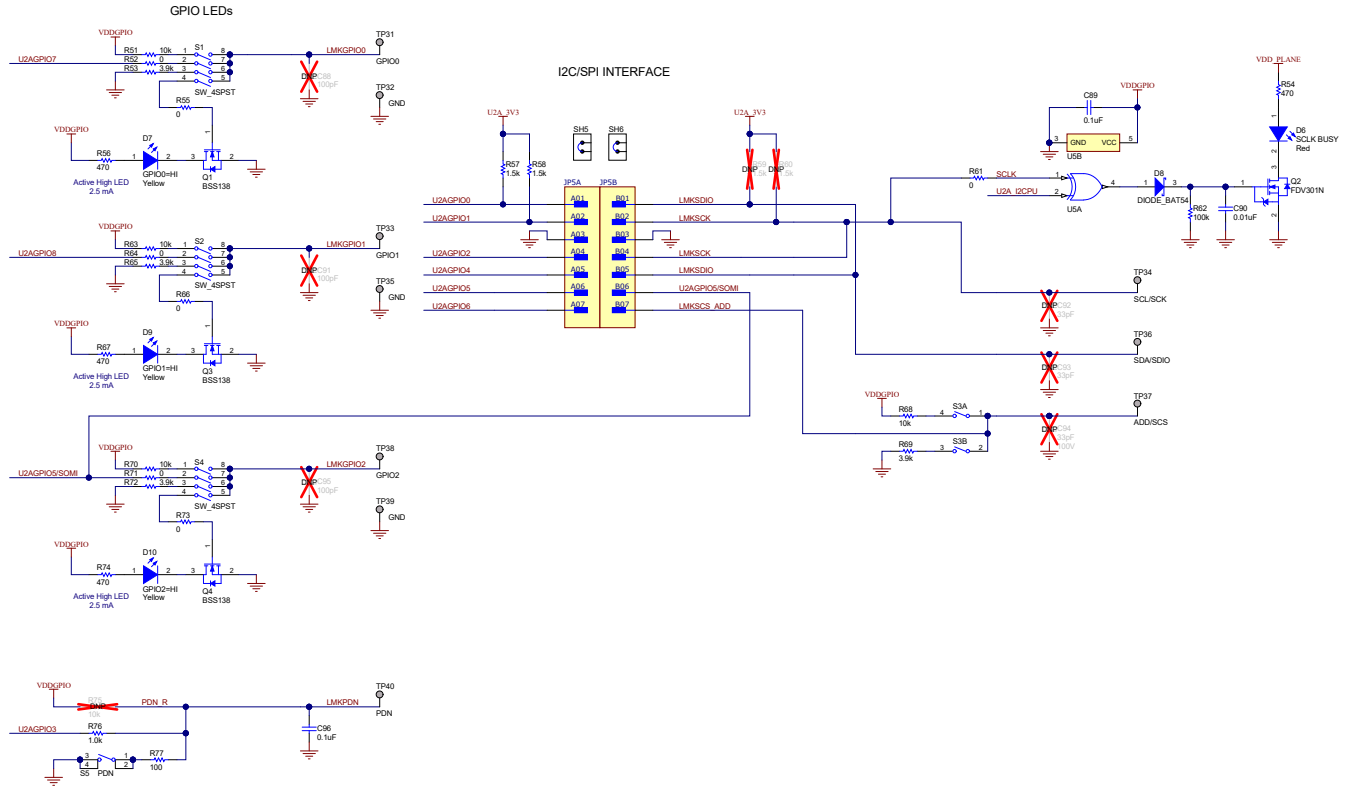

Figure 4-9. Logic I/O Interfaces

5 EVM Bill of Materials

Table 5-1. EVM Bill of Materials (BOM)

DESIGNATOR	QTY	VALUE	DESCRIPTION	PARTNUMBER	MANUFACTURER
PCB1	1		Printed Circuit Board	HSDC145	Any
C1, C2, C7, C8, C9, C13, C22, C23, C24, C32, C38, C44, C47, C50, C53, C56, C59, C62, C63, C64, C65, C66, C79, C97, C129, C130	26	10uF	CAP, CERM, 10 uF, 10 V, +/- 20%, X5R, 0603	C1608X5R1A106M080AC	TDK
C6, C21, C41	3	1uF	CAP, CERM, 1 uF, 10 V, +/- 10%, X5R, 0603	C0603C105K8PACTU	Kemet
C10, C27	2	47uF	CAP, CERM, 47 µF, 10 V, +/- 20%, X5R, 0805	GRM21BR61A476ME15L	MuRata
C28, C31, C34, C37, C40, C43, C46, C49, C52, C55, C58, C67, C70, C71, C72, C78, C80, C82, C96, R40	20	0.1uF	CAP, CERM, 0.1 uF, 25 V, +/- 5%, X7R, 0603	C0603C104J3RACTU	Kemet
C30, C33, C36, C39, C42, C45, C48, C51, C54, C57, C60	11	0.1uF	CAP, CERM, 0.1 uF, 10 V, +/- 10%, X5R, 0402	C1005X5R1A104K050BA	TDK
C61	1	0.1uF	CAP, CERM, 0.1 uF, 50 V, +/- 10%, X7R, 0603	C1608X7R1H104K080AA	TDK
C75, C141	2	0.47uF	CAP, CERM, 0.47 uF, 10 V, +/- 10%, X7R, 0603	GRM188R71A474KA61D	MuRata
C89, C132, C133, C137, C138, C142, C143, C144	8	0.1uF	CAP, CERM, 0.1 uF, 16 V, +/- 5%, X7R, 0603	C0603C104J4RACTU	Kemet
C90, C154, C155, C156	4	0.01uF	CAP, CERM, 0.01 uF, 50 V, +/- 5%, X7R, 0603	C0603C103J5RACTU	Kemet
C98, C100, C101, C102, C103, C104, C105, C106, C107, C108, C109, C110, C111, C112, C113, C114, C115, C116, C117, C118, C119, C120, C121, C122, C123, C124, C125, C126, C127, C128	30	0.1uF	CAP, CERM, 0.1 uF, 25 V, +/- 10%, X7R, 0402	GRM155R71E104KE14D	MuRata
C131	1	22uF	CAP, CERM, 22 uF, 10 V, +/- 20%, X5R, 0805	LMK212BJ226MG-T	Taiyo Yuden
C134, C140	2	220pF	CAP, CERM, 220 pF, 50 V, +/- 1%, C0G/NP0, 0603	06035A221FAT2A	AVX
C135, C136	2	30pF	CAP, CERM, 30 pF, 100 V, +/- 5%, C0G/NP0, 0603	GRM1885C2A300JA01D	MuRata
C139	1	2200pF	CAP, CERM, 2200 pF, 50 V, +/- 10%, X7R, 0603	C0603C222K5RACTU	Kemet

Table 5-1. EVM Bill of Materials (BOM) (continued)

DESIGNATOR	QTY	VALUE	DESCRIPTION	PARTNUMBER	MANUFACTURER
C500	1	47uF	CAP, TA, 47 uF, 35 V, +/- 10%, 0.3 ohm, SMD	T495X476K035ATE300	Kemet
C501, C502, C503, C508, C509, C510	6	22uF	CAP, CERM, 22 uF, 10 V, +/- 20%, X7S, 0805	C2012X7S1A226M125AC	TDK
C504, C507, C514, C516	4	2200pF	CAP, CERM, 2200 pF, 25 V, +/- 10%, X7R, 0402	GRM155R71E222KA01D	MuRata
C505, C506	2		10µF ±10% 25V Ceramic Capacitor X7S 0805 (2012 Metric)	C2012X7S1E106K125AC	TDK
C511	1		CAP CER 270PF 50V NP0 0402	UMK105CG271JV-F	Taiyo Yuden
C512	1	0.47uF	CAP, CERM, 0.47 µF, 25 V,+/- 10%, X7R, 0603	C1608X7R1E474K080AE	TDK
C513, C515	2	10uF	CAP, CERM, 10 uF, 10 V, +/- 20%, X7R, 0603	GRM188Z71A106MA73D	MuRata
D1, D2	2	20V	Diode, Schottky, 20 V, 2 A, SMA	B220A-13-F	Diodes Inc.
D3, D4, D5, D12	4	Green	LED, Green, SMD	LTST-C190GKT	Lite-On
D6	1	Red	LED, Red, SMD	LTST-C170KRKT	Lite-On
D7, D9, D10	3	Yellow	LED, Yellow , SMD	LTST-C170KSKT	Lite-On
D8	1	30V	Diode, Schottky, 30 V, 0.2 A, SOT-23	BAT54-7-F	Diodes Inc.
FB1, FB2, FB3, FB4, FB5, FB6, FB7, FB8, FB9, FB10, FB11	11	220 ohm	Ferrite Bead, 220 ohm @ 100 MHz, 2.5 A, 0603	BLM18SG221TN1D	MuRata
FB12	1	300 ohm	Ferrite Bead, 300 ohm @ 100 MHz, 0.4 A, 1.6x0.8x0.95mm	LI0603D301R-10	Laird-Signal Integrity Products
FB13	1	60 ohm	Ferrite Bead, 60 ohm @ 100 MHz, 3.5 A, 0603	MPZ1608S600ATAH0	TDK
FID1, FID2, FID3, FID4, FID5, FID6	6		Fiducial mark. There is nothing to buy or mount.	N/A	N/A
H1, H2, H3, H4, H5, H6	6		BUMPER CYLIN 0.312" DIA	SJ61A6	3M
J4, J6, J7, J9, J10, J11, J12, J13, J14, J15, J16, J17, J18, J19, J20, J21, J22, J23, J24, J25, J26, J27, J28, J29, J30, J31, J32, J33, J34, J35, J36, J37, J38, J39, J40	35		CONN SMA JACK STR EDGE MNT	CON-SMA-EDGE-S	RF Solutions Ltd.
J8	1		Connector, SMA, TH	142-0701-201	Cinch Connectivity
J41	1		Connector, Receptacle, Mini-USB Type B, R/A, Top Mount SMT	1734035-2	TE Connectivity
J42	1		Header, 2.54mm, 15x2, Gold, SMD	HTST-115-01-L-DV	Samtec

Table 5-1. EVM Bill of Materials (BOM) (continued)

DESIGNATOR	QTY	VALUE	DESCRIPTION	PARTNUMBER	MANUFACTURER
J500	1		Terminal Block, 3.5mm, 5x1, Tin, TH	393570005	Molex
JP1, JP2, JP4	3		Header, 2.54mm, 3x2, Gold, SMT	61000621121	Würth Elektronik
JP5	1		Connector Header Surface Mount 14 position 0.100" (2.54mm)	54202-G0807LF	Amphenol ICC
L500, L502, L503	3		Bead inductor BLE series, 8A	BLE18PS080SN1	Murata
L501	1		Inductor Power Shielded Wirewound 2.2uH 20% 1MHz Composite 8.7A 15mOhm DCR Automotive T/R	XGL4030-222MEC	Coilcraft
LBL1	1		Thermal Transfer Printable Labels, 0.650" W x 0.200" H - 10,000 per roll	THT-14-423-10	Brady
Q1, Q3, Q4, Q5	4	50V	MOSFET, N-CH, 50 V, 0.22 A, SOT-23	BSS138	Fairchild Semiconductor
Q2	1	25V	MOSFET, N-CH, 25 V, 0.22 A, SOT-23	FDV301N	Fairchild Semiconductor
R1, R3, R8	3	23.2k	RES, 23.2 k, 1%, 0.1 W, AEC- Q200 Grade 0, 0603	CRCW060323K2FKEA	Vishay-Dale
R2, R5, R9	3	13.3k	RES, 13.3 k, 1%, 0.1 W, AEC- Q200 Grade 0, 0603	CRCW060313K3FKEA	Vishay-Dale
R6, R7, R10, R80, R81, R83, R84, R87, R89, R91, R93, R95, R97, R98, R100, R102, R104, R106, R107, R108, R110, R112, R114, R116, R118, R120, R123, R124, R126, R128, R130, R132	32	0	RES, 0, 5%, 0.063 W, AEC-Q200 Grade 0, 0402	RK73Z1ETTP	KOA Speer
R11, R12, R16, R17, R18, R19, R20, R21, R22, R23, R25, R41, R52, R55, R61, R64, R66, R71, R73, R150, R151, R152, R153, R154, R155, R156, R157, R158, R163, R164, R212	31	0	RES, 0, 5%, 0.1 W, AEC-Q200 Grade 0, 0603	CRCW06030000Z0EA	Vishay-Dale
R13, R14, R15, R54, R56, R67, R74	7	470	RES, 470, 5%, 0.1 W, AEC-Q200 Grade 0, 0603	CRCW0603470RJNEA	Vishay-Dale
R26, R27, R30, R31, R33, R34, R37, R38	8	0	RES, 0, 0%, 0.2 W, AEC-Q200 Grade 0, 0402	CRCW04020000Z0EDHP	Vishay-Dale
R32	1	51	RES, 51, 5%, 0.0625 W, 0402	RC0402JR-0751RL	Yageo America
R43, R144, R146	3	33	RES, 33, 5%, 0.063 W, AEC- Q200 Grade 0, 0402	CRCW040233R0JNED	Vishay-Dale

Table 5-1. EVM Bill of Materials (BOM) (continued)

DESIGNATOR	QTY	VALUE	DESCRIPTION	PARTNUMBER	MANUFACTURER
R44, R500	2	0	RES, 0, 5%, 0.1 W, AEC-Q200 Grade 0, 0603	ERJ-3GEY0R00V	Panasonic
R51, R63, R68, R70	4	10k	RES, 10 k, 5%, 0.1 W, AEC-Q200 Grade 0, 0603	CRCW060310K0JNEA	Vishay-Dale
R53, R65, R69, R72	4	3.9k	RES, 3.9 k, 5%, 0.1 W, AEC-Q200 Grade 0, 0603	CRCW06033K90JNEA	Vishay-Dale
R57, R58	2	1.5k	RES, 1.5 k, 5%, 0.1 W, AEC-Q200 Grade 0, 0603	CRCW06031K50JNEA	Vishay-Dale
R62	1	100k	RES, 100 k, 5%, 0.1 W, AEC-Q200 Grade 0, 0603	CRCW0603100KJNEA	Vishay-Dale
R76, R159, R160	3	1.0k	RES, 1.0 k, 5%, 0.1 W, AEC-Q200 Grade 0, 0603	CRCW06031K00JNEA	Vishay-Dale
R77	1	100	RES, 100, 5%, 0.25 W, AEC-Q200 Grade 0, 0603	ESR03EZPJ101	Rohm
R145, R148, R165	3	33k	RES, 33 k, 5%, 0.1 W, AEC-Q200 Grade 0, 0603	CRCW060333K0JNEA	Vishay-Dale
R147	1	1.5k	RES, 1.5 k, 5%, 0.063 W, AEC-Q200 Grade 0, 0402	CRCW04021K50JNED	Vishay-Dale
R149	1	1.2Meg	RES, 1.2 M, 5%, 0.1 W, AEC-Q200 Grade 0, 0603	CRCW06031M20JNEA	Vishay-Dale
R161, R162, R166	3	510	RES, 510, 5%, 0.1 W, AEC-Q200 Grade 0, 0603	CRCW0603510RJNEA	Vishay-Dale
R168, R170, R171, R172, R173, R174	6	49.9	RES, 49.9, 1%, 0.1 W, AEC-Q200 Grade 0, 0402	ERJ-2RKF49R9X	Panasonic
R201, R202, R203	3	47k	RES, 47 k, 5%, 0.1 W, AEC-Q200 Grade 0, 0603	CRCW060347K0JNEA	Vishay-Dale
R206, R208, R209, R210, R211	5	0	RES, 0, 5%, 0.1 W, 0603	RC0603JR-070RL	Yageo
R501	1	5.60k	RES, 5.60 k, 0.1%, 0.1 W, 0603	RG1608P-562-B-T5	Susumu Co Ltd
R502	1	18.2k	RES, 18.2 k, 1%, 0.1 W, AEC-Q200 Grade 0, 0603	CRCW060318K2FKEA	Vishay-Dale
R504	1	1.80k	RES, 1.80 k, 0.1%, 0.1 W, 0603	RT0603BRD071K8L	Yageo America
S1, S2, S4	3		Switch, SPST 4 Pos, Top Actuated, SMT	219-4LPST	CTS Electrocomponents
S3	1		Switch, Slide, SPST 2 poles, SMT	219-2LPST	CTS Electrocomponents
S5, S6	2		Switch, Tactile, SPST-NO, 0.05A, 12V, SMT	FSM4JSMA	TE Connectivity
SH1, SH2, SH4, SH5, SH6	5	1x2	Shunt, 100mil, Gold plated, Black	SNT-100-BK-G	Samtec
TP2, TP5, TP41	3		Test Point, Miniature, Red, TH	5000	Keystone
TP19, TP20, TP21, TP22, TP23, TP24, TP25, TP26	8		Test Point, Miniature, Black, TH	5001	Keystone

Table 5-1. EVM Bill of Materials (BOM) (continued)

DESIGNATOR	QTY	VALUE	DESCRIPTION	PARTNUMBER	MANUFACTURER
TP31, TP32, TP33, TP34, TP35, TP36, TP37, TP38, TP39, TP40	10		Test Point, Miniature, SMT	5019	Keystone
U1	1		Ultra-Low Jitter Clock Synchronizer with JESD204B for Wireless Communications	LMK5B33414RGCR	Texas Instruments
U5	1		Single 2-Input Exclusive-OR Gate, DBV0005A (SOT-23-5)	SN74LVC1G86DBVR	Texas Instruments
U6	1		150-mA Ultra-Low Noise LDO for RF and Analog Circuits Requires No Bypass Capacitor, NGF0006A (WSON-6)	LP5900SD-3.3/NOPB	Texas Instruments
U7	1		4-Channel ESD Protection Array for High-Speed Data Interfaces, DRY0006A (USON-6)	TPD4E004DRYR	Texas Instruments
U8	1		25 MHz Mixed Signal Microcontroller with 128 KB Flash, 8192 B SRAM and 63 GPIOs, -40 to 85 degC, 80-pin QFP (PN), Green (RoHS & no Sb/Br)	MSP430F5529IPN	Texas Instruments
U9, U10, U11	3		800-mA Ultra-Low-Noise, High- PSRR LDO, DNT0012B (WSON-12)	LP38798SD-ADJ/NOPB	Texas Instruments
U500	1		3A Low Noise and Low Ripple buck converter, RPU0010A (VQFN-10)	TPS62913RPUT	Texas Instruments
Y1	1		SMD TCXO 7.0 * 5.0 48.000000MHz	7N48071001	TXC
Y6	1		Crystal, 24.000 MHz, 20pF, SMD	ECS-240-20-5PX-TR	ECS Inc.
C29, C35	0	10uF	CAP, CERM, 10 uF, 10 V, +/- 20%, X5R, 0603	C1608X5R1A106M080AC	TDK
C68, C73, C76	0	0.047uF	CAP, CERM, 0.047 µF, 25 V,+/- 5%, C0G/NP0, AEC-Q200 Grade 1, 0805	C0805C473J3GACTU	Kemet
C69, C74, C77	0	0.1uF	CAP, CERM, 0.1 µF, 50 V,+/- 5%, C0G/NP0, 1210	C3225C0G1H104J250AA	TDK
C81, C83, C84, C85, C87	0	0.1uF	CAP, CERM, 0.1 uF, 25 V, +/- 5%, X7R, 0603	C0603C104J3RACTU	Kemet
C86, C88, C91, C95	0	100pF	CAP, CERM, 100 pF, 50 V, +/- 5%, C0G/NP0, 0603	06035A101JAT2A	AVX
C92, C93, C94	0	33pF	CAP, CERM, 33 pF, 100 V, +/- 5%, C0G/NP0, 0603	06031A330JAT2A	AVX
D11	0	7.5V	Diode, Zener, 7.5 V, 550 mW, SMB	1SMB5922BT3G	ON Semiconductor
J2, J3, J5	0		CONN SMA JACK STR EDGE MNT	CON-SMA-EDGE-S	RF Solutions Ltd.

Table 5-1. EVM Bill of Materials (BOM) (continued)

DESIGNATOR	QTY	VALUE	DESCRIPTION	PARTNUMBER	MANUFACTURER
R24	0	0	RES, 0, 5%, 0.1 W, AEC-Q200 Grade 0, 0603	CRCW06030000Z0EA	Vishay-Dale
R28, R35, R39	0	51	RES, 51, 5%, 0.0625 W, 0402	RC0402JR-0751RL	Yageo America
R29, R36	0	100	RES, 100, 1%, 0.1 W, AEC-Q200 Grade 0, 0603	CRCW0603100RFKEA	Vishay-Dale
R42	0	49.9	RES, 49.9, 1%, 0.1 W, AEC-Q200 Grade 0, 0603	CRCW060349R9FKEA	Vishay-Dale
R45, R75	0	10k	RES, 10 k, 5%, 0.1 W, AEC-Q200 Grade 0, 0603	CRCW060310K0JNEA	Vishay-Dale
R46, R47, R48, R49, R50	0	33	RES, 33, 5%, 0.063 W, AEC-Q200 Grade 0, 0402	CRCW040233R0JNED	Vishay-Dale
R59, R60	0	1.5k	RES, 1.5 k, 5%, 0.1 W, AEC-Q200 Grade 0, 0603	CRCW06031K50JNEA	Vishay-Dale
R78, R79, R82, R85, R86, R88, R90, R92, R94, R96, R99, R101, R103, R105, R109, R111, R113, R115, R117, R119, R121, R122, R125, R127, R129, R131, R133, R134, R135, R136, R137, R138, R139, R140, R141, R142, R143, R167, R169, R175, R176, R177, R178, R179, R180, R181, R182, R183, R184, R185, R186, R187, R188, R189, R190, R191, R204, R205	0	49.9	RES, 49.9, 1%, 0.1 W, AEC-Q200 Grade 0, 0402	ERJ-2RKF49R9X	Panasonic
R192, R193	0	100	RES, 100, 1%, 0.063 W, AEC-Q200 Grade 0, 0402	CRCW0402100RFKED	Vishay-Dale
R207	0	0	RES, 0, 5%, 0.1 W, 0603	RC0603JR-070RL	Yageo
TP1, TP4, TP7, TP501	0		Test Point, Miniature, Red, TH	5000	Keystone
TP30	0		Test Point, Miniature, SMT	5019	Keystone
U4	0		CDC64XX-2520, DLF0006A (VSON-6)	CDC64XX-2520	Texas Instruments
Y2	0		Crystal, 48 MHz, 15 pF, SMD	8W48072003	TXC Corporation
Y3	0		Crystal, Sealed Locked 50 MHz, 15pF, SMD	7X-50.000MBB-T	TXC Corporation
Y4	0		MERCURY+ 38.88MHz OCXO CMOS Oscillator 2.7 ~ 5V 4-SMD	ROM9070PA	Rakon
Y5	0		STANDARD OCXO 10MHz Frequency	ROX2522S4	Rakon

5.1 Loop Filter and Vibration Nonsensitive Capacitors

The capacitors used on the EVM are X7R, which are ferromagnetic and therefore are sensitive to vibration due to the piezoelectric effect. TI recommends to use non-ferromagnetic capacitors such as NP0, C0G, or Tantalum for applications in which optimal performance is required in the presence of vibration.

At and below 47 nF, C0G/NP0 capacitors are available in 0805 sized packages. For values 0.1 μ F and above, Tantalum capacitors may be considered for vibration immune loop filter components.

Table 5-2. Examples of Substitute Capacitors Which are Vibration Immune

CAPACITOR VALUE	VIBRATION SENSITIVE, X7R	VIBRATION IMMUNE
3.3 nF	C0603C332K5RACTU, 0603	GRM1885C1H332JA01D, C0G/NP0, 0603
33 nF	C0603C333J3RACTU, 0603	C2012C0G1H333J125AA, C0G/NP0, 0805
47 nF	06035C473JAT2A, 0603	C0805X473G3GEC7800, C0G/NP0, 0805 C0805C473J3GACTU, C0G/NP0, 0805
0.1 μ F	C0603C104J3RACTU, 0603	GRM31C5C1E104JA01L, C0G/NP0, 1206 TAJR104K020RNJ, Tantalum, 0805
0.47 μ F	GRM188R71A474KA61D, 0603	F921C474MPA, Tantalum, 0805

6 Appendix A - TICS Pro LMK5B33414 Software

6.1 Using the Start Page

The Start page can be used to configure the PLLs for specific VCO frequencies and DPLL operation.

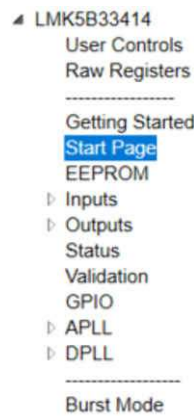

Figure 6-1. Start Page Location

6.1.1 Step 1

Set up the XO_P input frequency and interface type. Set up the input to the APLL by specifying the reference to each PLL and associated settings for PLL phase detector frequency.

6.1.2 Step 2

Set up the clock input frequencies and the interface type. Cascaded APLLs can also be assigned from this page using the PLL R-divider and phase detector preview to the right.

Step 1: XO Input

XO_P	Freq. (MHz) 48.0 <small>Range: 10 to 100 MHz</small>	Interface Type 8: CMOS
-------------	--	---------------------------

Step 2: Clock Inputs

	Freq. (MHz)	Interface Type
IN0 (REF0)	25.0	12: S-E (int. 50 ohm)
IN1 (REF1)	25.0	3: LVDS/HSDS (AC-DIFF, int. 10)
IN2 (REF2)	25.0	3: LVDS/HSDS (AC-DIFF, int. 10)
IN3 (REF3)	25.0	3: LVDS/HSDS (AC-DIFF, int. 10)

a) Range: Up to 750 MHz
b) Enter '0' when the input is never used.

Note: VCO Feedback frequencies may not be properly updated until after VCO frequencies are calculated.

PLL	VCO3 feedback	R Divider & Doubler	APLL Phase Detector Frequency
PLL1	VCO3 feedback 1250.0 MHz	13 <input type="checkbox"/> Bypass <input type="checkbox"/> DBLR	96.153846 MHz
PLL2	VCO3 feedback 1250.0 MHz	13 <input type="checkbox"/> Bypass <input type="checkbox"/> DBLR	96.153846 MHz
PLL3	XO 48.0 MHz	2 <input checked="" type="checkbox"/> Bypass <input checked="" type="checkbox"/> DBLR	96.0 MHz

Figure 6-2. Step 1 and 2: XO Input and Clock Inputs

6.1.3 Step 3

Set the clock input select mode for the DPLLs, input priority, and maximum TDC frequency. The recommended Input Select Mode is *Auto Revertive*. REF0, REF1, REF2, and REF3 shown below correspond with IN0, IN1, IN2, and IN3, respectively. REF4 and REF5 priorities can be set if the DPLLs input will be fed from one of the APLL post divider frequencies. The corresponding APLL is listed next to the REF4 and REF5. The REF with the highest priority will be fed as the DPLL input.

DPLL	Use DPLL	Input Select Mode	Manual Selection	Pin / Register Select	REF0 Priority	REF1 Priority	REF2 Priority	REF3 Priority	REF4 Priority	REF5 Priority	Max TDC Freq (MHz)	Actual DPLL TDC Freq (MHz)
DPLL1	<input type="checkbox"/>	Auto Revertive	REF0	Register	Not available	Not available	Not available	Not available	Not available	Not available	26	3.125
DPLL2	<input checked="" type="checkbox"/>	Auto revertive	REF0	Register	2nd	1st	3rd	4th	Not available	n/a (from PLL1)	26	25.0
DPLL3	<input checked="" type="checkbox"/>	Auto revertive	REF0	Register	2nd	1st	3rd	4th	Not available	n/a (from PLL1)	26	25.0

Figure 6-3. Step 3: DPLL Clock Input Selection

6.1.4 Step 4

Set the clock output for ZDM. The PLL will drive the PLL source mux for the selected output set for ZDM.

Figure 6-4. Step 4: Zero Delay Mode

6.1.5 Step 5

Enter the desired target frequencies for each output, as well as the desired output format, output source, whether the output is SYSREF, and whether the output is being used or not.

Press the *Calculate VCO Frequency Options* button to generate a list of possible VCO frequency combinations.

Step 5: Clock Outputs

a) Select the target frequency for each channel or output group.
 b) Select the output format. Unused outputs should be disabled to reduce power consumption.
 c) When applicable select V_{OS} to specify common mode. V_{OS} is a function of output swing and V_{OS} setting
 d) Generate possible VCO frequencies and choose from available options (or set overrides).
 e) Calculate the N-divider settings and DPLL-corrected PPM offsets.
 f) Export clock output settings to the device. "Actual Freq. (MHz)" boxes will update accordingly.

	Target Freq. (MHz)	Output Source	Output Format	Output Vcm	SYSREF?	Actual Freq. (MHz)
OUT0	25.0	PLL3	CMOS 1.8-V, P/N = On	Setting 1, Vcm = None V	<input type="checkbox"/>	25.0
OUT1	100.0	PLL3	HCSL 750 mV	Setting 1, Vcm = None V	<input type="checkbox"/>	100.0
OUT2	100.0	PLL3	HCSL 750 mV	Setting 1, Vcm = None V	<input type="checkbox"/>	100.0
OUT3	100.0		HCSL 750 mV	Setting 1, Vcm = None V	<input type="checkbox"/>	100.0
OUT4	161.1328125	PLL2	HSDS 500 mV, Vcm = 0.4 V	Setting 1, Vcm = None V	<input type="checkbox"/>	161.1328125
OUT5	161.1328125		HSDS 500 mV, Vcm = 0.4 V	Setting 1, Vcm = None V	<input type="checkbox"/>	161.1328125
OUT6	322.265625		HSDS 1000 mV, Vcm = 0.65 V	Setting 1, Vcm = None V	<input type="checkbox"/>	322.265625
OUT7	322.265625		HSDS 1000 mV, Vcm = 0.65 V	Setting 1, Vcm = None V	<input type="checkbox"/>	322.265625
OUT8	156.25	PLL3	HSDS 700 mV, Vcm = 0.9 V	Setting 2+3, Vcm = None	<input type="checkbox"/>	156.25
OUT9	156.25		HSDS 700 mV, Vcm = 0.9 V	Setting 2+3, Vcm = None	<input type="checkbox"/>	156.25
OUT10	156.25		HSDS 700 mV, Vcm = 0.9 V	Setting 2+3, Vcm = None	<input type="checkbox"/>	156.25
OUT11	156.25		HSDS 700 mV, Vcm = 0.9 V	Setting 2+3, Vcm = None	<input type="checkbox"/>	156.25
OUT12	312.5	PLL3	HSDS 500 mV, Vcm = 0.4 V	Setting 1, Vcm = None V	<input type="checkbox"/>	312.5
OUT13	312.5		HSDS 1000 mV, Vcm = 0.65 V	Setting 1, Vcm = None V	<input type="checkbox"/>	312.5

Frequency plan updated. Press Calculate VCO Frequency Options"

Calculate VCO Frequency Options

Copy to Selected VCO Frequency

Enable User Override

VCO Frequency User Override:

VCO1 4976.64 MHz

VCO2 5800.78125 MHz

VCO3 2500.0 MHz

Assign Selected VCO Settings to Device

Apply Output Clock Settings to Device

Analog VCO ppm error (corrected by DPLL)

	Integer	Numerator	Analog VCO ppm error (corrected by DPLL)
VCO1	51	832391874878	7.24938030185E-09
VCO2	60	360777252864	0.0
VCO3	26	45812984491	1.16415321827e-08

VC01 Frequency Options

VC02 Frequency Options

5800.78125

VC03 Frequency: 2500.0 MHz

Output Mute Options

PLL1	PLL2	PLL3
<input type="checkbox"/> MUTE_APLL1_LOCK	<input type="checkbox"/> MUTE_APLL2_LOCK	<input type="checkbox"/> MUTE_APLL3_LOCK
<input type="checkbox"/> MUTE_DPLL1_FRLOCK	<input type="checkbox"/> MUTE_DPLL2_FRLOCK	<input type="checkbox"/> MUTE_DPLL3_FRLOCK
<input type="checkbox"/> MUTE_DPLL1_PHLOCK	<input type="checkbox"/> MUTE_DPLL2_PHLOCK	<input type="checkbox"/> MUTE_DPLL3_PHLOCK

Figure 6-5. Step 5: Clock Outputs

Select a desired combination of VCO frequencies from the list of calculated values. If a specific VCO frequency is not in this list, a manual override can occur by selecting the *Enable User Override* checkbox and typing in the desired VCO frequencies. The *Copy to Selected VCO Frequency* box can also be used to copy the VCO frequency in the list selections to the VCO overrides.

Press the *Assign Selected VCO Settings to Device* button to update the VCO frequencies, then press the *Apply Output Clock Settings to Device* button. By default, the analog PLL frequencies are shown. The DPLL calculated frequency from step 6, however, will result in exact output frequencies.

After the output frequency plan is calculated, ensure that a valid XO input is fed into the device so the APLLs can lock and generate the required frequencies. The device will not output any clocks until all enabled APLLs are locked.

6.1.6 Step 6

For step 6, simply enter the desired DPLL loop bandwidth.

Note

Any time an approximate symbol is shown, you can mouseover the tool tip to see exact output frequency.

Step 6: PLLs
Update red fields to control the DPLL characteristics.
The transfer function and error function allowed peaking can be left at the default values, if there is no application requirement specifying these values.
Running the script will yield attenuation values (in dB) for the specified transfer/error function offsets.

Parameter	DPLL1	DPLL2	DPLL3
VCO1 Freq. (MHz)	-4976.640000	VCO2 Freq. (MHz)	5800.78125
VCO3 Freq. (MHz)			2500.0
Range	4800e6 to 5350e6	5595e6 to 5950e6	2500 MHz +/- 100 ppm
Target	1	100	100
Actual	1.015	100.805	100.805
DPLL LBW (Hz)	0.1	0.1	0.1
DPLL Transfer Function Allowed Peaking (dB)	1	1	1
DPLL Error Function Allowed Peaking (dB)	0.1	0.1	0.1
DCO Step Size (ppb)	n/a	n/a	n/a
Transfer Function Attenuation	100	100	100
Error Function Attenuation	-79.46 dB	-3.03 dB	-3.03 dB
Offset (Hz)	100	100	100
	-6.0 dB	-1.13 dB	-1.12 dB

Figure 6-6. Step 6: PLLs

6.1.7 Step 7

To calculate the DPLL divider settings, select the desired DPLL loop filters and dividers and press the *Run Script* button. The software will run and calculate the necessary settings for the selected DPLL loop filters.

Step 7: Run Script
When red fields are changed, click **Calculate DPLL Settings** to generate updated DPLL settings for selected DPLLs below.

Calc DPLL1
 Calc DPLL2
 Calc DPLL3

Bypass run script warning

Run Script

If ZDM mode is being used for a DPLL, re-run step 5
"Assign Selected VCO Settings to Device" and "Apply Output Clock Settings to Device" to set DPLL dividers for ZDM.

Figure 6-7. Step 7: Run Script

6.2 Using the Status Page

The Status page shows fields pertaining to the current status of the device. To update these fields, press the *Read Status Bits* button or the *Read RO Regs* button in the toolbar. The *Read RO Regs* button will read all read only registers which provides more information on other pages including the status fields but can take longer to read back. The *read status bits* just reads the status bits for this page.

For the DPLL to lock, a reference must be validated and selected in the *Active Reference/Holdover* and *Reference Validated* portions of the window shown in [Figure 6-8](#).

As the DPLL locks, it is expected to see the LOPL_DPLLx as the last bit to become clear when the phase lock is acquired.

When INT_EN = 1, any live status flag which occurs will latch to the INTR Latched bit columns. These will remain asserted until the *Clear Latched Bits* button is pressed. This gives additional insight into the behavior of the device.

Press the *Soft-chip reset* button in the toolbar to reset the device and restart the lock.

Read Status	INTR Source Live Status (read only)	INTR Flag Polarity 0 = Normal Polarity 1 = Inverted Polarity	INTR Latched Bits Clear Latched Bits	INTR Status Mask 0 = Route to Interrupt 1 = Mask (ignore)	Latch Mode INT_EN OR
APLLs XO	<input checked="" type="checkbox"/> LOL_PLL1 <input type="checkbox"/> LOL_PLL2 <input type="checkbox"/> LOS_FDET_XO	<input type="checkbox"/> LOL_PLL1_POL <input type="checkbox"/> LOL_PLL2_POL <input type="checkbox"/> LOS_FDET_XO_POL	<input type="checkbox"/> LOL_PLL1_INTR <input type="checkbox"/> LOL_PLL2_INTR <input type="checkbox"/> LOS_FDET_XO_INTR	<input type="checkbox"/> LOL_PLL1_MASK <input type="checkbox"/> LOL_PLL2_MASK <input type="checkbox"/> LOS_FDET_XO_MASK	<input checked="" type="checkbox"/> INT_EN
DPLL1	<input type="checkbox"/> LOR_MISSCLK1 <input type="checkbox"/> LOR_FREQ1 <input type="checkbox"/> LOR_PH1 <input type="checkbox"/> REFSWITCH1 <input checked="" type="checkbox"/> LOPL_DPLL1 <input checked="" type="checkbox"/> LOFL_DPLL1 <input checked="" type="checkbox"/> HLDOVR1 <input type="checkbox"/> HIST1	<input type="checkbox"/> LOR_MISSCLK1_POL <input type="checkbox"/> LOR_FREQ1_POL <input type="checkbox"/> LOR_PH1_POL <input type="checkbox"/> REFSWITCH1_POL <input type="checkbox"/> LOPL_DPLL1_POL <input type="checkbox"/> LOFL_DPLL1_POL <input type="checkbox"/> HLDOVR1_POL <input type="checkbox"/> HIST1_POL	<input type="checkbox"/> LOR_MISSCLK1_INTR <input type="checkbox"/> LOR_FREQ1_INTR <input type="checkbox"/> LOR_PH1_INTR <input type="checkbox"/> REFSWITCH1_INTR <input type="checkbox"/> LOPL_DPLL1_INTR <input type="checkbox"/> LOFL_DPLL1_INTR <input type="checkbox"/> HLDOVR1_INTR <input type="checkbox"/> HIST1_INTR	<input type="checkbox"/> LOR_MISSCLK1_MASK <input type="checkbox"/> LOR_FREQ1_MASK <input type="checkbox"/> LOR_PH1_MASK <input type="checkbox"/> REFSWITCH1_MASK <input type="checkbox"/> LOPL_DPLL1_MASK <input type="checkbox"/> LOFL_DPLL1_MASK <input type="checkbox"/> HLDOVR1_MASK <input type="checkbox"/> HIST1_MASK	Active Reference/Holdover 2: REF1 2: REF1 2: REF1 Reference Validated <input checked="" type="checkbox"/> REF0_VALID_STATUS <input checked="" type="checkbox"/> REF1_VALID_STATUS <input checked="" type="checkbox"/> REF2_VALID_STATUS <input checked="" type="checkbox"/> REF3_VALID_STATUS <input type="checkbox"/> REF0_FDET_STATUS <input type="checkbox"/> REF0_PH_STATUS <input type="checkbox"/> REF1_FDET_STATUS <input type="checkbox"/> REF1_PH_STATUS <input type="checkbox"/> REF2_FDET_STATUS <input type="checkbox"/> REF2_PH_STATUS <input type="checkbox"/> REF3_FDET_STATUS <input type="checkbox"/> REF3_PH_STATUS
DPLL2	<input type="checkbox"/> LOR_MISSCLK2 <input type="checkbox"/> LOR_FREQ2 <input type="checkbox"/> LOR_PH2 <input type="checkbox"/> REFSWITCH2 <input type="checkbox"/> LOPL_DPLL2 <input type="checkbox"/> LOFL_DPLL2 <input type="checkbox"/> HLDOVR2 <input type="checkbox"/> HIST2	<input type="checkbox"/> LOR_MISSCLK2_POL <input type="checkbox"/> LOR_FREQ2_POL <input type="checkbox"/> LOR_PH2_POL <input type="checkbox"/> REFSWITCH2_POL <input type="checkbox"/> LOPL_DPLL2_POL <input type="checkbox"/> LOFL_DPLL2_POL <input type="checkbox"/> HLDOVR2_POL <input type="checkbox"/> HIST2_POL	<input type="checkbox"/> LOR_MISSCLK2_INTR <input type="checkbox"/> LOR_FREQ2_INTR <input type="checkbox"/> LOR_PH2_INTR <input type="checkbox"/> REFSWITCH2_INTR <input type="checkbox"/> LOPL_DPLL2_INTR <input type="checkbox"/> LOFL_DPLL2_INTR <input type="checkbox"/> HLDOVR2_INTR <input type="checkbox"/> HIST2_INTR	<input type="checkbox"/> LOR_MISSCLK2_MASK <input type="checkbox"/> LOR_FREQ2_MASK <input type="checkbox"/> LOR_PH2_MASK <input type="checkbox"/> REFSWITCH2_MASK <input type="checkbox"/> LOPL_DPLL2_MASK <input type="checkbox"/> LOFL_DPLL2_MASK <input type="checkbox"/> HLDOVR2_MASK <input type="checkbox"/> HIST2_MASK	<input type="checkbox"/> REF2_FDET_STATUS <input type="checkbox"/> REF2_PH_STATUS <input type="checkbox"/> REF3_FDET_STATUS <input type="checkbox"/> REF3_PH_STATUS
DPLL3	<input type="checkbox"/> LOR_MISSCLK3 <input type="checkbox"/> LOR_FREQ3 <input type="checkbox"/> LOR_PH3 <input type="checkbox"/> REFSWITCH3 <input type="checkbox"/> LOPL_DPLL3 <input type="checkbox"/> LOFL_DPLL3 <input type="checkbox"/> HLDOVR3 <input type="checkbox"/> HIST3	<input type="checkbox"/> LOR_MISSCLK3_POL <input type="checkbox"/> LOR_FREQ3_POL <input type="checkbox"/> LOR_PH3_POL <input type="checkbox"/> REFSWITCH3_POL <input type="checkbox"/> LOPL_DPLL3_POL <input type="checkbox"/> LOFL_DPLL3_POL <input type="checkbox"/> HLDOVR3_POL <input type="checkbox"/> HIST3_POL	<input type="checkbox"/> LOR_MISSCLK3_INTR <input type="checkbox"/> LOR_FREQ3_INTR <input type="checkbox"/> LOR_PH3_INTR <input type="checkbox"/> REFSWITCH3_INTR <input type="checkbox"/> LOPL_DPLL3_INTR <input type="checkbox"/> LOFL_DPLL3_INTR <input type="checkbox"/> HLDOVR3_INTR <input type="checkbox"/> HIST3_INTR	<input type="checkbox"/> LOR_MISSCLK3_MASK <input type="checkbox"/> LOR_FREQ3_MASK <input type="checkbox"/> LOR_PH3_MASK <input type="checkbox"/> REFSWITCH3_MASK <input type="checkbox"/> LOPL_DPLL3_MASK <input type="checkbox"/> LOFL_DPLL3_MASK <input type="checkbox"/> HLDOVR3_MASK <input type="checkbox"/> HIST3_MASK	Other Status Registers <input checked="" type="checkbox"/> PLL1_VM_INSIDE <input checked="" type="checkbox"/> PLL2_VM_INSIDE <input type="checkbox"/> TEC_CNTR_HELD
					Bypass Status Controls <input type="checkbox"/> XO_FDET_BYP

Figure 6-8. Status Page

6.3 Using the Input Page

The Input page provides a high-level view of all the inputs for the device, the APLL frequencies, and DPLL frequencies of the device.

When the DPLL dividers and loop filter are calculated by running the script in step 7 on the Start page, this page displays the DPLL divider values which set the DPLL frequency. This example shows that the DPLL frequency is the exact desired frequency.

Each DPLL supports two sets of DPLL dividers which can be selected. At this time, the tool calculates the divider for FB Config 1 only. To use two different feedback dividers, the following procedure should be preformed.

- Div #1 settings may be copied into Div #2 settings and selected for use by the *DPLL Div Select* control.
- The references that require the Div #2 settings should be set to FB Config 2.
- You can run a second calculation (re-perform a run script, step 7 on Start page, of the DPLL), which will repopulate Div #1 settings with the new values for FB Config 1.
 - Div #2 settings will remain the same as the ones initial copied over in step 1.

When using both feedback dividers, it is not required that the TDC rates are exactly the same, only that they are within $\pm 5\%$ for the two DPLL feedback configurations.

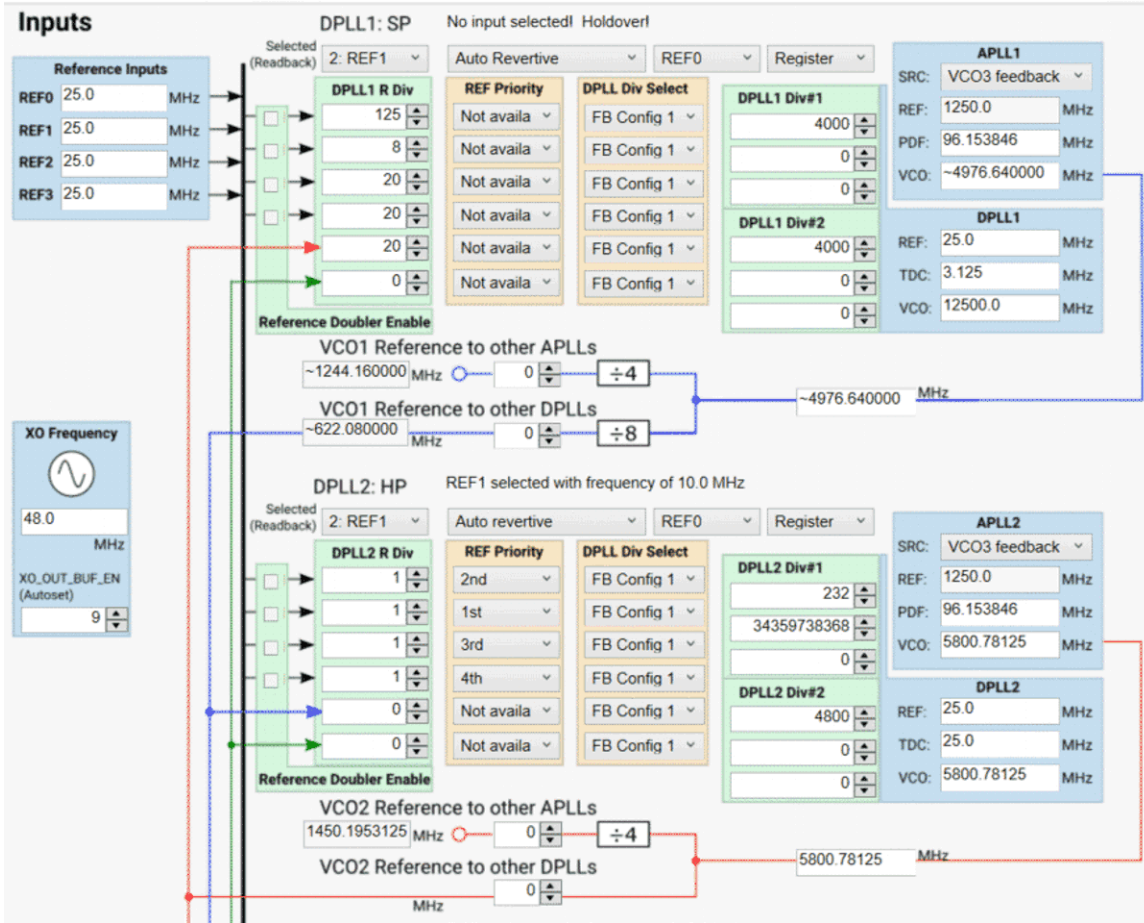

Figure 6-9. APLL or DPLL Frequency Selection

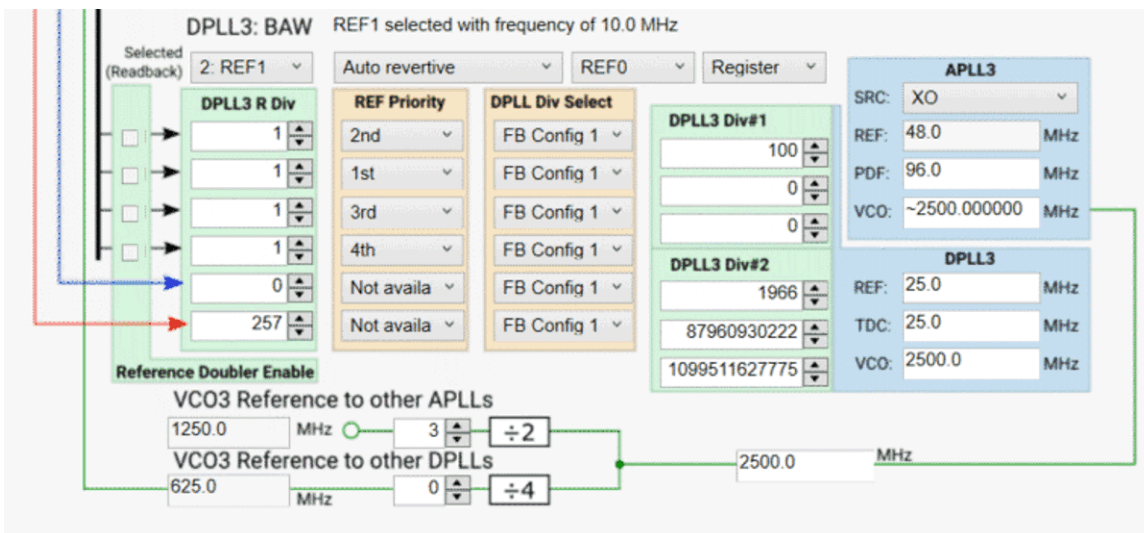

Figure 6-10. PLL3 Input

6.3.1 Cascaded Configurations

Cascaded configurations can be created using the input page, where the relevant VCO buffers and dividers will automatically be enabled by inferring the state of source selection registers.

At least one PLL must always be active and set to XO reference source for cascaded configurations to be valid. APLL start-up priority will automatically choose XO-source APLLs to start up before all other PLLs whenever possible. Start-up priority cannot be properly inferred, therefore users must set this priority themselves in the *User Controls* page if in pin-selection mode. In the example image below, APLL3 is referenced to XO input and APLL1 and APLL2 are referenced from APLL3. Priority is controlled in ascending order, with 0 first and 2 last. APLLs can share priorities; if all APLL priorities are set to 0, all APLLs will start up simultaneously.

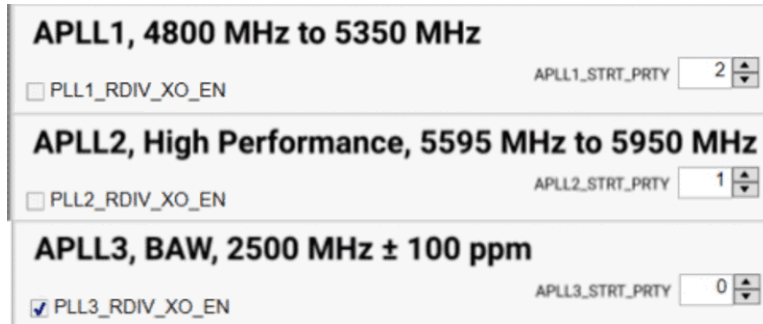
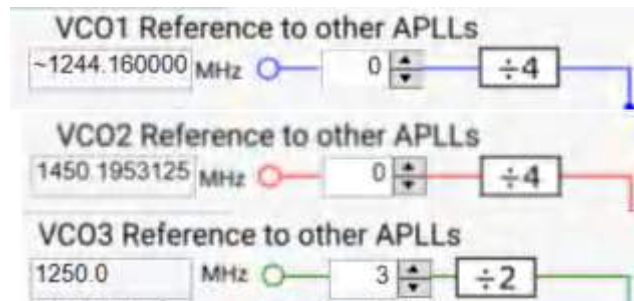

Figure 6-11. Cascade APLL Start Priorities

6.3.1.1 Cascade VCO to APLL Reference

Cascading APLLs is controlled by the APLL source box, circled in Figure 6-12. This box is programmed bitwise and is automatically set when generating a frequency plan. The XO_OUT_BUF_EN register in the *Input Control* section of the *User Controls* tab is automatically set to enable or disable the XO Output Buffer. The PLLx_RDIV_XO_EN is automatically checked/unchecked in each APLLx tab depending on whether each APLL is using the XO input.



Located on Inputs page

Figure 6-12. APLL Source Box

6.4 Using APLL1, APLL2, and APLL3 Pages

The APLL pages can be used to see detailed information on APLL behavior including the output dividers. It is possible to type a VCO frequency into the PLL1 VCO frequency box (as shown in red circle) to have the fractional N value re-calculated.

When the DPLL is not used, the APLLs support an APLL-only mode with a programmable 24-bit denominator. Support for this mode is currently not implemented in the TICS Pro software.

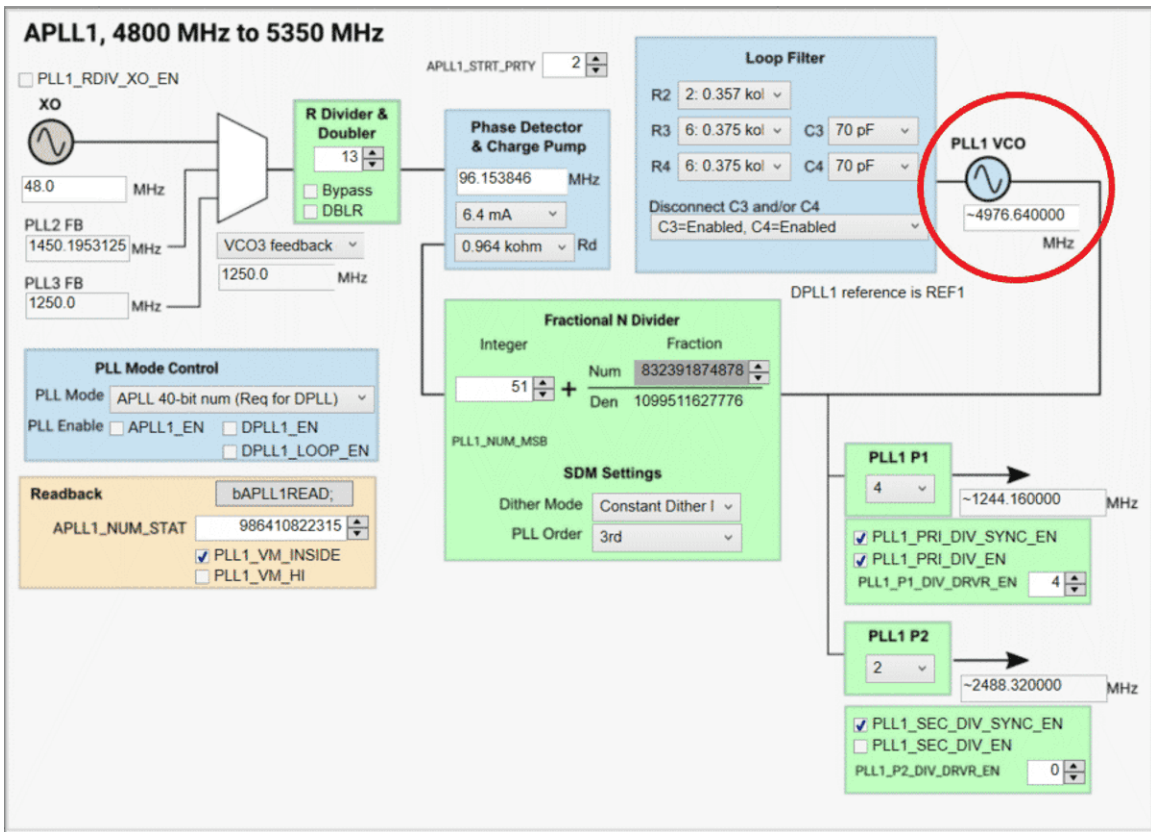

Figure 6-13. APLL1 Page

Figure 6-14 shows the post divider for PLL2. Figure 6-15 shows the post divider for PLL3. PLL3 supports all outputs of the LMK5B33414.

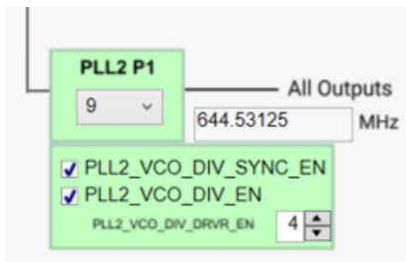

Figure 6-14. PLL2 Post Divider

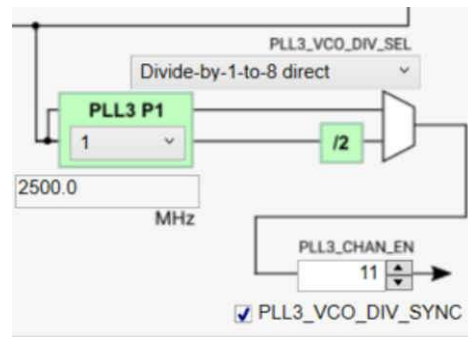

Figure 6-15. PLL3 Dividers

6.4.1 APLL DCO

To use the DCO shift controls on a given APLL, enter the DCO ppb step value into the *DCO Step Size (ppb)* box shown below. The entered step size will be used to calculate a numerator deviation and a 2s complement numerator deviation. To perform the shift, the increment or decrement button must be pressed. An increment will write the numerator deviation to the DPLLx_FREE_RUN control which will result in a positive frequency shift in the amount specified by the *DCO Step Size (ppb)*. An decrement will write the 2s complement numerator deviation to the DPLLx_FREE_RUN control which will result in a negative frequency shift in the amount specified by the *DCO Step Size (ppb)*.

The slew rate at which the adjustment will occur is set on the DPLLx_HOLD_SLEW_STEP control. Ensure the DPLLx_HOLD_SLEW_STEP is **NOT** equal to 0, otherwise the adjustment will not occur. The recommended DPLLx_HOLD_SLEW_STEP value is 63 (maximum value). A value of 63 will result in the fastest adjustment.

APLL DCO Frequency Control

1. When performing a DCO adjustment to the APLL effective numerator in either relative or absolute mode, the rate of change is limited by the APLL loop bandwidth. The change is applied in steps at the rate defined by a numerator delta every timer value. This enables further limiting of the rate of phase/frequency change.

2. In relative mode, every DPLL_FREE_RUN write adds to the effective APLL numerator. The effective APLL numerator can be read from RO field APLLx_NUM_STAT.

3. In absolute mode, the DPLL_FREE_RUN register is added to the programmed APLL numerator. The effective APLL numerator can be read from RO field APLLx_NUM_STAT.

APLL1 DCO Freq. Control Relative Frequency Adjustment

DCO - Relative DCO Adjust (enter either desired DCO step size or numerator deviation value)

DCO Step Size (ppb)	Actual Step Size (ppb)		numerator deviation		DPLL1_FREE_RUN	
<input type="text" value="0.01"/>	n/a	↔	<input type="text" value="0"/>	<input type="button" value="Increment"/>	<input type="text" value="0"/>	Frequency shift due to DCO adjustment (ppb offset) 0
			numerator deviation 2s complement	<input type="button" value="Decrement"/>		

DCO - Absolute DCO Adjust of APLL1 numerator value
Use the relative DCO step size to calculate what the DPLL1_FREE_RUN value should be for a desired ppb offset. For a negative ppb offset, use the 2s complement value.

DPLL1_FREE_RUN	+	Actual APLL1 Numerator	=	Effective APLL1 Numerator
<input type="text" value="0"/>		<input type="text" value="832391874877"/>		

APLL1 DCO - (DPLL in holdover). This will limit rate of APLL DCO. SLEW_STEP = 63 with small timer effectively disables slew limiting.

DPLL1_HOLD_SLEW_STEP	DPLL1_HOLD_TIMER	x2 ⁿ	=	Result
<input type="text" value="0"/>	<input type="text" value="322"/>	<input type="text" value="10"/>		<input type="text" value="2"/> = 1.60 us

APLL2 DCO Freq. Control Relative Frequency Adjustment

DCO - Relative DCO Adjust (enter either desired DCO step size or numerator deviation value)

DCO Step Size (ppb)	Actual Step Size (ppb)		numerator deviation		DPLL2_FREE_RUN	
<input type="text" value="0.01"/>	n/a	↔	<input type="text" value="0"/>	<input type="button" value="Increment"/>	<input type="text" value="0"/>	Frequency shift due to DCO adjustment (ppb offset) 0
			numerator deviation 2s complement	<input type="button" value="Decrement"/>		

DCO - Absolute DCO Adjust of APLL2 numerator value
Use the relative DCO step size to calculate what the DPLL2_FREE_RUN value should be for a desired ppb offset. For a negative ppb offset, use the 2s complement value.

DPLL2_FREE_RUN	+	Actual APLL2 Numerator	=	Effective APLL2 Numerator
<input type="text" value="0"/>		<input type="text" value="360777252863"/>		

APLL2 DCO - (DPLL in holdover). This will limit rate of APLL DCO. SLEW_STEP = 63 with small timer effectively disables slew limiting.

DPLL2_HOLD_SLEW_STEP	DPLL2_HOLD_TIMER	x2 ⁿ	=	Result
<input type="text" value="0"/>	<input type="text" value="322"/>	<input type="text" value="10"/>		<input type="text" value="2"/> = 1.52 us

APLL3 DCO Freq. Control Relative Frequency Adjustment

DCO - Relative DCO Adjust (enter either desired DCO step size or numerator deviation value)

DCO Step Size (ppb)	Actual Step Size (ppb)		numerator deviation		DPLL3_FREE_RUN	
<input type="text" value="0.01"/>	n/a	↔	<input type="text" value="0"/>	<input type="button" value="Increment"/>	<input type="text" value="0"/>	Frequency shift due to DCO adjustment (ppb offset) 0
			numerator deviation 2s complement	<input type="button" value="Decrement"/>		

DCO - Absolute DCO Adjust of APLL3 numerator value
Use the relative DCO step size to calculate what the DPLL3_FREE_RUN value should be for a desired ppb offset. For a negative ppb offset, use the 2s complement value.

DPLL3_FREE_RUN	+	Actual APLL3 Numerator	=	Effective APLL3 Numerator
<input type="text" value="0"/>				

Figure 6-16. APLL DCO Controls

6.5 Using the DPLL1, DPLL2, and DPLL3 Pages

The DPLL pages contain many advanced controls that are normally set during the *Run Script* calculation.

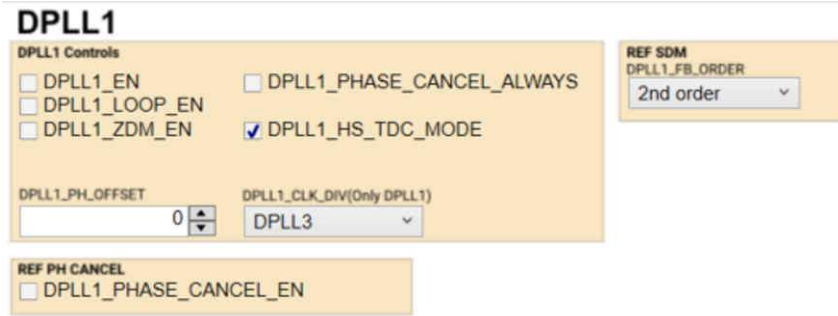

The screenshot shows the 'DPLL1' control interface. It features a main title 'DPLL1' and a section 'DPLL1 Controls' with the following elements:

- Four checkboxes: DPLL1_EN, DPLL1_LOOP_EN, DPLL1_ZDM_EN, and DPLL1_HS_TDC_MODE.
- Two additional checkboxes: DPLL1_PHASE_CANCEL_ALWAYS and DPLL1_PHASE_CANCEL_EN (located in a separate 'REF PH CANCEL' box).
- A numeric input field for 'DPLL1_PH_OFFSET' set to '0'.
- A dropdown menu for 'DPLL1_CLK_DIV(Only DPLL1)' set to 'DPLL3'.
- A dropdown menu for 'REF SDM DPLL1_FB_ORDER' set to '2nd order'.

Figure 6-17. Primary DPLL Controls

6.5.1 DPLL DCO

To use the DCO shift controls on a given DPLL, enter the DCO ppb step value into the *DCO Step Size (ppb)* box shown below. The entered step size will be used to calculate a frequency deviation that will be applied to the DPLL numerator. This frequency deviation is shown in the DPLLx_FDEV control. To perform the shift, you must press the increment or decrement button.

DPLL DCO Frequency Control

1. When performing a DCO adjustment to the DPLL numerator in either relative or absolute mode, the rate of change is limited by the DPLL loop bandwidth.
 2. In register relative mode, a relative adjustment of the DPLLx_FB_NUM is made by programming a deviation amount (DPLLx_FDEV) for each write to the address.
 3. When performing a GPIO relative adjustment, a relative adjustment of the DPLLx_FB_NUM is made by programming a deviation amount (DPLLx_FDEV) for each step in pin set direction.
 4. In absolute mode, the DPLLx_FB_NUM is written to based on the frequency control word (FCW).

DPLL1 DCO Freq. Control Relative: Incr/Decr via GPIO pins Selected Input: 0: Holdover FB Config: FB Config 1

DCO - Relative DCO Adjust (enter either desired DCO step size or DPLL1 numerator frequency deviation number) DPLL1_FDEV_EN GPIO_FDEV_EN

DCO Step Size (ppb) Actual (ppb) DPLL1_FDEV Increment Decrement

0.1 n/a 0

DCO - Absolute DCO Adjust (enter either desired ppb error or DPLL1 Numerator value) Original DPLL1 Numerator: Not calculated

Error from original Actual (ppb) Actual DPLL1 Numerator Reload Original DPLL Numerator

DPLL1 frequency (ppb) Not calculated 0

Frequency shift due to DCO adjustment (ppb error)

0

DPLL2 DCO Freq. Control Relative: Incr/Decr via GPIO pins Selected Input: 2: REF1 FB Config: FB Config 1

DCO - Relative DCO Adjust (enter either desired DCO step size or DPLL2 numerator frequency deviation number) DPLL2_FDEV_EN GPIO_FDEV_EN

DCO Step Size (ppb) Actual (ppb) DPLL2_FDEV Increment Decrement

0.1 n/a 0

DCO - Absolute DCO Adjust (enter either desired ppb error or DPLL2 Numerator value) Original DPLL2 Numerator: Not calculated

Error from original Actual (ppb) Actual DPLL2 Numerator Reload Original DPLL Numerator

DPLL2 frequency (ppb) Not calculated 0

Frequency shift due to DCO adjustment (ppb error)

0

DPLL3 DCO Freq. Control Relative: Incr/Decr via GPIO pins Selected Input: 2: REF1 FB Config: FB Config 1

DCO - Relative DCO Adjust (enter either desired DCO step size or DPLL3 numerator frequency deviation number) DPLL3_FDEV_EN GPIO_FDEV_EN

DCO Step Size (ppb) Actual (ppb) DPLL3_FDEV Increment Decrement

0.1 n/a 0

DCO - Absolute DCO Adjust (enter either desired ppb error or DPLL3 Numerator value) Original DPLL3 Numerator: Not calculated

Error from original Actual (ppb) Actual DPLL3 Numerator Reload Original DPLL Numerator

DPLL3 frequency (ppb) Not calculated 0

Frequency shift due to DCO adjustment (ppb error)

0

Figure 6-18. DPLL DCO Controls

6.6 Using the Validation Page

The Validation page allows you to enable/disable different detectors for reference validation along with DPLL frequency and phase lock requirements. Press the *Reassign All* button at the top of the page to recalculate the validation values.

Clock Input Validation (LOS) for input clock validation Reassign All

$T_{EARLY} < \text{Period of Reference} < T_{LATE}$

Validation Timer	Frequency Detect Threshold					Early Clk Window Detector			Missing Clk Window Detector						
	Enable	Valid. time	Enable	Valid* (ppm)	Invalid (ppm)	Accuracy (ppm)	Average (count)	Meas time	Enable	Margin	T_{EARLY}	Enable	Missing Clocks	Margin	T_{LATE}
REF0	<input checked="" type="checkbox"/>	1.6 s	<input checked="" type="checkbox"/>	100	150	10	1	2.08 ms	<input type="checkbox"/>	1	36.80 ns	<input checked="" type="checkbox"/>	1	3	84.80 ns
REF1	<input checked="" type="checkbox"/>	1.6 s	<input checked="" type="checkbox"/>	100	150	10	1	2.08 ms	<input type="checkbox"/>	1	36.80 ns	<input checked="" type="checkbox"/>	1	3	84.80 ns
REF2	<input type="checkbox"/>	1.6 s	<input type="checkbox"/>	70	100	10	1	n/a	<input type="checkbox"/>	0	37.60 ns	<input type="checkbox"/>	0	0	42.40 ns
REF3	<input type="checkbox"/>	1.6 s	<input type="checkbox"/>	70	100	10	1	n/a	<input type="checkbox"/>	0	37.60 ns	<input type="checkbox"/>	0	0	42.40 ns

*The minimum recommended valid Frequency Detect Threshold = maximum XO ppm error + maximum reference ppm error.

1 PPS Phase Detector

Enable	Threshold	$T_{PHASE-VALID}$
REF0	0	n/a; REF0 > 2 kHz
REF1	0	n/a; REF1 > 2 kHz
REF2	0	n/a
REF3	0	n/a

The 1 PPS Phase Detector requires ≤ 2 kHz reference frequency. Threshold is set to accommodate the jitter of the 1 PPS reference clock in periods of the XO reference clock.

DPLL1 Frequency Lock Detect DPLL1_LOCKDET_PPM_EN

Lock (ppm)	Unlock (ppm)	Average (count)	Accuracy (ppm)	T_{MEAS}
90	120	1	10	n/a

DPLL2 Frequency Lock Detect DPLL2_LOCKDET_PPM_EN

Lock (ppm)	Unlock (ppm)	Average (count)	Accuracy (ppm)	T_{MEAS}
90	120	1	10	1.03 ms

DPLL3 Frequency Lock Detect DPLL3_LOCKDET_PPM_EN

Lock (ppm)	Unlock (ppm)	Average (count)	Accuracy (ppm)	T_{MEAS}
90	120	1	10	960.00 us

DPLL3 DLD or BAW Lock:

DPLL1 Phase Lock Detect

Threshold	T_{MEAS}
Lock 27	112.56 ps
Unlock 29	450.24 ps

DPLL2 Phase Lock Detect

Threshold	T_{MEAS}
Lock 29	122.93 ps
Unlock 31	491.72 ps

DPLL3 Phase Lock Detect

Threshold	T_{MEAS}
Lock 29	284.84 ps
Unlock 31	1.14 ns

Figure 6-19. Validation Page

6.7 Using the GPIO Page

The GPIO page allows users to configure the GPIO0, GPIO1, and GPIO2 pins.

When using SPI readback on the EVM, GPIO2 must be configured as *STATUS* or *INT...* and *SDO output*. When using the device in I²C mode, refer to [Section 3.3](#).

GPIO Controls STATUS_MUX_DIV2_EN

GPIO0 GPIO0_IN_FLT_EN Active High NMOS open drain (external pull-
STATUS or INT, Acts as status or interrupt Interrupt (INTR). Derived from INT_FLAG

GPIO1 GPIO1_IN_FLT_EN Active High NMOS open drain (external pull-
STATUS or INT, Acts as status or interrupt Interrupt (INTR). Derived from INT_FLAG

GPIO2 GPIO2_IN_FLT_EN Active High NMOS open drain (external pull-
STATUS or INT, Acts as status or interrupt Interrupt (INTR). Derived from INT_FLAG

Time Elapsed Counter Controls

TEC_CNTR_EN

TEC trigger select SPI

TEC clock source VCO3

Read TEC 0

SYSREF to GPIO OUT_0_1

OUT_0_1_SR_GPIO_EN

OUT_4_5_SR_GPIO_EN

OUT_6_7_SR_GPIO_EN

OUT_8_9_SR_GPIO_EN

OUT_10_11_SR_GPIO_EN

OUT_12_13_SR_GPIO_EN

Figure 6-20. GPIO Page

6.8 SYNC/SYSREF/1-PPS Page

The SYNC/SYSREF/1-PPS page shows all the SYSREF block settings and allows the user to configure the GPIO1 or GPIO2 for continuous SYSREF or 1-PPS clock output.

The SYSREF divider output signals can be replicated on either GPIO1 and GPIO2 to provide additional single-ended, 3.3-V CMOS clocks after start-up if desired. To configure the SYSREF/1PPS output replication the GPIO must be enabled as an output (GPIOx_OUTEN = 1) and one of the SYSREF output to GPIO replication sources must be active. The SYSREF replication source comes from any one of the SYSREF dividers in use from OUT0/1, OUT4/5, OUT6/7, OUT/9, OUT10/11 or OUT12/13 by register programming (OUT_x_y_SR_GPIO_EN = 1 and GPIO_SYSREF_SEL to the appropriate OUT_x_y). The GPIOx replicated SYSREF output will be a continuous frequency. Pulsed SYSREF mode is not supported for the GPIOx replica outputs.

SYNC control

SYNC_EN
 SYNC_SW

SYSREF control

Software request for SYSREF pulses: SYSREF_REQ_SW

SYSREF resampling: (Recommended to enable)

SYSREF re-sample source: (if SYSREF resampling enabled)

SYSREF

	SYSREF Mode	Pulser Count	SYSREF Divide	SYSREF Divide Delay	SYSREF Divide Delay	Analog Delay
<input checked="" type="checkbox"/> OUT_0_1_SR_DIV_SYNC_EN	None	1	180	0	0	<input type="checkbox"/> ADLY EN
<input type="checkbox"/> OUT_4_5_SR_DIV_SYNC_EN	None	1	180	0	0	<input type="checkbox"/> ADLY EN
<input type="checkbox"/> OUT_6_7_SR_DIV_SYNC_EN	None	1	90	0	0	<input type="checkbox"/> ADLY EN
<input type="checkbox"/> OUT_8_9_SR_DIV_SYNC_EN	None	1	64	0	0	<input type="checkbox"/> ADLY EN
<input type="checkbox"/> OUT_10_11_SR_DIV_SYNC_EN	None	1	64	0	0	<input type="checkbox"/> ADLY EN
<input type="checkbox"/> OUT_12_13_SR_DIV_SYNC_EN	None	1	64	0	0	<input type="checkbox"/> ADLY EN

Continuous SYSREF or 1-PPS to GPIO
Note: even if SYSREF pulser is selected, GPIO output will be continuous.

Select source:

OUT_0_1_SR_GPIO_EN
 OUT_4_5_SR_GPIO_EN
 OUT_6_7_SR_GPIO_EN
 OUT_8_9_SR_GPIO_EN
 OUT_10_11_SR_GPIO_EN
 OUT_12_13_SR_GPIO_EN

Figure 6-21. SYNC/SYSREF/1-PPS Page

6.9 Using the Outputs Page

The Outputs page shows all the possible source frequencies to the output channels. To simplify settings fields necessary to providing an output frequency, a source mux lists all possible sources for each output. Be sure to enable or disable the desired outputs on the right-hand side of the screen.

There are many detailed output pages beneath the Outputs page that show the individual controls for each set of outputs.

The black box around OUT2 to OUT3, OUT4 to OUT7, and OUT8 to OUT13 signifies that all these outputs should source from the same VCO.

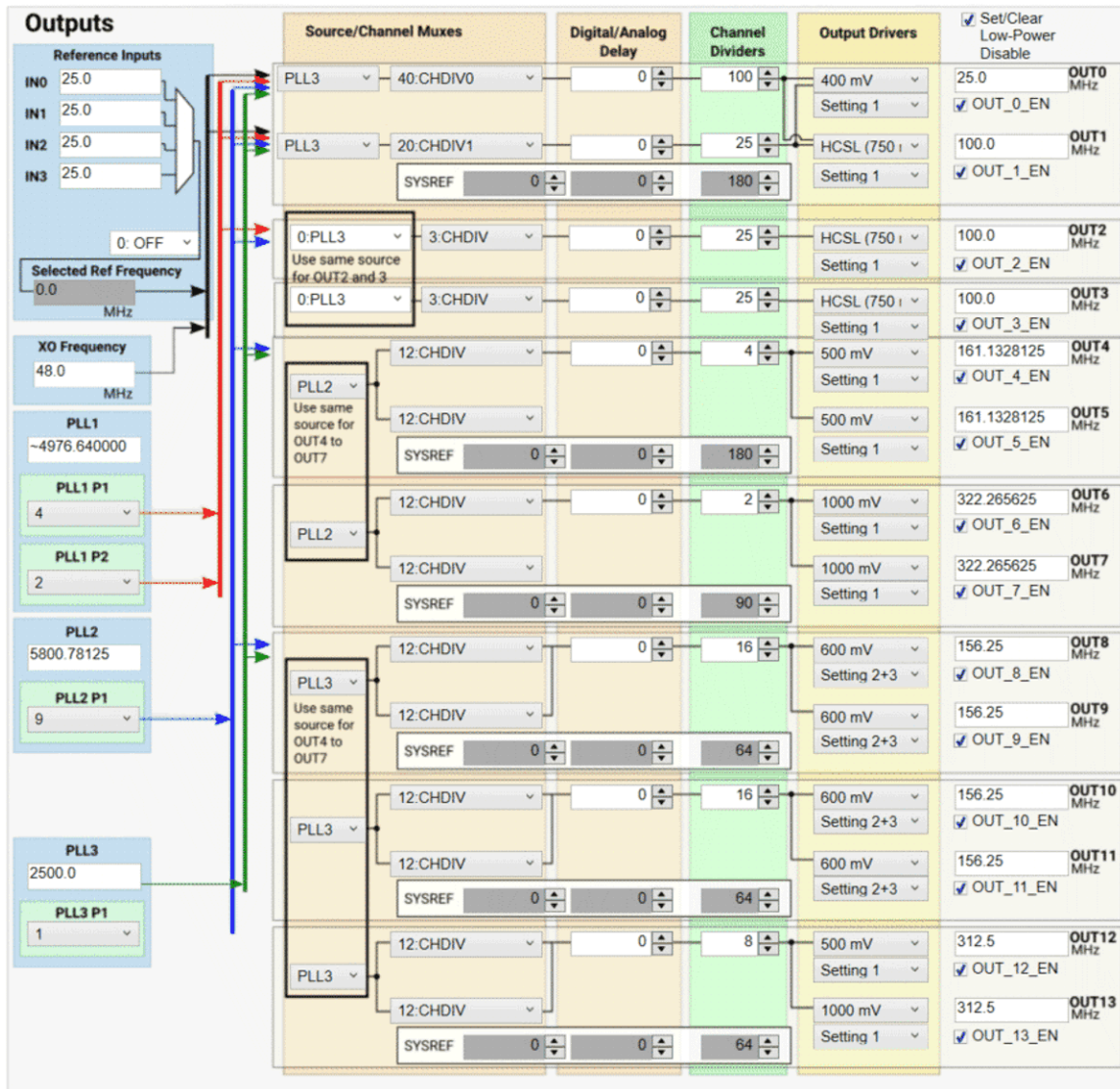

Reference Inputs	Source/Channel Muxes	Digital/Analog Delay	Channel Dividers	Output Drivers	Set/Clear Low-Power Disable
IN0: 25.0 IN1: 25.0 IN2: 25.0 IN3: 25.0	PLL3 - 40:CHDIV0	0	100	400 mV Setting 1	<input checked="" type="checkbox"/> OUT0_MHz
Selected Ref Frequency: 0.0 MHz	PLL3 - 20:CHDIV1	0	25	HCSL (750 i) Setting 1	<input checked="" type="checkbox"/> OUT_0_EN
XO Frequency: 48.0 MHz	SYSREF - 0	0	180	Setting 1	<input checked="" type="checkbox"/> OUT_1_MHz
PLL1: ~4976.640000	0:PLL3 - 3:CHDIV	0	25	HCSL (750 i) Setting 1	<input checked="" type="checkbox"/> OUT_2_MHz
PLL1 P1: 4	0:PLL3 - 3:CHDIV	0	25	HCSL (750 i) Setting 1	<input checked="" type="checkbox"/> OUT_2_EN
PLL1 P2: 2	Use same source for OUT2 and 3				<input checked="" type="checkbox"/> OUT_3_MHz
PLL2: 5800.78125	PLL2 - 12:CHDIV	0	4	500 mV Setting 1	<input checked="" type="checkbox"/> OUT_3_EN
PLL2 P1: 9	Use same source for OUT4 to OUT7				<input checked="" type="checkbox"/> OUT_4_MHz
PLL3: 2500.0	PLL2 - 12:CHDIV	0	2	1000 mV Setting 1	<input checked="" type="checkbox"/> OUT_4_EN
PLL3 P1: 1	PLL2 - 12:CHDIV	0	2	1000 mV Setting 1	<input checked="" type="checkbox"/> OUT_5_MHz
	SYSREF - 0	0	90	Setting 1	<input checked="" type="checkbox"/> OUT_5_EN
	PLL3 - 12:CHDIV	0	16	600 mV Setting 2+3	<input checked="" type="checkbox"/> OUT_6_MHz
	Use same source for OUT4 to OUT7				<input checked="" type="checkbox"/> OUT_6_EN
	PLL3 - 12:CHDIV	0	16	600 mV Setting 2+3	<input checked="" type="checkbox"/> OUT_7_MHz
	SYSREF - 0	0	64	Setting 2+3	<input checked="" type="checkbox"/> OUT_7_EN
	PLL3 - 12:CHDIV	0	16	600 mV Setting 2+3	<input checked="" type="checkbox"/> OUT_8_MHz
	Use same source for OUT4 to OUT7				<input checked="" type="checkbox"/> OUT_8_EN
	PLL3 - 12:CHDIV	0	16	600 mV Setting 2+3	<input checked="" type="checkbox"/> OUT_9_MHz
	SYSREF - 0	0	64	Setting 2+3	<input checked="" type="checkbox"/> OUT_9_EN
	PLL3 - 12:CHDIV	0	8	500 mV Setting 1	<input checked="" type="checkbox"/> OUT_10_MHz
	Use same source for OUT4 to OUT7				<input checked="" type="checkbox"/> OUT_10_EN
	PLL3 - 12:CHDIV	0	8	1000 mV Setting 1	<input checked="" type="checkbox"/> OUT_11_MHz
	SYSREF - 0	0	64	Setting 1	<input checked="" type="checkbox"/> OUT_11_EN
	PLL3 - 12:CHDIV	0	8	500 mV Setting 1	<input checked="" type="checkbox"/> OUT_12_MHz
	Use same source for OUT4 to OUT7				<input checked="" type="checkbox"/> OUT_12_EN
	PLL3 - 12:CHDIV	0	8	1000 mV Setting 1	<input checked="" type="checkbox"/> OUT_13_MHz
	SYSREF - 0	0	64	Setting 1	<input checked="" type="checkbox"/> OUT_13_EN

Figure 6-22. Outputs Page

6.10 EEPROM Page

The EEPROM page is used to write the currently loaded device settings into the device EEPROM. To program the EEPROM, press the *Program EEPROM* button.

Press the *Register commit method* button to display the registers that will be written to the EEPROM. The register sequence will populate under the OUTPUT section of [Figure 6-23](#), where you can copy the sequence and use it to program the device with your own tool if you do not wish to use the TICS Pro GUI.

EEPROM / NVM Status (read only)

Read EEPROM/NVM Status

CRC Error Status Stored CRC 0

NVM Program Count 36

I2C Target Address MSB 25 EEREV 0

Device start-up behavior

ROM Page Selection, GPIO0 & 2 add to this value on POR 0

Enable EEPROM overlay on POR

Write EEPROM

Program EEPROM

EEPROM Register Programming Sequence Generation

Before executing the register programming sequence, it is recommended to have just powered up or toggle the PD# pin to ensure known register state.

Design Name: Enter Design Name

User Notes: Enter User Notes

Generate register programming sequence using:

Register commit method

OUTPUT (display only)

EEPROM programming log or programming sequence will populate here

Save EEPROM output to text file

Figure 6-23. EEPROM Page

6.11 Design Report Page

The Design Report page shows an overview of the current profile settings.

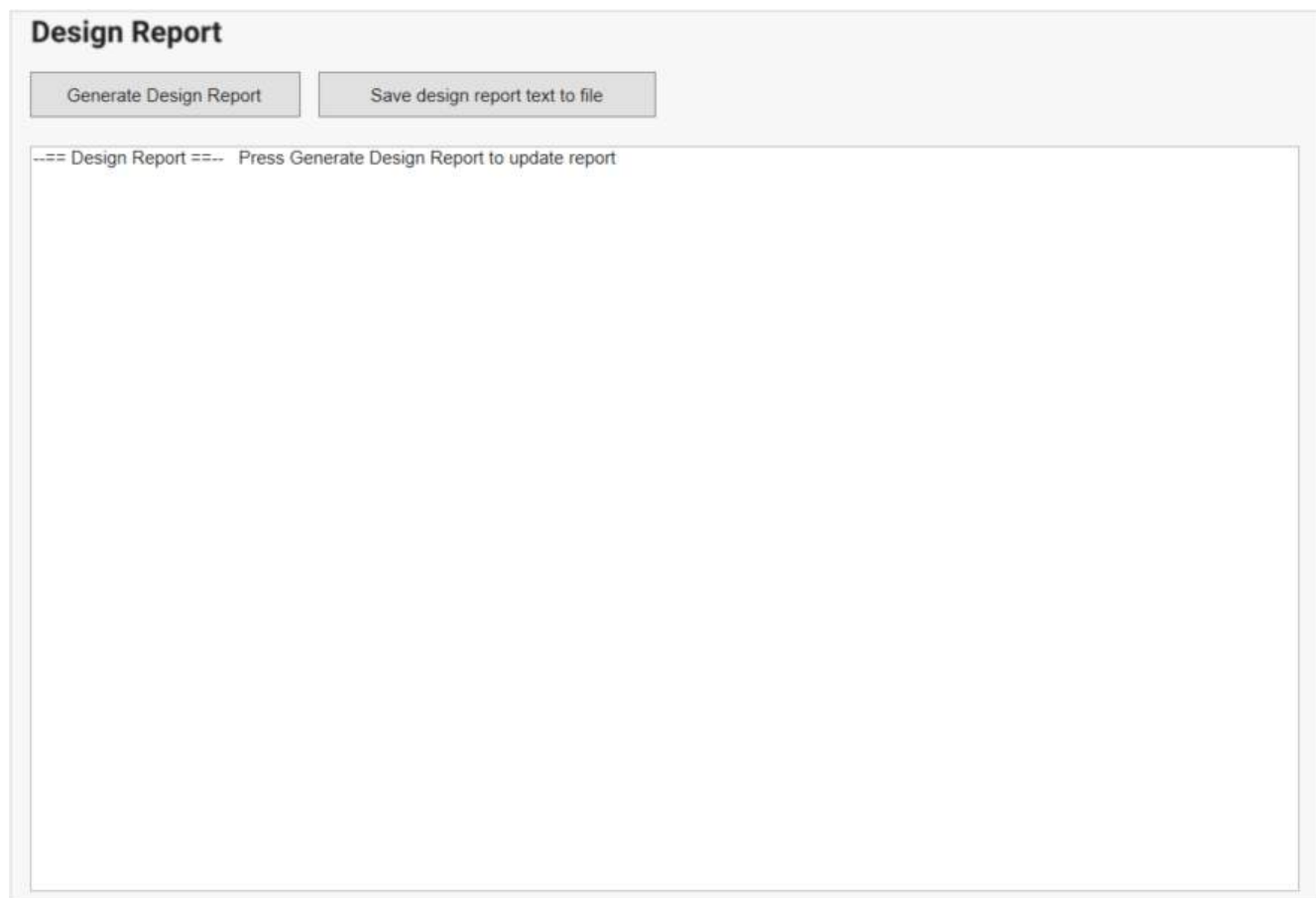

Figure 6-24. Design Report Page

7 Revision History

NOTE: Page numbers for previous revisions may differ from page numbers in the current version.

Changes from Revision * (July 2022) to Revision A (September 2022)	Page
• Changed <i>Overview</i> section.....	2
• Changed DC power supply from: 2 A to: 1 A.....	2
• Added the signal source analyzer and signal generator / reference clock to the recommended test equipment list.....	2
• Changed the power jumper from "adjacent designator" positions to opposite positions.....	4
• Changed Figure 2-1 and Figure 2-2	4
• Changed Table 3-1	6
• Changed Figure 3-2	8
• Changed Table 3-3	9
• Changed content in Section 3.5.2	12
• Added content to Section 3.8	13
• Changed Figure 4-4	18
• Added Section 6.4.1	39
• Added Section 6.8	44
• Added Section 6.10	46
• Added Section 6.11	47

IMPORTANT NOTICE AND DISCLAIMER

TI PROVIDES TECHNICAL AND RELIABILITY DATA (INCLUDING DATA SHEETS), DESIGN RESOURCES (INCLUDING REFERENCE DESIGNS), APPLICATION OR OTHER DESIGN ADVICE, WEB TOOLS, SAFETY INFORMATION, AND OTHER RESOURCES "AS IS" AND WITH ALL FAULTS, AND DISCLAIMS ALL WARRANTIES, EXPRESS AND IMPLIED, INCLUDING WITHOUT LIMITATION ANY IMPLIED WARRANTIES OF MERCHANTABILITY, FITNESS FOR A PARTICULAR PURPOSE OR NON-INFRINGEMENT OF THIRD PARTY INTELLECTUAL PROPERTY RIGHTS.

These resources are intended for skilled developers designing with TI products. You are solely responsible for (1) selecting the appropriate TI products for your application, (2) designing, validating and testing your application, and (3) ensuring your application meets applicable standards, and any other safety, security, regulatory or other requirements.

These resources are subject to change without notice. TI grants you permission to use these resources only for development of an application that uses the TI products described in the resource. Other reproduction and display of these resources is prohibited. No license is granted to any other TI intellectual property right or to any third party intellectual property right. TI disclaims responsibility for, and you will fully indemnify TI and its representatives against, any claims, damages, costs, losses, and liabilities arising out of your use of these resources.

TI's products are provided subject to [TI's Terms of Sale](#) or other applicable terms available either on ti.com or provided in conjunction with such TI products. TI's provision of these resources does not expand or otherwise alter TI's applicable warranties or warranty disclaimers for TI products.

TI objects to and rejects any additional or different terms you may have proposed.

Mailing Address: Texas Instruments, Post Office Box 655303, Dallas, Texas 75265
Copyright © 2022, Texas Instruments Incorporated