

LDC480 Series

480 W High Performance Ultracompact DIN Rail Power Supply

LDC480 Series is a single phase, ultra compact DIN Rail power supply with active PFC, ideal for many applications.

Its compact size, high efficiency, excellent reliability together with easy installation makes it ideal for various industrial applications.

LDC480 Series is Class I isolation device designed to be mounted on DIN rail and installed inside a protective enclosure.



FEATURES

- Input voltage 90 - 264 VAC or 110 - 345 VDC
- Output voltages 24 V, 36 V, 48 V, 72 V (adjustable)
- Operating ambient temperature range -40°C to +70°C (up to 60°C with no derating)
- Efficiency up to 94%
- Active PFC
- Overload 150%
- Constant Current or Hiccup mode limitation (user settable)
- Easy parallelable for power increase
- Extremely compact size in aluminum enclosure
- Dimensions: 56 x 140 x 117 mm



APPLICATIONS

- Industrial control equipment
- Communication
- Instrumentation equipment

1. MODEL SELECTION

MODEL	INPUT VOLTAGE RANGE	OUTPUT VOLTAGE	MAX OUTPUT CURRENT	EFFICIENCY	REDUNDANCY	MAX OUTPUT POWER
LDC480-24	120 - 240 VAC (110 - 345 VDC)	24 V	20 A	93 %		480 W
LDC480-24P	120 - 240 VAC (110 - 345 VDC)	24 V	20 A	93 %	Internal ORing diode	480 W
LDC480-36 ¹	120 - 240 VAC (110 - 345 VDC)	36 V	15 A	94 %		480 W
LDC480-36P ¹	120 - 240 VAC (110 - 345 VDC)	36 V	15 A	94 %	Internal ORing diode	480 W
LDC480-48	120 - 240 VAC (110 - 345 VDC)	48 V	10 A	94 %		480 W
LDC480-48P	120 - 240 VAC (110 - 345 VDC)	48 V	10 A	94 %	Internal ORing diode	480 W
LDC480-72	120 - 240 VAC (110 - 345 VDC)	72 V	6.7 A	94 %		480 W
LDC480-72P	120 - 240 VAC (110 - 345 VDC)	72 V	6.7 A	94 %	Internal ORing diode	480 W

¹ Not UL 508 certified

Discontinued models

2. INPUT SPECIFICATIONS

PARAMETER	DESCRIPTION / CONDITIONS	SPECIFICATION
AC Input Voltage	Nominal (UL certified) Range	100 - 240 VAC 90 - 264 VAC
DC Input Voltage		110 - 345 VDC
Input Frequency		47 - 63 Hz
AC Input Current	V _{in} = 120 VAC 24 V, 48 V & 72 V models 36 V models	4.8 A 5.5 A
	V _{in} = 240 VAC 24 V, 48 V & 72 V models 36 V models	2.4 A 1.9 A
DC Input Current	V _{in} = 110 VDC 24 V, 48 V & 72 V models 36 V models	4.9 A 5.3 A
	V _{in} = 345 VDC 24 V, 48 V & 72 V models 36 V models	1.7 A 1.9 A
Power Factor Correction	Active	> 0.9
Inrush Peak Current I _{pt}	Peak Current measured after 0.2 ms from main connection; 240 VAC / 50 Hz; T _a = 25°C; Cold Start	≤ 23 A 0.56 A ² s
Touch (Leakage) Current		≤ 0.9 mA
Internal Protection Fuse	Not user replaceable	8 AT
Recommended External Protection	It is strongly recommended to provide external surge arresters (SPD) according to local regulations.	Fuse 10 AT or MCB 10 A C curve

3. OUTPUT SPECIFICATIONS

PARAMETER	DESCRIPTION / CONDITIONS	SPECIFICATION
Output Voltage (Adjustable)	24 V models	22 - 29 VDC
	36 V models	32 - 40 VDC
	48 V models	45 - 55 VDC
	72 V models	70 - 85 VDC
Output Current (Continuous)	24 V models	20 A
	36 V models	15 A
	48 V models	10 A
	72 V models	6.7 A
Load Regulation	24 V & 36 V models	≤ 1.5 %
	48 V & 72 V models	≤ 0.5 %
Ripple & Noise ²	24 V models	≤ 150 mVpp
	36 V models	≤ 150 mVpp
	48 V models	≤ 200 mVpp
	72 V models	≤ 350 mVpp
Hold-up Time		≥ 25 ms
Status Signals	DC OK - green LED OVERLOAD - red LED DC OK - dry contact (NO, 24 VDC / 1 A)	
Parallel Connection ³	Possible for power or redundancy (with external ORing module) P models - include internal ORing diode	

² Ripple and Noise are measured with 20 MHz bandwidth, probe terminated with a 0.1 μF MKP parallel capacitor.

³ Pay attention, set the current limitation mode jumper on C.C. mode when connecting more units in parallel.

4. PROTECTIONS

PARAMETER	DESCRIPTION / CONDITIONS	SPECIFICATION	
Short Circuit Protection	Constant current or Hiccup mode (user settable)		
Overload Protection	Constant current Overload Limit (user settable)	24 V models	21 A
		36 V models	16 A
		48 V models	12 A
		72 V models	7 A
	Hiccup mode Overload Limit (max. 5 s) (user settable)	24 V models	30 A
		36 V models	20 A
	48 V models	17 A	
	72 V models	12 A	
Thermal Protection			
Input Under Voltage Lockout			
Over Voltage Protection	24 V models	≥ 33 VDC	
	36 V models	≥ 45 VDC	
	48 V models	≥ 68 VDC	
	72 V models	≥ 100 VDC	

5. ENVIRONMENTAL, EMC & SAFETY SPECIFICATIONS

PARAMETER	DESCRIPTION / CONDITIONS	SPECIFICATION
Operating Temperature	UL certified up to 50°C at 120 VAC or up to 60°C at 240 VAC Start-up type tested: - 40°C, possible at Vnom with load deration.	-40 to +70 °C
Storage Temperature		-40 to +80 °C
Derating	Over 50°C at 120 VAC Over 60°C at 240 VAC	- 7.6 W/°C - 7.2 W/°C
Dissipated Power	24 V models 36 V models 48 & 72 V models	< 36.5 W < 32.5 W < 31 W
Humidity	Non-condescending	5 - 95 % RH
Life Time Expectancy	Ta = 25°C, full load	167 953 (19.1) hrs (years)
MTBF	MIL-HDBK-217F at Ta = 25°C, full load	> 600 000 hrs
Overvoltage Category	EN 50178	III
Pollution Degree	IEC 60664-1	2
Protection Class	Class I	
Isolation	Input to Output Input to Ground Output to Ground	4.2 kVDC 2.2 kVDC 0.75 kVDC
Safety Standards & Approvals	UL 508 IEC/EN 61010-1 IEC/EN 61010-2-201 IEC/EN 60950	
EMC Emissions	EN 55011 / CISPR 11 EN 61000-3-2	Class B Class A
EMC Immunity	EN 61000-4-2 EN 61000-4-3 EN 61000-4-4 EN 61000-4-5 EN 61000-4-11	Level 3 Level 3 Level 4 Level 4 Level 2
Protection Degree	EN 60529	IP20
Vibration Sinusoidal	IEC 60068-2-6	5 - 17.8 Hz: ±1.6 mm; 17.8 - 500 Hz: 2 g 2 hours / axis (X,Y, Z)
Shock	IEC 60068-2-27	30 g 6 ms, 20 g 11 ms; 3 bumps / direction, 18 bumps total

6. MECHANICAL SPECIFICATIONS

PARAMETER	DESCRIPTION / CONDITIONS	SPECIFICATION
Dimensions		56 x 140 x 117 mm 2.2 x 5.5 x 4.6 in
Weight		1100 g
Mounting Rail	IEC 60715/H15/TH35-7.5(-15)	
Connection Terminals	Screw type pluggable (24 - 12 AWG)	2.5 mm ²
Case Material	Aluminum	

7. PIN LAYOUT & DESCRIPTION

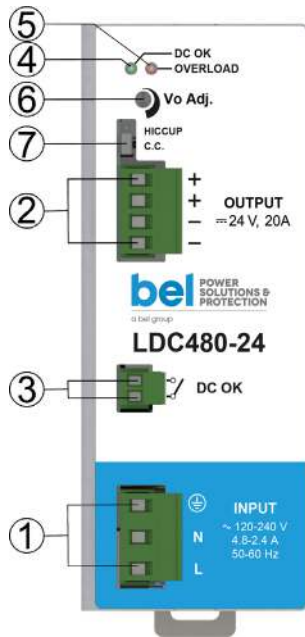

PIN	DESCRIPTION
1	AC/DC input
2	DC output (load)
3	Diagnostic Output (dry contact, NC output OK)
4	Green LED: Output OK
5	Red LED: Overload
6	Output voltage adjustment
7	Selectable limitation mode (Hiccup mode, C.C. mode)

INPUT CONNECTION	Single phase	DC Input
	L = Line	L =+ Positive DC
	N = Neutral	N = - Negative DC
	⊕ = Earth ground	⊕ = Earth ground

OUTPUT CONNECTION	
	+ = Positive DC
	- = Negative DC

SIGNALLING	
	DC OK: dry contact
	• NO
	• COM

8. MECHANICAL DRAWING

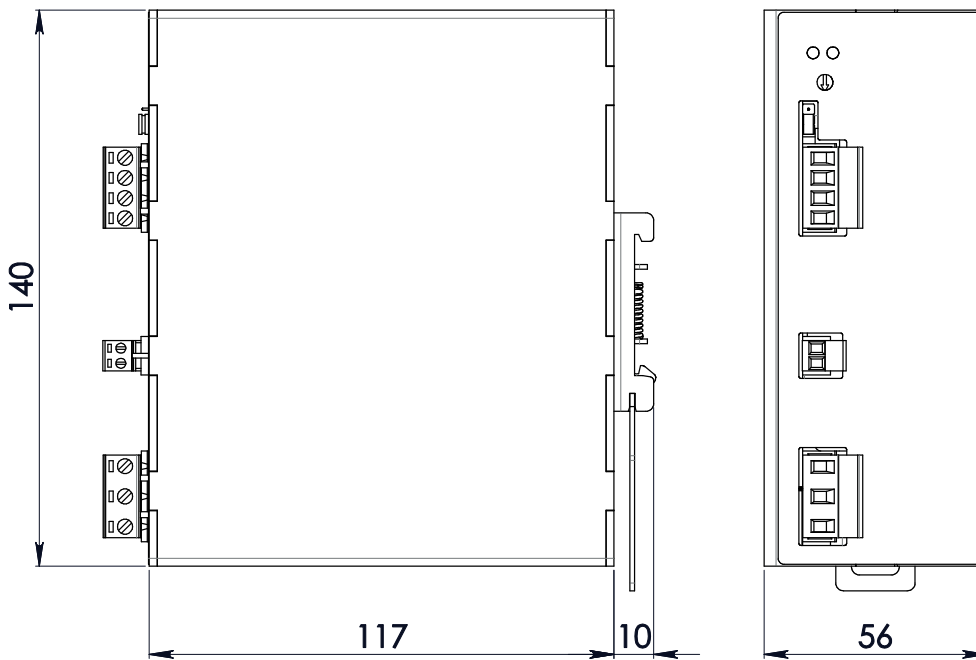

Figure 1. Mechanical Drawing

Notes:

Technical parameters are typical, measured in laboratory environment at 25°C and 240 VAC / 50 Hz, at nominal values, after minimum 5 minutes of operation. Power rating, losses, efficiency, ripple, thermal behaviour and start-up may change outside of the nominal rated input range. Contact factory for details.

NUCLEAR AND MEDICAL APPLICATIONS - Products are not designed or intended for use as critical components in life support systems, equipment used in hazardous environments, or nuclear control systems.

TECHNICAL REVISIONS - The appearance of products, including safety agency certifications pictured on labels, may change depending on the date manufactured. Specifications are subject to change without notice.



Asia-Pacific +86 755 298 85888 EMEA +353 61 49 8941 North America +1 866 513 2839

belfuse.com/power-solutions