

THIS DRAWING IS UNPUBLISHED. RELEASED FOR PUBLICATION
 © COPYRIGHT - By - ALL RIGHTS RESERVED.

LOC	DIST	REVISIONS					
		P	LTR	DESCRIPTION	DATE	DWN	APVD
AF	50		J3	REVISED PER ECR-18-014081	21SEP2018	BDA	SV

- 1 CONTINUOUS STRIP ON REELS WITH TERMINALS LOCATED ON 5.59 [.220] CENTERS.
- 2 SLOT ACCEPTS 0.25-0.36mm [#30-#27] AWG COPPER MAGNET WIRE.
SLOT ACCEPTS 0.32-0.45mm [#28-#25] AWG ALUMINUM MAGNET WIRE.
ALUMINUM WIRE RANGE APPLIES FOR POST-TIN PLATED VERSIONS ONLY.
- 3 MATES WITH STANDARD MAG-MATE STYLED POKE-IN TAB TERMINAL.
- 4 TIN PLATE

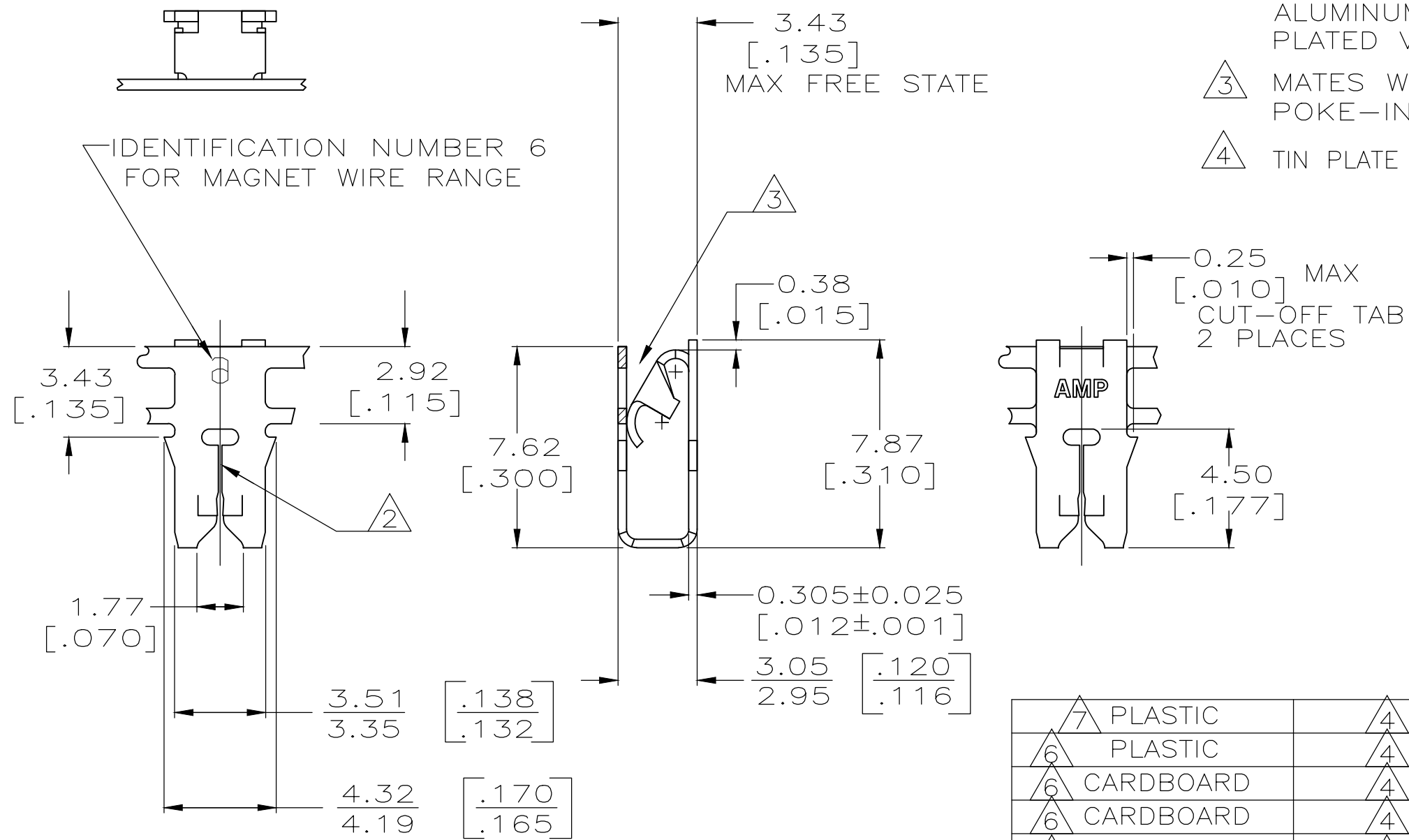

IDENTIFICATION NUMBER 6 FOR MAGNET WIRE RANGE

REELING	FINISH	MATERIAL	PART NO
7	4	H04 PHOS. BRONZE	63590-5
6	4	H04 PHOS. BRONZE	63590-4
6	4	H04 PHOS. BRONZE	63590-3
6	4	4M BRASS	63590-2
6	4	4M BRASS	63590-1

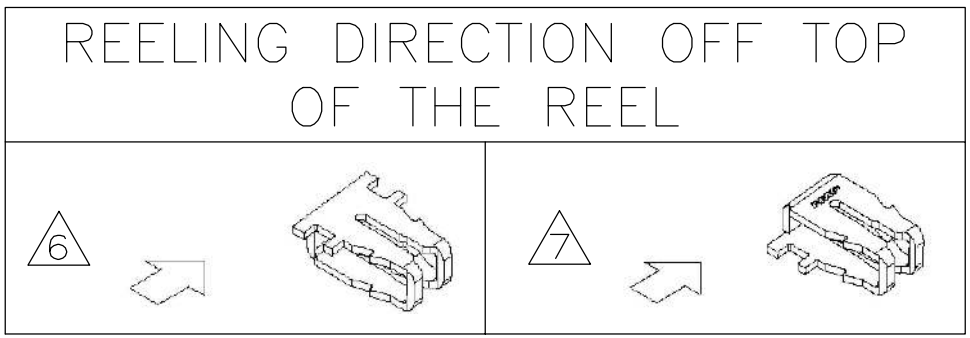

THIS DRAWING IS A CONTROLLED DOCUMENT.

DIMENSIONS: MM [INCHES]	TOLERANCES UNLESS OTHERWISE SPECIFIED: 0 PLC ± - 1 PLC ± - 2 PLC ± 0.25 [.010] 3 PLC ± - 4 PLC ± - ANGLES ± -	DWN 7/30/90 MICHAEL S. FEHER CHK 7/30/90 JEFF R. RUTH APVD 7/30/90 DONALD F. DECKER	TE Connectivity	
MATERIAL: SEE TABLE	FINISH: SEE TABLE	PRODUCT SPEC: 108-2012	NAME: SPECIAL LEAF CONTACT, 300 SERIES MAG-MATE	
		APPLICATION SPEC: 114-2046	SIZE: A3	CAGE CODE: 00779
		WEIGHT: -	DRAWING NO: C-63590	RESTRICTED TO: -
CUSTOMER DRAWING			SCALE: 5:1	SHEET: 1 OF 1
			REV: J3	