



## Product Brief

# XMC4800 Automation Board V2

Explore XMC4800 microcontroller based on ARM® Cortex®-M4

The XMC4800 Automation Board V2 utilizes Infineon's industry leading XMC ARM® Cortex®-M4 microcontroller in combination with Infineon supply, interface, communication and safety products. The XMC4800 Automation Board V2 is designed to evaluate the capabilities of the XMC4800 microcontroller especially in EtherCAT® slave applications and can be used with a wide range of development tools including Infineon's free of charge Eclipse based IDE, DAVE™.

### PCB of the Automation Board V2

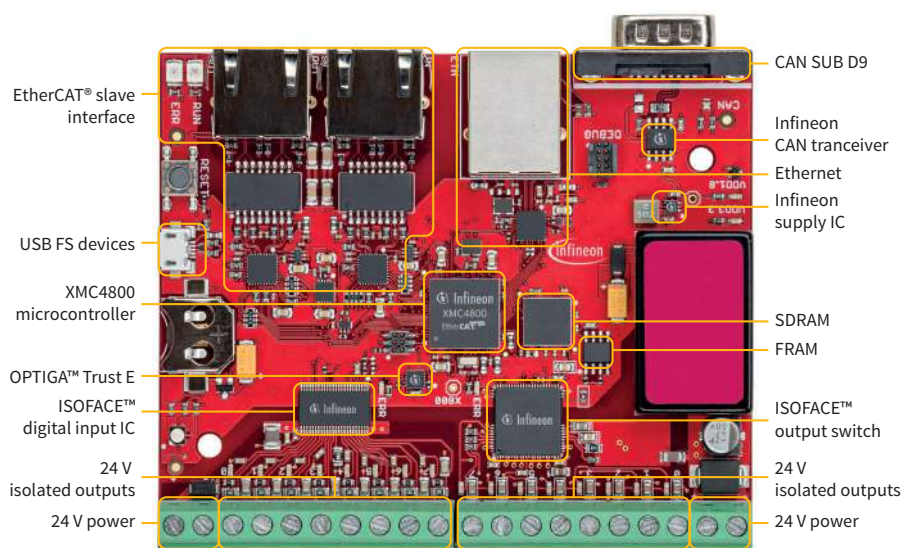

### Key features

- > XMC4800-E196 MCU based on ARM® Cortex®-M4 at 144 MHz
- > EtherCAT® slave controller, 2 MB flash and 352 KB RAM
- > OPTIGA™ Trust E embedded security solution (CC EAL6+)
- > Real time clock crystal
- > SPI FRAM (64 kB non-volatile memory)
- > EtherCAT® slave node (2 EtherCAT® PHY and RJ45 Jacks)
- > 24 V ISOFACE™ 8-channel inputs and 8-channel outputs CAN transceiver
- > CAN transceiver

### Key benefits

- > Complete Automation kit gateway
- > Combined MCU with EtherCAT slave application
- > Isolated interfaces w/ diagnose
- > Ethernet connectivity with software examples available
- > 24 V Supply
- > CAN connectivity
- > Full software DAVE™ examples

### Key applications

- > Commercial, Construction and Agricultural Vehicles (CAV)
- > Building and automation
- > Industrial
- > Micro PLC
- > Motor control and drives

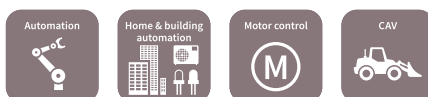

# XMC4800 Automation Board V2

Explore XMC4800 microcontroller based on ARM® Cortex®-M4

## Block diagram

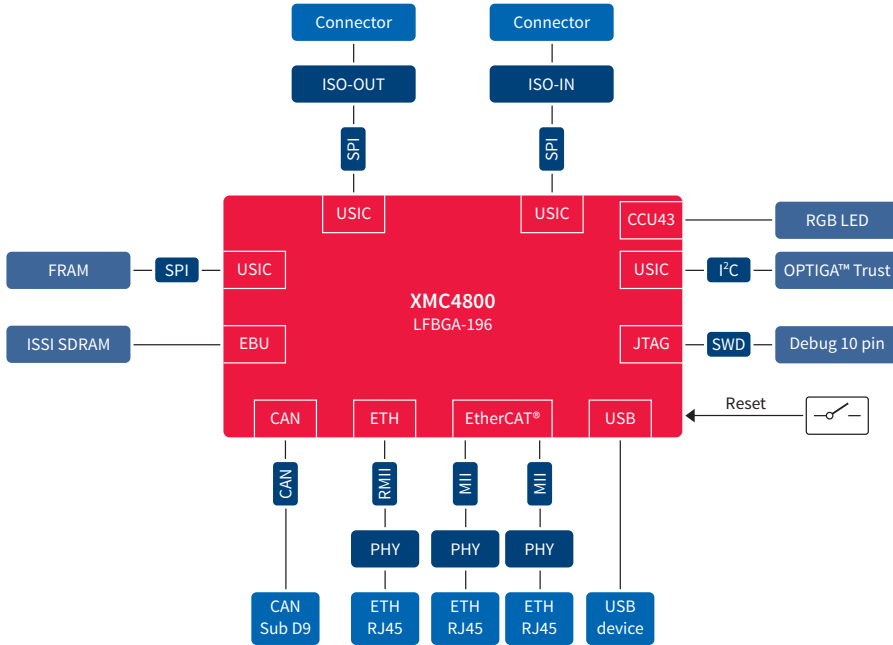

The block diagram shows the main components of the XMC4800 Automation Board V2 and their interconnections.

The main building blocks are:

- > XM4800 microcontroller in a LFBGA-196 package
- > 2 EtherCAT® PHY with 2 RJ45 plugs
- > 1 Ethernet PHY with RJ45 plug
- > 24 V ISOFACE™ 8-channel inputs and 8-channel outputs
- > RGB LED, CAN RG LED, reset push-button
- > Micro-AB USB plug
- > CAN transceiver with SUB 9 connector

## Product table

Type	Description	Ordering code
KIT_XMC48_AUT_BASE_V2	The XMC4800 Automation Board V2 utilizes Infineon's industry leading XMC ARM® Cortex®-M4 microcontroller in combination with Infineon supply, interface/communication and safety products.	KITXMC48AUTBASEV2TOB01
XMC4800-E196K2048	ARM® Cortex®-M4 microcontroller	XMC4800E196K2048AAXQMA1
ISO2H823V2.5	24 V 8-channel isolated output	ISO2H823V25XUMA1
ISO1I813T	24 V 8-channel isolated input	ISO1I813TXUMA1
SLS32AIA020A4 USON10	OPTIGA™ Trust E – embedded security solution	SLS32AIA020A4USON10XTMA2
TLE6250GV33	Infineon CAN transceiver	TLE6250GV33XUMA1
IFX54441LDV	Infineon voltage regulator	IFX54441LDVXUMA1

Published by  
Infineon Technologies AG  
81726 Munich, Germany

© 2017 Infineon Technologies AG.  
All Rights Reserved.

### Please note!

THIS DOCUMENT IS FOR INFORMATION PURPOSES ONLY AND ANY INFORMATION GIVEN HEREIN SHALL IN NO EVENT BE REGARDED AS A WARRANTY, GUARANTEE OR DESCRIPTION OF ANY FUNCTIONALITY, CONDITIONS AND/OR QUALITY OF OUR PRODUCTS OR ANY SUITABILITY FOR A PARTICULAR PURPOSE. WITH REGARD TO THE TECHNICAL SPECIFICATIONS OF OUR PRODUCTS, WE KINDLY ASK YOU TO REFER TO THE RELEVANT PRODUCT DATA SHEETS PROVIDED BY US. OUR CUSTOMERS AND THEIR TECHNICAL DEPARTMENTS ARE REQUIRED TO EVALUATE THE SUITABILITY OF OUR PRODUCTS FOR THE INTENDED APPLICATION.

WE RESERVE THE RIGHT TO CHANGE THIS DOCUMENT AND/OR THE INFORMATION GIVEN HEREIN AT ANY TIME.

### Additional information

For further information on technologies, our products, the application of our products, delivery terms and conditions and/or prices, please contact your nearest Infineon Technologies office ([www.infineon.com](http://www.infineon.com)).

### Warnings

Due to technical requirements, our products may contain dangerous substances. For information on the types in question, please contact your nearest Infineon Technologies office.

Except as otherwise explicitly approved by us in a written document signed by authorized representatives of Infineon Technologies, our products may not be used in any life-endangering applications, including but not limited to medical, nuclear, military, life-critical or any other applications where a failure of the product or any consequences of the use thereof can result in personal injury.