

LOC	DIST	REV	DESCRIPTION	DATE	DMN	APVD
ES	00					
		K	REVISED PER ECO-12-013119	16JUL2012	AZ	AC
		K1	REVISED PER ECO-16-011108	26JUL2016	PP	SH
		L	REVISED PER ECO-17-017667	05DEC2017	IT	SH

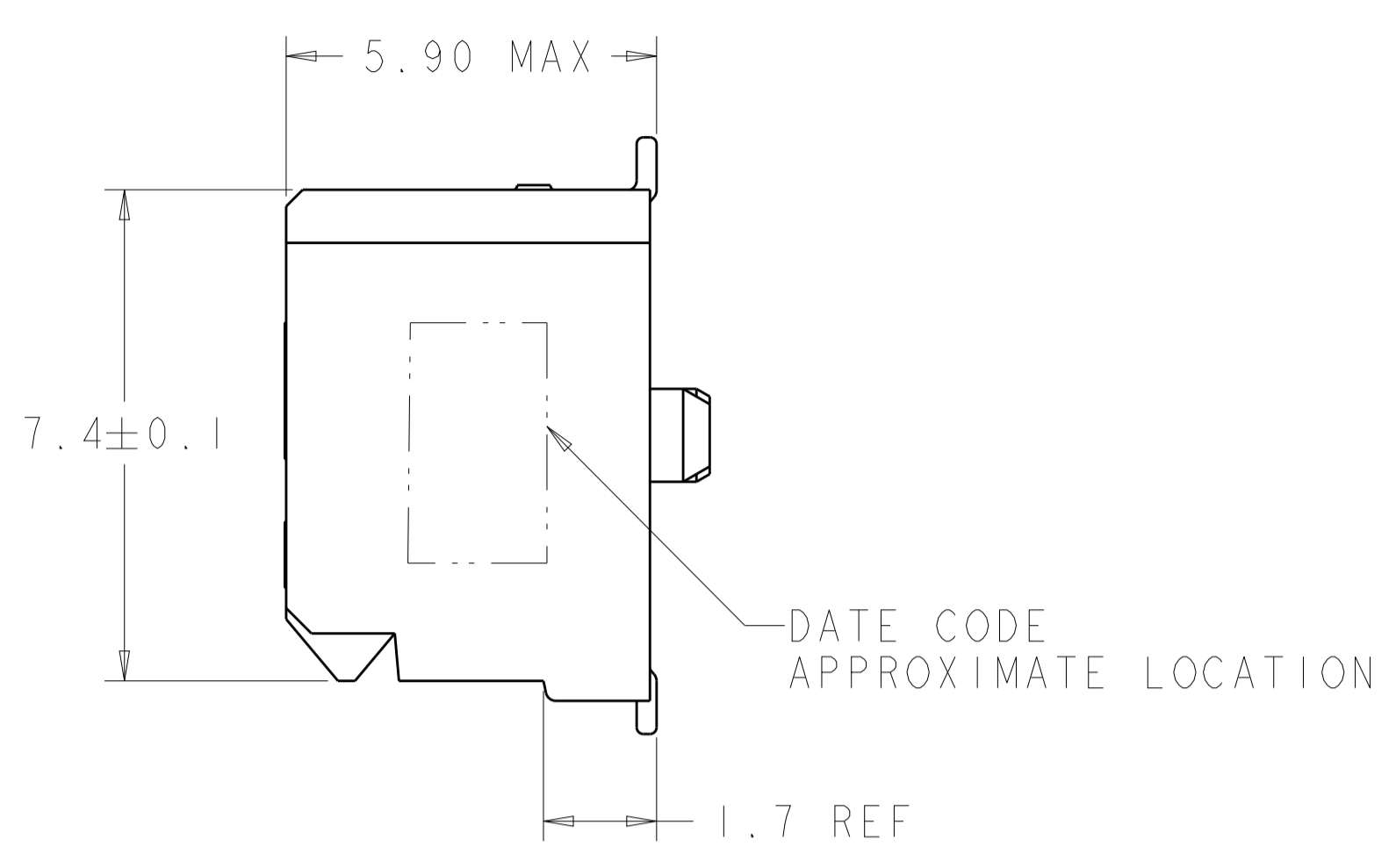

1. PART COMPATIBLE WITH XFP MSA. REFER TO THE XFP MSA FOR DIMENSIONS NOT SHOWN ON THIS PRINT.
- △ HOUSING MATERIAL: HIGH TEMPERATURE LCP, UL 94V-0 COLOR WHITE
CONTACT MATERIAL: PHOSPHOR BRONZE
- △ CONTACTS: 0.00076 MIN GOLD IN CONTACT AREA, 0.00013 MIN GOLD ON SOLDER AREA, OVER 0.00127 MIN NICKEL UNDERPLATE ON ENTIRE CONTACT. LUBRICANT ON GOLD PLATE CONTACT AREAS.
4. PACKAGED 480 PIECES PER REEL
- △ GROUND, POWER, AND SIGNAL PAD ARRANGEMENT TO BE DETERMINED BY CUSTOMER
- △ DATUMS AND BASIC DIMENSIONS TO BE ESTABLISHED BY CUSTOMER
- △ SOLDER MASK KEEP OUT AREA.
- △ PULL GROOVES PERMITTED ON THESE SURFACES AT MOLDING ENGINEERING DISCRETION
- △ THE WIDTH OF TAPE REEL IS 24.00MM.
- △ THE WIDTH OF TAPE REEL IS 32.00MM

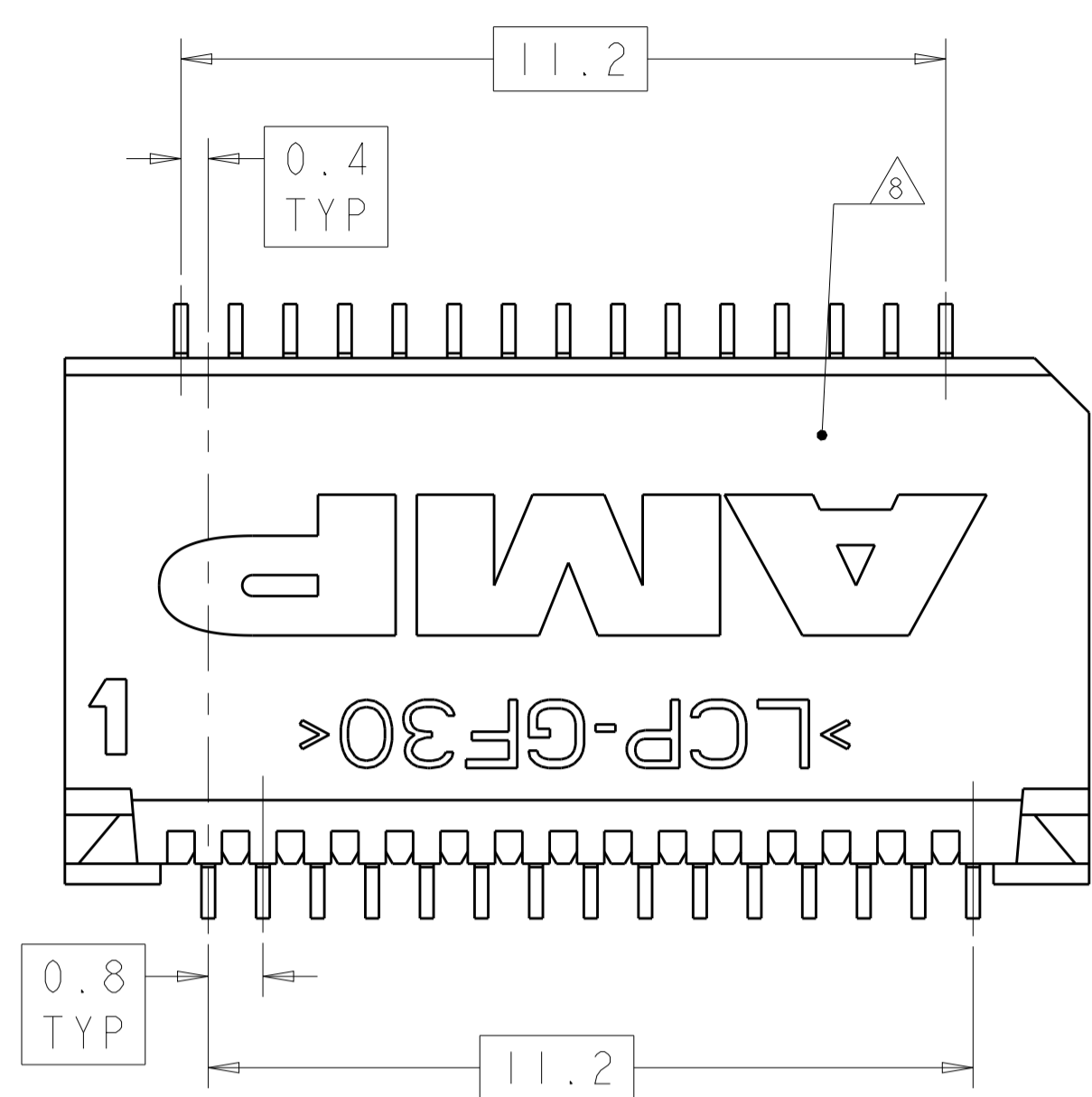
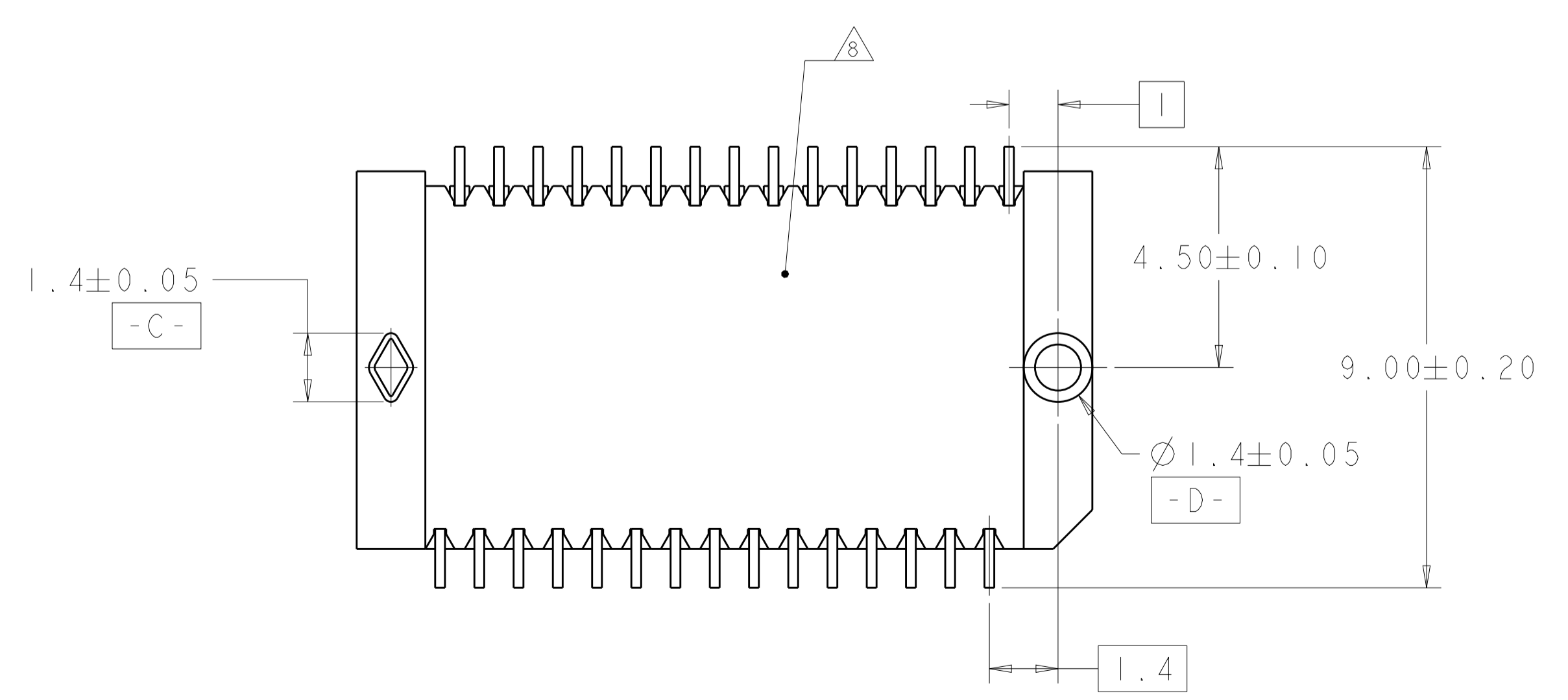
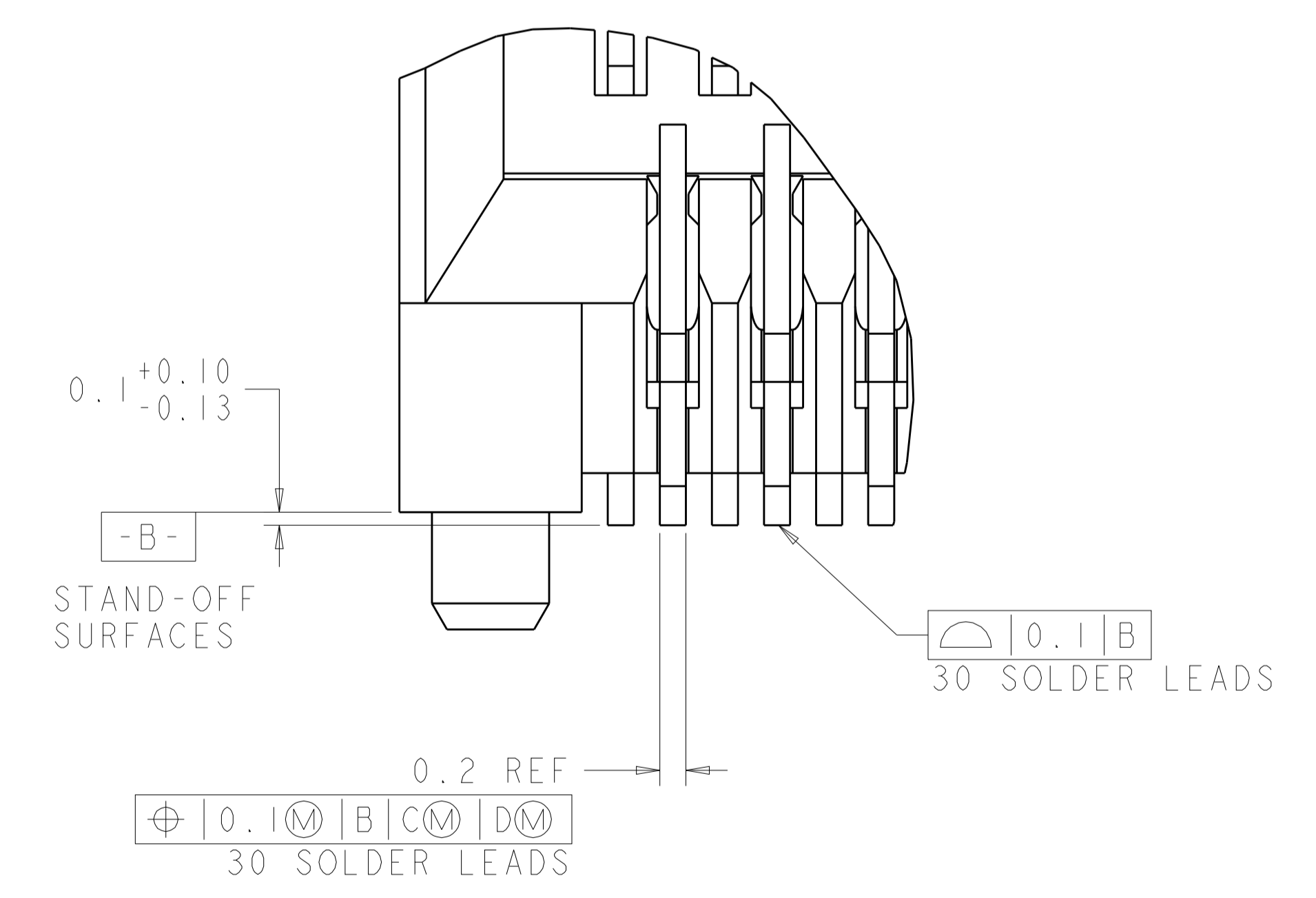
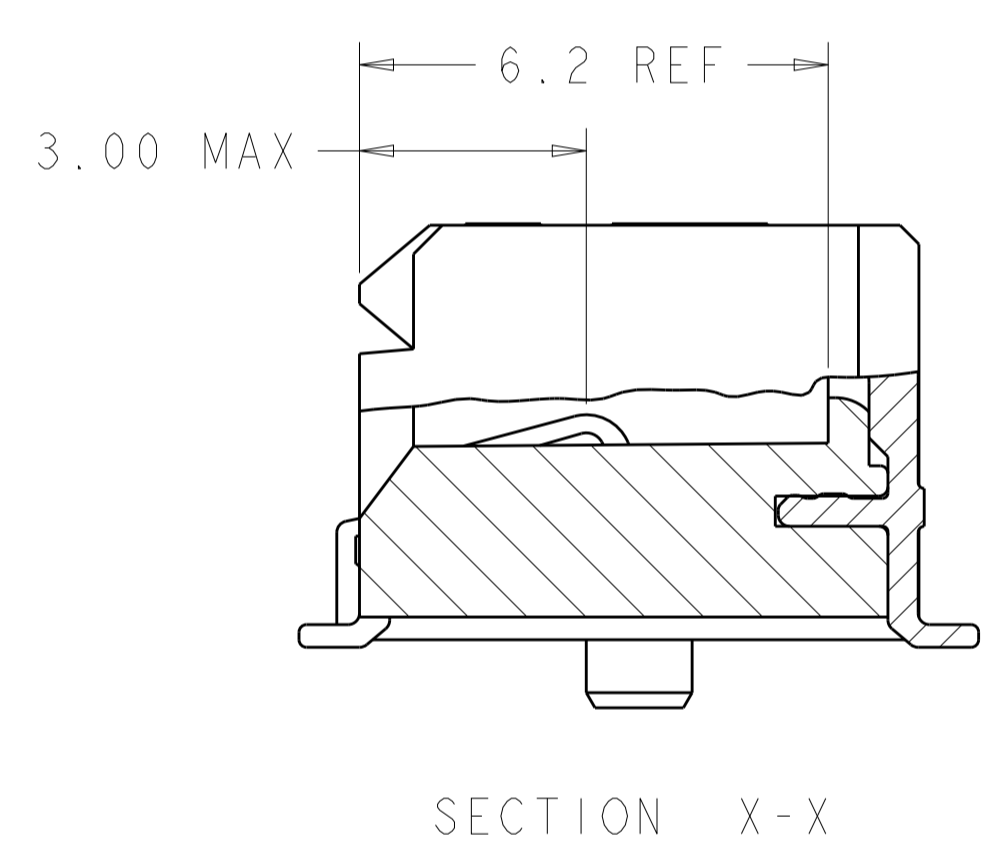
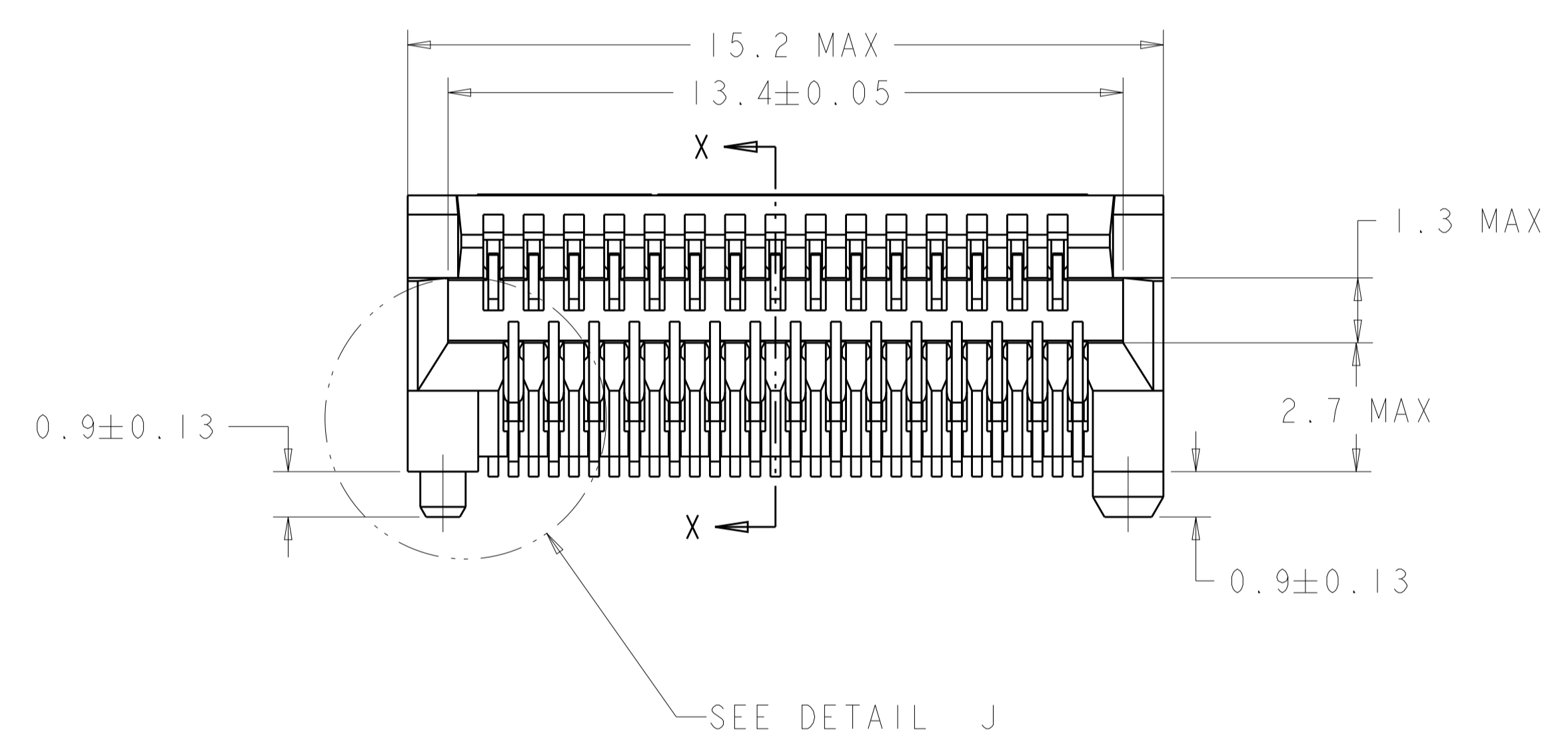

DETAIL J
SCALE 25:1

△8	YES	1367500-3
△9	YES	1367500-2
△9	NO	1367500-1
	DATE CODE	PART NUMBER

DIMENSIONS: mm 0 PLC ± 1 PLC ±0.10 2 PLC ± 3 PLC ± 4 PLC ± ANGLES ± FINISH		TOLERANCES UNLESS OTHERWISE SPECIFIED: 0 PLC ± 1 PLC ±0.10 2 PLC ± 3 PLC ± 4 PLC ± ANGLES ± FINISH		DMN P. KERLIN 17JAN03 CHK J. KOPPENHEFFER 06OCT03 APVD M. WALMSLEY 06OCT03 PRODUCT SPEC 108-1949 APPLICATION SPEC 114-13017 WEIGHT CUSTOMER DRAWING		Tyco Electronics Corporation Shanghai, P.R. China, 200233 NAME PT CONNECTOR ASSEMBLY, ENHANCED PERFORMANCE, 30 POSITION XFP, RTANG, 0.8MM PITCH SIZE CAGE CODE DRAWING NO RESTRICTED TO A100779C=1367500 SCALE 10:1 SHEET 1 OF 3 REV L	
---	--	---	--	---	--	---	--

LOC	DIST	REV	DATE	BY	APPV
ES	00				

REVISIONS			
REV	DATE	BY	APPV
-	-	-	-
-	-	-	-

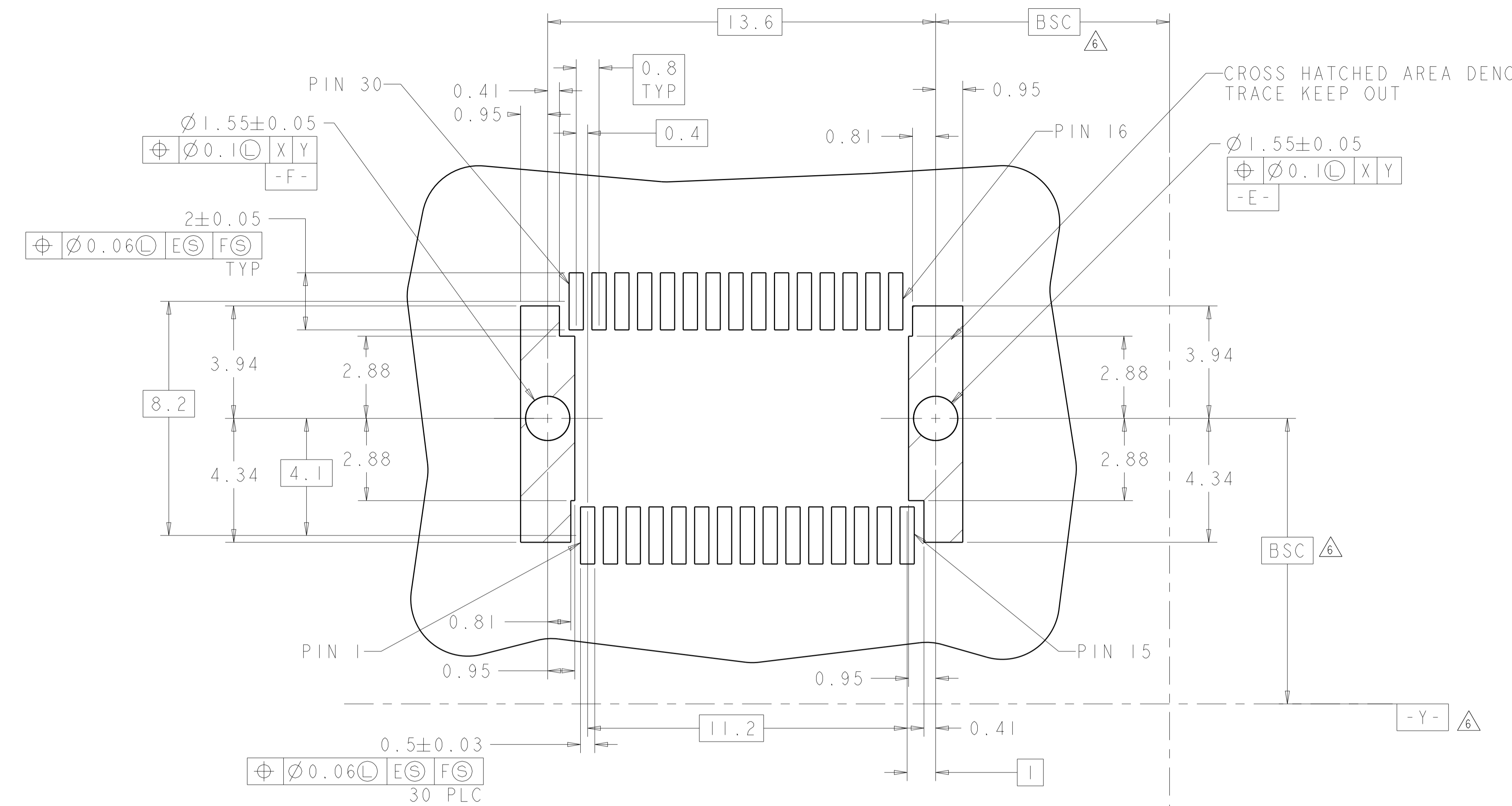

RECOMMENDED PCB CONFIGURATION

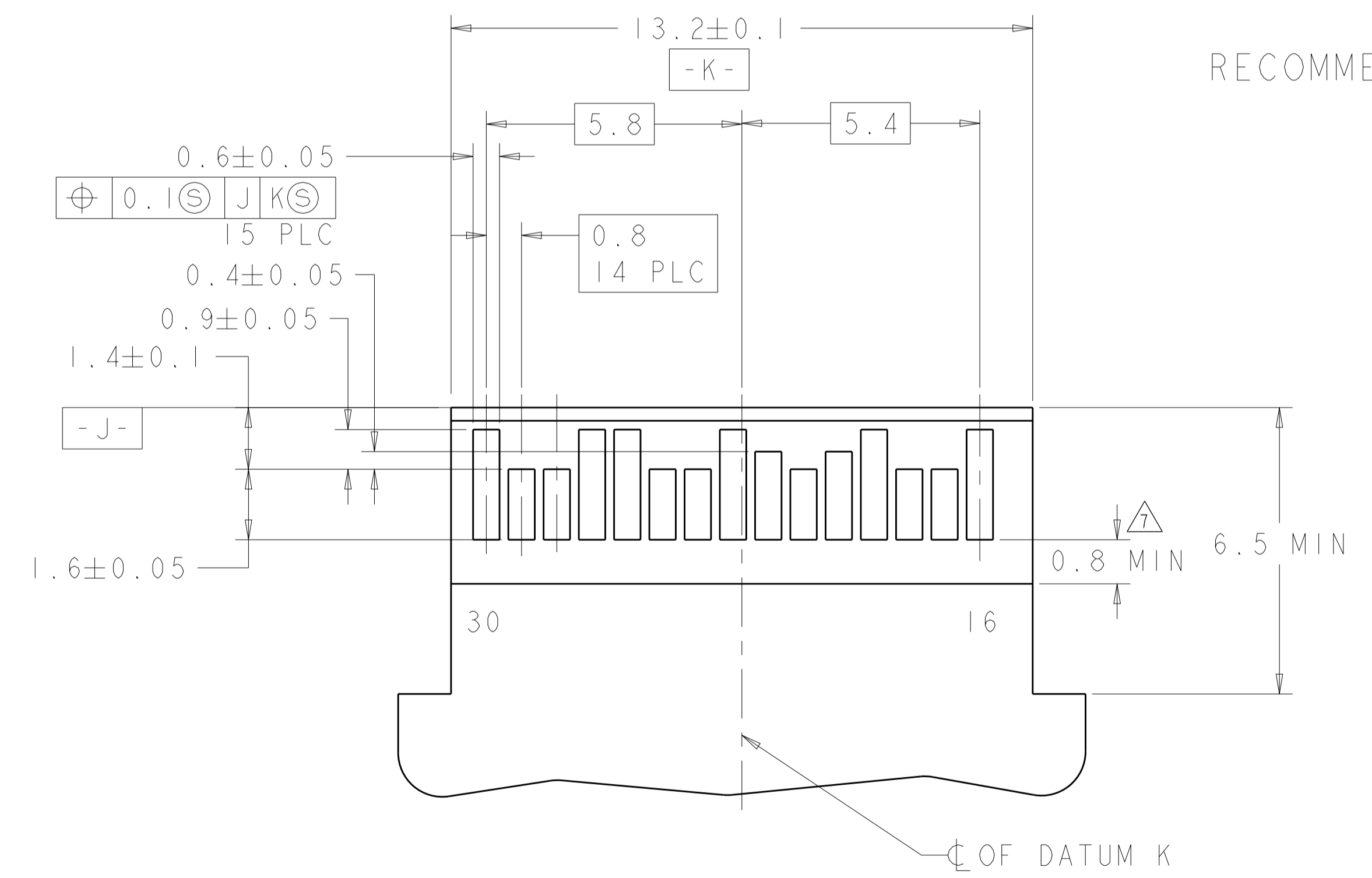

TOP VIEW

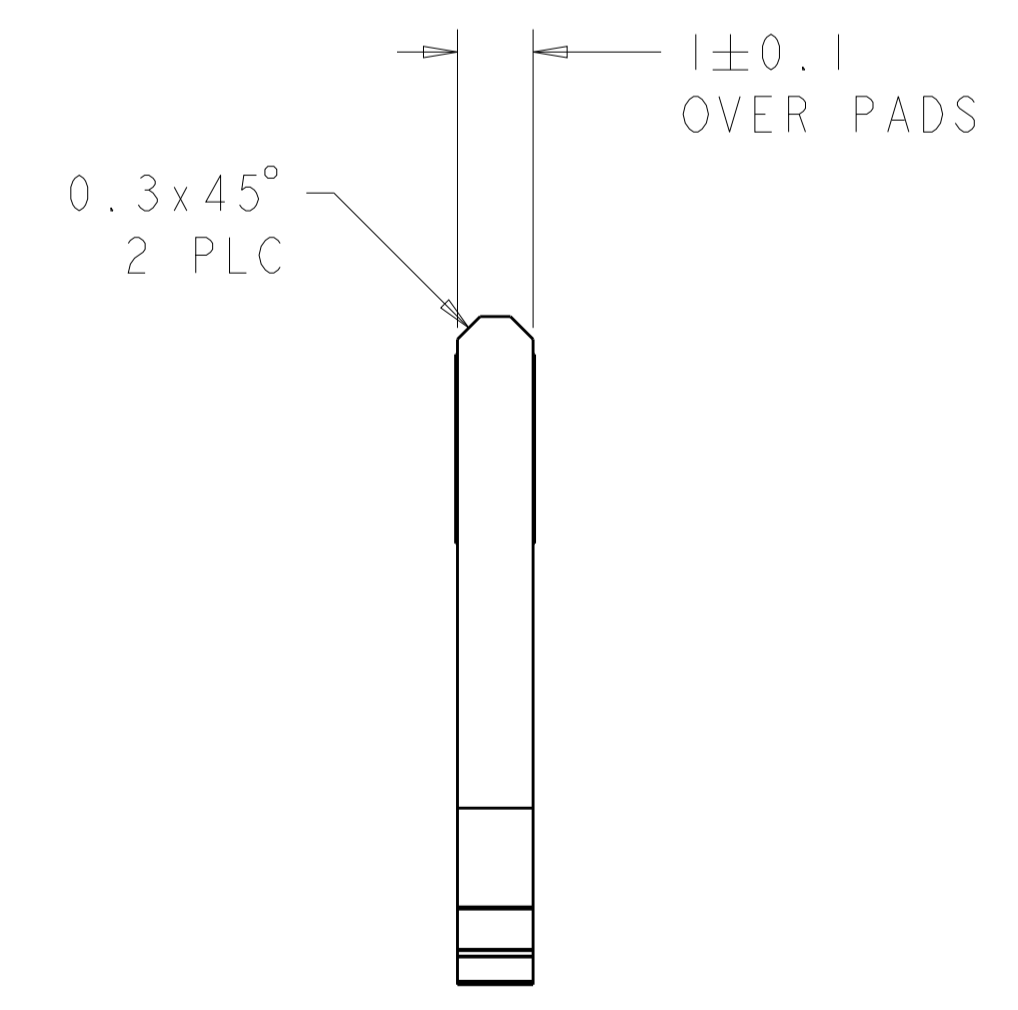

RECOMMENDED MATING PCB CONFIGURATION

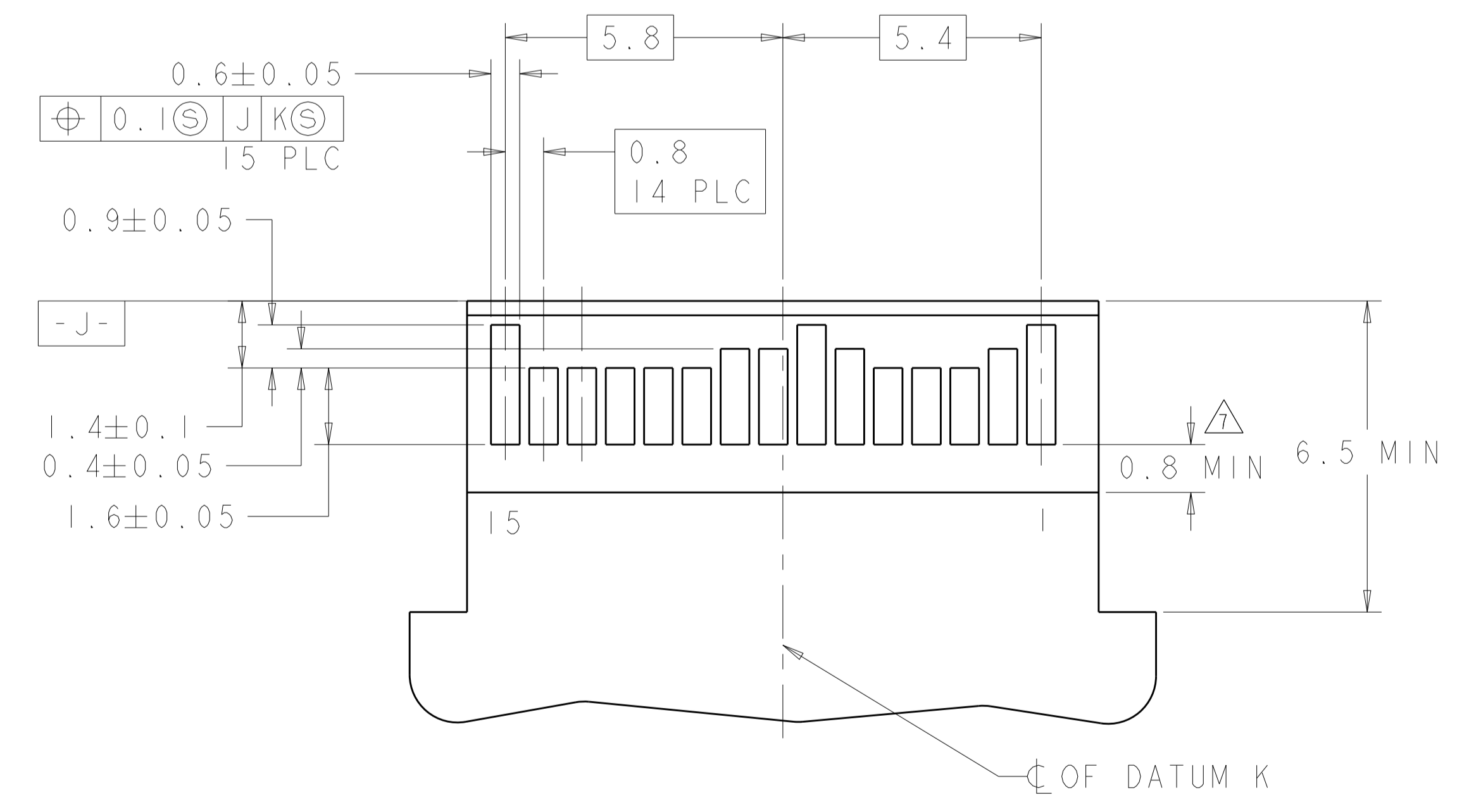

BOTTOM VIEW

DIMENSIONS: mm 		TOLERANCES UNLESS OTHERWISE SPECIFIED: 0 PLC ± 1 PLC ±0.10 2 PLC ± 3 PLC ± 4 PLC ± ANGLES ±		DWN P. KERLIN 17JAN03 CHK J. KOPPENHEFFER 06OCT03 APVD M. WALMSLEY 06OCT03 PRODUCT SPEC 108-1949 APPLICATION SPEC 114-13017 WEIGHT CUSTOMER DRAWING		Tyco Electronics Corporation Shanghai, P.R. China, 200233 NAME PT CONNECTOR ASSEMBLY, ENHANCED PERFORMANCE, 30 POSITION XFP, RTANG, 0.8MM PITCH SIZE CAGE CODE DRAWING NO RESTRICTED TO A100779C=1367500 SCALE 10:1 SHEET 2 OF 3 REV L	
-----------------------	--	---	--	---	--	---	--

LOC	DIST	REV	DATE	BY	APPV
ES	00				

REVISIONS			
NO.	DESCRIPTION	DATE	BY
-	SEE SHEET 1	-	-

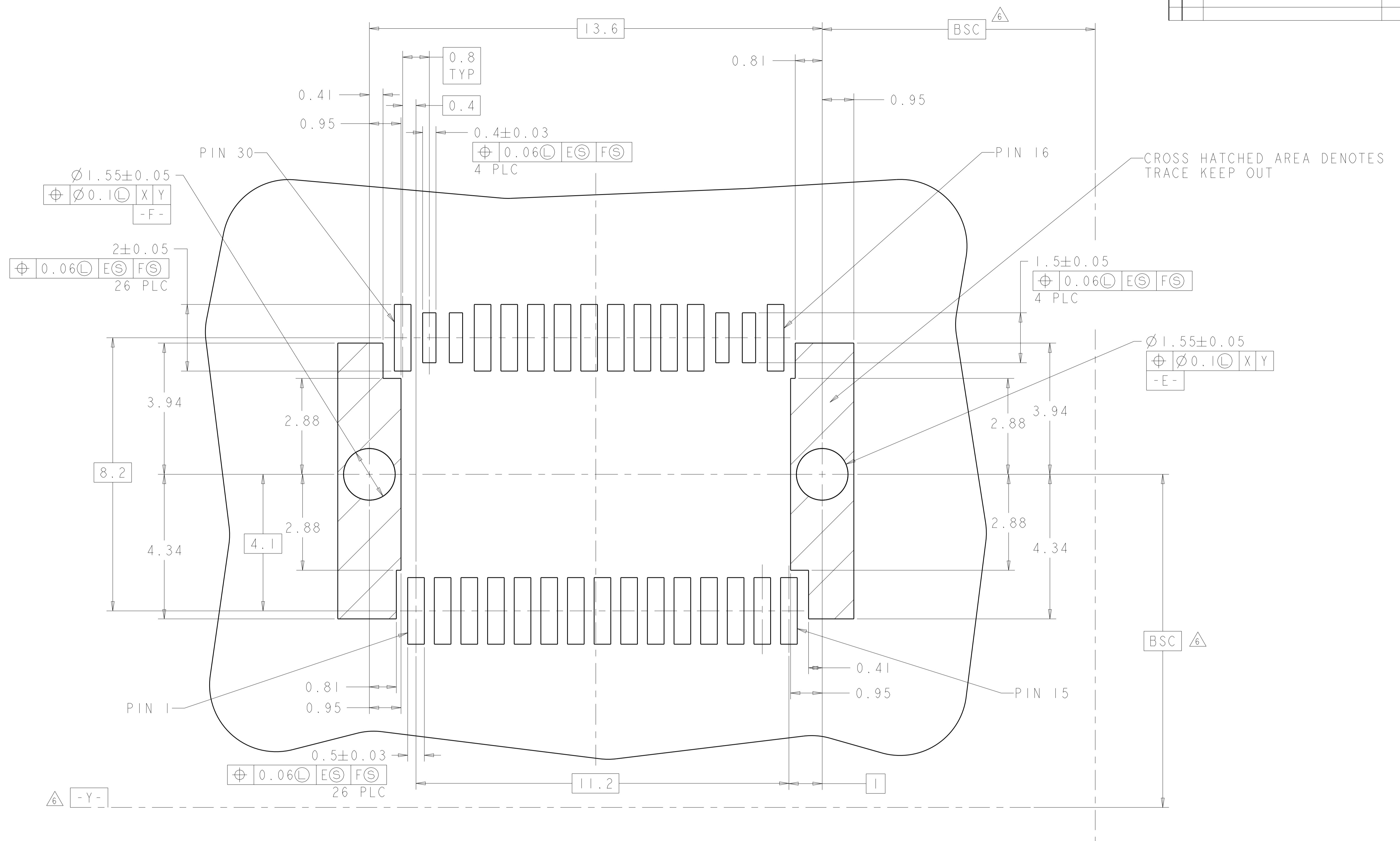

OPTIONAL LAYOUT FOR IMPROVED
 SIGNAL INTEGRITY, MOUNTING SIDE
 SCALE 16:1

<small>THIS DRAWING IS UNPUBLISHED. IT IS THE PROPERTY OF TYCO ELECTRONICS CORPORATION. IT IS SUBJECT TO CHANGE AND WITHOUT WARRANTY OF ANY KIND. THE USER SHALL BE RESPONSIBLE FOR THE LATEST REVISION.</small>		DWN P. KERLIN 17JAN03 CHK J. KOPPENHEFFER 06OCT03 APVD M. WALMSLEY 06OCT03	Tyco Electronics Corporation Shanghai, P.R. China, 200233
DIMENSIONS: mm 	TOLERANCES UNLESS OTHERWISE SPECIFIED: 0 PLC ± 1 PLC ±0.10 2 PLC ± 3 PLC ± 4 PLC ± ANGLES ±	NAME PT CONNECTOR ASSEMBLY, ENHANCED PERFORMANCE, 30 POSITION XFP, RTANG, 0.8MM PITCH PRODUCT SPEC 108-1949 APPLICATION SPEC 114-13017 WEIGHT CUSTOMER DRAWING	SIZE CAGE CODE DRAWING NO. RESTRICTED TO A 100779 C=1367500 SCALE 10:1 SHEET 3 OF 3 REV L