

REVISIONS			
REV	DESCRIPTION, ECN, EAR NO.	DATE	APP'D
A	PROPOSAL PER EAR# RJ19028	FEB26/19	L.CHAN
B	FIX THE ERROR FOR VIEW	JUN30/20	L.CHAN

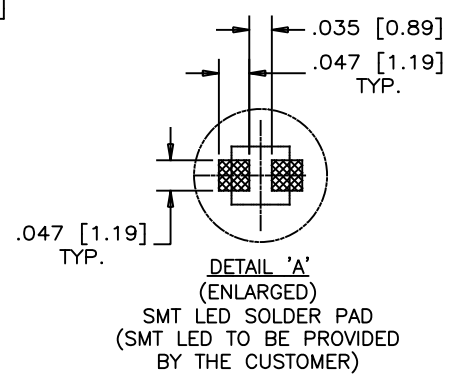
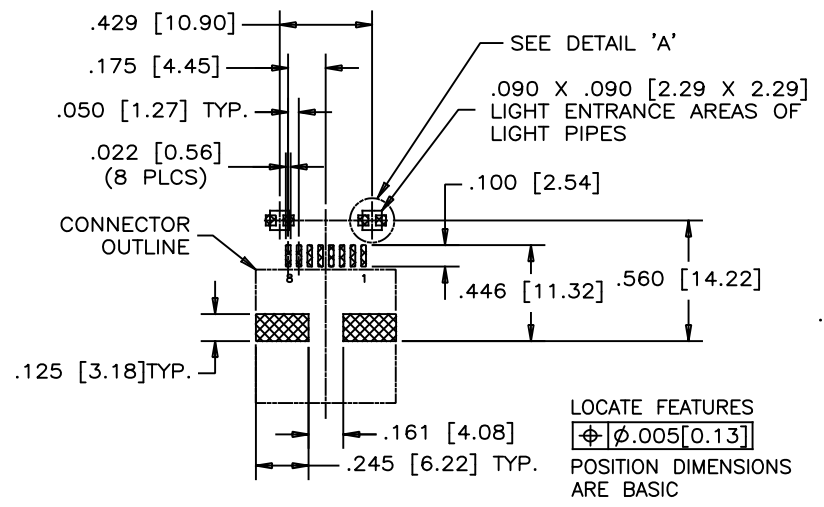
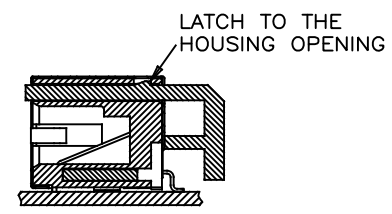
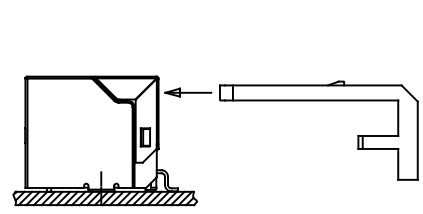
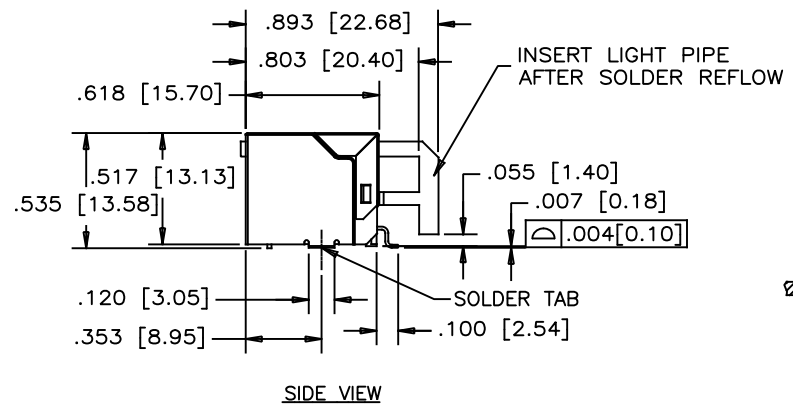
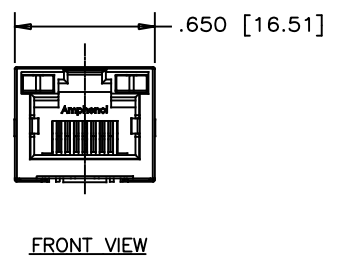
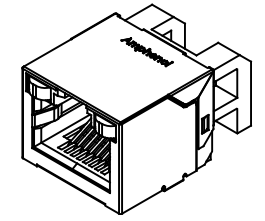
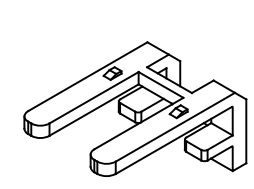
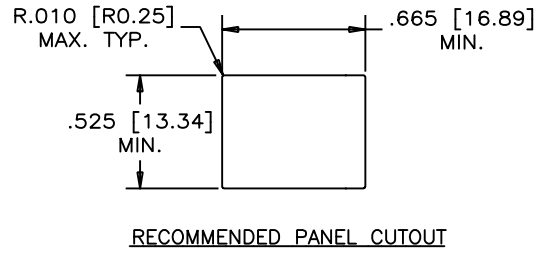
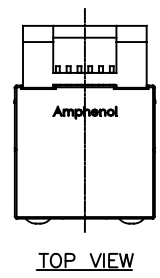

MATERIALS:
 PLASTIC HOUSING: ENGINEERING THERMOPLASTIC
 FLAMMABILITY RATING UL 94V-0

CONTACTS: PHOSPHOR BRONZE
 PLATING: 20 μ" [1.27 MICRONS]
 MIN. GOLD ON MATING SURFACES.
 50 μ" [1.27 MICRONS]
 MIN. NICKEL UNDERPLATE.
 100 μ" [2.54 MICRONS]
 MIN. MATTE TIN ON CONTACT

TAILS.

SHIELD: COPPER ALLOY
 PLATING: NICKEL

LIGHT PIPE: CLEAR POLYCARBONATE
 FLAMMABILITY RATING UL 94V-0

AMPHENOL PART NUMBER: RJJSE-5F81-01T

RECOMMENDED P.C.B. LAYOUT
(COMPONENT SIDE OF BOARD)

UNLESS SPECIFIED OTHERWISE	DRAWN RONNIE.C	FEB26/19	Amphenol Canada Corp. Commercial Products
PRIMARY UNITS INCHES	CHECKED L.CHAN	FEB26/19	
SECONDARY MILLIMETERS	M.E. APP'D		SINGLE PORT, SURFACE MOUNT RJ45, 8 POSITION, 8 CONTACTS, SHIELDED WITHOUT TABS, WITH LIGHT PIPE, T&R PACKAGING -RoHS COMPLIANT
REFERENCE IN PARENTHESES	Q.A. APP'D		
GENERAL TOLERANCES	DWG APP'D		DWG NO. P-RJSSSE-5F81-01T
1 DECIMAL PLACE	ENG. REL. NO.		
2 DECIMAL PLACES	REF. EAR# RJ19028		REV B
3 DECIMAL PLACES ±.015	THIRD ANGLE PROJECTION	DO NOT SCALE DRAWING	
ANGULAR DEGREES ±1.5°			CODE ID NO. 03554 DWG SIZE X SCALE N/A SHEET 1 OF 2

REVISIONS			
REV	DESCRIPTION, ECN, EAR NO.	DATE	APP'D
A	PROPOSAL PER EAR# RJ19028	FEB26/19	L.CHAN
B	FIX THE ERROR FOR VIEW	JUN30/20	L.CHAN

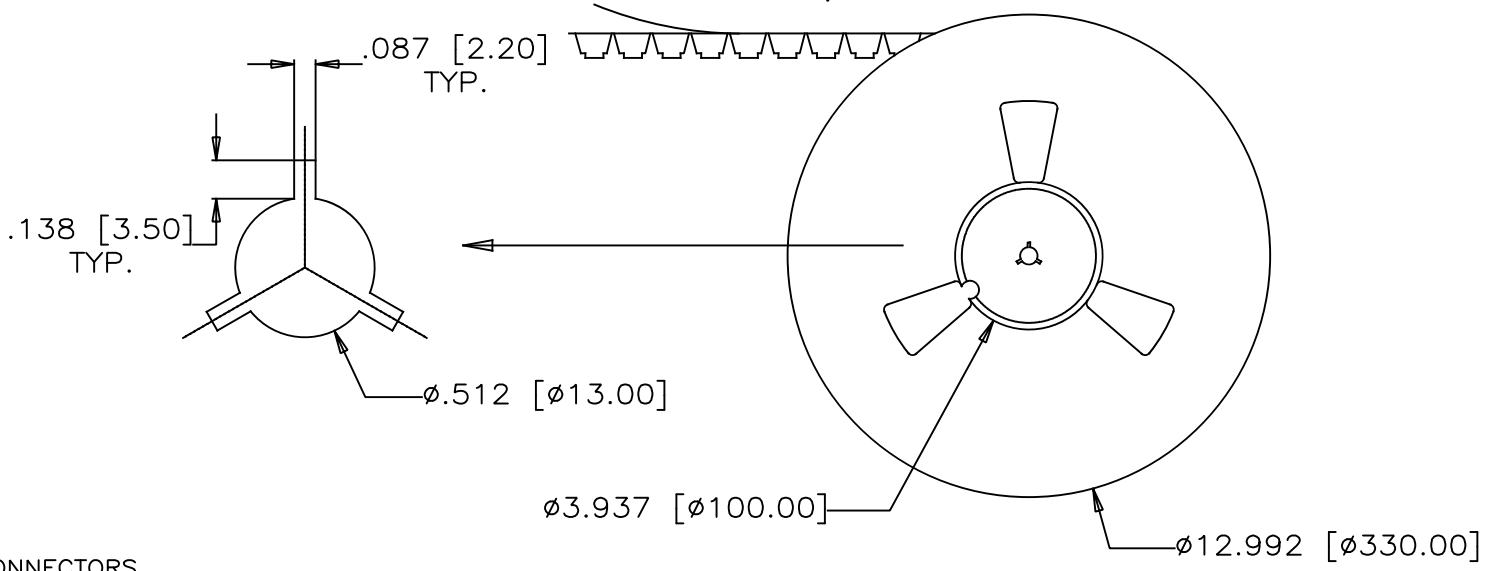
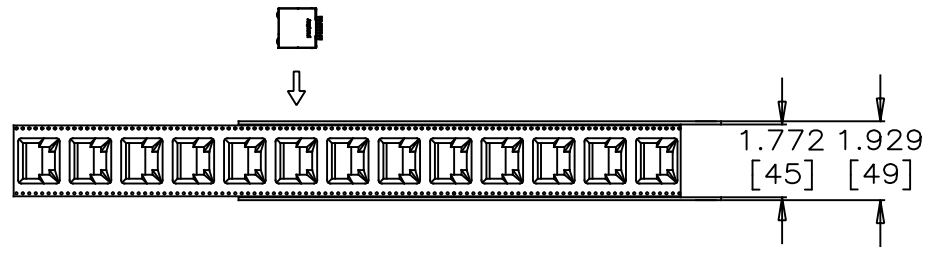
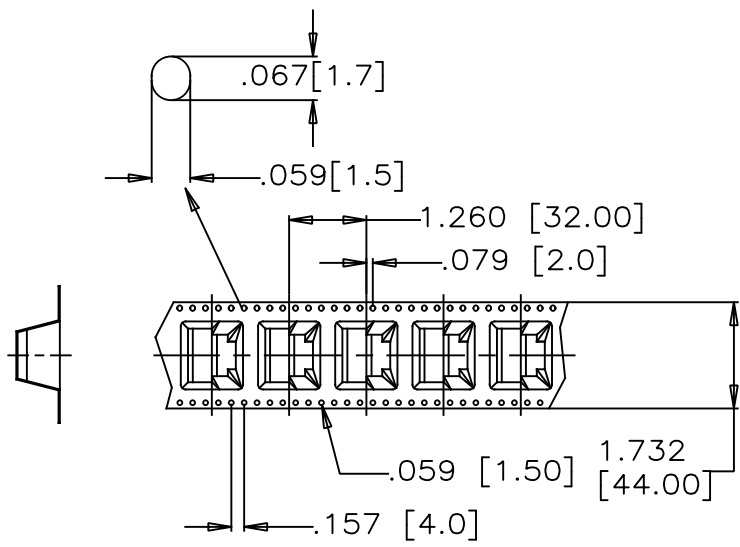

PACKAGING NOTES:

1. ONE REEL SHOULD HOLD 100 CONNECTORS.
2. 10 EMPTY CAVITIES FOR BOTH TOP AND BOTTOM OF THE CARRIER.
3. A FULLY LOADED CARTON SHOULD CONTAIN 5 REELS (500 PCS) OF CONNECTOR.

UNLESS SPECIFIED OTHERWISE		DRAWN RONNIE.C	FEB26/19	Amphenol Canada Corp.	
PRIMARY UNITS	INCHES	CHECKED L.CHAN	FEB26/19	Commercial Products	
SECONDARY	MILLIMETERS	M.E. APP'D		SINGLE PORT, SURFACE MOUNT RJ45,	
REFERENCE IN PARENTHESES		Q.A. APP'D		8 POSITION, 8 CONTACTS,	
GENERAL TOLERANCES		DWG APP'D		SHIELDED WITHOUT TABS, WITH LIGHT PIPE,	
1 DECIMAL PLACE		ENG. REL. NO.		T&R PACKAGING -RoHS COMPLIANT	
2 DECIMAL PLACES		REF. EAR# RJ19028		DWG NO.	P-RJSSE-5F81-01T
3 DECIMAL PLACES	±.015	THIRD ANGLE PROJECTION	DO NOT SCALE DRAWING	REV	B
ANGULAR DEGREES	±1.5°			CODE ID NO. 03554	DWG SIZE X SCALE N/A SHEET 2 OF 2