

ADM809-5L/ADM809-5S

FEATURES

Specified over temperature
Low power consumption: 17 μ A
Precision voltage monitor: 3 V, 5 V options
Reset assertion down to 1 V V_{CC}
30 ms minimum power-on reset
Logic low $\overline{\text{RESET}}$ output
Available in SOT-23 and SC70 packages

APPLICATIONS

Microprocessor systems
Computers
Controllers
Intelligent instruments
Automotive systems

GENERAL DESCRIPTION

The supervisory circuit of the ADM809-5L/ADM809-5S monitors the power supply voltage in microprocessor systems. It provides a reset output during power-up, power-down, and brownout conditions. On power-up, an internal timer holds reset asserted for 55 ms. This holds the microprocessor in a reset state until conditions have stabilized. The $\overline{\text{RESET}}$ output remains operational with V_{CC} as low as 1 V. The ADM809-5L/ADM809-5S provide an active low reset signal ($\overline{\text{RESET}}$).

The reset comparator features built-in glitch immunity, making it immune to fast transients on V_{CC} .

The ADM809-5L/ADM809-5S consume only 17 μ A, making them suitable for low power, portable equipment.

FUNCTIONAL BLOCK DIAGRAM

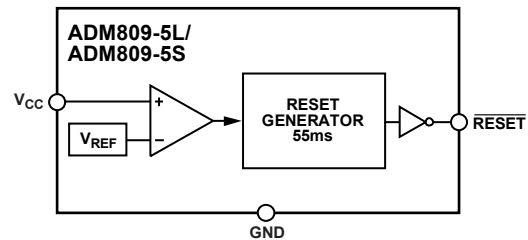

Figure 1.

100-06000

TYPICAL OPERATING CIRCUIT

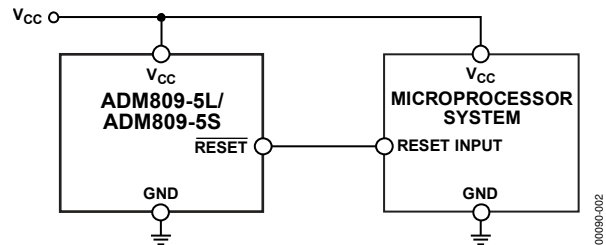

Figure 2.

2009-06000

Rev. B

Information furnished by Analog Devices is believed to be accurate and reliable. However, no responsibility is assumed by Analog Devices for its use, nor for any infringements of patents or other rights of third parties that may result from its use. Specifications subject to change without notice. No license is granted by implication or otherwise under any patent or patent rights of Analog Devices. Trademarks and registered trademarks are the property of their respective owners.

TABLE OF CONTENTS

Features	1	Pin Configuration and Function Descriptions.....	5
Applications.....	1	Typical Performance Characteristics	6
General Description	1	Theory of Operation	7
Functional Block Diagram	1	Interfacing to Output of Other Devices	7
Typical Operating Circuit.....	1	Ensuring a Valid Reset Output Down to $V_{CC} = 0\text{ V}$	7
Revision History	2	Benefits of a Very Accurate $\overline{\text{RESET}}$ Threshold	7
Specifications.....	3	Interfacing to Microprocessors with Multiple Interrupts.....	7
Absolute Maximum Ratings.....	4	Outline Dimensions	8
ESD Caution.....	4	Ordering Guide	8

REVISION HISTORY

10/08—Rev. A to Rev. B

Updated Format.....	Universal
Updated Outline Dimensions	8
Changes to Ordering Guide	8

3/03—Rev. 0 to Rev. A

Added SC70 Package.....	Universal
Changes to Features	1
Changes to Specifications	2
Changes to Absolute Maximum Ratings	2
Changes to Table I	3
Changes to Ordering Guide	3
Changes to TPC 2	4
Updated Outline Dimensions	6

SPECIFICATIONS

V_{CC} = full operating range, $T_A = T_{MIN}$ to T_{MAX} , V_{CC} typical = 5 V for L models and 3.3 V for S models, unless otherwise noted.

Table 1.

Parameter	Min	Typ	Max	Unit	Test Conditions/Comments
POWER SUPPLY					
V_{CC} Operating Voltage Range	1.0	3.3	5.5	V	$T_A = 0^\circ\text{C}$ to 150°C with 100 k Ω pull-down on output (Figure 10)
	1.2	3.3	5.5	V	$T_A = -40^\circ\text{C}$ to $+150^\circ\text{C}$ with 22 k Ω external pull-up on output (Figure 13)
Supply Current		24	60	μA	$V_{CC} < 5.5\text{ V}$, ADM809-5L, $T_A = -40^\circ\text{C}$ to $+150^\circ\text{C}$
		17	50	μA	$V_{CC} < 3.6\text{ V}$, ADM809-5S, $T_A = -40^\circ\text{C}$ to $+150^\circ\text{C}$
RESET VOLTAGE THRESHOLD					
ADM809-5L	4.5		4.75	V	$T_A = -40^\circ\text{C}$ to $+85^\circ\text{C}$
ADM809-5L	4.40		4.86	V	$T_A = 85^\circ\text{C}$ to 150°C
ADM809-5S	2.85		3.00	V	$T_A = -40^\circ\text{C}$ to $+85^\circ\text{C}$
ADM809-5S	2.78		3.08	V	$T_A = 85^\circ\text{C}$ to 150°C
RESET THRESHOLD TEMPERATURE COEFFICIENT		30		ppm/ $^\circ\text{C}$	
V_{CC} TO RESET DELAY		20		μs	$V_{CC} = V_{TH}$ to $(V_{TH} - 100\text{ mV})$
RESET ACTIVE TIMEOUT PERIOD	30	55	80	ms	$T_A = -40^\circ\text{C}$ to $+150^\circ\text{C}$
RESET OUTPUT VOLTAGE					
$\overline{\text{RESET}}$ Output Voltage Low			0.3	V	$V_{CC} = V_{TH}$ minimum, $I_{SINK} = 1.2\text{ mA}$, ADM809-5S
			0.4	V	$V_{CC} = V_{TH}$ minimum, $I_{SINK} = 3.2\text{ mA}$, ADM809-5L
			0.3	V	$V_{CC} > 1.0\text{ V}$, $I_{SINK} = 50\ \mu\text{A}$, $T_A = 0^\circ\text{C}$ to 150°C
$\overline{\text{RESET}}$ Output Voltage High	$0.8 V_{CC}$			V	$V_{CC} > 1.2\text{ V}$, $I_{SINK} = 50\ \mu\text{A}$, $T_A = -40^\circ\text{C}$ to $+150^\circ\text{C}$
	$V_{CC} - 1.5$			V	$V_{CC} > V_{TH}$ maximum, $I_{SOURCE} = 500\ \mu\text{A}$
				V	$V_{CC} > V_{TH}$ maximum, $I_{SOURCE} = 800\ \mu\text{A}$
JUNCTION TEMPERATURE	-40		+150	$^\circ\text{C}$	

ADM809-5L/ADM809-5S

ABSOLUTE MAXIMUM RATINGS

T_A = 25°C, unless otherwise noted.

Table 2.

Parameter	Rating
V _{CC}	-0.3 V to +6 V
$\overline{\text{RESET}}$	-0.3 V to V _{CC} + 0.5 V
Input Current	
V _{CC}	20 mA
Output Current	
$\overline{\text{RESET}}$	20 mA
Rate of Rise, V _{CC}	100 V/ μ s
θ_{JA} Thermal Impedance	
SOT-23	270°C/W
SC70	146°C/W
Lead Temperature (Soldering, 10 sec)	300°C
Vapor Phase (60 sec)	215°C
Infrared (15 sec)	220°C
Storage Temperature Range	-65°C to +150°C

Stresses above those listed under Absolute Maximum Ratings may cause permanent damage to the device. This is a stress rating only; functional operation of the device at these or any other conditions above those indicated in the operational section of this specification is not implied. Exposure to absolute maximum rating conditions for extended periods may affect device reliability.

ESD CAUTION



ESD (electrostatic discharge) sensitive device. Charged devices and circuit boards can discharge without detection. Although this product features patented or proprietary protection circuitry, damage may occur on devices subjected to high energy ESD. Therefore, proper ESD precautions should be taken to avoid performance degradation or loss of functionality.

PIN CONFIGURATION AND FUNCTION DESCRIPTIONS

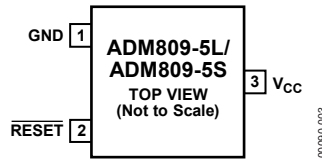
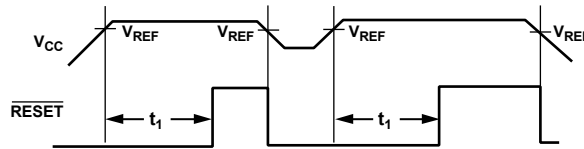

Figure 3. Pin Configuration

Table 3. Pin Function Descriptions

Pin No.	Mnemonic	Function
1	GND	Ground Reference for All Signals (0V).
2	RESET	Active Low Logic Output. $\overline{\text{RESET}}$ remains low while V_{CC} is below the reset threshold, and remains low for 55 ms (typical) after V_{CC} rises above the reset threshold.
3	V_{CC}	Supply Voltage Being Monitored.



NOTES

- $t_1 = \overline{\text{RESET}} \text{ TIME} = 55\text{ms TYPICAL.}$
- $V_{REF} = \overline{\text{RESET}} \text{ VOLTAGE THRESHOLD.}$

Figure 4. Power Fail $\overline{\text{RESET}}$ Timing

Table 4. $\overline{\text{RESET}}$ Threshold Options

Model	$\overline{\text{RESET}}$ Threshold (V)
ADM809-5L	4.63
ADM809-5S	2.93

ADM809-5L/ADM809-5S

TYPICAL PERFORMANCE CHARACTERISTICS

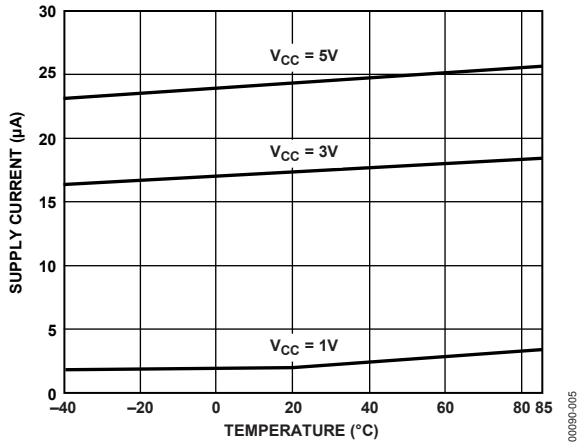

Figure 5. Supply Current vs. Temperature (No Load)

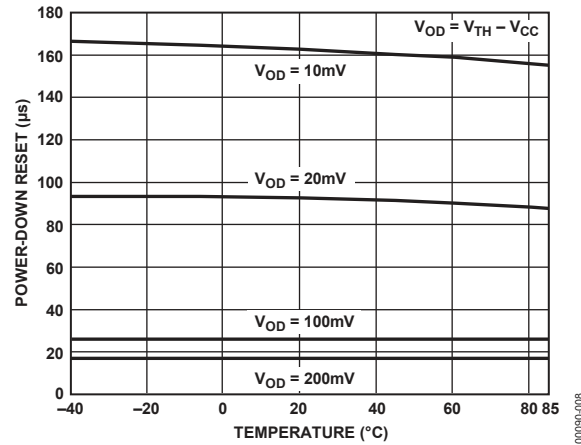

Figure 8. ADM809-5S Power-Down Reset Delay vs. Temperature

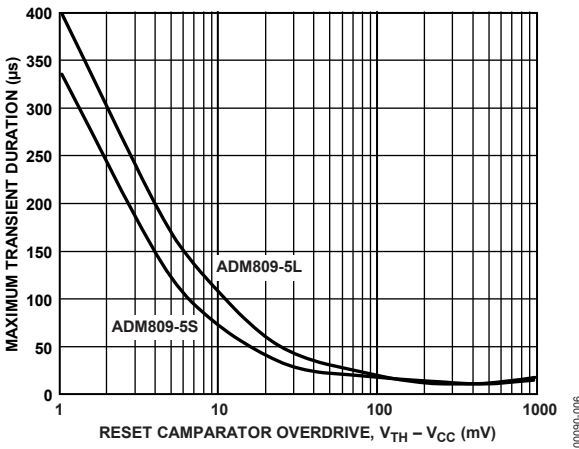

Figure 6. Maximum Transient Duration Without Causing a Reset Pulse vs. Reset Comparator Overdrive

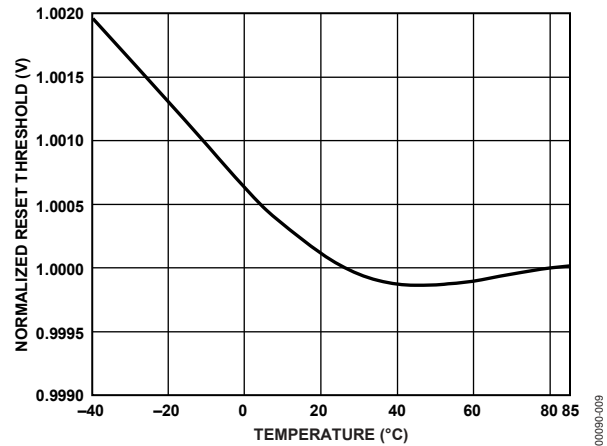

Figure 9. Normalized Reset Voltage Threshold vs. Temperature

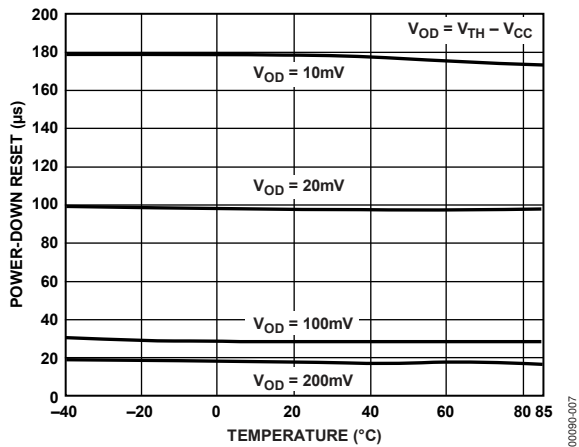

Figure 7. ADM809-5L Power-Down Reset Delay vs. Temperature

THEORY OF OPERATION

INTERFACING TO OUTPUT OF OTHER DEVICES

The ADM809-5L/ADM809-5S are designed to integrate with as many devices as possible and, therefore, have an output dependent on V_{CC} . Because of this design approach, interfacing these devices to other devices is simplified.

ENSURING A VALID RESET OUTPUT DOWN TO $V_{CC} = 0V$

When V_{CC} falls below 0.8 V, the ADM809-5L/ADM809-5S \overline{RESET} no longer sinks current. A high impedance CMOS logic input connected to \overline{RESET} may, therefore, drift to undetermined logic levels. To eliminate this problem, a 100 k Ω resistor should be connected from \overline{RESET} to ground.

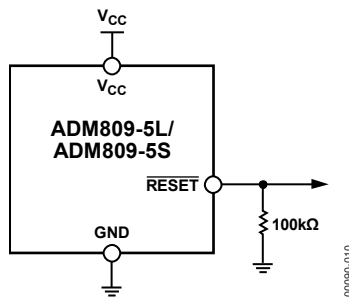

Figure 10. Ensuring a Valid \overline{RESET} Output Down to $V_{CC} = 0V$

BENEFITS OF A VERY ACCURATE \overline{RESET} THRESHOLD

In other microprocessor supervisory circuits, tolerances in supply voltages lead to an overall increase in \overline{RESET} tolerance levels due to the deterioration of the \overline{RESET} circuit power supply of the microprocessor. The possibility of a malfunction during a power failure is greatly reduced because the ADM809-5L/ADM809-5S can operate effectively even when there are large degradations of the supply voltages. Another advantage of the ADM809-5L/ADM809-5S series is its very accurate internal voltage reference circuit. These benefits combine to produce an exceptionally reliable voltage monitor circuit.

INTERFACING TO MICROPROCESSORS WITH MULTIPLE INTERRUPTS

In a number of cases, it is necessary to interface to many interrupts from different devices (for example, from thermal, attitude, and velocity sensors). The ADM809-5L/ADM809-5S can be easily integrated into existing interrupt-handling circuits (see Figure 13) or used as standalone devices.

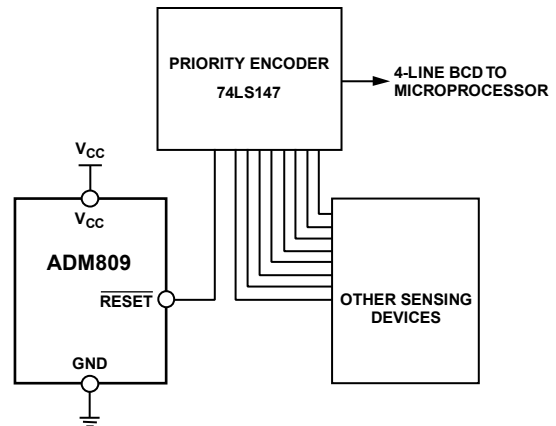

Figure 11. Interfacing to Microprocessors with Multiple Interrupts

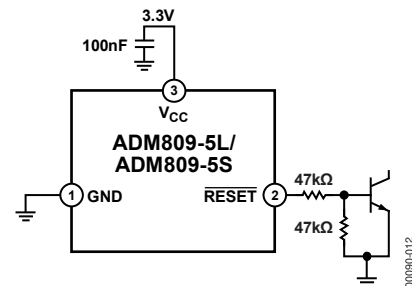

Figure 12. Alternative Application Circuit with Extra Decoupling

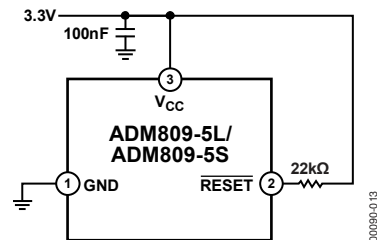
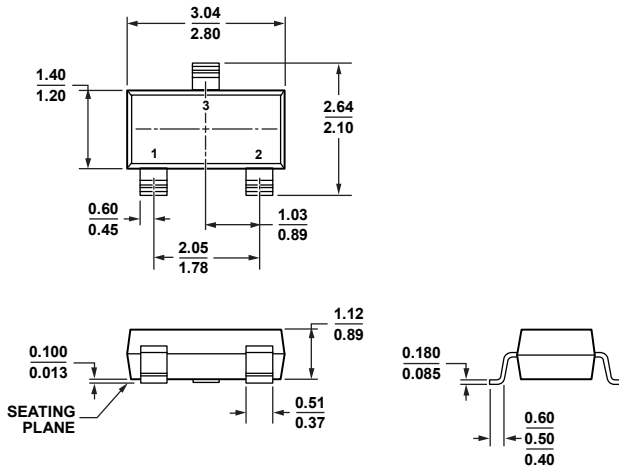

Figure 13. Additional Decoupling Can Be Achieved Using a 100 nF Capacitor Between V_{CC} and Ground

OUTLINE DIMENSIONS



COMPLIANT TO JEDEC STANDARDS TO-236-AB

Figure 14. 3-Lead Small Outline Transistor Package [SOT-23] (RT-3)

Dimensions shown in millimeters

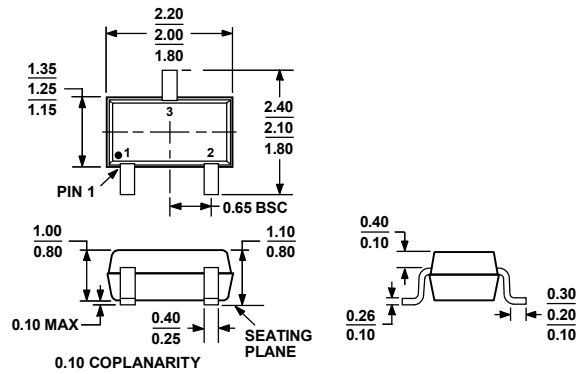

ALL DIMENSIONS COMPLIANT WITH EIAJ SC70

Figure 15. 3-Lead Thin Shrink Small Outline Transistor Package [SC70] (KS-3)

Dimensions shown in millimeters

ORDERING GUIDE

Model	Reset Threshold (V)	Temperature Range	Branding Information	Quantity (K)	Package Description	Package Option
ADM809-5LART-REEL	4.63	-40°C to +150°C	M9L	10	3-Lead SOT-23	RT-3
ADM809-5LART-REEL7	4.63	-40°C to +150°C	M9L	3	3-Lead SOT-23	RT-3
ADM809-5LARTZ-REEL ¹	4.63	-40°C to +150°C	M6Q	10	3-Lead SOT-23	RT-3
ADM809-5LARTZ-RL7 ¹	4.63	-40°C to +150°C	M6Q	3	3-Lead SOT-23	RT-3
ADM809-5LAKS-REEL	4.63	-40°C to +150°C	M9L	10	3-Lead SC70	KS-3
ADM809-5LAKS-REEL7	4.63	-40°C to +150°C	M9L	3	3-Lead SC70	KS-3
ADM809-5LAKSZ-REEL ¹	4.63	-40°C to +150°C	M6Q	10	3-Lead SC70	KS-3
ADM809-5LAKSZ-RL7 ¹	4.63	-40°C to +150°C	M6Q	3	3-Lead SC70	KS-3
ADM809-5SART-REEL	2.93	-40°C to +150°C	M9S	10	3-Lead SOT-23	RT-3
ADM809-5SART-REEL7	2.93	-40°C to +150°C	M9S	3	3-Lead SOT-23	RT-3
ADM809-5SARTZ-REEL ¹	2.93	-40°C to +150°C	M4C	10	3-Lead SOT-23	RT-3
ADM809-5SARTZ-RL7 ¹	2.93	-40°C to +150°C	M4C	3	3-Lead SOT-23	RT-3
ADM809-5SAKS-REEL	2.93	-40°C to +150°C	M9S	10	3-Lead SC70	KS-3
ADM809-5SAKS-REEL7	2.93	-40°C to +150°C	M9S	3	3-Lead SC70	KS-3
ADM809-5SAKSZ-RL ¹	2.93	-40°C to +150°C	M4C	10	3-Lead SC70	KS-3
ADM809-5SAKSZ-RL7 ¹	2.93	-40°C to +150°C	M4C	3	3-Lead SC70	KS-3

¹ Z = RoHS Compliant Part.