

THIS DRAWING IS UNPUBLISHED. RELEASED FOR PUBLICATION
 © COPYRIGHT 20- BY TYCO ELECTRONICS CORPORATION. ALL RIGHTS RESERVED.

LOC	DIST	REVISIONS			
P	LTR	DESCRIPTION	DATE	DWN	APVD
GP	00	C1	REVISED PER ECO-06-012000	24AUG06	JRP SS

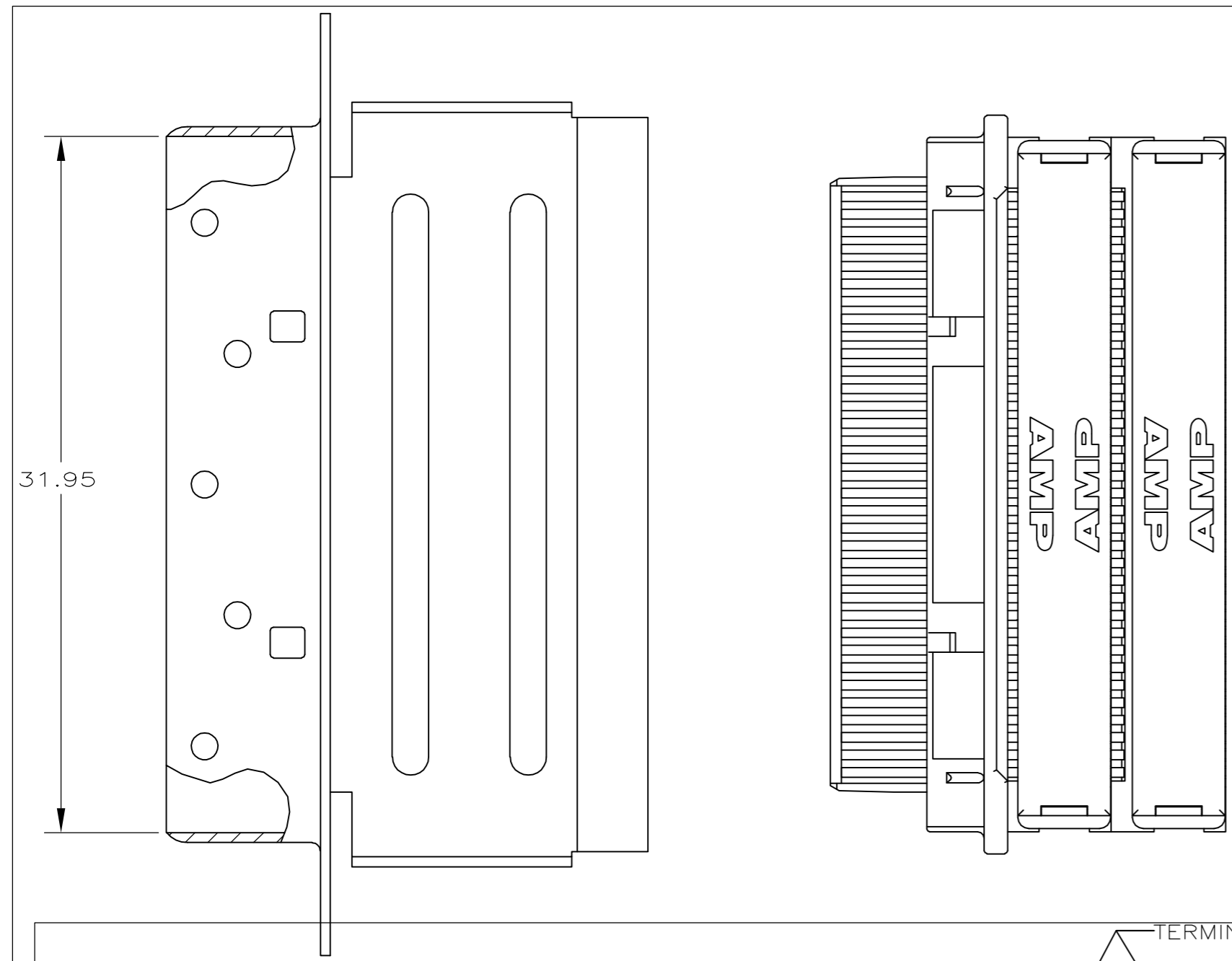

- 1 MATERIAL:
 PLUG CONTACTS - PHOSPHOR BRONZE.
 PLUG SHELL - CARBON STEEL.
 PLUG HOUSING - LCP, NATURAL, RATED UL 94V-0.
 TERMINATION COVERS - LCP, BLACK, RATED UL 94V-0.
- 2 PLATING:
 PLUG CONTACTS - 0.76µm MINIMUM GOLD PLATE IN LOCALIZED GOLD PLATE AREA, 1.27µm MINIMUM TIN-LEAD PLATE IN TERMINATION AREA, ALL OVER 1.27µm MINIMUM NICKEL.
 PLUG SHELL - 5.08µm MINIMUM NICKEL OVER 1.27µm MINIMUM COPPER.
- 3 TERMINATION COVERS AND PLUG SHELL ARE PACKAGED UNASSEMBLED.
- 4. RECOMMENDED WIRE: 30 AWG WITH A 0.56-0.64 INSULATION DIAMETER, WIRE MUST BE APPROVED BY AMP ENGINEERING.

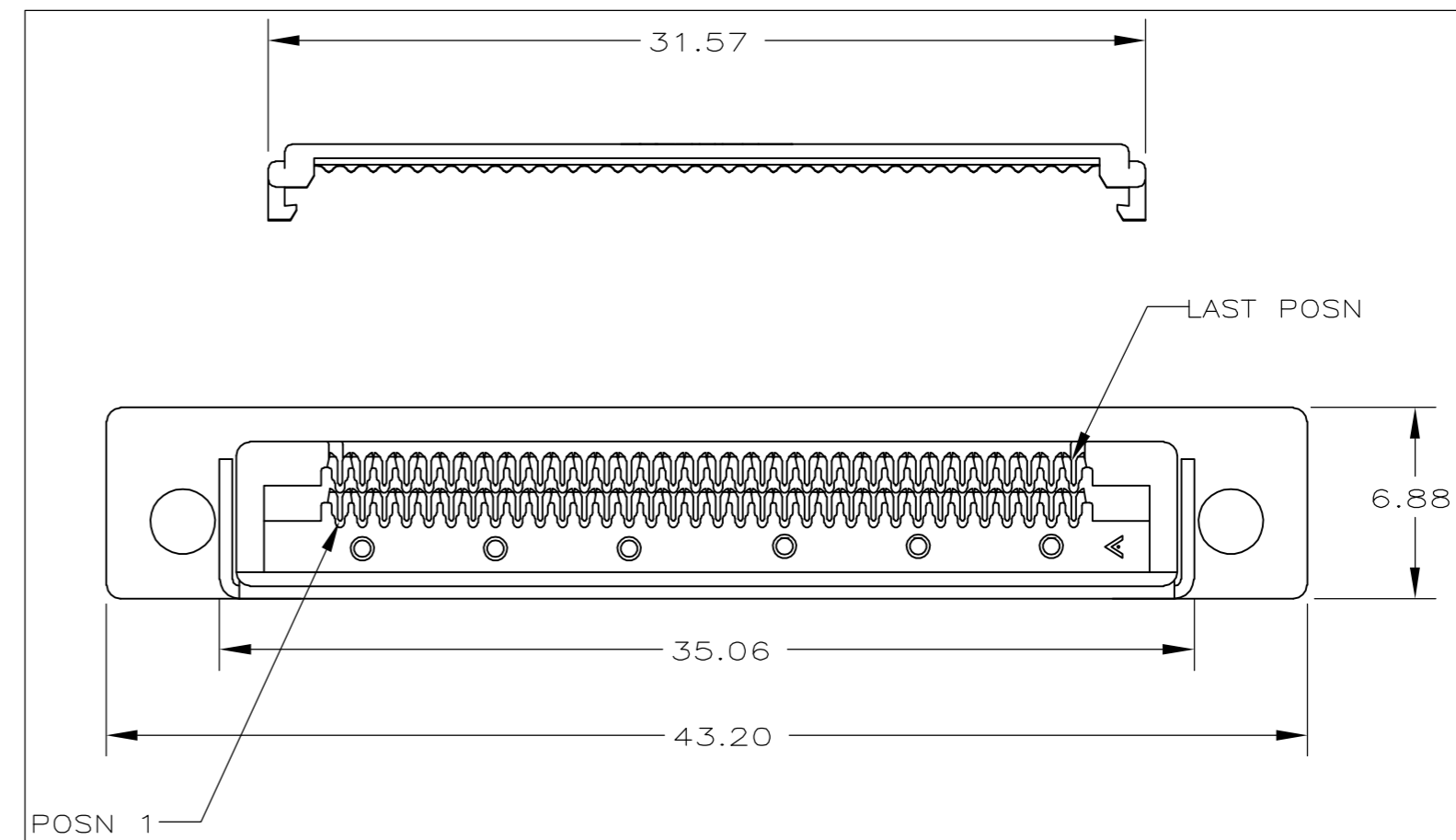
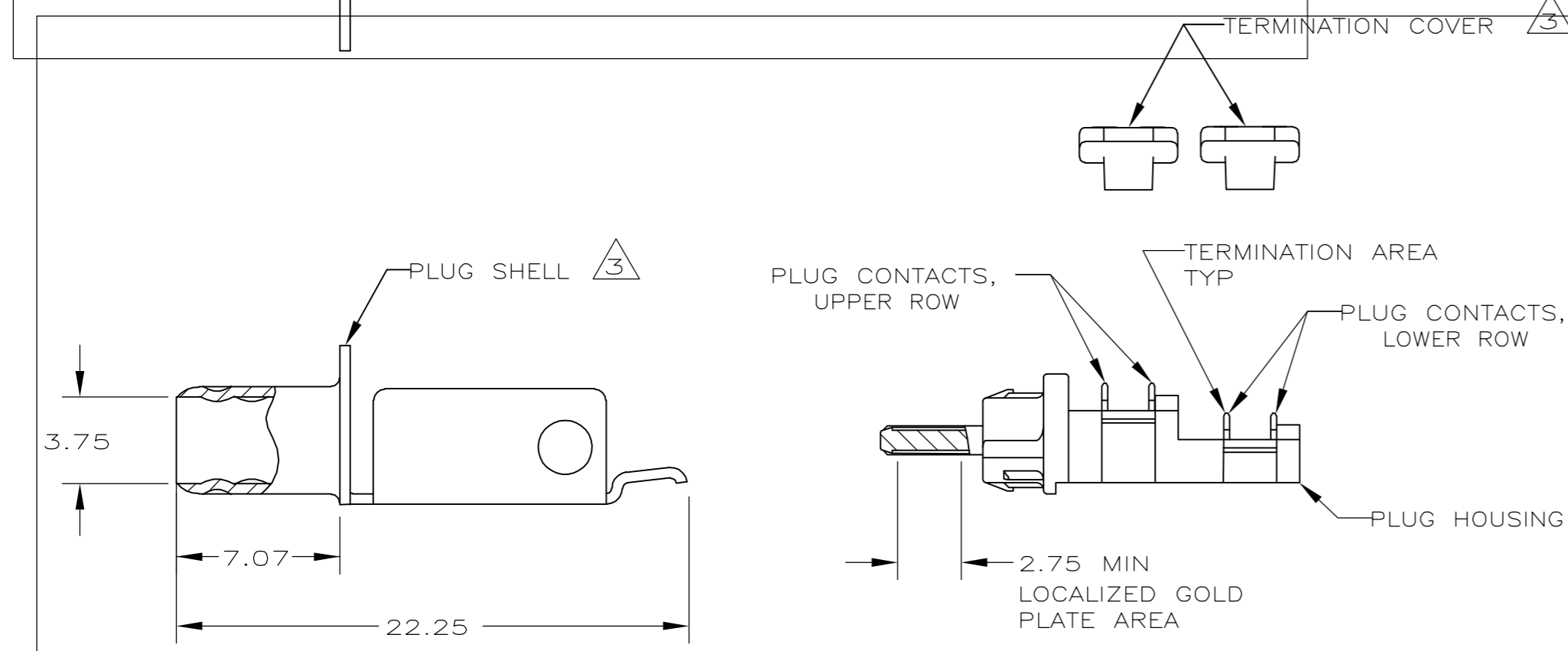

787775-1
 PART NUMBER

THIS DRAWING IS A CONTROLLED DOCUMENT.		DWN T.SHUEY 08MAR05	Tyco Electronics Corporation Harrisburg, Pa 17105-3608	
DIMENSIONS: mm		CHK J.GERACE 08MAR05		
TOLERANCES UNLESS OTHERWISE SPECIFIED:		APVD M.WALMSLEY 08MAR05	NAME PLUG KIT, UNASSEMBLED, 68 POSN, CHAMP 0.8MM OFFSET CABLE CONNECTOR	
0 PLC ± - 1 PLC ± - 2 PLC ± 0.13 3 PLC ± - 4 PLC ± - ANGLES ± - FINISH		PRODUCT SPEC 108-1471	SIZE A2	CAGE CODE 00779
MATERIAL		WEIGHT -	DRAWING NO C=787775	RESTRICTED TO -
1		CUSTOMER DRAWING		SCALE 4:1
2		SHEET 1 OF 1		REV C1