

MAX9867 Evaluation Kit

Evaluates: MAX9867

General Description

The MAX9867 evaluation kit (EV kit) consists of a MAX9867 evaluation board and software. The EV kit is a fully assembled and tested circuit board that evaluates the MAX9867 low-power, stereo audio codec. The EV kit is designed to send and receive digital audio data in the Sony/Philips digital interface (S/PDIF) format and can be optionally configured to communicate using generic digital audio or I²S-compatible signals.

The EV kit provides two RCA jacks for analog audio input signals and two 3.5mm headphone jacks for analog audio output signals. The EV kit also provides fiber optic receiving and transmitting modules for digital audio input and output.

The EV kit includes Windows® 2000-, Windows XP®, and Windows Vista®-compatible software that provides a graphical user interface (GUI) for exercising the features of the MAX9867. The EV kit is connected to a PC through a USB A-to-mini-B cable.

Features

- ◆ **USB-PC Connection (Cable Included)**
- ◆ **USB Powered (External Power Supply Not Required)**
- ◆ **On-Board 12.288MHz and 13MHz Clock Oscillators**
- ◆ **On-Board Digital Audio Interface Transceiver**
- ◆ **On-Board Fiber Optic Transmitter and Receiver Modules**
- ◆ **Isolation Header for Direct Communication with the MAX9867 I²C and Digital Audio Interfaces**
- ◆ **Proven PCB Layout**
- ◆ **Windows 2000-, Windows XP-, and Windows Vista (32-Bit)-Compatible Software**

Ordering Information

PART	TYPE
MAX9867EVKIT+	EV Kit

+Denotes lead(Pb)-free and RoHS compliant.

System Diagram

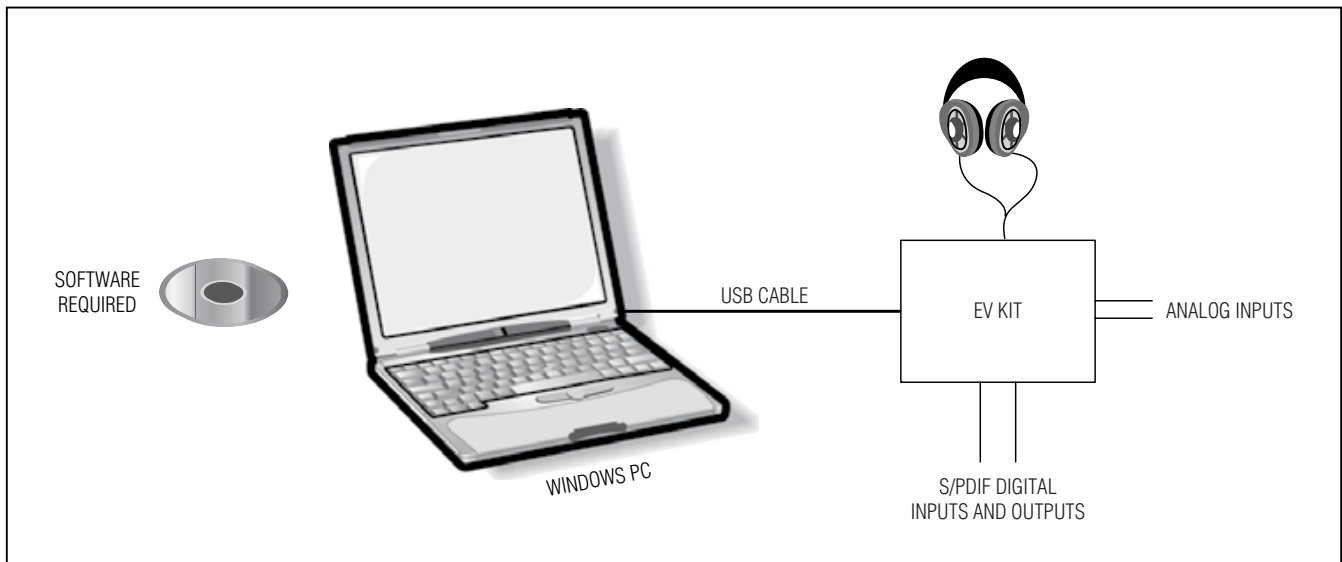

Windows, Windows XP, and Windows Vista are registered trademarks of Microsoft Corp.

For pricing, delivery, and ordering information, please contact Maxim Direct at 1-888-629-4642, or visit Maxim's website at www.maximintegrated.com.

MAX9867 Evaluation Kit

Evaluates: MAX9867

Component List

DESIGNATION	QTY	DESCRIPTION
REQUIRED COMPONENTS		
C1–C8, C10, C12, C13, C16, C17	13	1.0 μ F \pm 10%, 6.3V X5R ceramic capacitors (0402) Murata GRM155R60J105K
C9	1	2.2 μ F \pm 20%, 6.3V X5R ceramic capacitor (0402) Murata GRM155R60J225M
SUPPORT COMPONENTS		
C11, C18	2	220 μ F \pm 20%, 4V tantalum capacitors (1206) Nichicon F950G227MSAAQ2
C14, C15	2	1.0 μ F \pm 10%, 6.3V X5R ceramic capacitors (0402) Murata GRM155R60J105K
C19, C20, C31–C34, C37, C38	8	0.01 μ F \pm 10%, 16V X7R ceramic capacitors (0603) Murata GRM188R71C103K
C21, C22, C27, C29, C35, C40, C42, C44–C47, C51	12	0.1 μ F \pm 10%, 16V X5R ceramic capacitors (0603) Murata GRM188R61C104K
C23–C26, C43, C50, C53, C54	8	1 μ F \pm 10%, 10V X5R ceramic capacitors (0603) Murata GRM188R61A105K
C28	1	0.047 μ F \pm 10%, 16V X7R ceramic capacitor (0603) Murata GRM188R71C473K
C30	1	0.47 μ F \pm 10%, 16V X7R ceramic capacitor (0603) Murata GRM188R71C474K
C36, C41	2	10pF \pm 5%, 50V C0G ceramic capacitors (0603) Murata GRM1885C1H100J
C39	1	0.033 μ F \pm 10%, 16V X7R ceramic capacitor (0603) Murata GRM188R71C333K
C48, C49	2	22pF \pm 5%, 50V C0G ceramic capacitors (0603) Murata GRM1885C1H220J
C52	1	10 μ F \pm 10%, 6.3V X5R ceramic capacitor (0805) Murata GRM219R60J106K

DESIGNATION	QTY	DESCRIPTION
C55, C56	2	0.1 μ F \pm 10%, 10V X5R ceramic capacitors (0402) Murata GRM155R61A104K
C57–C61	0	Not installed, ceramic capacitors (0402)
D1	1	Surface-mount yellow LED (0603)
D2	1	Surface-mount red LED (0603)
FB1, FB2	2	0.1 Ω DCR, 60 Ω at 100MHz ferrite beads Murata BLM18PG600SN1
J1	1	White phono jack (side entry, PCB mount)
J2	1	Red phono jack (side entry, PCB mount)
J3, J4	2	Surface-mount 3.5mm stereo headphone jacks
J5	1	Digital audio fiber optic transmitter module Toshiba TOTX147L(F,T)
J6	1	Digital audio fiber optic receiver module Toshiba TORX147L(F,T)
J7	1	Mini-B USB jack
JU1–JU11, JU14–JU18	16	2-pin headers
JU12	1	3-pin header
JU13	1	21-pin header (3 x 7)
L1	1	47 μ H \pm 5%, 200mA inductor (1812) Coilcraft 1812LS-473XJLB
R1–R4	4	2.2k Ω \pm 5% resistors (0402)
R5, R6, R8	3	10k Ω \pm 5% resistors (0402)
R7, R11, R15, R16, R29	0	Not installed, resistors (0402)
R9, R10, R12, R13, R14	5	75 Ω \pm 5% resistors (0402)
R17	1	402 Ω \pm 5% resistor (0603)
R18	1	47k Ω \pm 5% resistor (0603)
R19, R20	2	220 Ω \pm 5% resistors (0603)
R21, R22, R23	3	1.5k Ω \pm 5% resistors (0603)
R24, R25	2	27 Ω \pm 5% resistors (0603)

MAX9867 Evaluation Kit

Evaluates: MAX9867

Component List (continued)

DESIGNATION	QTY	DESCRIPTION
R26	1	470Ω ±5% resistor (0603)
R27	1	2.2kΩ ±5% resistor (0603)
R28	1	10kΩ ±5% resistor (0603)
R30	1	0Ω ±5% resistor (0402)
U1	1	Stereo audio codec (30 WLP) Maxim MAX9867EWW+
U2, U3	2	Low-noise linear regulators (5 SC70) Maxim MAX8510EXK18+
U4	1	Digital audio transceiver (28 SO) Cirrus Logic CS8427-CSZ
U5, U6	2	2:1 high-speed muxes (6 SC70)
U7	1	USB-to-UART converter (32 TQFP)
U8	1	Microcontroller (56 TQFN-EP*) Maxim MAXQ2000-RBX+
U9	1	Low-noise linear regulator (5 SC70) Maxim MAX8511EXK33+

DESIGNATION	QTY	DESCRIPTION
U10	1	93C46 type 3-wire EEPROM (8 SO)
U11	1	Low-noise linear regulator (5 SC70) Maxim MAX8511EXK25+
U12, U13	2	Digital microphones (6 LGA) Akustika AKU2002C
Y1	1	12.288MHz clock oscillator
Y2	1	13MHz clock oscillator Hong Kong X'tals C4M13000NSMI02601-0
Y3	1	16MHz surface-mount crystal oscillator
Y5	1	6MHz surface-mount crystal oscillator
—	1	USB high-speed A-to-mini-B cable, 6ft
—	24	Shunts
—	1	PCB: MAX9867 EVALUATION KIT+

*EP = Exposed pad.

Component Suppliers

SUPPLIER	PHONE	WEBSITE
Coilcraft, Inc.	847-639-6400	www.coilcraft.com
Hong Kong X'tals Ltd.	852-35112388	www.hongkongcrystal.com
Murata Electronics North America, Inc.	770-436-1300	www.murata-northamerica.com
Toshiba America Electronic Components, Inc.	949-623-2900	www.toshiba.com/taec

Note: Indicate that you are using the MAX9867 when contacting these component suppliers.

MAX9867 EV Kit Files

FILE	DESCRIPTION
INSTALL.EXE	Installs the EV kit files on your computer
MAX9867.EXE	Application program
FTDIBUS.INF	USB device driver file
UNINST.EXE	Uninstalls the EV kit software
USB_Driver_Help.PDF	USB driver installation help file

MAX9867 Evaluation Kit

Evaluates: MAX9867

Quick Start

Recommended Equipment

- MAX9867 EV kit (USB A-to-mini-B cable included)
- User-supplied Windows 7 or Windows 8 PC with a spare USB port
- Pair of headphones (16Ω or greater)
- Two single-ended analog audio sources
- Digital audio equipment with two TOSLINK optical cables

Refer to the MAX9867 IC data sheet while using this EV kit for detailed descriptions of the codec's features.

Note: In the following sections, software-related items are identified by bolding. Text in **bold** refers to items directly from the EV kit software. Text in **bold and underlined** refers to items from the Windows operating system.

Procedure

The MAX9867 EV kit is fully assembled and tested. Follow the steps below to verify board operation before exercising the full features of the MAX9867:

- 1) Verify that all the jumpers are set in their default positions, as shown in Table 1.
- 2) Connect one TOSLINK optical cable between the digital audio equipment input and the J5 module on the EV kit board.
- 3) Connect the other TOSLINK optical cable between the digital audio equipment output and the J6 module on the EV kit board.
- 4) Connect one analog audio source to the MICLP and MICLN pads on the EV kit board. Connect the MICLN pad to GND for single-ended microphone input.
- 5) Connect the other analog audio source to the MICRP and MICRN pads on the EV kit board. Connect the MICRN to GND for single-ended microphone input.
- 6) Connect one analog audio source to the J1 RCA jack on the EV kit board.
- 7) Connect the other analog audio source to the J2 RCA jack on the EV kit board.
- 8) Connect the headphone to the J4 headphone jack on the EV kit board.
- 9) Set the digital audio equipment audio output and input sampling frequency to 48kHz.
- 10) Enable the digital audio equipment input and output.
- 11) Enable the analog audio sources.
- 12) Visit www.maximintegrated.com/evkitsoftware to download the latest version of the EV kit software, MAX9867EVSwSetupVx.x.ZIP.
- 13) Install the MAX9867 evaluation software on your computer by running the MAX9867EVSwSetupVx.x.exe program. The program files are copied and icons are created in the Windows **Start** menu.
- 14) Connect the USB cable from the PC to the EV kit board. A **New Hardware Found** window pops up when installing the USB driver for the first time. If a window is not seen that is similar to the one described above after 30s, remove the USB cable from the board and reconnect it. Administrator privileges are required to install the USB device driver on Windows.
- 15) Follow the directions of the **Found New Hardware** window to install the USB device driver. Manually specify the location of the device driver to be **C:\Program Files\Maxim Integrated\MAX9867** (default installation directory) using the **Browse** button. During device driver installation, Windows may show a warning message indicating that the device driver Maxim uses does not contain a digital signature. This is not an error condition and it is safe to proceed with installation. Refer to the USB_Driver_Help.PDF document included with the software for additional information.
- 16) Start the MAX9867 EV kit software by opening its icon in the **Start | Programs | Maxim Integrated | MAX9867** menu.
- 17) The EV kit software main window appears, as shown in Figure 1. Verify that the message **MAX9867: Connected** is displayed on the status bar at the bottom of the software's main window.
- 18) In the **Clock Configuration** group box, press the **Configure** button.
- 19) In the **MCLK Sources** group box, click on the **Recovered Master Clock** radio button.
- 20) Click on the **DAC and Headphone Outputs** tab. In the **Headphone Output Mode** drop-down list, select **Stereo OCL**.
- 21) Click on the **Mic and Line Inputs** tab. In the **Line Inputs** group box, check the **Enable Left Line In**, **Enable Right Line In**, **Mute Left Line In**, and **Mute Right Line In** checkboxes. Muting the input does not prevent the input from routing to the ADCs.
- 22) Click on the **Filters** tab. In the **Codec Filtering Mode** drop-down list, select **Audio (FIR)**.

MAX9867 Evaluation Kit

Evaluates: MAX9867

- 23) On the top-right corner of the software's main window, select **Enabled** from the drop-down list.
- 24) Verify that audio from the digital audio equipment is output at the headphone and the analog audio sources are output to the digital audio equipment.

Detailed Description of Software

Software Main Window

On the top of the main window, press the **Read All** button to read all the MAX9867 register values and update the GUI. Press **Reset** to reset the EV kit hardware. Press **Connected** to set up the connection between the EV kit

and the software application. The drop-down list allows a user to enable or disable the MAX9867.

The **Device Status** group box reports the status of various device functions. Check/uncheck the checkboxes to enable/disable the hardware interrupts for each status flag.

The lower side of the main window includes eight tabs. On each tab sheet, the user can exercise a group of related configurations and check the register values. Each control on the GUI generates the expected read and/or write operations on the internal registers of the MAX9867 and the CS8427 digital audio transceiver.

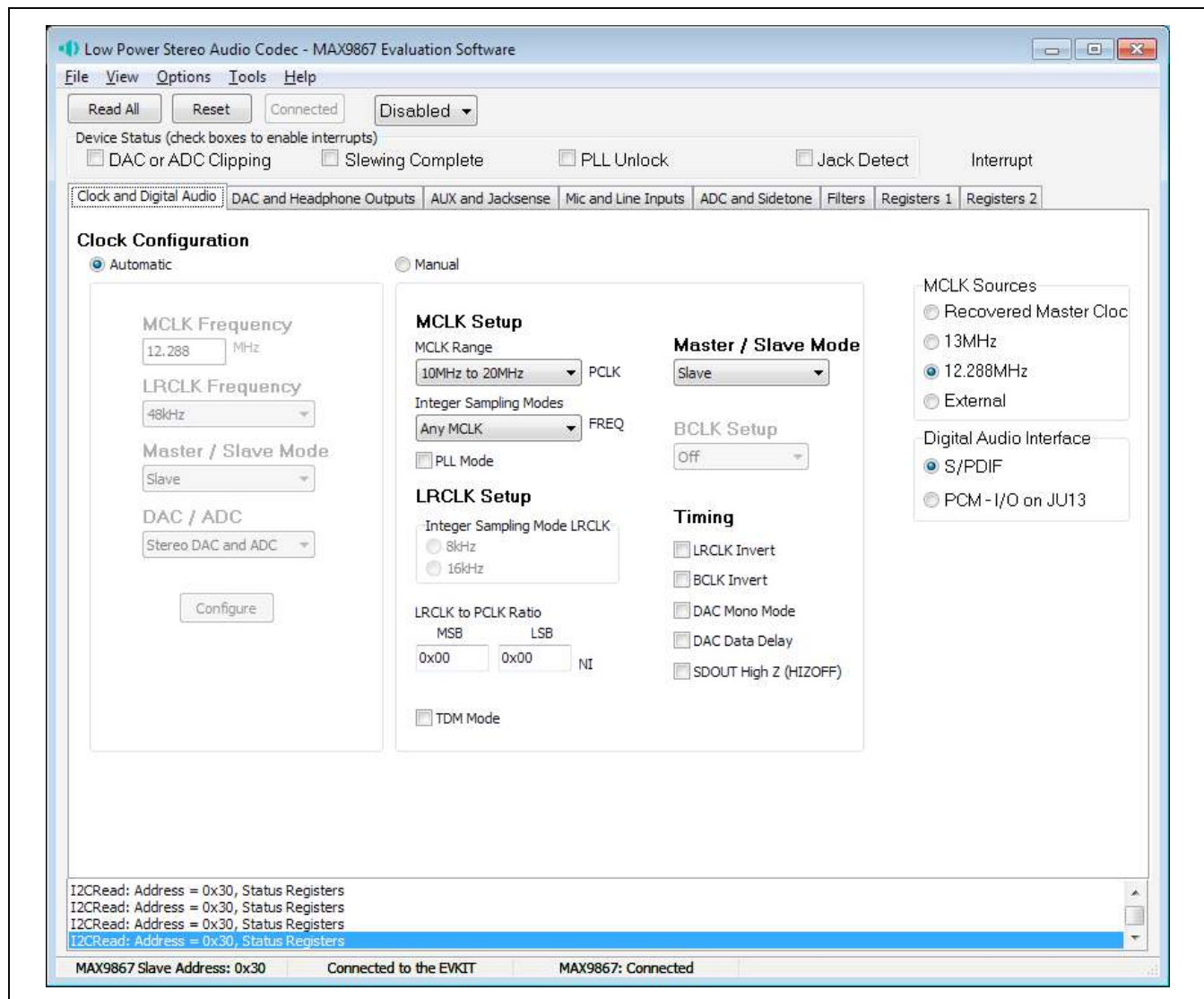

Figure 1. MAX9867 Evaluation Software (Main Window)

MAX9867 Evaluation Kit

Evaluates: MAX9867

File Menu

Select the **Save Configuration** menu item to save the current EV kit configuration to a text file that can be loaded at a later time. Select **Load Configuration** to reload settings from a saved file.

Select **Exit** to exit the application.

View Menu

Select the **Show Test Mode Registers** menu item to display or hide the MAX9867 trim registers and test registers tab sheets.

Select **Show CS8427 Registers** to display or hide the **CS8427** tab to change the digital audio transceiver registers.

Options Menu

Select the **Power On Reset** menu item to reset the MAX9867 to its power-on state. Select **Read Status** to read the MAX9867 status registers. Select **Auto Read Status** to enable the automatic read of the MAX9867 status registers. Select **Auto Connect** to automatically set up the connection between the EV kit and the software application in case the connection is lost.

Tools Menu

Select the **Reconnect to EVKIT** menu item to set up the connection between the EV kit and the software application.

Select **Debug Mode** to bring up the **Advanced User Interface** window. The interface allows I²C operations, such as read byte and write byte, to be executed. The I²C dialog boxes accept numeric data in binary, decimal, or hexadecimal. Hexadecimal numbers should be prefixed by \$ or 0x. Binary numbers must be exactly eight digits. See Figure 2 for an example of this control method.

Help Menu

Select the **Help** menu item for information about the software.

Clock and Digital Audio Tab

The **Clock and Digital Audio** tab sheet (Figure 1) contains the master clock (MCLK) and digital audio interface selections for the MAX9867. A user can select an automatic typical interface configuration or manually configure the device according to specific requirements.

DAC and Headphone Outputs Tab

The **DAC and Headphone Outputs** tab sheet (Figure 3) includes the DAC enable and gain controls. It also includes the headphone output mute, level, and mode controls.

AUX and Jacksense Tab

The **AUX and Jacksense** tab sheet (Figure 4) includes the measurement control of an AUX input. It also includes the jack detection controls. Do not use the DC-voltage measurement and jack detection at the same time.

Mic and Line Inputs Tab

The **Mic and Line Inputs** tab sheet (Figure 5) includes the microphone and the line input controls.

ADC and Sidetone Tab

The **ADC and Sidetone** tab sheet (Figure 6) includes the controls for the ADC and the sidetone circuitry on the MAX9867.

Filters Tab

The **Filters** tab sheet (Figure 7) controls the functionality of the DAC and ADC filters on the MAX9867.

Registers 1 and Registers 2 Tabs

The **Registers 1** tab sheet (Figure 8) and the **Registers 2** tab sheet (Figure 9) list all of the MAX9867 **registers**. To change a register value, type in the new value in the appropriate edit box and press the Enter key on the keyboard, or click the bit names on the GUI.

CS8427 Tab

The **CS8427** tab sheet (Figure 10) displays the EV kit-related CS8427 register values on one page. To change a register value, type in the new value in the appropriate edit box and press the Enter key on the keyboard, or click the bit names on the GUI.

MAX9867 Evaluation Kit

Evaluates: MAX9867

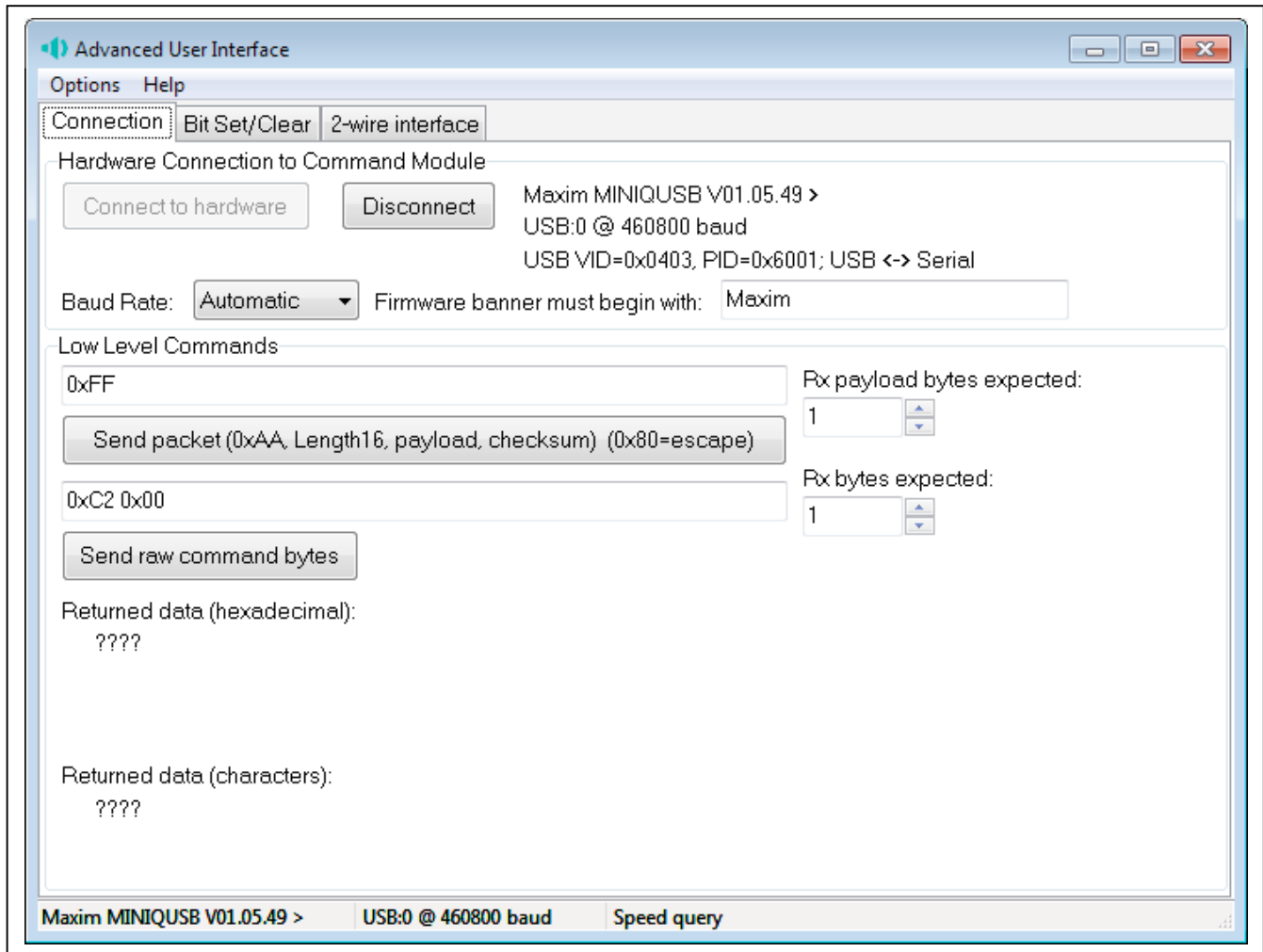

Figure 2. MAX9867 Evaluation Software (Advanced User Interface)

MAX9867 Evaluation Kit

Evaluates: MAX9867

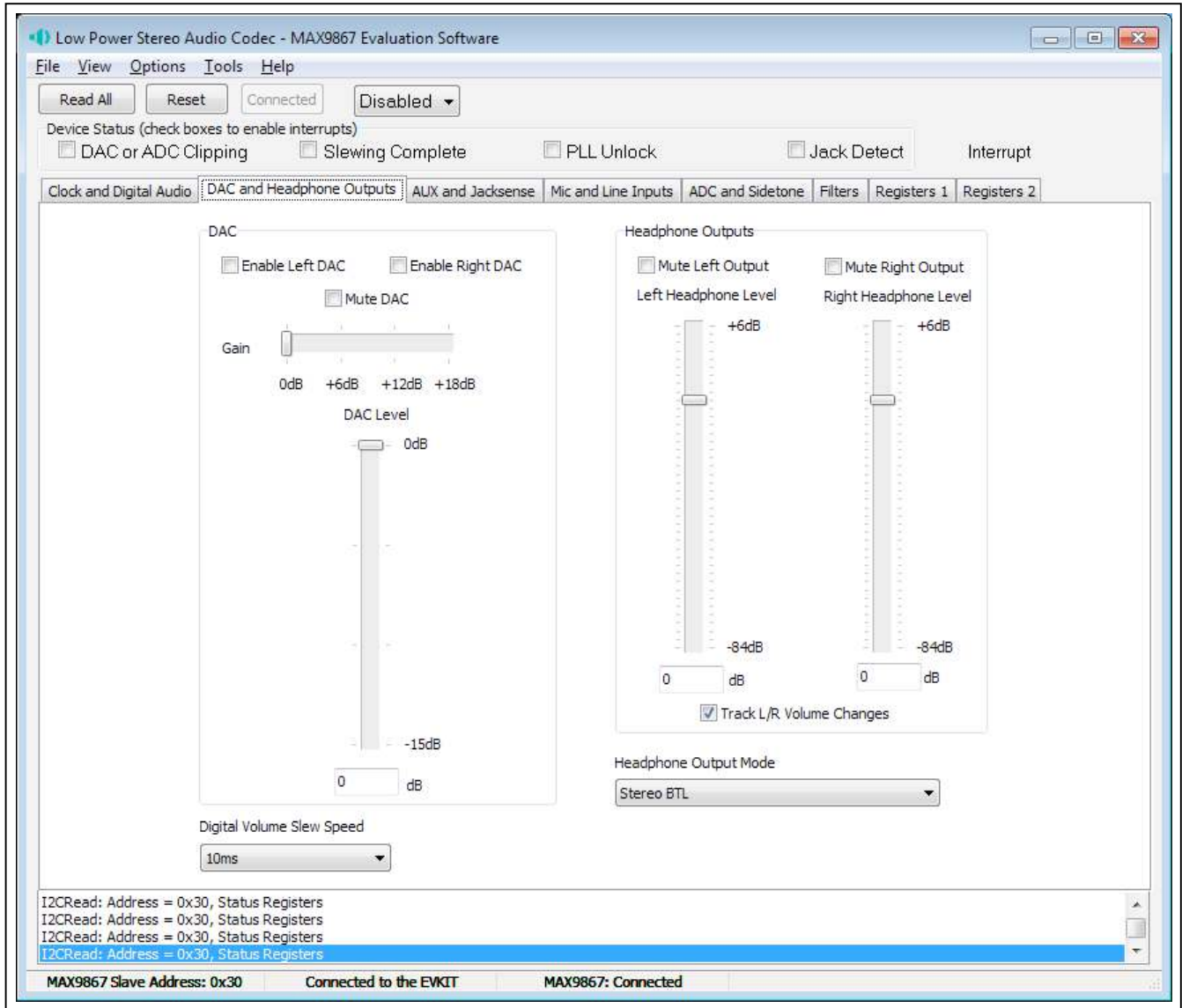

Figure 3. MAX9867 Evaluation Software (DAC and Headphone Outputs Tab)

MAX9867 Evaluation Kit

Evaluates: MAX9867

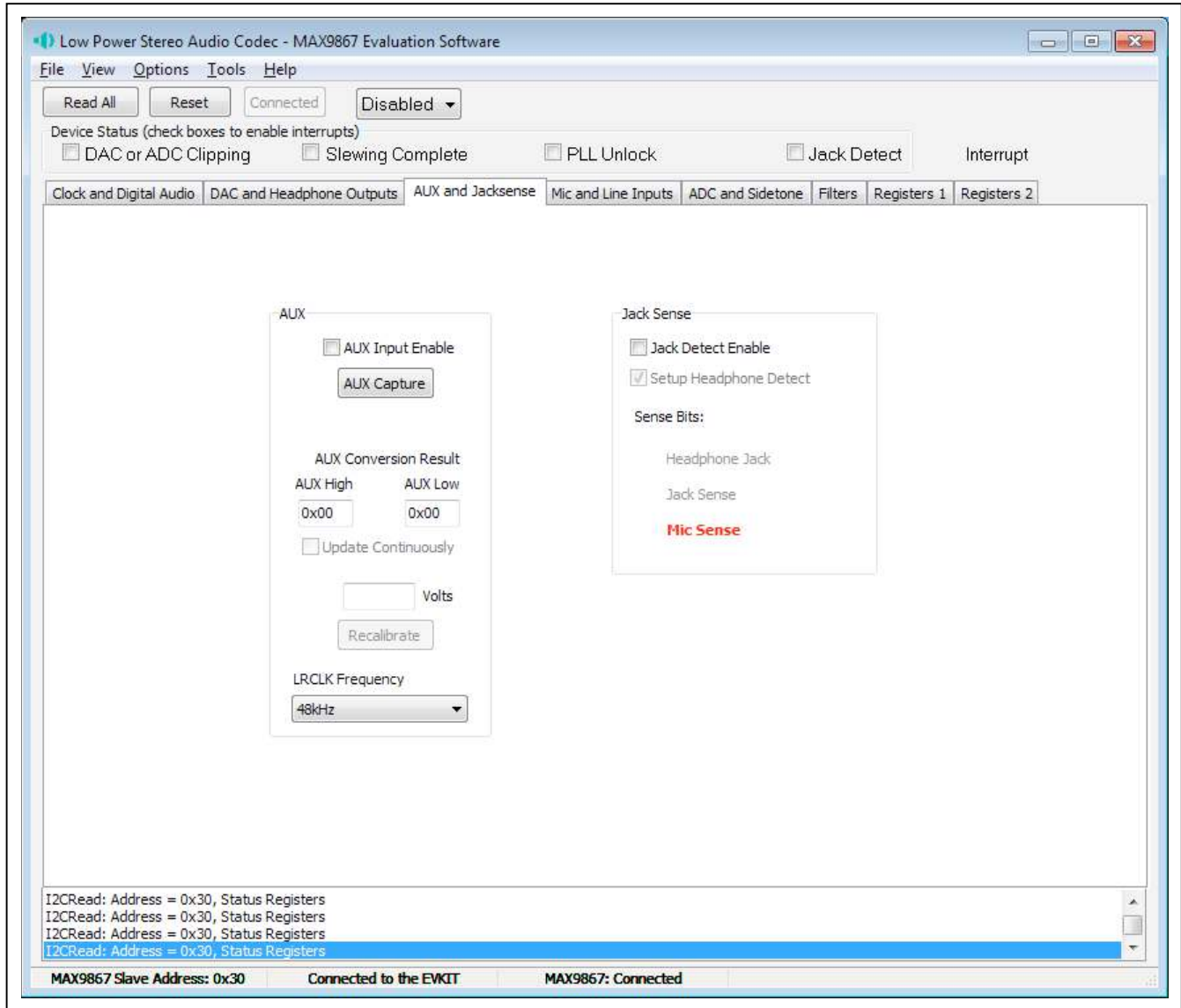

Figure 4. MAX9867 Evaluation Software (AUX and Jacksense Tab)

MAX9867 Evaluation Kit

Evaluates: MAX9867

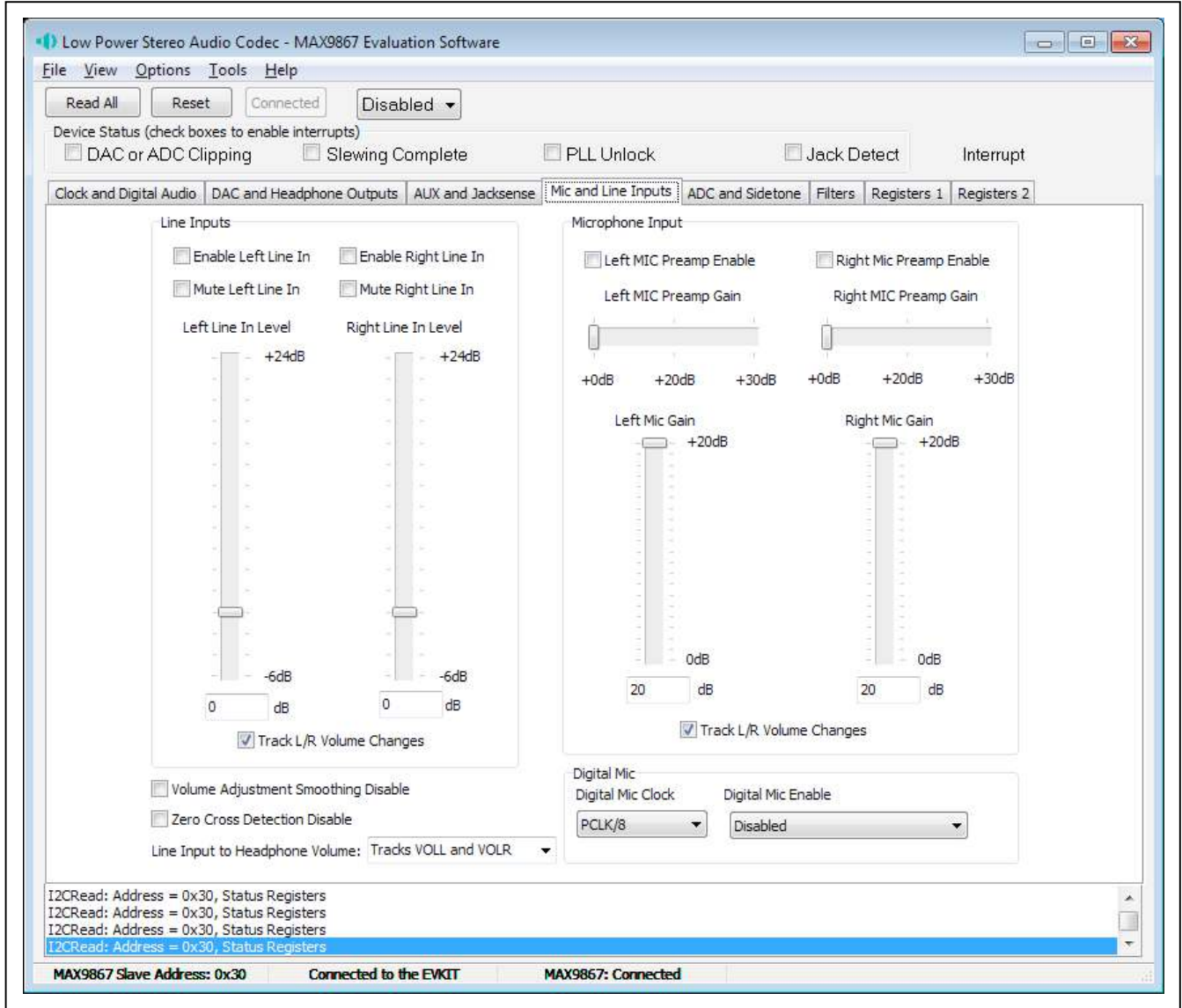

Figure 5. MAX9867 Evaluation Software (Mic and Line Inputs Tab)

MAX9867 Evaluation Kit

Evaluates: MAX9867

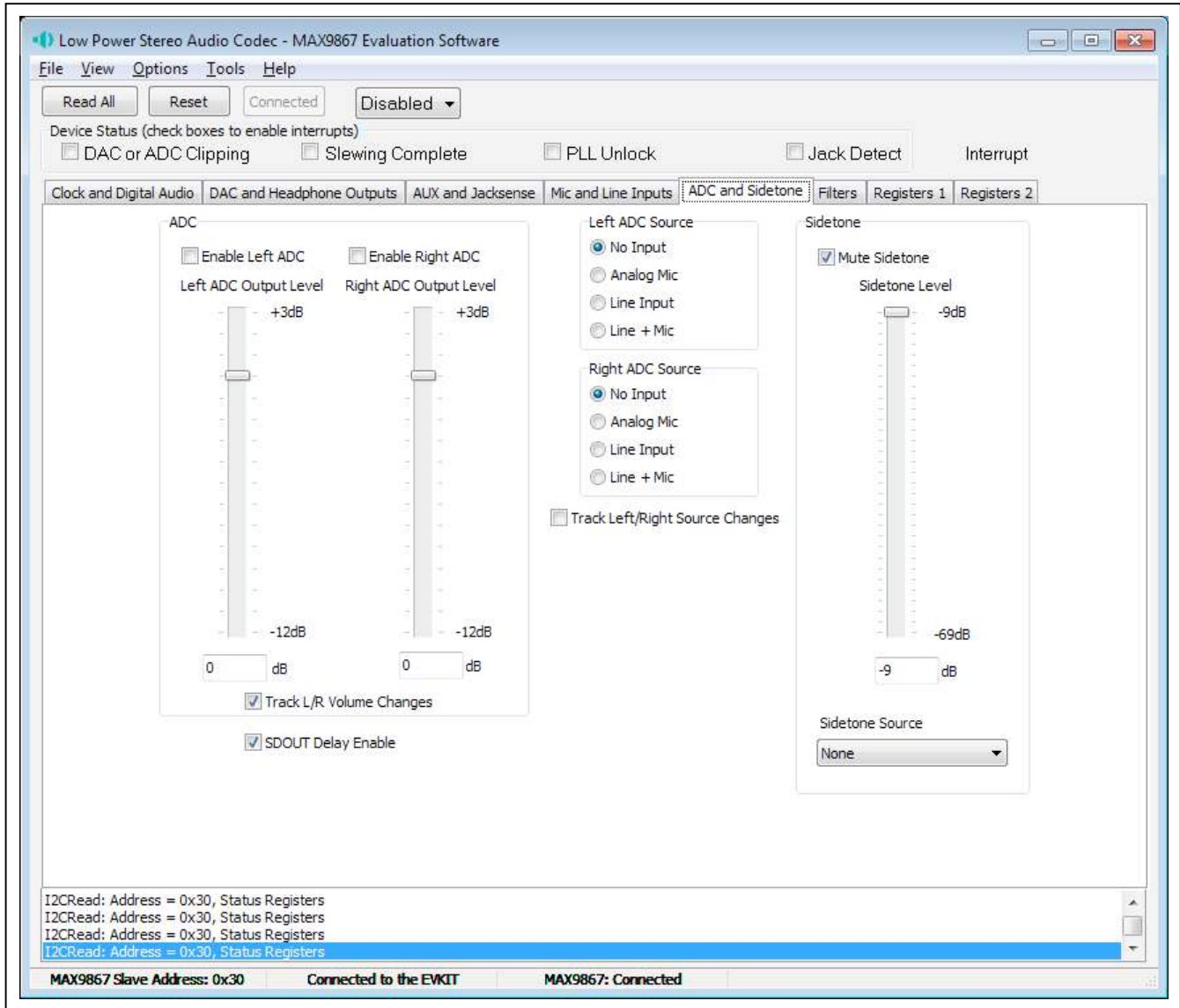

Figure 6. MAX9867 Evaluation Software (ADC and Sidetone Tab)

MAX9867 Evaluation Kit

Evaluates: MAX9867

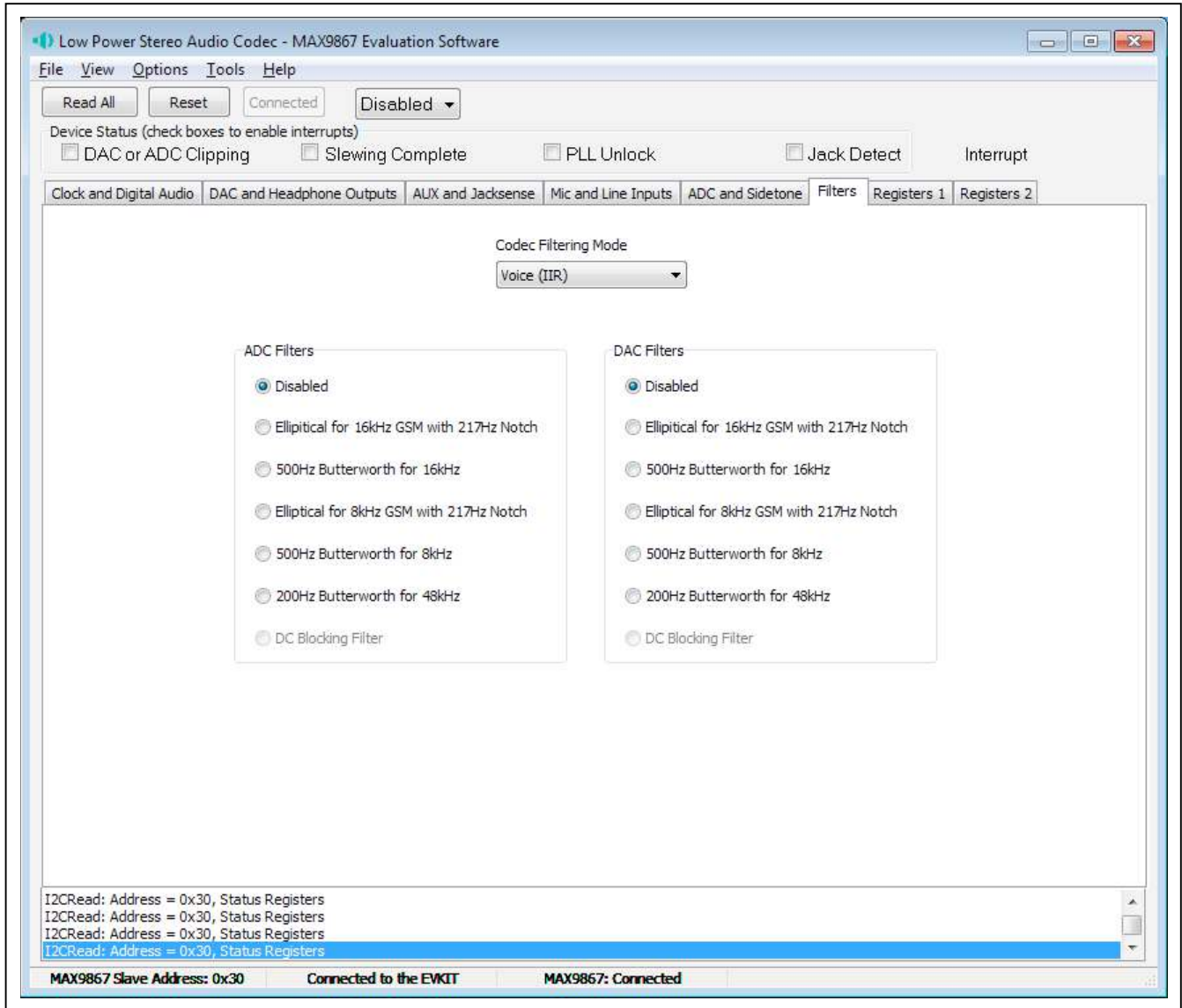

Figure 7. MAX9867 Evaluation Software (Filters Tab)

MAX9867 Evaluation Kit

Evaluates: MAX9867

Low Power Stereo Audio Codec - MAX9867 Evaluation Software

File View Options Tools Help

Read All Reset Connected Disabled

Device Status (check boxes to enable interrupts)

DAC or ADC Clipping Slewing Complete PLL Unlock Jack Detect Interrupt

Clock and Digital Audio DAC and Headphone Outputs AUX and Jacksense Mic and Line Inputs ADC and Sidetone Filters Registers 1 Registers 2

	B7	B6	B5	B4	B3	B2	B1	B0	
Status/Interrupt									
0x00 Status	CLD	SLD	ULK				JDET		0x00
0x01 Jack Status	LSNS	JKSNS	JKMIC						0x20
0x02 Aux High	AUX.15	AUX.14	AUX.13	AUX.12	AUX.11	AUX.10	AUX.9	AUX.8	0x00
0x03 Aux Low	AUX.7	AUX.6	AUX.5	AUX.4	AUX.3	AUX.2	AUX.1	AUX.0	0x00
0x04 Interrupt Enable	ICLD	ISLD	IULK				IJDET		0x00
Clock Control									
0x05 System Clock			PSCLK.1	PSCLK.0	FREQ.3	FREQ.2	FREQ.1	FREQ.0	0x10
0x06 Audio Clock High	PLL	N.14	N.13	N.12	N.11	N.10	N.9	N.8	0x00
0x07 Audio Clock Low	N.7	N.6	N.5	N.4	N.3	N.2	N.1	RLK/N.0	0x00
Digital Audio Interface									
0x08 Interface 1a	MAS	WCI	BCI	DLY	HIZOFF	TDM			0x00
0x09 Interface 1b				LVOLFIX	DMONO	BSEL.2	BSEL.1	BSEL.0	0x00
Digital Filtering									
0x0A Codec Filters	MODE	AVFILT.2	AVFILT.1	AVFILT.0		DVFILT.2	DVFILT.1	DVFILT.0	0x00

I2CRead: Address = 0x30, Status Registers
I2CRead: Address = 0x30, Status Registers
I2CRead: Address = 0x30, Status Registers
I2CRead: Address = 0x30, Status Registers

MAX9867 Slave Address: 0x30 Connected to the EVKIT MAX9867: Connected

Figure 8. MAX9867 Evaluation Software (Registers 1 Tab)

MAX9867 Evaluation Kit

Evaluates: MAX9867

Low Power Stereo Audio Codec - MAX9867 Evaluation Software

File View Options Tools Help

Read All Reset Connected Disabled

Device Status (check boxes to enable interrupts)

DAC or ADC Clipping Slewing Complete PLL Unlock Jack Detect Interrupt

Clock and Digital Audio DAC and Headphone Outputs AUX and Jacksense Mic and Line Inputs ADC and Sidetone Filters Registers 1 **Registers 2**

	B7	B6	B5	B4	B3	B2	B1	B0	
Level Control									
0x0B DAC Gain/Sidetone	DSTS.1	DSTS.0		DVST.4	DVST.3	DVST.2	DVST.1	DVST.0	0x00
0x0C DAC Level		DACM	DACG.1	DACG.0	DACA.3	DACA.2	DACA.1	DACA.0	0x00
0x0D ADC Level	AVL.3	AVL.2	AVL.1	AVL.0	AVR.3	AVR.2	AVR.1	AVR.0	0x33
0x0E Left Line Input Level		LILM			LIGL.3	LIGL.2	LIGL.1	LIGL.0	0x0C
0x0F Right Line Input Level		LIRM			LIGR.3	LIGR.2	LIGR.1	LIGR.0	0x0C
0x10 Left Volume Control		VOLLM	VOLL.5	VOLL.4	VOLL.3	VOLL.2	VOLL.1	VOLL.0	0x09
0x11 Right Volume Control		VOLRM	VOLR.5	VOLR.4	VOLR.3	VOLR.2	VOLR.1	VOLR.0	0x09
0x12 Left Mic Gain		PALEN.1	PALEN.0	PAGAML.4	PAGAML.3	PAGAML.2	PAGAML.1	PAGAML.0	0x00
0x13 Right Mic Gain		PAREN.1	PAREN.0	PAGAMR.4	PAGAMR.3	PAGAMR.2	PAGAMR.1	PAGAMR.0	0x00
Configuration									
0x14 Input	MXINL.1	MXINL.0	MXINR.1	MXINR.0	AUXCAP	AUXGAIN	AUXCAL	AUXEN	0x00
0x15 Microphone	MICCLK.1	MICCLK.0	DIGMIC	DIGMIC					0x00
0x16 Mode	DSLEW	VSEN	ZDEN		JIDENTEN	HPMODE.2	HPMODE.1	HPMODE.0	0x00
Power Management									
0x17 System Shutdown	SFDN	LNLEN	LNREN		DALEN	DAREN	ADLEN	ADREN	0x00

I2CRead: Address = 0x30, Status Registers
I2CRead: Address = 0x30, Status Registers
I2CRead: Address = 0x30, Status Registers
I2CRead: Address = 0x30, Status Registers

MAX9867 Slave Address: 0x30 Connected to the EVKIT MAX9867: Connected

Figure 9. MAX9867 Evaluation Software (Registers 2 Tab)

MAX9867 Evaluation Kit

Evaluates: MAX9867

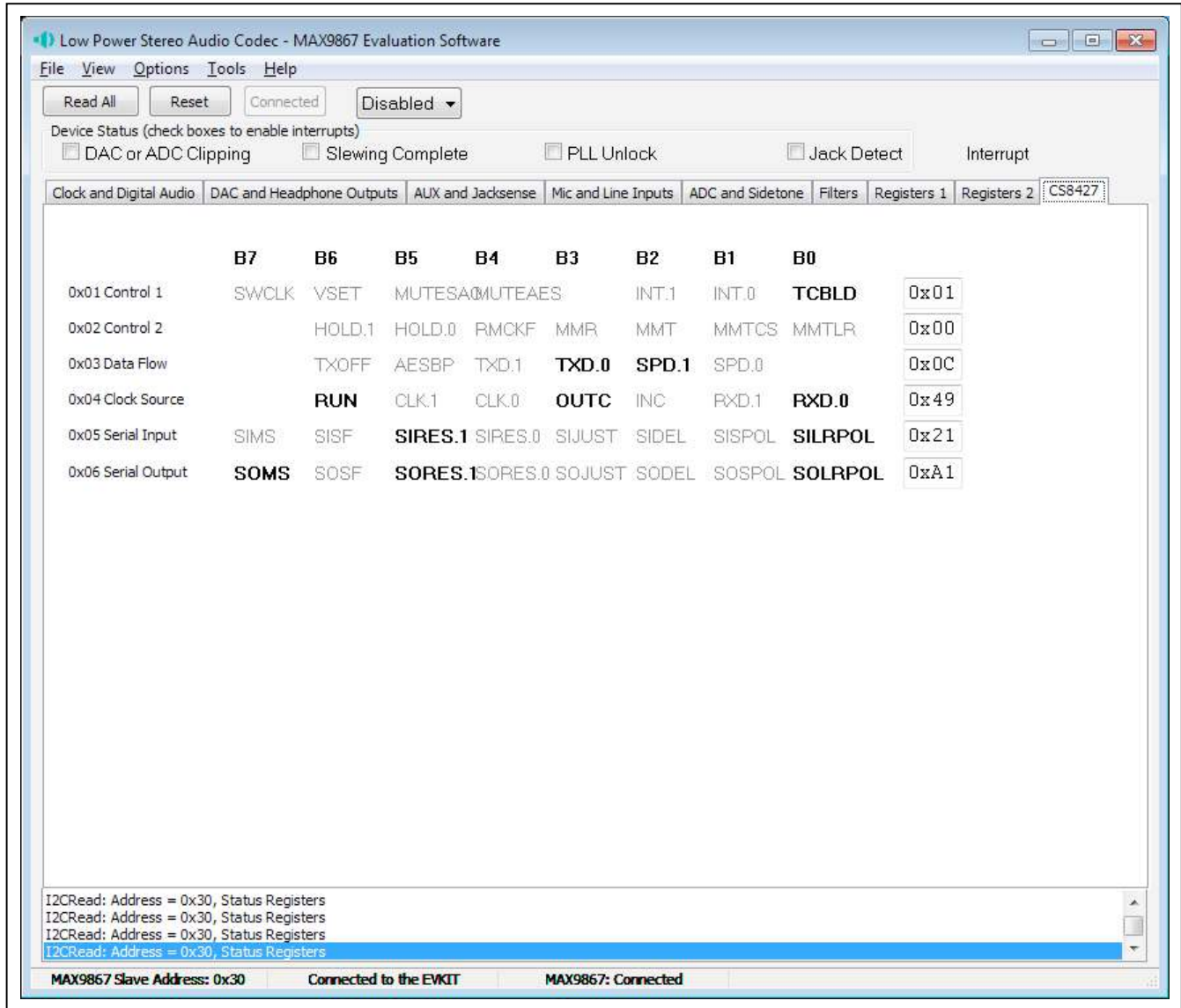

Figure 10. MAX9867 Evaluation Software (CS8427 Tab)

MAX9867 Evaluation Kit

Evaluates: MAX9867

__Detailed Description of Hardware

The MAX9867 EV kit is a complete digital audio evaluation system for the MAX9867 low-power, stereo audio codec. The EV kit provides translation between the digital audio signals and optical S/PDIF signals to allow easy connection with consumer electronics devices. See Table 1 for a description of all EV kit jumper configurations.

Clocking On-Board Clock

The EV kit has one 12.288MHz and one 13MHz clock oscillator on the board to provide flexible master-clock selections for the MAX9867.

Recovered Clock

When the S/PDIF IN has a digital audio input and the S/PDIF transceiver is in operation, the recovered clock from the S/PDIF transceiver can be used as the master clock for the MAX9867.

External Clocks

Connect an external clock source to jumper JU12 pin 2 to drive the MAX9867 MCLK pin without using the on-board oscillator. The user must type in the correct clock frequency in the **MCLK Frequency** edit box.

Jack Detection and DC-Voltage Measurement

The MAX9867 has a JACKSNS/AUX pin that can be configured to either detect the presence/absence of a jack or accurately measure a DC voltage.

To measure a DC voltage, place a shunt on jumper JU7 and apply the DC voltage on the AUX pad. The on-board resistor network (R5, R6) can be used to adjust the input voltage ranges.

To detect the presence or absence of a jack, remove the shunt on jumper JU7 and connect the JACKSNS pad to a proper jack pin. Refer to the MAX9867 IC data sheet for the details of jack-detection functionality.

Microphone Inputs

The MAX9867 features stereo differential microphone inputs that can be connected to either analog or digital microphones.

MICRP and MICRN pins can only connect to an analog microphone. Place shunts on jumpers JU1 and JU3 to use the MAX9867 MICBIAS for microphone biasing. Place a shunt on jumper JU2 to connect MICRN to GND for single-ended microphone input.

MICLP/DIGMICDATA and MICLN/DIGMICCLK pins can connect either to an analog microphone or a digital microphone, but not at the same time. For analog microphone input, remove the shunts on jumpers JU8 and JU9. Place shunts on jumpers JU4 and JU6 to use the MAX9867 MICBIAS for microphone biasing. Place a shunt on jumper JU2 to connect MICLN to GND for single-ended microphone input. For digital microphone input, place shunts on JU8 and JU9 and remove connections on the MICLP and MICLN pads. There are two digital microphones on the EV kit board.

Headphone Outputs

There are two headphone jacks on the EV kit board.

Use J4 for differential or capacitorless output configuration. Remove the shunts on jumpers JU10 and JU11.

Use J5 for single-ended output configuration. Remove the shunts on jumpers JU10 and JU11 for fast turn-on mode. Place the shunts on JU10 and JU11 for clickless mode.

MAX9867 Evaluation Kit

Evaluates: MAX9867

Table 1. Jumper Descriptions (JU1–JU18)

JUMPER	SHUNT POSITON	DESCRIPTION
JU1	Open*	MICRN disconnected from GND
	1-2	MICRN connected to GND through a 2.2kΩ resistor
JU2	Open*	MICRN disconnected from GND
	1 - 2	MICRN connected to GND
JU3	Open*	MICRP disconnected from MICBIAS
	1-2	MICRP connected to MICBIAS through a 2.2kΩ resistor
JU4	Open*	MICLP disconnected from MICBIAS
	1-2	MICLP connected to MICBIAS through a 2.2kΩ resistor
JU5	Open*	MICLN disconnected from GND
	1 - 2	MICLN connected to GND
JU6	Open*	MICLN disconnected from GND
	1-2	MICLN connected to GND through a 2.2kΩ resistor
JU7	Open*	JACKSNS/AUX used for jack detection
	1-2	JACKSNS/AUX used for AUX DC measurement
JU8, JU9	Open*	MICLP/MICLN disconnected from digital microphone
	1-2	MICLP/MICLN connected to digital microphone
JU10	Open*	ROUTN connected to GND through a 1μF capacitor
	1-2	ROUTN disconnected from GND
JU11	Open*	LOUTN connected to GND through a 1μF capacitor
	1-2	LOUTN disconnected from GND
JU12, JU13	2-3* (all rows)	MAX9867 connected to on-board I ² S and I ² C interfaces
	Open	MAX9867 I ² S and I ² C interfaces available for user-supplied equipment
JU14	1-2*	MAX9867 DVDD connected to on-board 1.8V supply
	Open	MAX9867 DVDD applied externally on DVDD pad
JU15	1-2*	MAX9867 AVDD connected to on-board 1.8V supply
	Open	MAX9867 AVDD applied externally on AVDD pad
JU16	1-2*	MAX9867 PDD connected to on-board 1.8V supply
	Open	MAX9867 PVDD applied externally on PVDD pad
JU17	1-2*	MAX9867 DVDDIO connected to on-board 3.3V supply
	Open	MAX9867 DVDDIO applied externally on DVDDIO pad
JU18	1-2*	CS8427 powered by 5V USB supply
	Open	CS8427 powered by external supply on CS8427_5V pad

*Default position.

MAX9867 Evaluation Kit

Evaluates: MAX9867

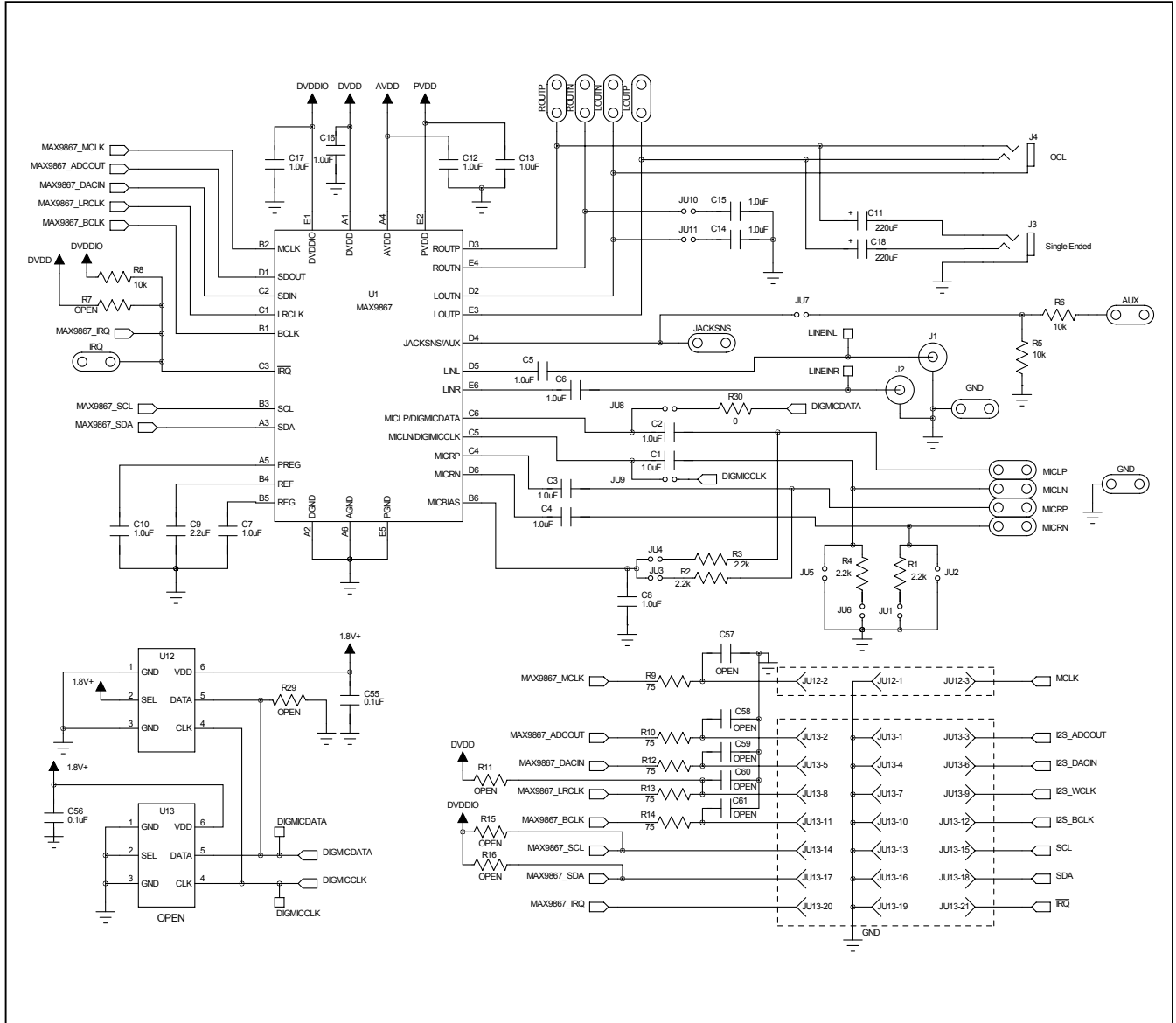

Figure 11a. MAX9867 EV Kit Schematic (Sheet 1 of 4)

MAX9867 Evaluation Kit

Evaluates: MAX9867

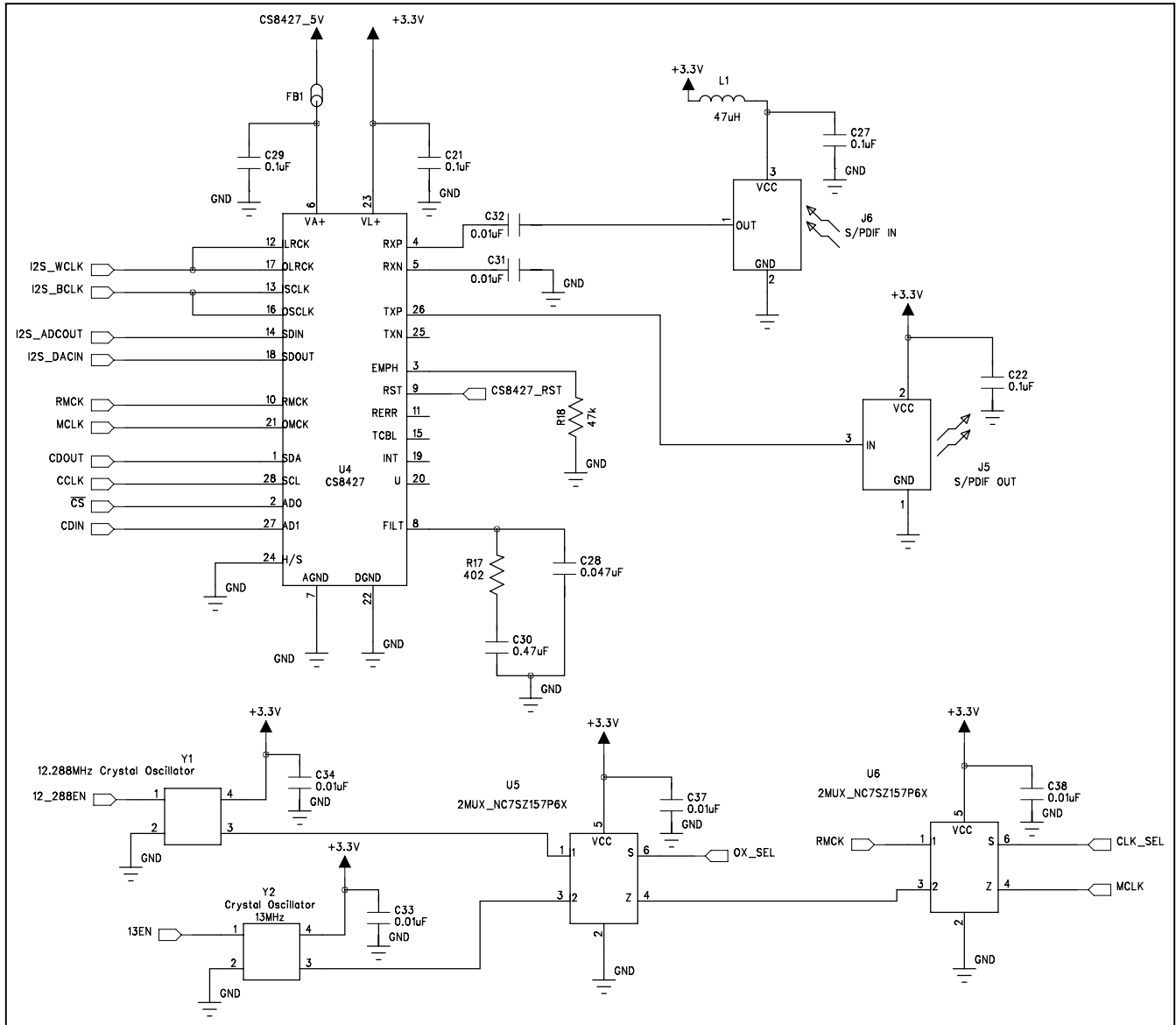

Figure 11b. MAX9867 EV Kit Schematic (Sheet 2 of 4)

MAX9867 Evaluation Kit

Evaluates: MAX9867

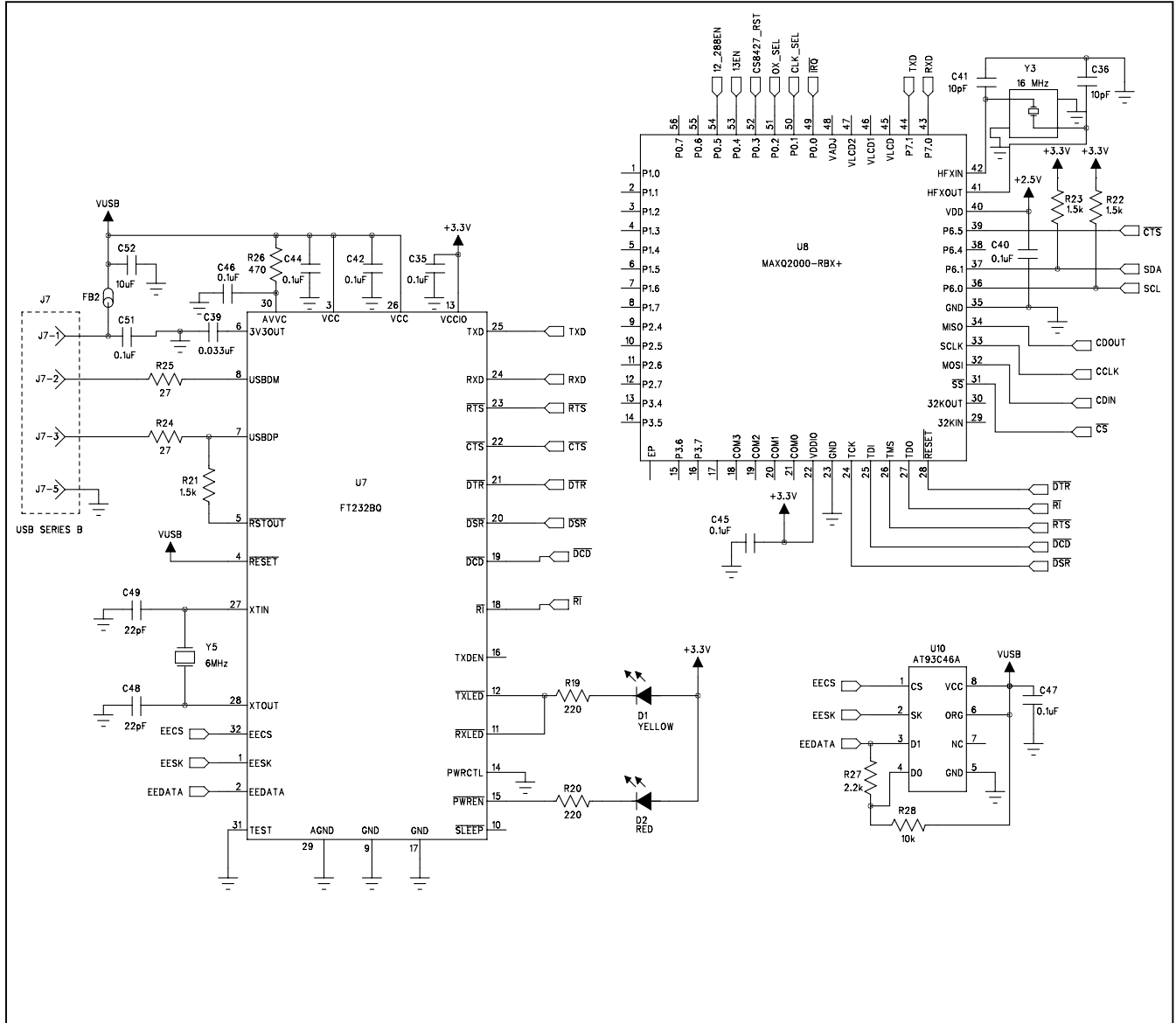

Figure 11c. MAX9867 EV Kit Schematic (Sheet 3 of 4)

MAX9867 Evaluation Kit

Evaluates: MAX9867

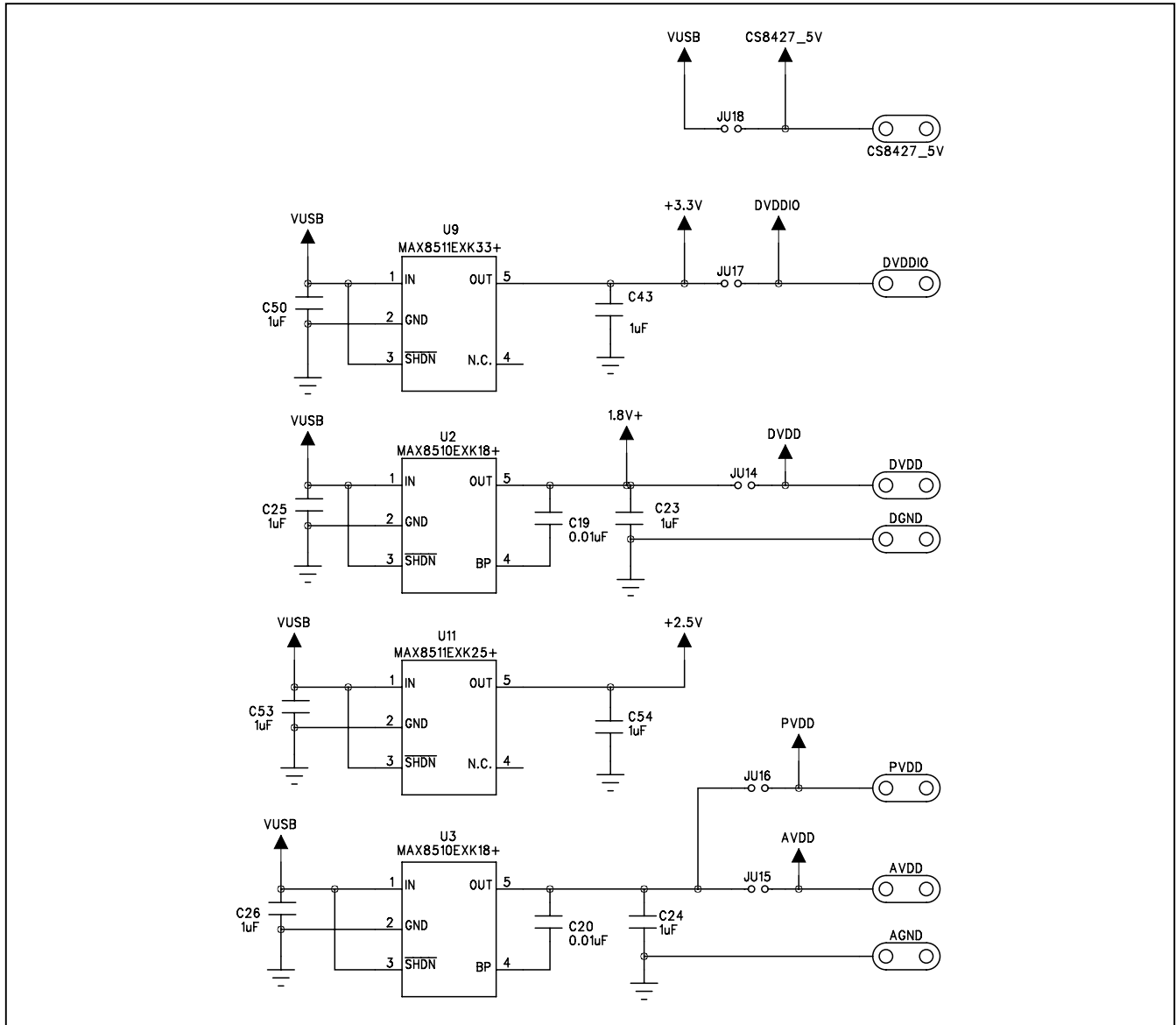

Figure 11d. MAX9867 EV Kit Schematic (Sheet 4 of 4)

MAX9867 Evaluation Kit

Evaluates: MAX9867

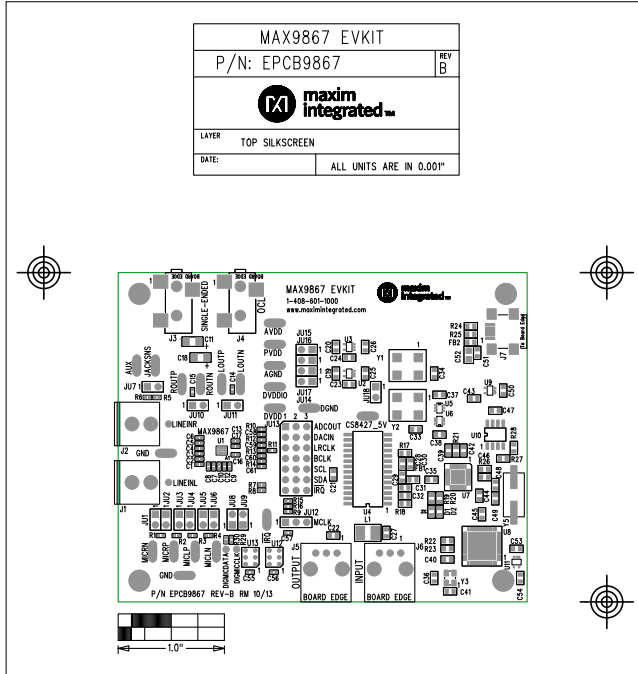

Figure 12. MAX9867 EV Kit Component Placement Guide—Component Side

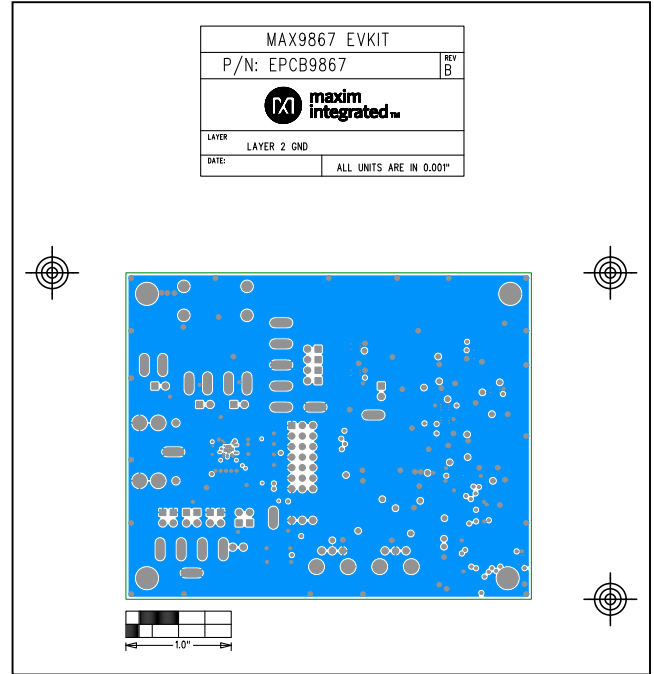

Figure 14. MAX9867 EV Kit PCB Layout—Inner Layer 2

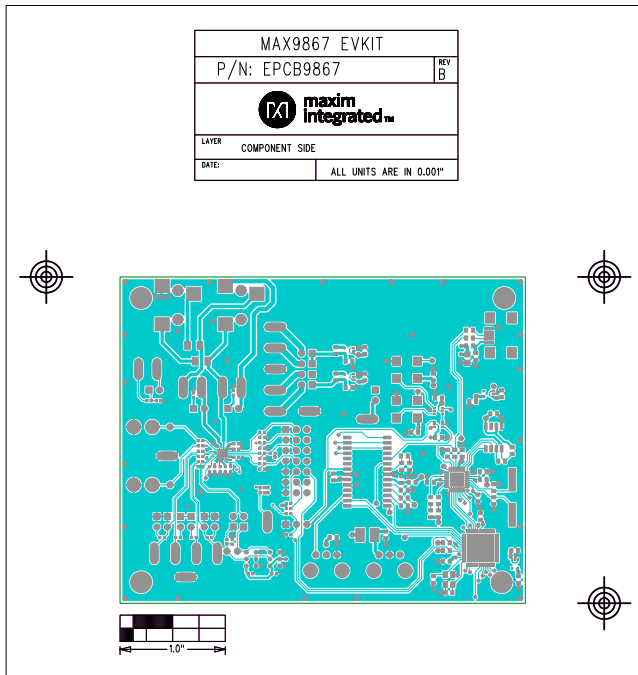

Figure 13. MAX9867 EV Kit PCB Layout—Component Side

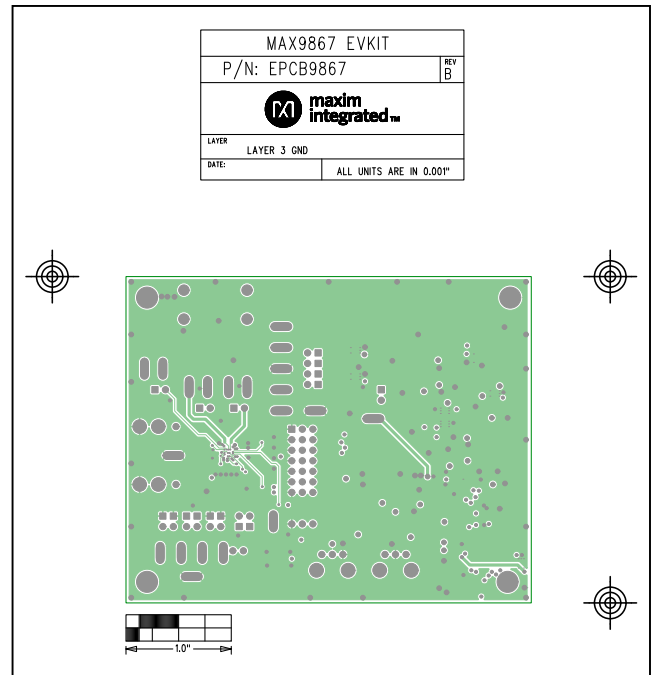

Figure 15. MAX9867 EV Kit PCB Layout—Inner Layer 3

MAX9867 Evaluation Kit

Evaluates: MAX9867

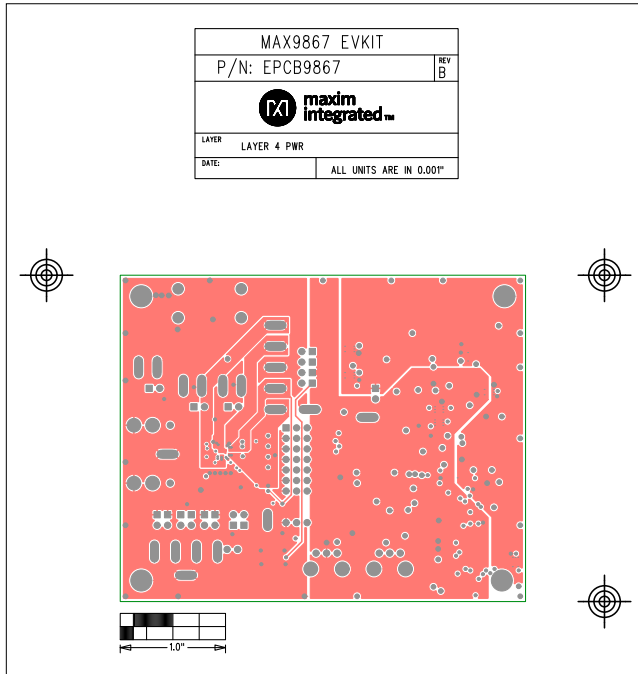

Figure 16. MAX9867 EV Kit PCB Layout—Inner Layer 4

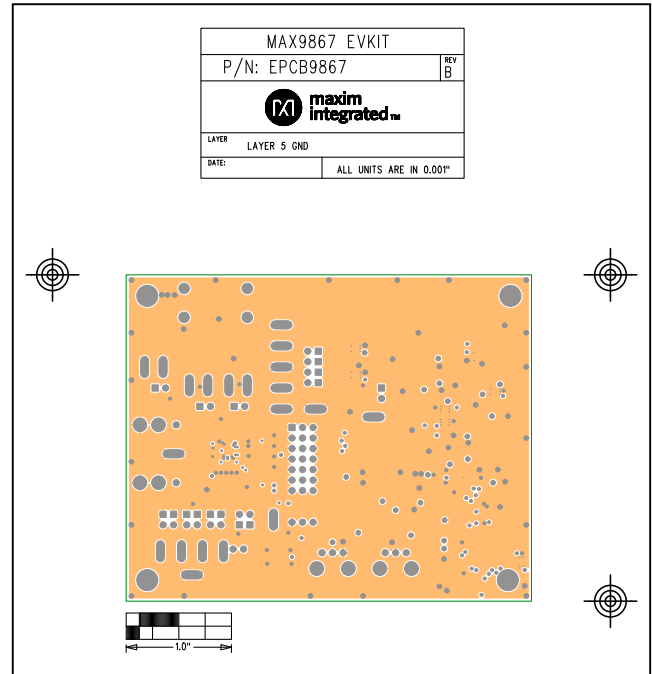

Figure 17. MAX9867 EV Kit PCB Layout—Inner Layer 5

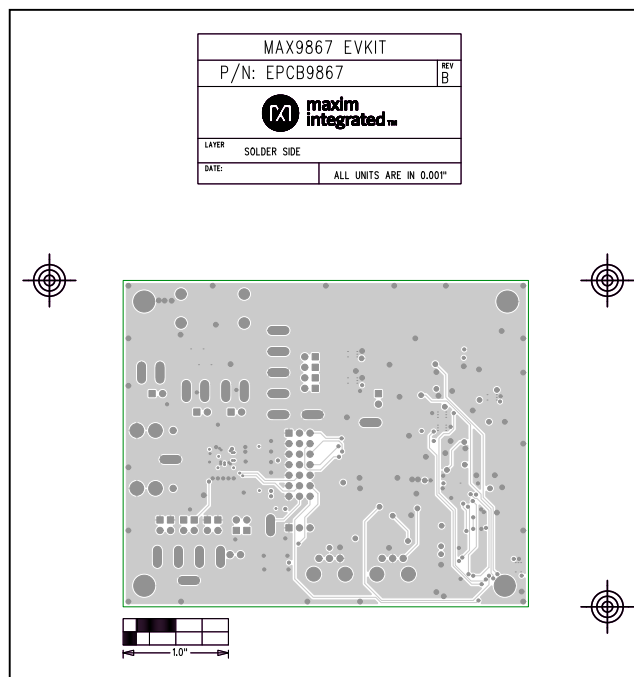

Figure 18. MAX9867 EV Kit PCB Layout—Solder Side

MAX9867 Evaluation Kit

Evaluates: MAX9867

Revision History

REVISION NUMBER	REVISION DATE	DESCRIPTION	PAGES CHANGED
0	12/09	Initial release	—
1	7/16	Updated <i>Quick Start</i> section, Figure 1, <i>Tools Menu</i> section, Figures 2–10, 11a, 12–18	4–15, 18, 22, 23



Maxim Integrated cannot assume responsibility for use of any circuitry other than circuitry entirely embodied in a Maxim Integrated product. No circuit patent licenses are implied. Maxim Integrated reserves the right to change the circuitry and specifications without notice at any time. The parametric values (min and max limits) shown in the Electrical Characteristics table are guaranteed. Other parametric values quoted in this data sheet are provided for guidance.