

Click [here](#) for production status of specific part numbers.

MAX33053E/MAX33054E

+3.3V, 2Mbps CAN Transceiver with $\pm 65V$ Fault Protection, $\pm 25V$ CMR, and $\pm 25kV$ ESD

General Description

The MAX33053E and MAX33054E are +3.3V CAN (Control Area Network) transceivers with integrated protection for industrial applications. These devices have extended $\pm 65V$ fault protection for equipment where overvoltage protection is required. It also incorporates high $\pm 25kV$ ESD HBM and an input common mode range (CMR) of $\pm 25V$, exceeding the ISO 11898 specification of $-2V$ to $+7V$. This makes these parts well-suited for applications that are in electrically noisy environments where the ground planes are shifting relative to each other. This family features a variety of options to address common CAN application requirements; logic-level supply input V_L for interfacing with 1.62V to 3.6V logic, low-current standby mode, silent-mode to disable the transmitter, and a slow slew rate to minimize EMI.

These devices operate at a high-speed CAN data rate, allowing up to 2Mbps on small networks. Maximum speed on large networks may be limited by the number of nodes in a network, the type of cabling used, stub length, and other factors. These transceivers include a dominant timeout to prevent bus lockup caused by controller error or by a fault on the TXD input. When TXD remains in the dominant state (low) for longer than T_{DOM} , the driver is switched to the recessive state, releasing the bus. The MAX33053E features an S pin where it enables and disables the transmitter for applications where you need the transceiver to receive only. The MAX33054E features a STBY pin for 3 modes of operation; standby mode for low-current consumption, normal high-speed mode, or a slow slew rate mode when an external 26.1k Ω is connected between ground and STBY pin.

The MAX33053E and MAX33054E are available in a standard 8-pin SOIC package and operate over the $-40^{\circ}C$ to $+125^{\circ}C$ temperature range.

Applications

- Programmable Logic Controller
- Industrial Automation
- Building Automation
- Instrumentation
- Smart Grid Equipment
- Drone
- Motor Control

Benefits and Features

- Integrated Protection Increases Robustness
 - $\pm 65V$ Fault Tolerant CANH and CANL
 - $\pm 25kV$ ESD HBM (Human Body Model)
 - $\pm 25V$ Extended Common Mode Input Range (CMR)
 - Transmitter Dominant Timeout Prevents Lockup
 - Short-Circuit Protection
 - Thermal Shutdown
- Family Provides Flexible Design Options
 - Slow Slew Rate to minimize EMI
 - Silent Mode S Disables Transmitter
 - STBY Input for Low-Current Mode, Slow Slew Rate
 - 1.62V to 3.6V Logic-Supply (V_L) Range
- High-Speed Operation of Up to 2Mbps
- Operating Temperature Range of $-40^{\circ}C$ to $+125^{\circ}C$ in 8-pin SOIC Package

Ordering Information appears at end of data sheet.

Simplified Block Diagram

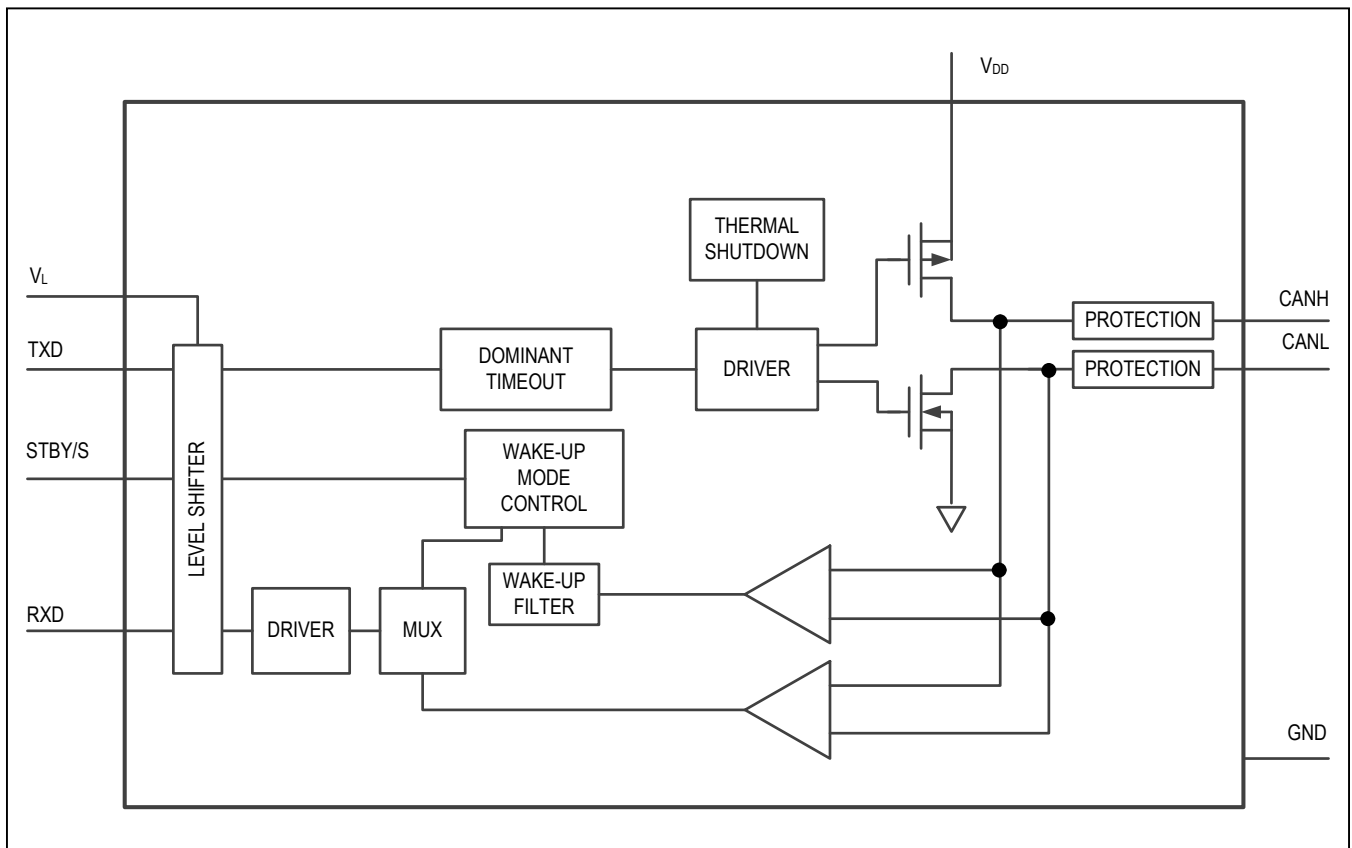

Absolute Maximum Ratings

V_{DD}.....-0.3V to +4.0V
 CANH or CANL (Continuous).....-65V to +65V
 TXD, STBY, S.....-0.3V to +4.0V
 RXD.....-0.3V to (V_L + 0.3)V
 VL.....-0.3V to (V_{DD} + 0.5V)
 Short-Circuit Duration.....Continuous
 Continuous Power Dissipation:
 Single Layer Board
 (T_A = +70°C, derate 5.9mW/°C above +70°C.).....470.6mW

Multilayer Board
 (T_A = +70°C, derate 7.6mW/°C above +70°C.).....606.1mW
 Operating Temperature Range.....-40°C to 125°C
 Junction Temperature.....+150°C
 Storage Temperature Range.....-60°C to +150°C
 Soldering Temperature (reflow).....+260°C
 Lead Temperature (soldering, 10sec).....+300°C

Stresses beyond those listed under "Absolute Maximum Ratings" may cause permanent damage to the device. These are stress ratings only, and functional operation of the device at these or any other conditions beyond those indicated in the operational sections of the specifications is not implied. Exposure to absolute maximum rating conditions for extended periods may affect device reliability.

PACKAGE INFORMATION

8 SOIC

PACKAGE CODE	S8+4
Outline Number	21-0041
Land Pattern Number	90-0096
THERMAL RESISTANCE, SINGLE-LAYER BOARD:	
Junction-to-Ambient (θ _{JA})	170
Junction-to-Case (θ _{JC})	40
THERMAL RESISTANCE, FOUR-LAYER BOARD:	
Junction-to-Ambient (θ _{JA})	132
Junction-to-Case (θ _{JC})	38

For the latest package outline information and land patterns (footprints), go to www.maximintegrated.com/packages. Note that a "+", "#", or "-" in the package code indicates RoHS status only. Package drawings may show a different suffix character, but the drawing pertains to the package regardless of RoHS status.

Package thermal resistances were obtained using the method described in JEDEC specification JESD51-7, using a four-layer board. For detailed information on package thermal considerations, refer to www.maximintegrated.com/thermal-tutorial.

MAX33053E/MAX33054E

+3.3V, 2Mbps CAN Transceiver with ±65V Fault Protection, ±25V CMR, and ±25kV ESD

Package Information (continued)

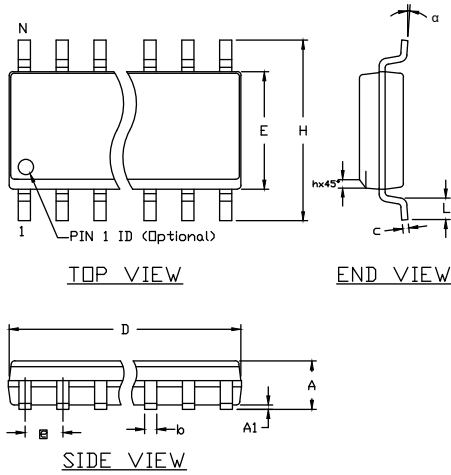

COMMON DIMENSIONS						
SYMBOL	INCHES			MM		
	MIN.	TYP.*	MAX.	MIN.	TYP.*	MAX.
A	.053	.061	.069	1.35	1.55	1.75
A1	.004	.007	.010	0.10	0.18	0.25
b	.014	.017	.019	0.35	0.42	0.49
c	.007	.009	.010	0.19	0.22	0.25
E	.150	.154	.157	3.80	3.90	4.00
e	.050 BSC			1.27 BSC		
H	.228	.236	.244	5.80	6.00	6.20
L	.016	.033	.050	0.40	0.84	1.27
α	0°	4°	8°	0°	4°	8°
h	0.01	0.015	0.019	0.25	0.38	0.5

* Typical value provided for reference only. This is not a specification.

VARIATION A						
SYMBOL	INCHES			MM		
	MIN.	TYP.*	MAX.	MIN.	TYP.*	MAX.
D	.189	.193	.197	4.80	4.90	5.00
N	8					
MS012	AA					
PKG. CODE	S8-2, S8-2C, S8-4, S8-5, S8-6F, S8-7F, S8-8F, S8-10F, S8-11F, S8-16F, S8-19F, S8-20, S8-21, S8MK-1, S8M-5, S8MS-22, S8-22, S8-23, S8MS-23					

VARIATION B						
SYMBOL	INCHES			MM		
	MIN.	TYP.*	MAX.	MIN.	TYP.*	MAX.
D	.337	.341	.344	8.55	8.65	8.75
N	14					
MS012	AB					
PKG. CODE	S14-1, S14-4, S14-5, S14-6, S14M-4, S14M-5, S14M-6, S14M-7					

VARIATION C						
SYMBOL	INCHES			MM		
	MIN.	TYP.*	MAX.	MIN.	TYP.*	MAX.
D	.386	.390	.394	9.80	9.90	10.00
N	16					
MS012	AC					
PKG. CODE	S16-1, S16-3, S16-5, S16-6, S16-8, S16-7F, S16-9F, S16-10F, S16M-3, S16M-6, S16M-11, S16MS-12					

NOTES:

- ALL DIMENSIONS ARE IN MILLIMETERS UNLESS OTHERWISE SPECIFIED.
- MATERIAL MUST COMPLY WITH BANNED AND RESTRICTED SUBSTANCES SPEC # 10-0131.
- DIMENSIONS D AND E DO NOT INCLUDE MOLD PROTRUSION. ALLOWABLE MOLD PROTRUSION IS 0.15 MM (.006") PER SIDE.
- LEADS TO BE COPLANAR WITHIN 0.10mm (.004").
- MEETS JEDEC MS012
- ALL DIMENSIONS APPLY TO BOTH LEADED (-) AND PbFREE (+) PKG. CODES.

-DRAWING NOT TO SCALE-

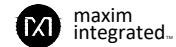

TITLE:
PACKAGE OUTLINE,
8L, 14L, 16L SOIC .150 INCH

APPROVAL KAI LIU	DOCUMENT CONTROL NO. 21-0041	REV. Q	1/1
---------------------	---------------------------------	-----------	-----

Electrical Characteristics

(($V_{DD} = 3.0V$ to $3.6V$, $V_L = 1.62V$ to V_{DD} , $R_L = 60\Omega$, $C_L = 15pF$, $T_A = T_{MIN}$ to T_{MAX} , unless otherwise specified. Typical values are at $V_{DD} = 3.3V$, $V_L = 1.8V$, and $T_A = +25^\circ C$, unless otherwise specified.) (Note 1))

PARAMETER	SYMBOL	CONDITIONS		MIN	TYP	MAX	UNITS
POWER							
Supply Voltage	V_{DD}			3.0		3.6	V
Logic Supply Voltage	V_L			1.62		V_{DD}	V
Dominant Supply Current	I_{DD_DOM}	$V_{DD} = 3.3V$, TXD = 0V	No load		4.5	8	mA
			$R_L = 60\Omega$		36	50	
Recessive Supply Current	I_{DD_REC}	$V_{DD} = TXD = 3.3V$	No load		3.6		mA
			CANH shorted to CANL		3.6		
Standby Supply Current	I_{STBY}	STBY = logic high			33		μA
Silent Supply Current	I_S	S = logic-high			2.5		mA
Logic Supply Current	I_L	RXD = open	$V_L = 3.3V$		40		μA
			$V_L = 1.8V$		22		
UVLO Threshold Rising	V_{UVLO_R}	V_{DD} rising				2.7	V
UVLO Threshold Falling	V_{UVLO_F}	V_{DD} falling		1.6			V
FAULT PROTECTION							
ESD Protection (CANH, CANL to GND)	Human Body Model (HBM)				±25		kV
	Air-Gap ISO 10605, IEC 61000-4-2				±15		
	Contact ISO 10605, IEC 61000-4-2				±10		
ESD Protection (All Other Pins)	Human Body Model (HBM)				±4		kV
Fault Protection Range	V_{FP}	CANH or CANL to GND		-65		+65	V
Thermal Shutdown	T_{SHDN}				+160		$^\circ C$
Thermal Shutdown Hysteresis	T_{HYST}				+20		$^\circ C$
LOGIC INTERFACE (RXD, TXD, STBY, S)							
Input High Voltage	V_{IH}			$0.7 \times V_L$			V
Input Low Voltage	V_{IL}	$2.25V \leq V_L \leq 3.6V$				0.8	V
		$1.62V \leq V_L \leq 2.25V$				0.6	
TXD Input Pullup Resistance	R_{PU_TXD}			100		250	k Ω
STBY, S Input Pullup Resistance	R_{PU_S}			100		250	k Ω
Output High Voltage	V_{OH}	Sourcing 4mA		$V_L - 0.5$			V
Output Low Voltage	V_{OL}	Sinking 4mA				0.4	V
CAN BUS DRIVER							
Bus Output Voltage (Dominant)	V_{O_DOM}	$t < t_{DOM}$, TXD = 0V, $R_L = 60\Omega$	CANH	2.25		V_{DD}	V
			CANL	0.5		1.25	
Bus Output Voltage (Recessive)	V_{O_REC}	TXD = V_L , No load	CANH	1		2	V
			CANL	1		2	

Electrical Characteristics (continued)

(($V_{DD} = 3.0V$ to $3.6V$, $V_L = 1.62V$ to V_{DD} , $R_L = 60\Omega$, $C_L = 15pF$, $T_A = T_{MIN}$ to T_{MAX} , unless otherwise specified. Typical values are at $V_{DD} = 3.3V$, $V_L = 1.8V$, and $T_A = +25^\circ C$, unless otherwise specified.) (Note 1))

PARAMETER	SYMBOL	CONDITIONS		MIN	TYP	MAX	UNITS
Bus Output Differential Voltage (Dominant)	V_{OD_DOM}	TXD = 0V, $R_L = 60\Omega$	$R_{CM} = 1k\Omega$, $-5V \leq V_{CM} \leq V_{DD}$, Figure 1	1.5		3	V
			$R_{CM} = \text{open}$	1.5		3	
Output Voltage Standby	V_{O_STBY}	$V_{TXD} = STBY = V_L$, no load		40		120	mV
Bus Output Differential Voltage (Recessive)	V_{OD_REC}	TXD = V_L	$R_L = 60\Omega$	-10		+10	mV
			No load	-50		+50	
Short-Circuit Current	I_{SC_CANH}	TXD = 0V, CANH = -65V			2	5	mA
	I_{SC_CANL}	TXD = 0V, CANL = +65V			2	5	
RECEIVER							
Common Mode Input Range	V_{CM}	CANH or CANL to GND, RXD output valid		-25		+25	V
Common Mode Input Range Standby Mode	V_{CM_S}	CANH or CANL to GND, RXD output valid		-12		+12	V
Input Differential Voltage (Dominant)	V_{ID_DOM}	$-25V \leq V_{CM} \leq 25V$, TXD = V_L				0.9	V
Input Differential Voltage (Recessive)	V_{ID_REC}	$-25V \leq V_{CM} \leq 25V$, TXD = V_L		0.5			V
Standby Input Differential Voltage (Dominant)	V_{ID_SDOM}	$-12V \leq V_{CM} \leq +12V$, TXD = V_L				1.15	V
Standby Input Differential Voltage (Recessive)	V_{ID_SREC}	$-12V \leq V_{CM} \leq +12V$, TXD = V_L		0.45			V
Input Differential Hysteresis	V_{ID_HYS}	$-25V \leq V_{CM} \leq 25V$			90		mV
Input Resistance	R_{IN}	TXD = V_L		10		50	k Ω
Differential Input Resistance	R_{IN_DIFF}	TXD = V_L		20		100	k Ω
Input Capacitance	C_{IN}	TXD = V_L (Note 2)			62	110	pF
Differential Input Capacitance	C_{IN_DIFF}	TXD = V_L (Note 2)			31	55	pF
Input Leakage Current	I_{LKG}	$V_{DD} = V_L = 0V$	CANH = CANL = 3.3V		100	220	μA
SWITCHING							
Driver Rise Time	t_R	$R_L = 60\Omega$, $C_L = 100pF$, R_{CM} is open, Figure 1			13		ns
Driver Fall Time	t_F	$R_L = 60\Omega$, $C_L = 100pF$, R_{CM} is open, Figure 1			21		ns
Slow Slew Driver Rise Time	t_{SSR}	$R_L = 60\Omega$, $C_{LD} = 100pF$, R_{CM} is open, Figure 1			315		ns
Slow Slew Driver Fall Time	t_{SSF}	$R_L = 60\Omega$, $C_{LD} = 100pF$, R_{CM} is open, Figure 1			140		ns
TXD to RXD Loop Delay	t_{LOOP}	$R_L = 60\Omega$, Dominant-to Recessive and Recessive-to-Dominant, Figure 2			85	140	ns
TXD Propagation Delay (Recessive to Dominant)	t_{ONTXD}	$R_L = 60\Omega$, $C_L = 100pF$, R_{CM} is open, $V_{DD} = 3.3V$, Figure 1			43	60	ns
TXD Propagation Delay (Dominant to Recessive)	t_{OFFTXD}	$R_L = 60\Omega$, $C_L = 100pF$, R_{CM} is open, $V_{DD} = 3.3V$, Figure 1			40	60	ns
RXD Propagation Delay (Recessive to Dominant)	t_{ONRXD}	$C_L = 15pF$, $V_{DD} = 3.3V$, Figure 3			30	85	ns

Electrical Characteristics (continued)

((V_{DD} = 3.0V to 3.6V, V_L = 1.62V to V_{DD}, R_L = 60Ω, C_L = 15pF, T_A = T_{MIN} to T_{MAX}, unless otherwise specified. Typical values are at V_{DD} = 3.3V, V_L = 1.8V, and T_A = +25°C, unless otherwise specified.) (Note 1))

PARAMETER	SYMBOL	CONDITIONS	MIN	TYP	MAX	UNITS
RXD Propagation Delay (Dominant to Recessive)	t _{OFFRXD}	C _L = 15pF, Figure 3		40	85	ns
TXD-Dominant Timeout	t _{DOM}	Figure 4	1.3		4.3	ms
Wake-Up Time	t _{WAKE}	Figure 5		2.3		μs
Standby Propagation Delay	t _{PLH_STBY}	C _L = 15pF		300		ns
Standby to Normal Mode Delay	t _{D_SN}	C _L = 15pF		20		μs
Normal to Standby Dominant Delay	t _{D_NS}	C _L = 15pF		30		μs

Note 1: All units are 100% production tested at T_A = +25°C. Specifications over temperature are guaranteed by design.

Note 2: Not production tested. Guaranteed at T_A = +25°C.

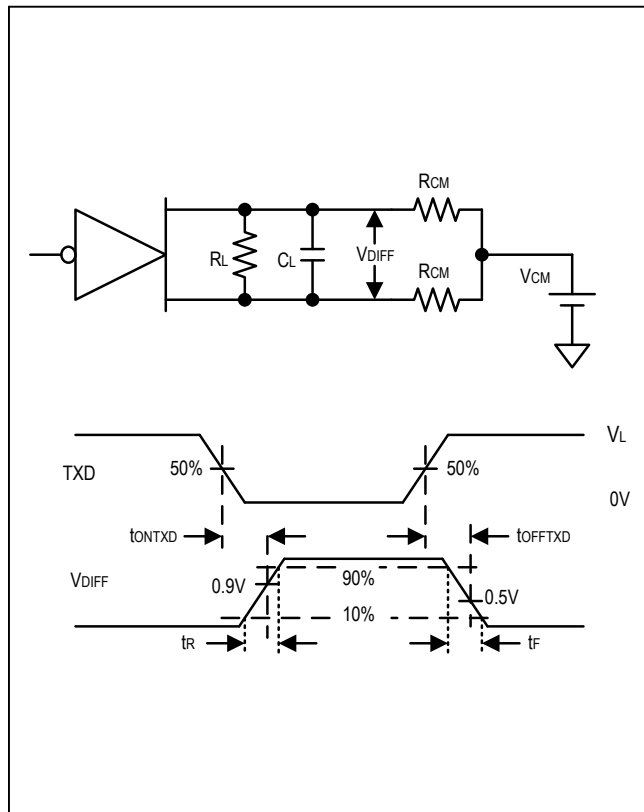

Figure 1. Transmitter Test Circuit and Timing Diagram

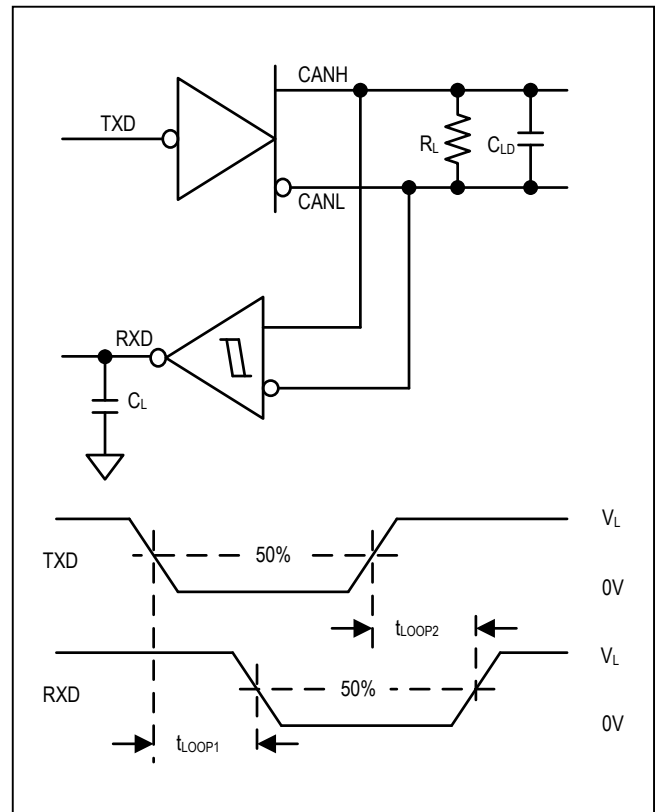

Figure 2. TXD to RXD Loop Delay

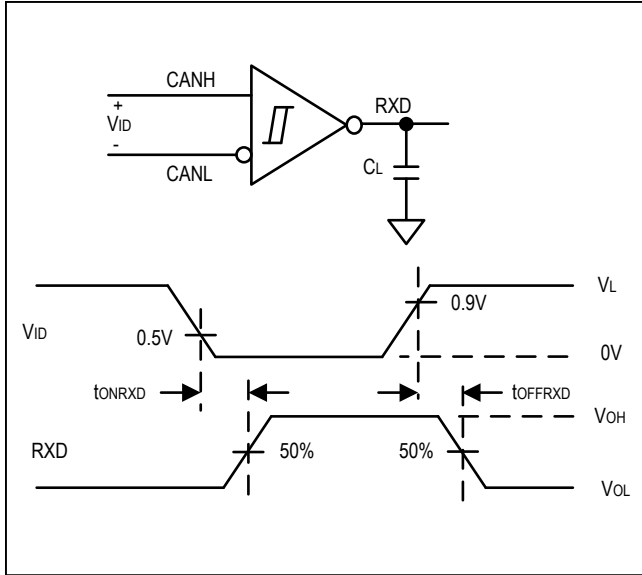

Figure 3. RXD Timing Diagram

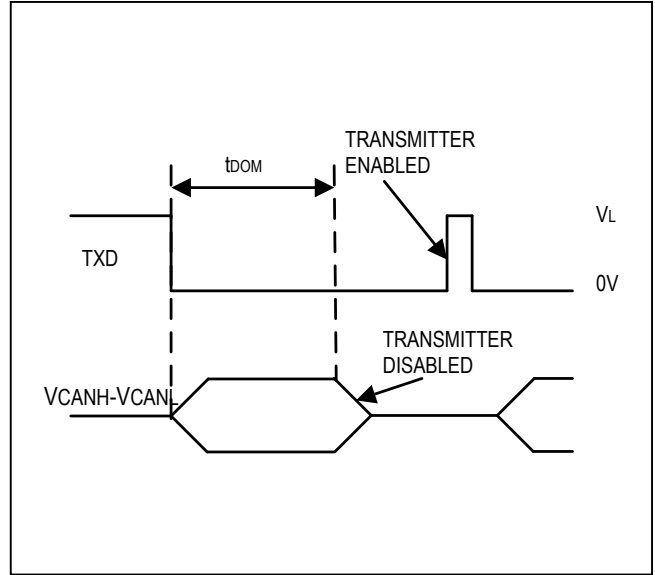

Figure 4. Transmitter-Dominant Timeout Timing Diagram

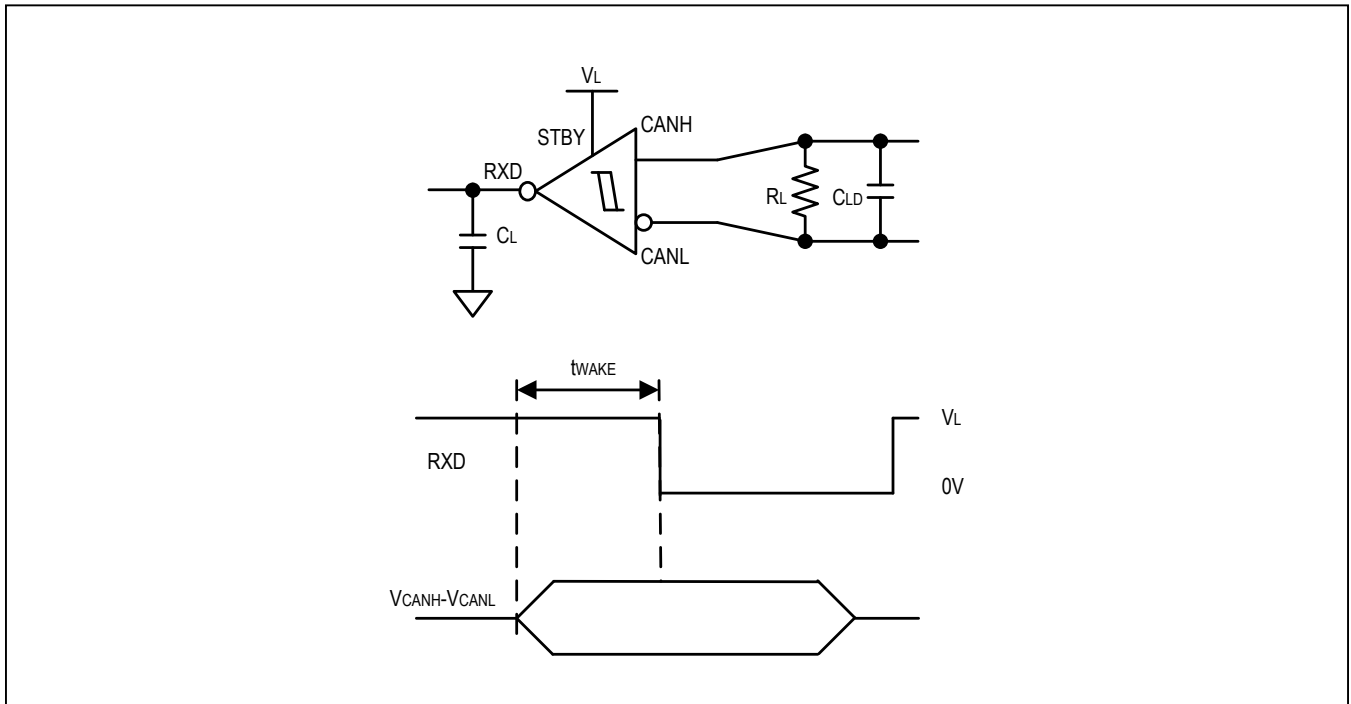
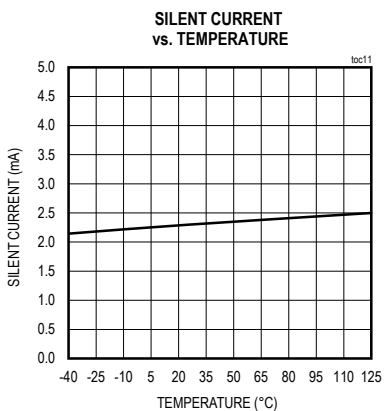
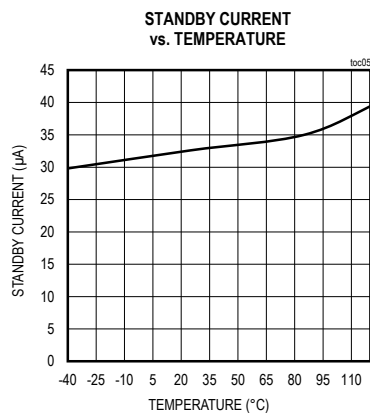
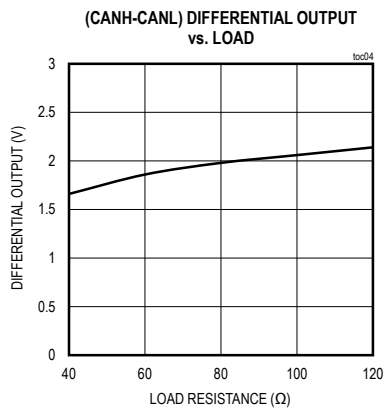
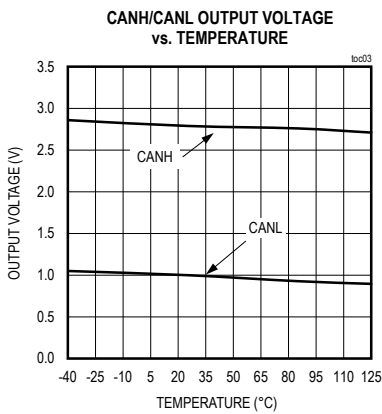
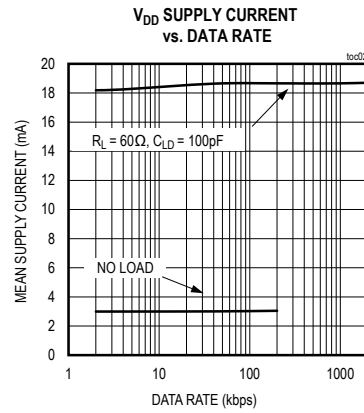
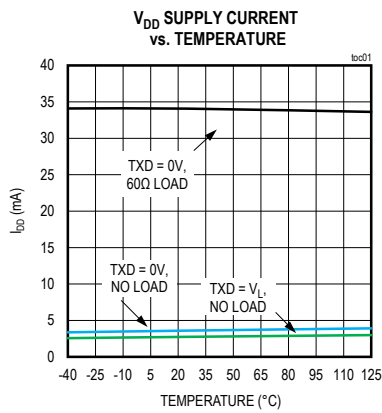

Figure 5. Standby Receiver Propagation Delay

Typical Operating Characteristics

V_{DD} = 3.3V, V_L = 1.8V, R_L = 60Ω, C_L = 15pF, T_A = +25°C, unless otherwise noted.



Typical Operating Characteristics (continued)

$V_{DD} = 3.3V$, $V_L = 1.8V$, $R_L = 60\Omega$, $C_L = 15pF$, $T_A = +25^\circ C$, unless otherwise noted.

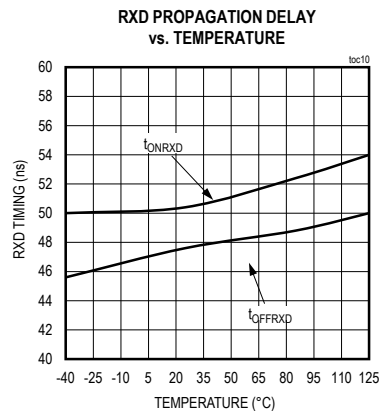
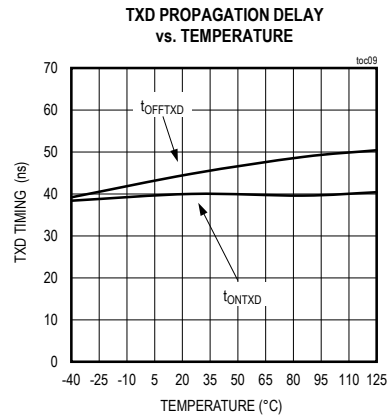
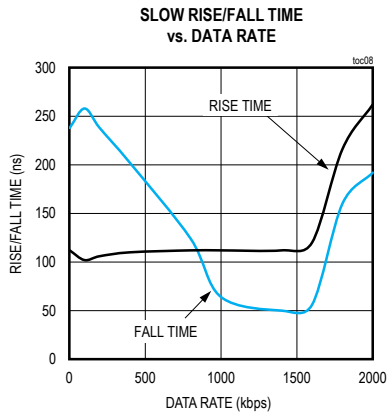
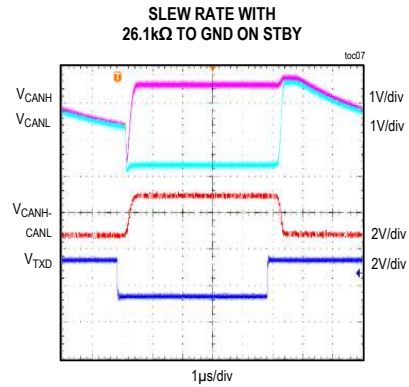
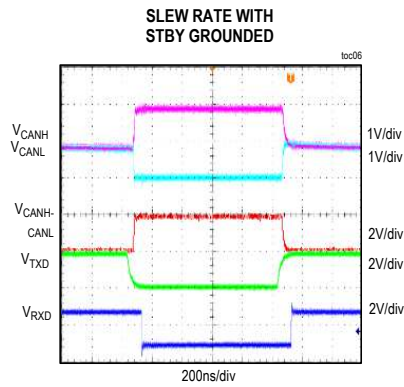

MAX33053E/MAX33054E

+3.3V, 2Mbps CAN Transceiver with ±65V Fault Protection, ±25V CMR, and ±25kV ESD

Pin Configuration

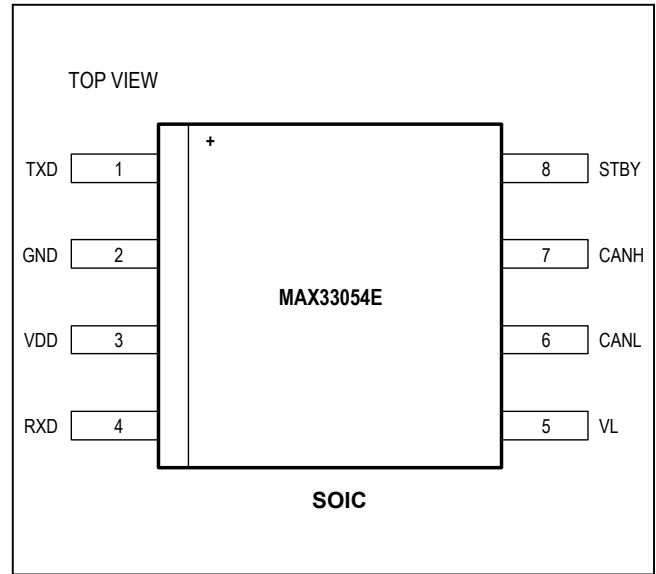
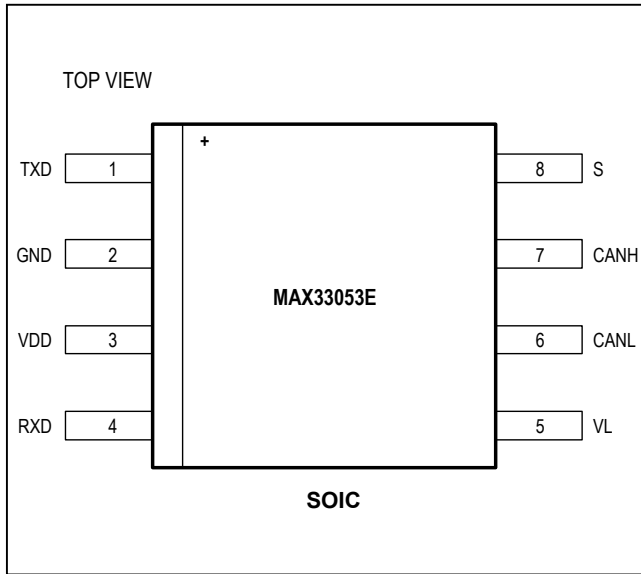

Pin Description

PIN		NAME	FUNCTION
MAX33053E	MAX33054E		
1	1	TXD	Transmit Data Input. Drive TXD high to set the driver in the recessive state. Drive TXD low to set the driver in the dominant state. TXD has an internal pullup to V_L .
2	2	GND	Ground
3	3	VDD	Supply Voltage. Bypass V_{DD} to GND with a 0.1µF capacitor.
4	4	RXD	Receive Data Output. RXD is high when CANH and CANL are in the recessive state. RXD is low when CANH and CANL are in the dominant state. RXD is referenced to V_L .
5	5	VL	Logic-Level Voltage Supply Input. Bypass V_L to GND with a 0.1µF capacitor as close to the device as possible.
6	6	CANL	CAN Bus-Line Low
7	7	CANH	CAN Bus-Line High
—	8	STBY	Standby Mode. A logic-high on STBY pin selects the standby mode. In standby mode, the transceiver is not able to transmit data and the receiver is in low-power mode. A logic-low on STBY pin puts the transceiver in normal operating mode. A 26.1kΩ external resistor can be used to connect the STBY pin to ground for the slow slew rate.
8	—	S	Silent Mode Input. Drive S low to enable TXD and to operate in high-speed mode. Drive S high to disable the transmitter. The receiver is active in normal operating mode.

Detailed Description

The MAX33053E and MAX33054E are a family of fault-protected CAN transceivers designed for harsh industrial applications with a number of integrated robust protection feature set. These devices provide a link between the CAN protocol controller and the physical wires of the bus lines in a control area network (CAN). They can be used for DeviceNet™ applications as well.

The two CAN transceivers are fault-protected up to $\pm 65V$, making it suitable for applications where overvoltage protection is required. These devices are rated up to a high $\pm 25kV$ ESD of HBM (Human Body Model), suitable for protection during the manufacturing process, and even in the field where there is human interface for installation and maintenance. In addition, a common mode voltage of $\pm 25V$ enables communication in noisy environments where there are ground plane differences between different systems due to close proximity of heavy equipment machinery or operation from different transformers. The devices' dominant timeout prevents the bus from being blocked by a hung-up microcontroller, and the outputs CANH and CANL are short-circuit, current-limited, and are protected against excessive power dissipation by thermal shutdown circuitry that places the driver outputs in a high-impedance state.

Both devices can operate up to 2Mbps, while the MAX33054E has an option to slow the slew rate to 8V/s to minimize EMI, enabling the use of unshielded twisted or parallel cable. The MAX33054E features a standby mode where it shuts off the transmitter and reduces the current to 45 μA , typical. These CAN transceivers have a V_L pin where an integrated logic level translator enable it to interface with low-voltage microcontrollers down to 1.8V $\pm 10\%$.

$\pm 65V$ Fault Protection

These devices feature $\pm 65V$ of fault protection. CANH and CANL data lines are capable of withstanding a short from -65V to +65V. This extended overvoltage range makes it suitable for applications where accidental shorts to power supply lines are possible due to human intervention.

Transmitter

The transmitter converts a single-ended input signal (TXD) from the local CAN controller to differential outputs for the bus lines CANH and CANL. The truth table for the transmitter and receiver is provided in [Table 1](#).

DeviceNet is a trademark of Open DeviceNet Vendor Association.

Transmitter Output Protection

The MAX33053E and MAX33054E protect the transmitter output stage against a short-circuit to a positive or negative voltage by limiting the driver current. Thermal shutdown further protects the devices from excessive temperatures that may result from a short or high ambient temperature. The transmitter returns to normal operation once the temperature is lowered below the threshold.

Transmitter-Dominant Timeout

The devices feature a transmitter dominant timeout (t_{DOM}) that prevents erroneous CAN controllers from clamping the bus to a dominant level by maintaining a continuous low TXD signal. When TXD remains in the dominant state (low) for greater than 2.5ms typical t_{DOM} , the transmitter is disabled, releasing the bus to a recessive state ([Figure 4](#)). After a dominant timeout fault, the transmitter is re-enabled when receiving a rising edge at TXD. The transmitter dominant timeout limits the minimum possible data rate to 9kbps for standard CAN protocol.

Receiver

The receiver reads the differential input from the bus line CANH and CANL and transfers this data as a single-ended output RXD to the CAN controller. It consists of a comparator that senses the difference $V_{DIFF} = (CANH - CANL)$, with respect to an internal threshold of 0.7V. If $V_{DIFF} > 0.9V$, a logic-low is present on RXD. If $V_{DIFF} < 0.5V$, a logic-high is present. The CANH and CANL common-mode range is $\pm 25V$. RXD is a logic-high when CANH and CANL are shorted or terminated and undriven.

Standby Mode (MAX33054E)

Drive STBY pin high for standby mode, which switches the transmitter off and the receiver to a low current and low-speed state. The supply current is reduced during standby mode. The bus line is monitored by a low differential comparator to detect and recognize a wakeup event on the bus line. Once the comparator detects a dominant bus level greater than 2.5 μs typical t_{WAKE} , RXD pulls low. Drive the STBY low for normal operation.

Slow Slew Rate (MAX33054E)

Connect a 26.1k Ω resistor between ground and the STBY pin. The STBY pin voltage should be between 0.1V to 0.6V to remain in slow slew rate. This will change the MAX33054E with a slow slew rate of 8V/ μs for rising edge compared with normal mode at 180V/ μs . For falling edge, the slow slew rate is 20V/ μs compared with normal mode at 140V/ μs .

MAX33053E/MAX33054E

+3.3V, 2Mbps CAN Transceiver with ±65V Fault Protection, ±25V CMR, and ±25kV ESD

Silent Mode (MAX33053E)

Drive S high to place the MAX33053E in silent mode. This disables the transmitter regardless of the voltage level at TXD. However, RXD is still active and monitors activity on the bus line.

Logic Compatibility

A separate input V_L allows the MAX33053E and MAX33054E to communicate with logic systems down to 1.62V while operating up to a +3.6V supply. This provides a reduced input voltage threshold to the TXD, STBY, and S inputs, and provides a logic-high output at RXD compatible with the microcontroller's supply rail. The logic compatibility eliminates an external logic level translator and longer propagation delay due to level shifting. Connect V_L to V_{DD} to operate with +3.3V logic systems.

Applications Information

Reduced EMI and Reflections

In multidrop CAN applications, it is important to maintain a single linear bus of uniform impedance that is properly terminated at each end. A star, ring, or tree configuration should never be used. Any deviation from the end-to-end wiring scheme creates a stub. High-speed data edges on a stub can create reflections back down to the bus. These reflections can cause data errors by eroding the noise margin of the system.

Although stubs are unavoidable in a multidrop system, care should be taken to keep these stubs as short as possible, especially when operating with high data rates.

Table 1. Transmitter and Receiver Truth Table (When Not Connected to the Bus)

STBY	TXD	TXD LOW TIME	CANH	CANL	BUS STATE	RXD
LOW	LOW	$< t_{DOM}$	HIGH	LOW	DOMINANT	LOW
LOW	LOW	$> t_{DOM}$	$V_{DD}/2$	$V_{DD}/2$	RECESSIVE	HIGH
LOW	HIGH	X	$V_{DD}/2$	$V_{DD}/2$	RECESSIVE	HIGH

X = Don't care

Typical Application Circuits

Multidrop CAN Bus

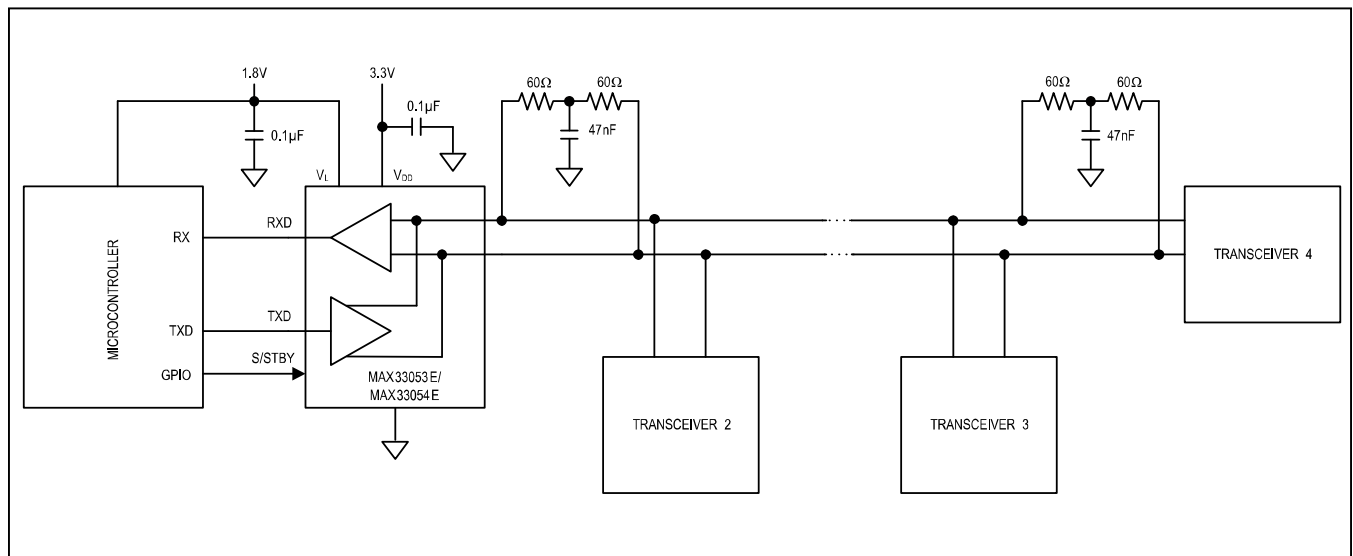

MAX33053E/MAX33054E

+3.3V, 2Mbps CAN Transceiver with $\pm 65V$
Fault Protection, $\pm 25V$ CMR, and $\pm 25kV$ ESD

Ordering Information

PART NUMBER	PIN 8	TEMP RANGE	PIN-PACKAGE
MAX33053EASA+	S (Silent)	-40°C to +125°C	8 SO
MAX33054EASA+	STBY (Standby)	-40°C to +125°C	8 SO

+Denotes a lead(Pb)-free/RoHS-compliant package.

MAX33053E/MAX33054E

+3.3V, 2Mbps CAN Transceiver with $\pm 65V$
Fault Protection, $\pm 25V$ CMR, and $\pm 25kV$ ESD

Revision History

REVISION NUMBER	REVISION DATE	DESCRIPTION	PAGES CHANGED
0	5/18	Initial release	—
1	4/20	Added the POD	4

For pricing, delivery, and ordering information, please contact Maxim Direct at 1-888-629-4642, or visit Maxim Integrated's website at www.maximintegrated.com.

Maxim Integrated cannot assume responsibility for use of any circuitry other than circuitry entirely embodied in a Maxim Integrated product. No circuit patent licenses are implied. Maxim Integrated reserves the right to change the circuitry and specifications without notice at any time. The parametric values (min and max limits) shown in the Electrical Characteristics table are guaranteed. Other parametric values quoted in this data sheet are provided for guidance.