

# BASE CAGE DETAILS

1000143242

SHOWN

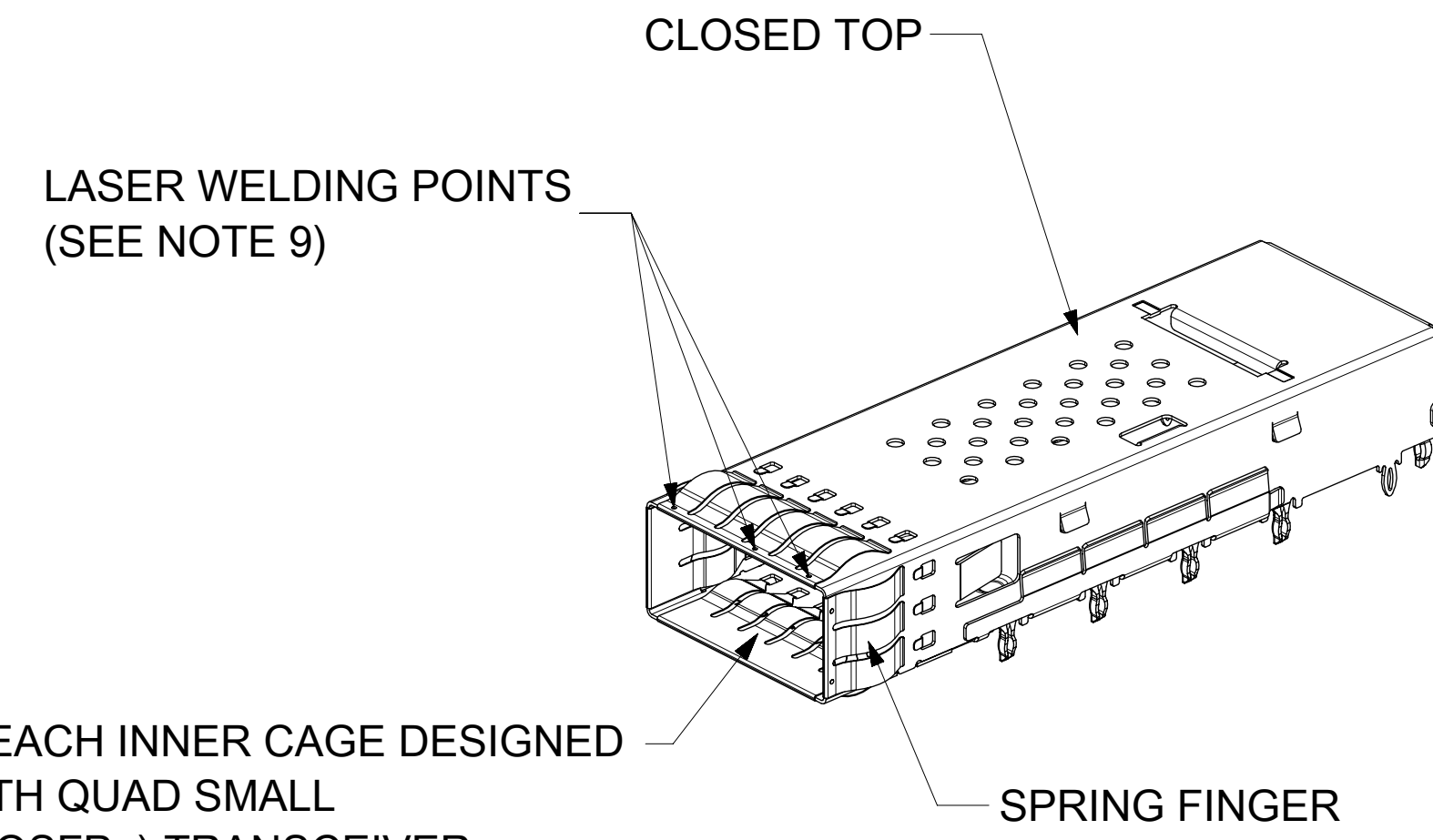
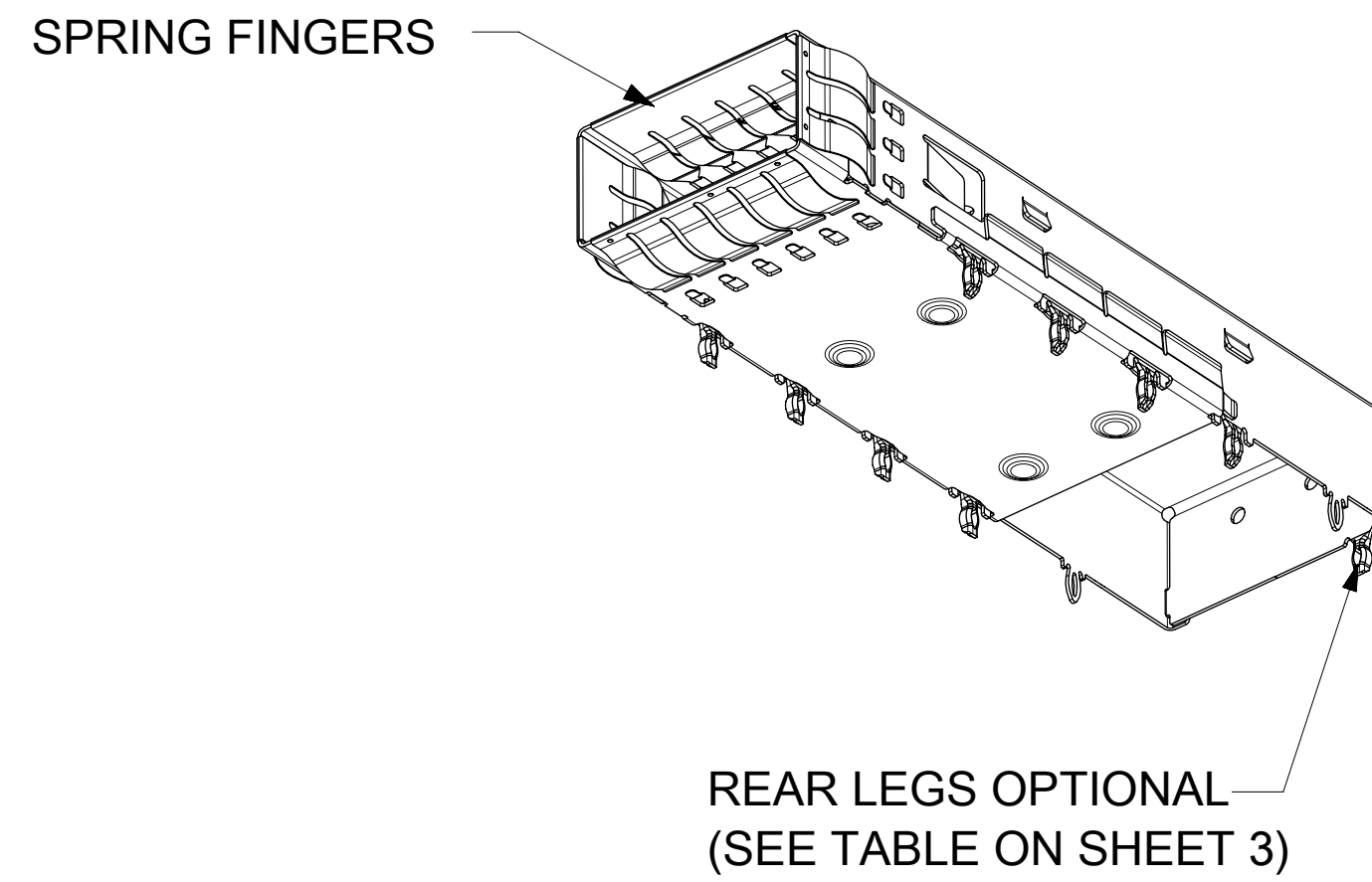
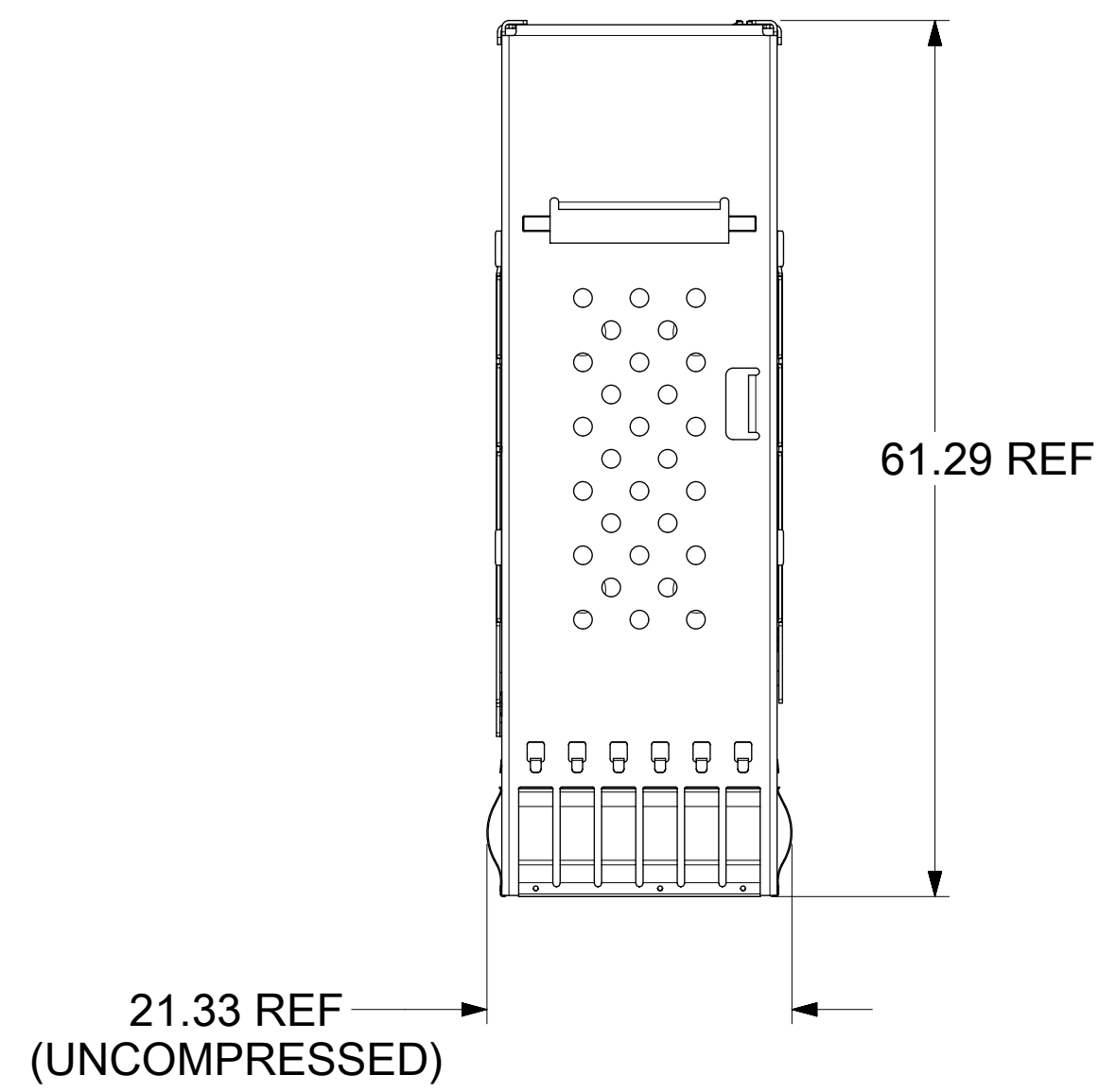

DIMENSIONS OF EACH INNER CAGE DESIGNED TO FUNCTION WITH QUAD SMALL FORM-FACTOR (zQSFP+) TRANSCEIVER

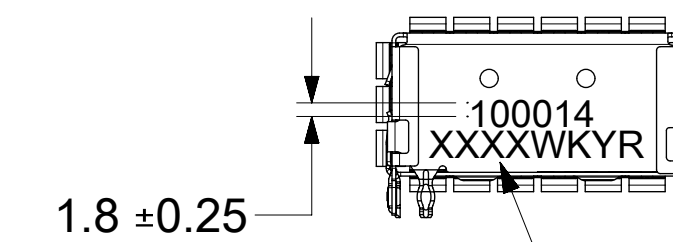
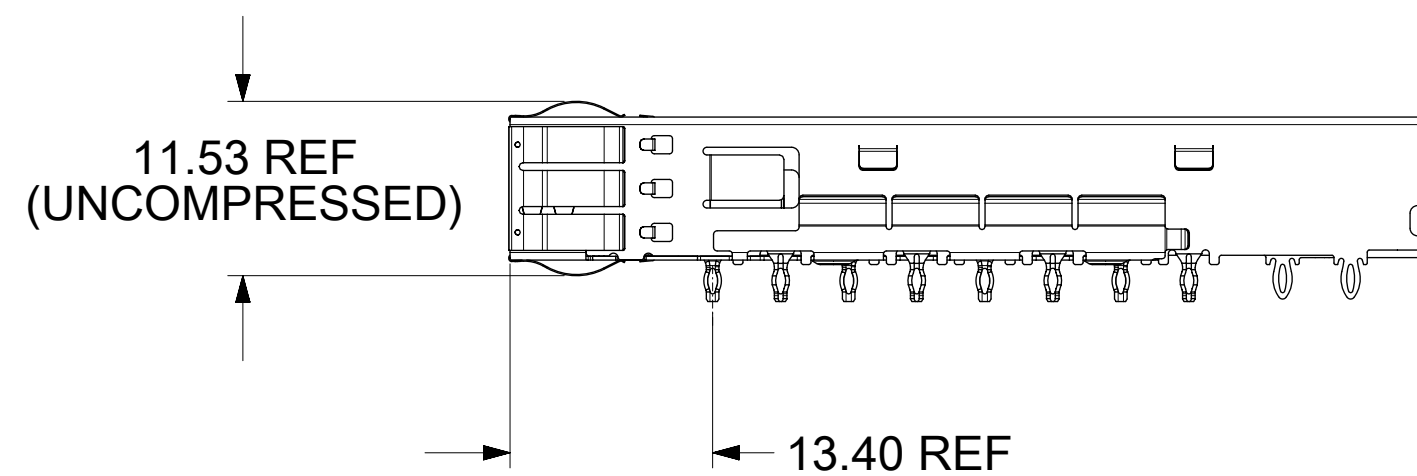
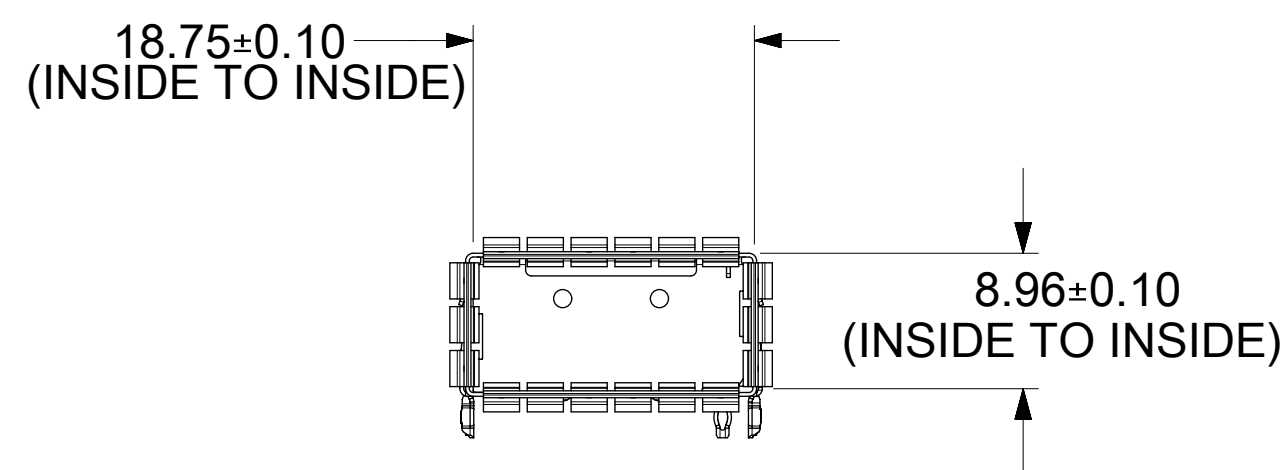

1.8 ±0.25

P/N AND WEEK/YEAR DATE CODE TO BE PRINTED ON BACK OF COMPLETED CAGE ASSEMBLY APPROXIMATELY AS SHOWN. SEE TABLE BELOW FOR DATE CODE INFORMATION.

- NOTES:
- MATERIAL: CAGE: STAINLESS STEEL  
SPRING FINGERS: STAINLESS STEEL  
HEAT SINKS: NICKEL PLATED ALUMINUM  
HEAT SINK CLIP: STAINLESS STEEL  
LIGHT PIPES: POLYCARBONATE (UL 94-V-0)
  - DIMENSIONS MARKED ARE CRITICAL TO FUNCTION OF THE PART AND MUST BE INSPECTED
  - DRAWING APPLIES TO ALL P/N'S SHOWN ON PAGE 3
  - DURING FINAL INSPECTION, CAGE LEG LOCATIONS AND STRAIGHTNESS MUST BE CHECKED USING APPROPRIATE GO - NO GO GAGE
  - DURING FINAL INSPECTION, CAGE MUST BE INSPECTED TO MAKE SURE LEG CONFIGURATIONS AND PART NUMBERS ARE CORRECT, USE SHEETS 3, 4 AND 5
  - PARTS TO BE INSPECTED PER MOLEX COSMETIC SPEC WI-HP-7-2774 (CLASS B UNLESS OTHERWISE SPECIFIED)
  - PRESS-FIT LEGS 2.44 [0.096] LONG -  
1.57 [0.062] MINIMUM PCB THICKNESS FOR SINGLE SIDED USE.  
3.00 [0.118] MINIMUM PCB THICKNESS FOR BELLY TO BELLY USE.
  - NO RoHS EXEMPTIONS
  - WELD SPOTS MAY SHOW SLIGHT MATERIAL DISCOLORATION.

WEEK/YEAR DATE CODE TABLE													
WK	WEEK OF THE YEAR 01 THRU 52 (EXAMPLE: 01= FIRST WEEK OF YEAR 52= LAST WEEK OF YEAR)												
YR	22, 23, 24 ETC.. (EXAMPLE: YEAR 2022= 22)												
FUNCTIONAL SYMBOLS	THIS DRAWING CONTAINS INFORMATION THAT IS PROPRIETARY TO MOLEX ELECTRONIC TECHNOLOGIES, LLC AND SHOULD NOT BE USED WITHOUT WRITTEN PERMISSION												
	FA = 0	mm	SCALE	2:1	CURRENT REV DESC: SEE REVISION TABLE					<p>ZQSFP+ 1X1 CAGE ASSY'S W/ SUS TAB TYPE SPRING FINGER, H/S &amp; L/P OPTIONS</p> <p>PRODUCT CUSTOMER DRAWING</p>			
	FC = 0	GENERAL TOLERANCES (UNLESS SPECIFIED)			EC NO: 698842								
	FP = 1	ANGULAR TOL ± 2.0°			DRWN: TKUMARKC 2022/02/17								
DIVISIONAL SYMBOLS	4 PLACES	±				CHK'D: TKUMARKC 2022/03/16							
	3 PLACES	±				APPR: JCHIANG 2022/03/28							
	2 PLACES	±	0.15				INITIAL REVISION:						
	1 PLACE	±	0.25				DRWN: TKUMARKC 2022/02/17						
	0 PLACES	±					APPR: JCHIANG 2022/03/28						
DRAFT WHERE APPLICABLE MUST REMAIN WITHIN DIMENSIONS		THIRD ANGLE PROJECTION		DRAWING		SERIES		MATERIAL NUMBER		CUSTOMER		SHEET NUMBER	
				D-SIZE		100014		1000143200		GENERAL MARKET		1 OF 7	

# CAGE ASSEMBLY OPTIONS

1000143541

SHOWN

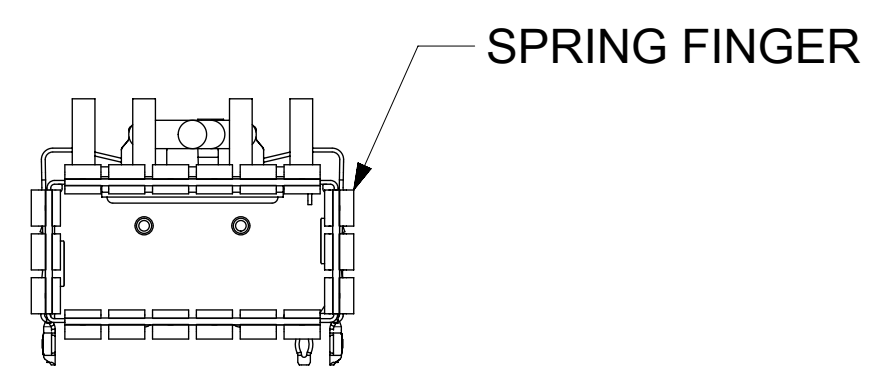
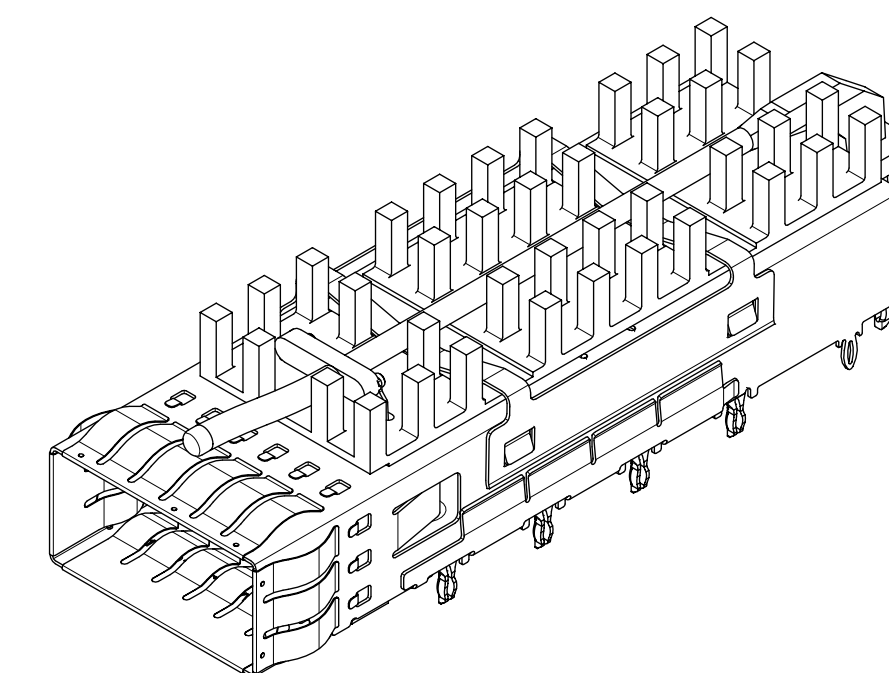
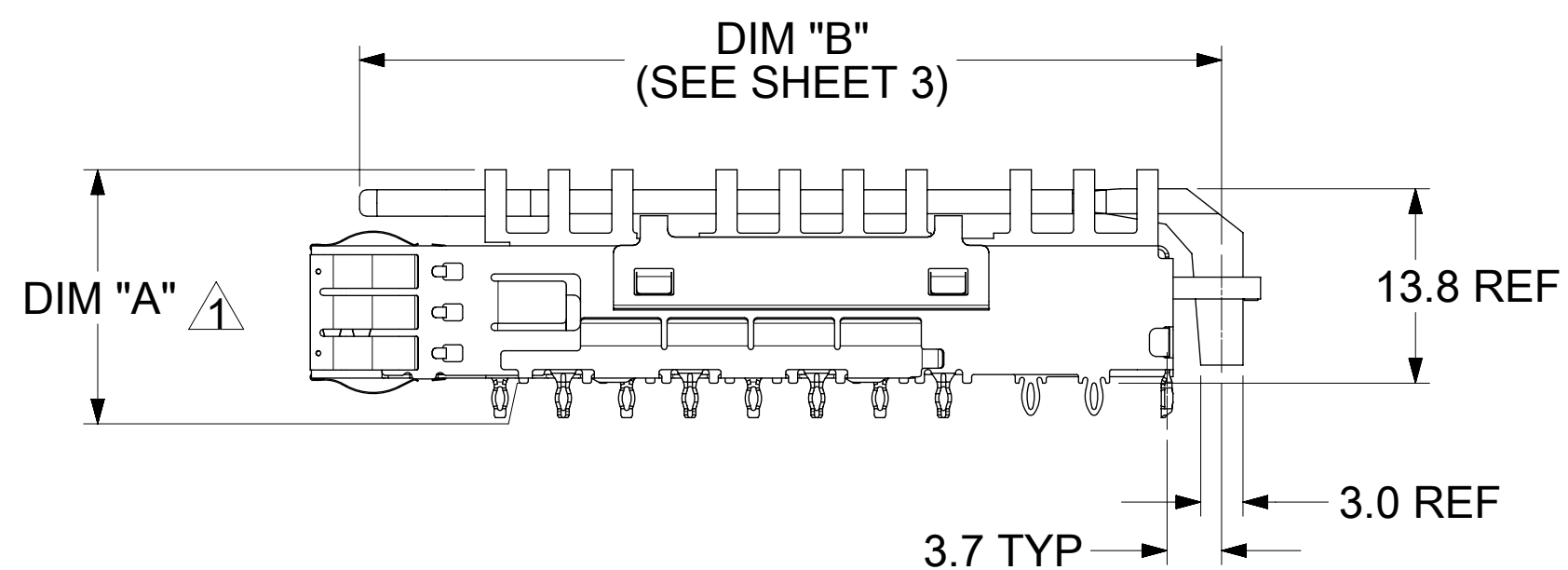
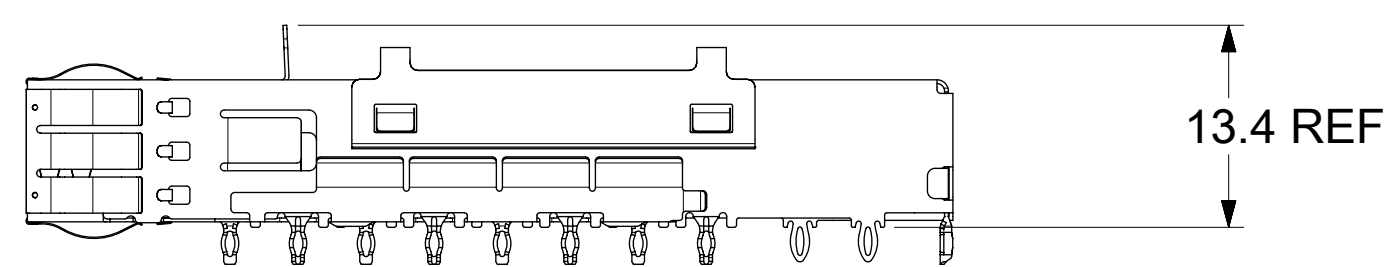
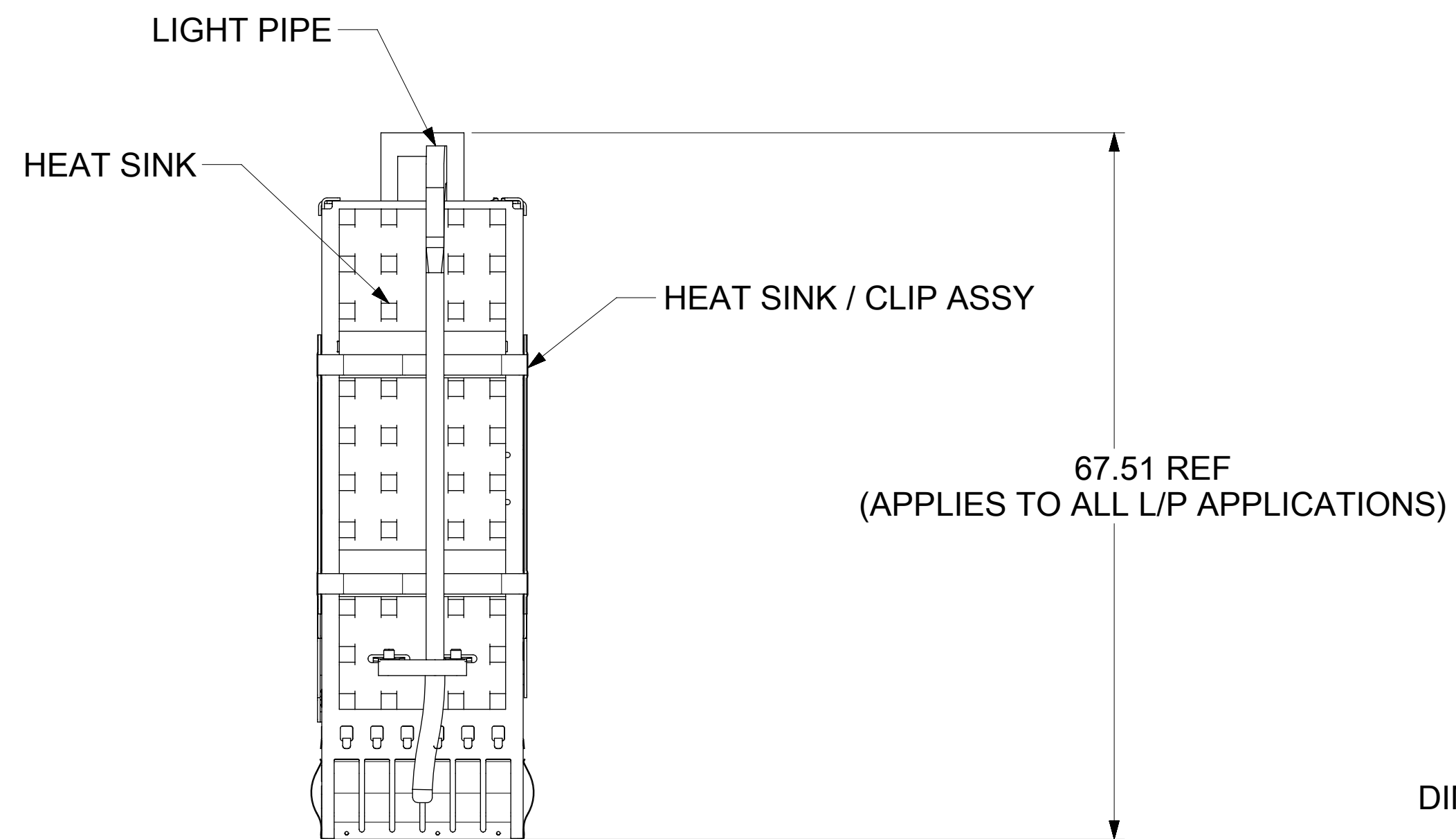

## HEATSINK HEIGHT OPTIONS

OVERALL HEAT SINK HEIGHT	DIM "A"
PCI	13.7 REF
SAN	16.0 REF
NET	23.0 REF

HEIGHT OF HEAT SINK WITH MODULE INSERTED. DIMENSION MAY BE LESS DUE TO MODULE AND HEAT SINK VARIATIONS

## REAR LEG OPTIONS

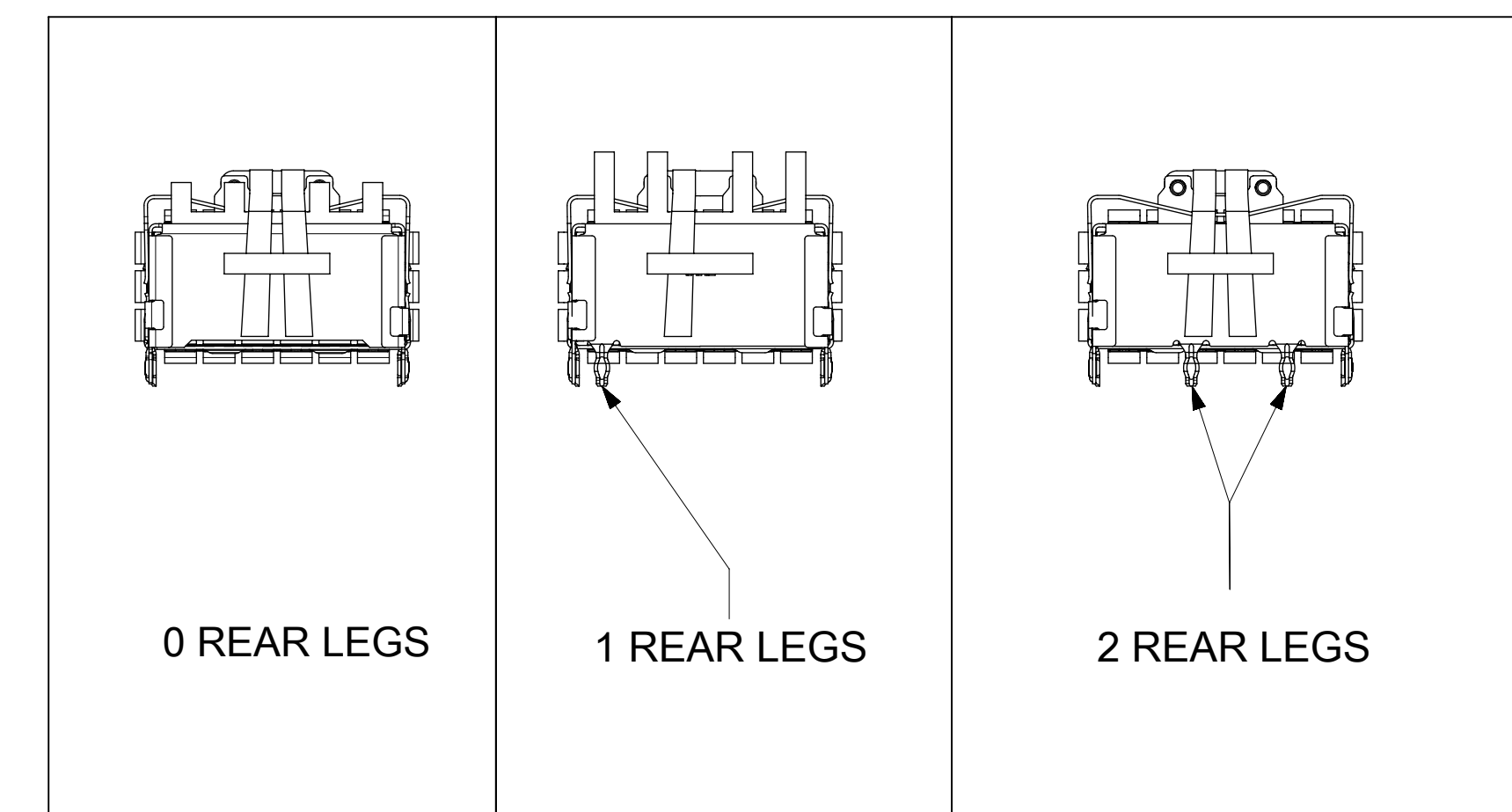

HEAT SINK USED WITHOUT LIGHTPIPE

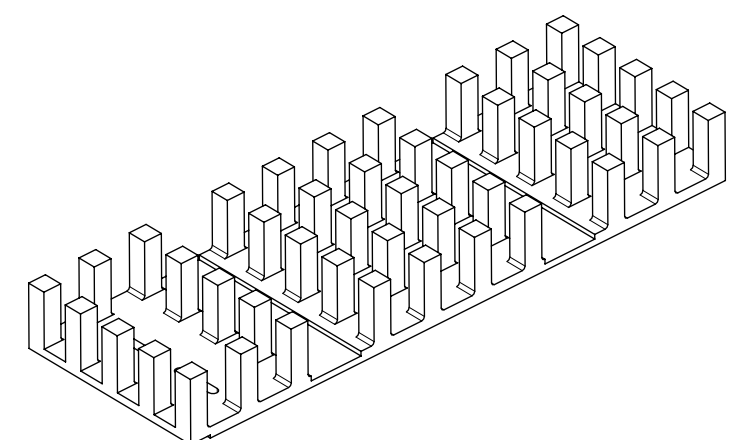

SINGLE / DUAL LIGHT PIPE

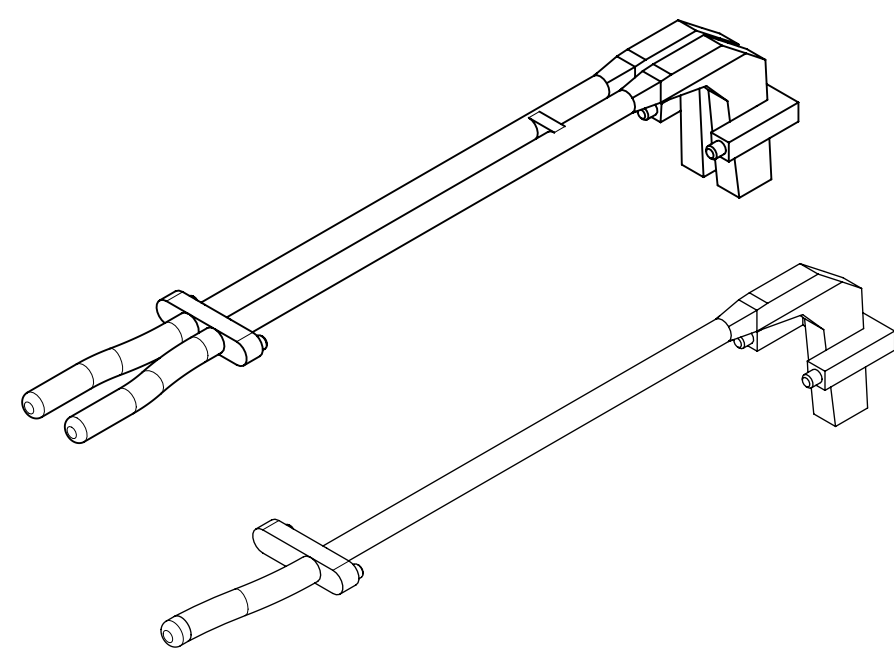

HEATSINK

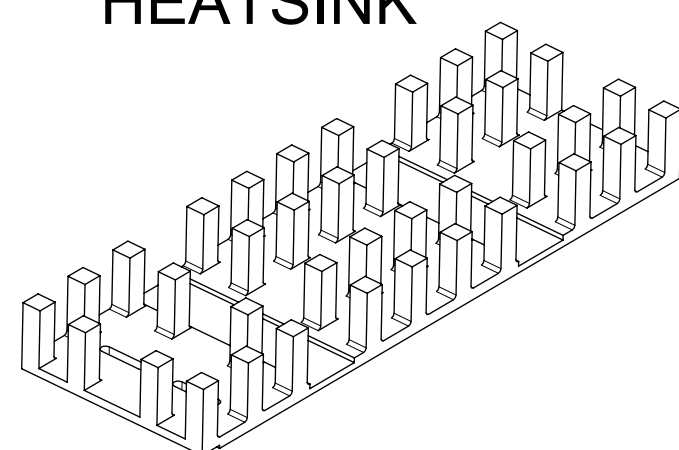

QUAD LIGHT PIPE

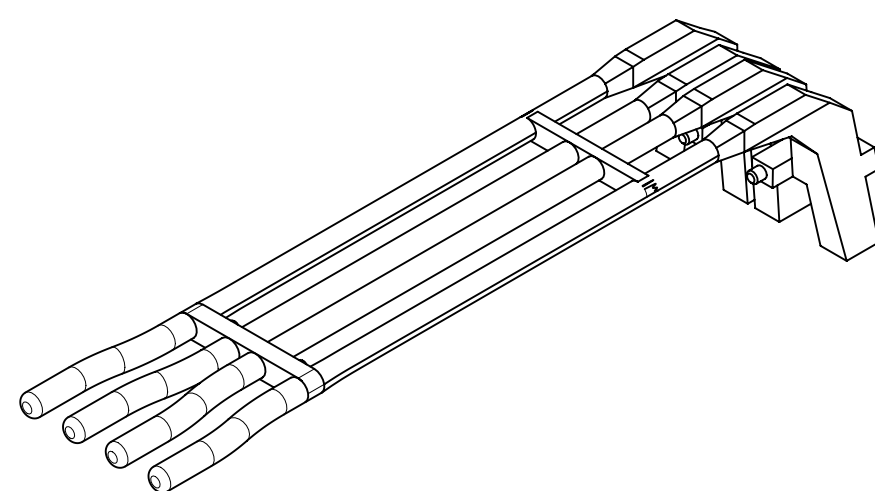

HEATSINK

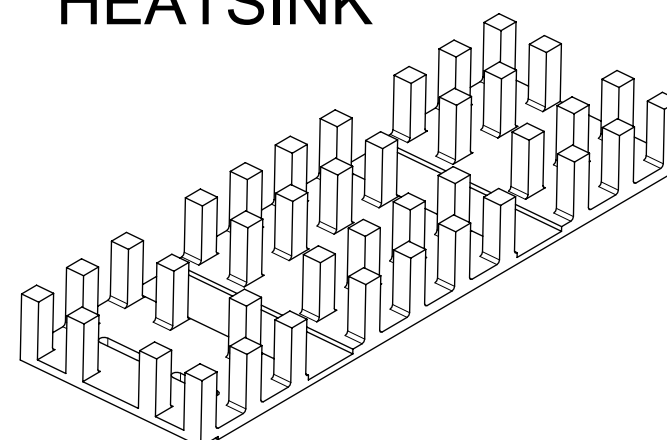

FUNCTIONAL SYMBOLS $F_A = 0$ $F_C = 0$ $F_D = 0$	THIS DRAWING CONTAINS INFORMATION THAT IS PROPRIETARY TO MOLEX ELECTRONIC TECHNOLOGIES, LLC AND SHOULD NOT BE USED WITHOUT WRITTEN PERMISSION		CURRENT REV DESC: SEE REVISION TABLE	
	DIMENSION UNITS	SCALE		
	mm	2:1		
	GENERAL TOLERANCES (UNLESS SPECIFIED)			
ANGULAR TOL $\pm 2.0^\circ$				
4 PLACES $\pm$		EC NO: 698842		
3 PLACES $\pm$		DRWN: TKUMARKC 2022/02/17		
2 PLACES $\pm 0.15$		CHK'D: TKUMARKC 2022/03/16		
1 PLACE $\pm 0.25$		APPR: JCHIANG 2022/03/28		
0 PLACES $\pm$		INITIAL REVISION:		
DRAFT WHERE APPLICABLE MUST REMAIN WITHIN DIMENSIONS		DRWN: TKUMARKC 2022/02/17		
THIRD ANGLE PROJECTION		APPR: JCHIANG 2022/03/28		
DRAWING		SERIES		
D-SIZE		100014		
MATERIAL NUMBER		CUSTOMER		
1000143200		GENERAL MARKET		
DOC TYPE		DOC PART		
PSD		ASY		
REVISION		A		
DOCUMENT NUMBER		SHEET NUMBER		
1000143200		2 OF 7		

# PART NUMBER SELECTION

NO HEATSINKS  
WITH LIGHT PIPES  
CLOSED TOP

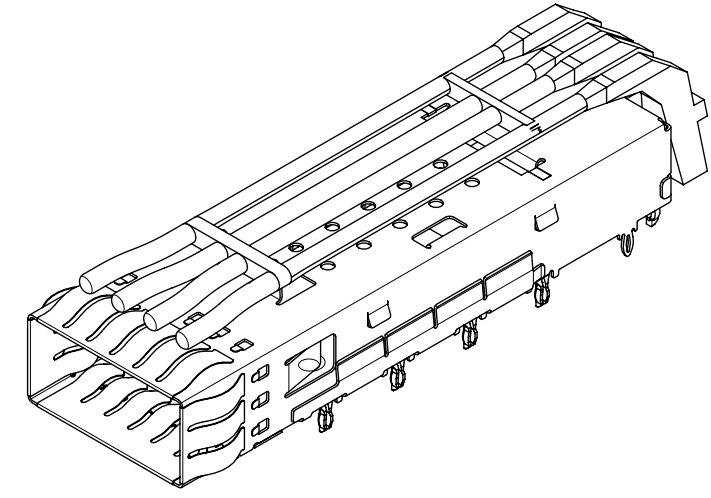

MOLEX P/N	LIGHT PIPES	#OF REAR LEGS PER PORT	DIM "B"
1000143235	QUAD	0	61.07 REF

NO HEATSINKS  
NO LIGHT PIPES  
CLOSED TOP

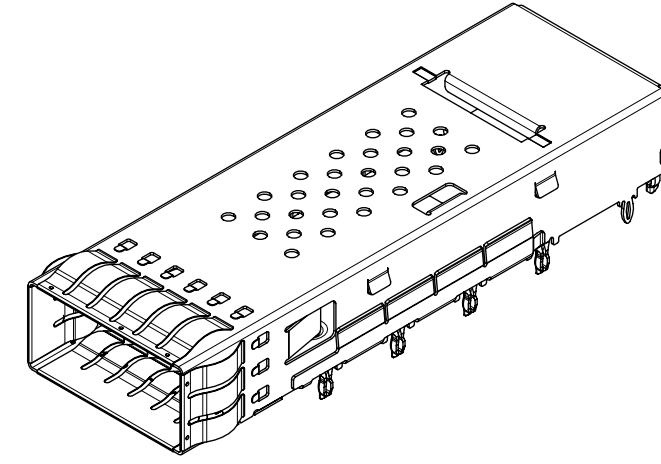

MOLEX P/N W/ SPRING FINGERS	#OF REAR LEGS PER PORT
1000143240	0
1000143242	1

NO HEATSINKS  
NO LIGHT PIPES  
OPEN TOP

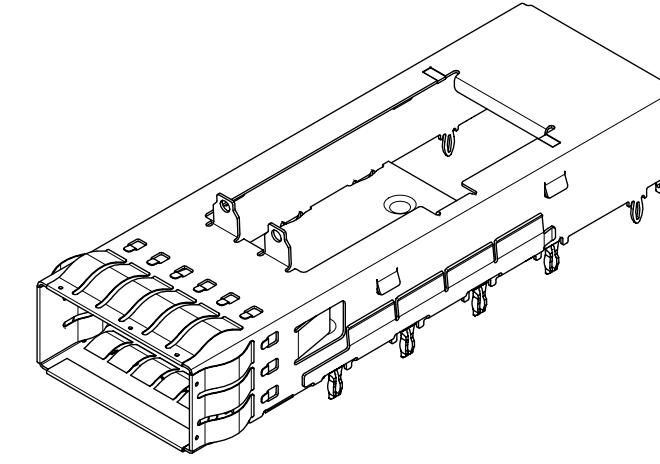

MOLEX P/N W/ SPRING FINGERS	#OF REAR LEGS PER PORT	LP TAB FEATURE
1000143250	0	YES
1000143252	1	YES

WITH HEATSINKS  
NO LIGHT PIPES

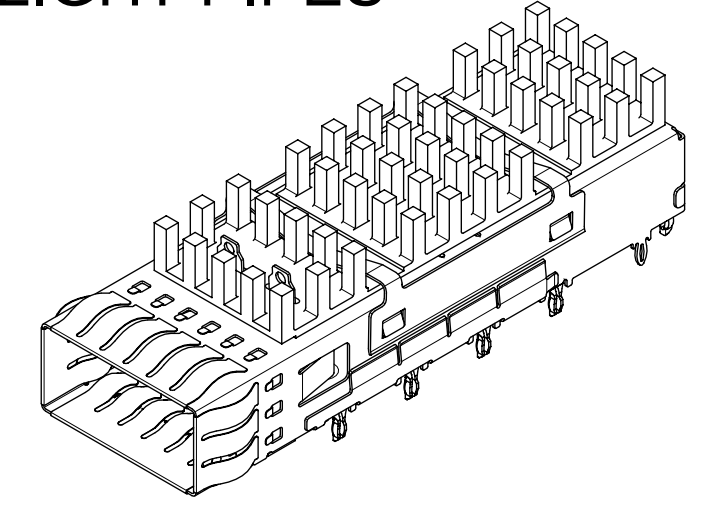

MOLEX P/N	HEATSINKS	#OF REAR LEGS PER PORT
1000143340	PCI	0
1000143341	SAN	0
1000143342	NET	0
1000143343	PCI	1
1000143344	SAN	1
1000143345	NET	1
1000143346	PCI	2

## SINGLE LIGHT PIPE

## DUAL LIGHT PIPE

## QUAD LIGHT PIPE

WITH HEATSINKS AND LIGHT PIPES

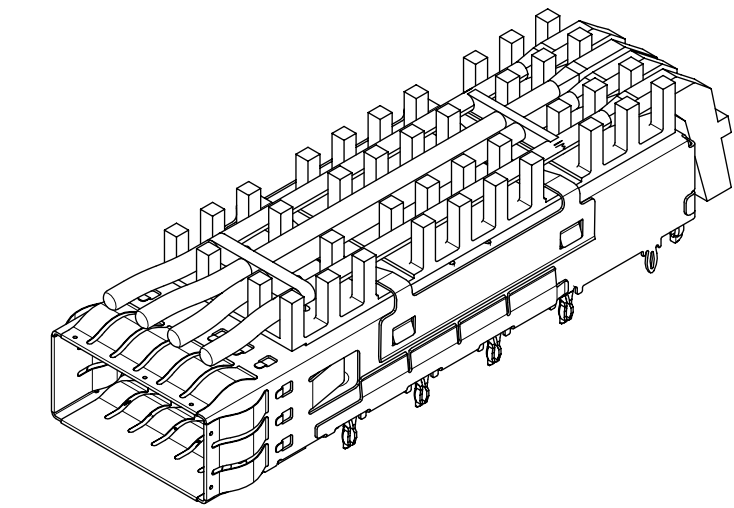
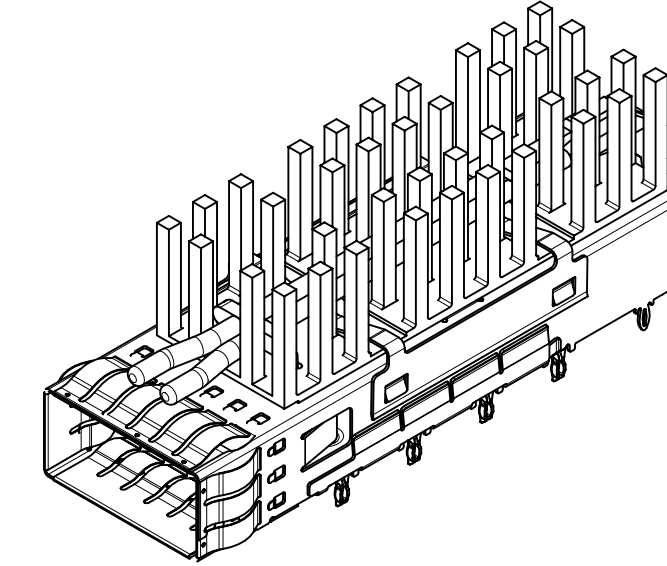
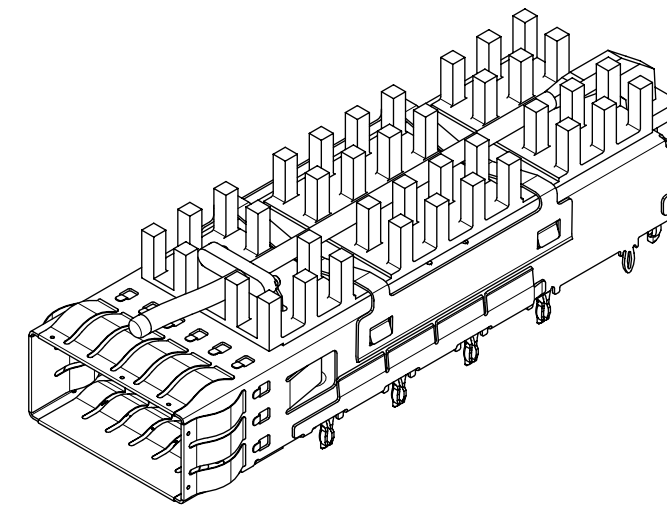

MOLEX P/N	LIGHTPIPES	HEATSINKS	#OF REAR LEGS PER PORT	DIM "B"
1000143442	SINGLE	NET	0	61.07 REF
1000143443	DUAL	PCI	0	61.07 REF
1000143445	DUAL	NET	0	61.07 REF
1000143447	QUAD	SAN	0	61.07 REF
1000149448	QUAD	NET	0	61.07 REF
1000143541	SINGLE	SAN	1	61.07 REF
1000143542	SINGLE	NET	1	61.07 REF
1000149547	QUAD	SAN	1	61.07 REF
1000143548	QUAD	NET	1	61.07 REF
1000143646	QUAD	PCI	2	61.07 REF

<b>FUNCTIONAL SYMBOLS</b> FA = 0 EC = 0 EP = 0 <b>DIVISIONAL SYMBOLS</b>	THIS DRAWING CONTAINS INFORMATION THAT IS PROPRIETARY TO MOLEX ELECTRONIC TECHNOLOGIES, LLC AND SHOULD NOT BE USED WITHOUT WRITTEN PERMISSION		CURRENT REV DESC: SEE REVISION TABLE	
	DIMENSION UNITS	SCALE		
	mm	1.5:1		
	GENERAL TOLERANCES (UNLESS SPECIFIED)			
ANGULAR TOL ± 2.0°				
4 PLACES ±		EC NO: 698842		
3 PLACES ±		DRWN: TKUMARKC 2022/02/17		
2 PLACES ± 0.15		CHK'D: TKUMARKC 2022/03/16		
1 PLACE ± 0.25		APPR: JCHIANG 2022/03/28		
0 PLACES ±		INITIAL REVISION:		
DRAFT WHERE APPLICABLE MUST REMAIN WITHIN DIMENSIONS		DRWN: TKUMARKC 2022/02/17		
THIRD ANGLE PROJECTION		APPR: JCHIANG 2022/03/28		
D-DRAWING		SERIES		
D-SIZE		100014		
MATERIAL NUMBER		CUSTOMER		
1000143200		GENERAL MARKET		
DOCUMENT NUMBER		DOC TYPE DOC PART REVISION		
1000143200		PSD ASY A		
SHEET NUMBER		3 OF 7		

# PCB LAYOUT FOR SINGLE SIDED MOUNTING

NO REAR LEGS

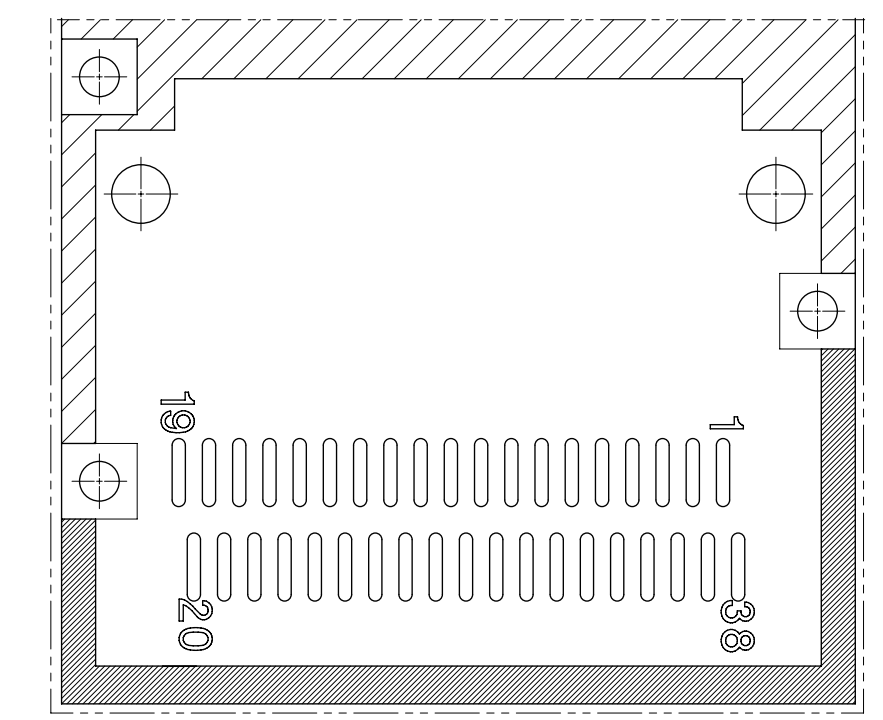

PARTIAL 1  
SCALE 5:1

1 REAR LEG

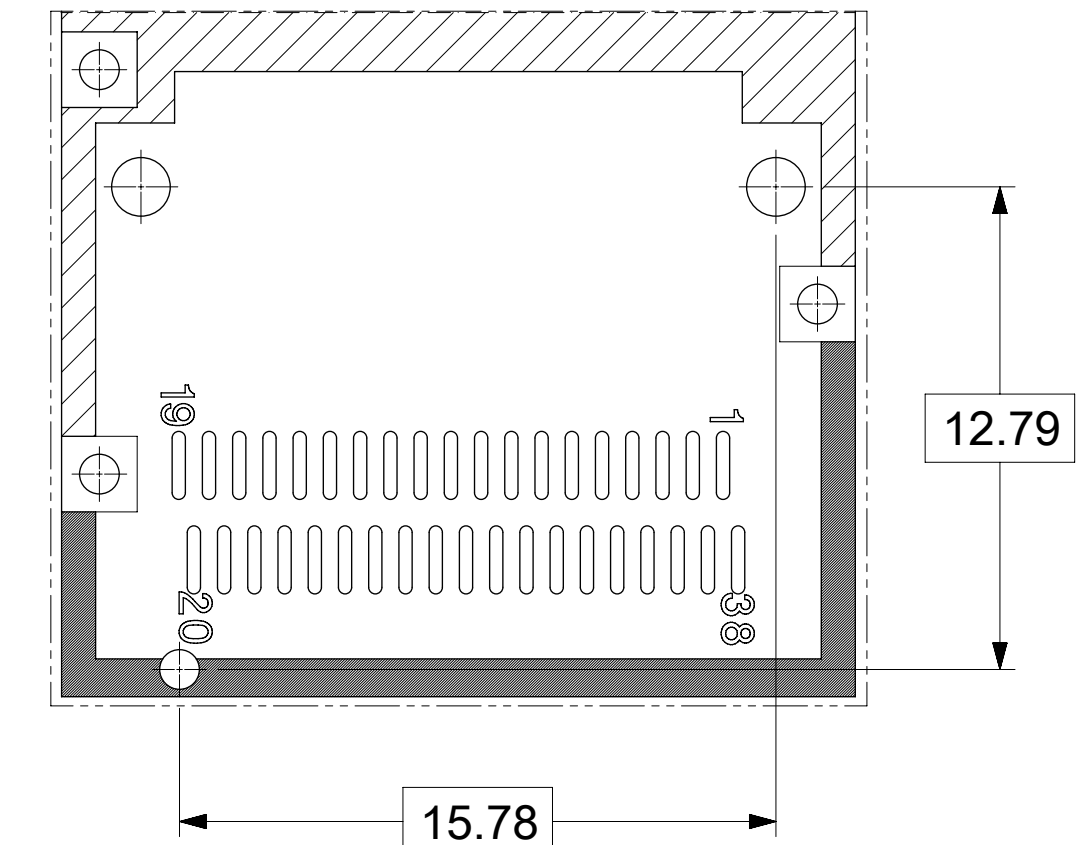

PARTIAL 2  
SCALE 5:1

2 REAR LEGS

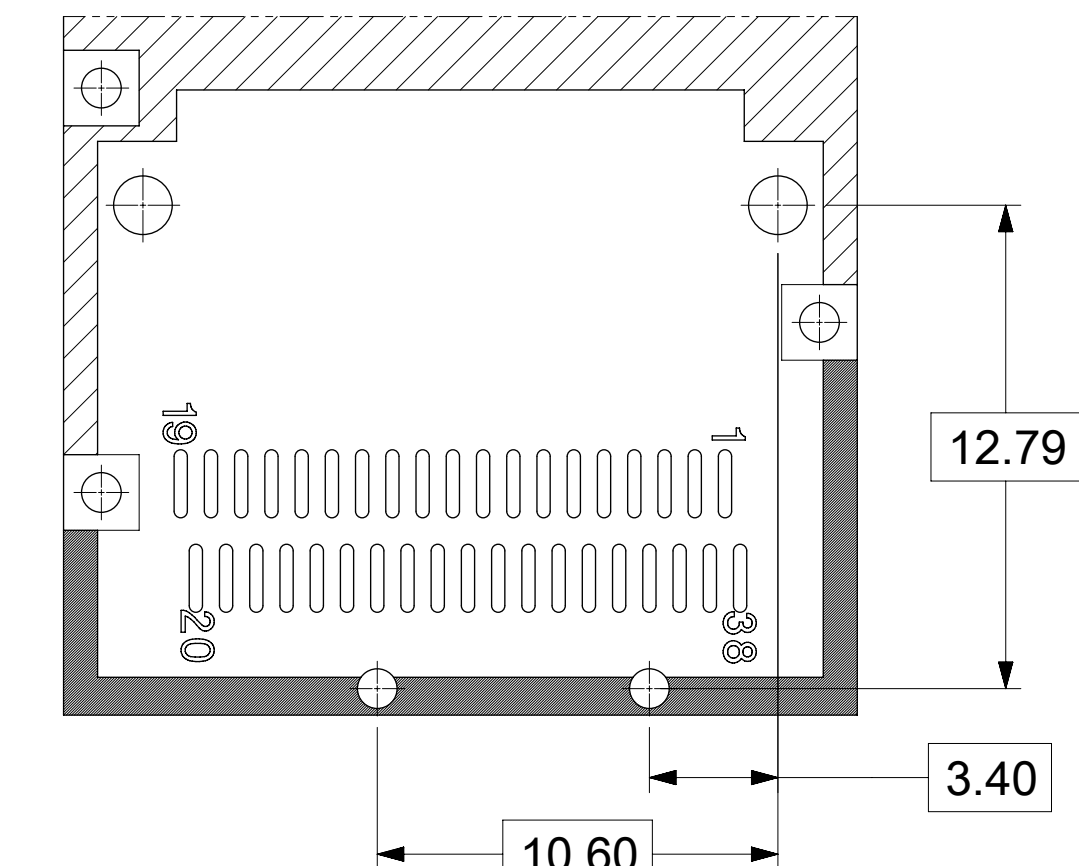

PARTIAL 3  
SCALE 5:1

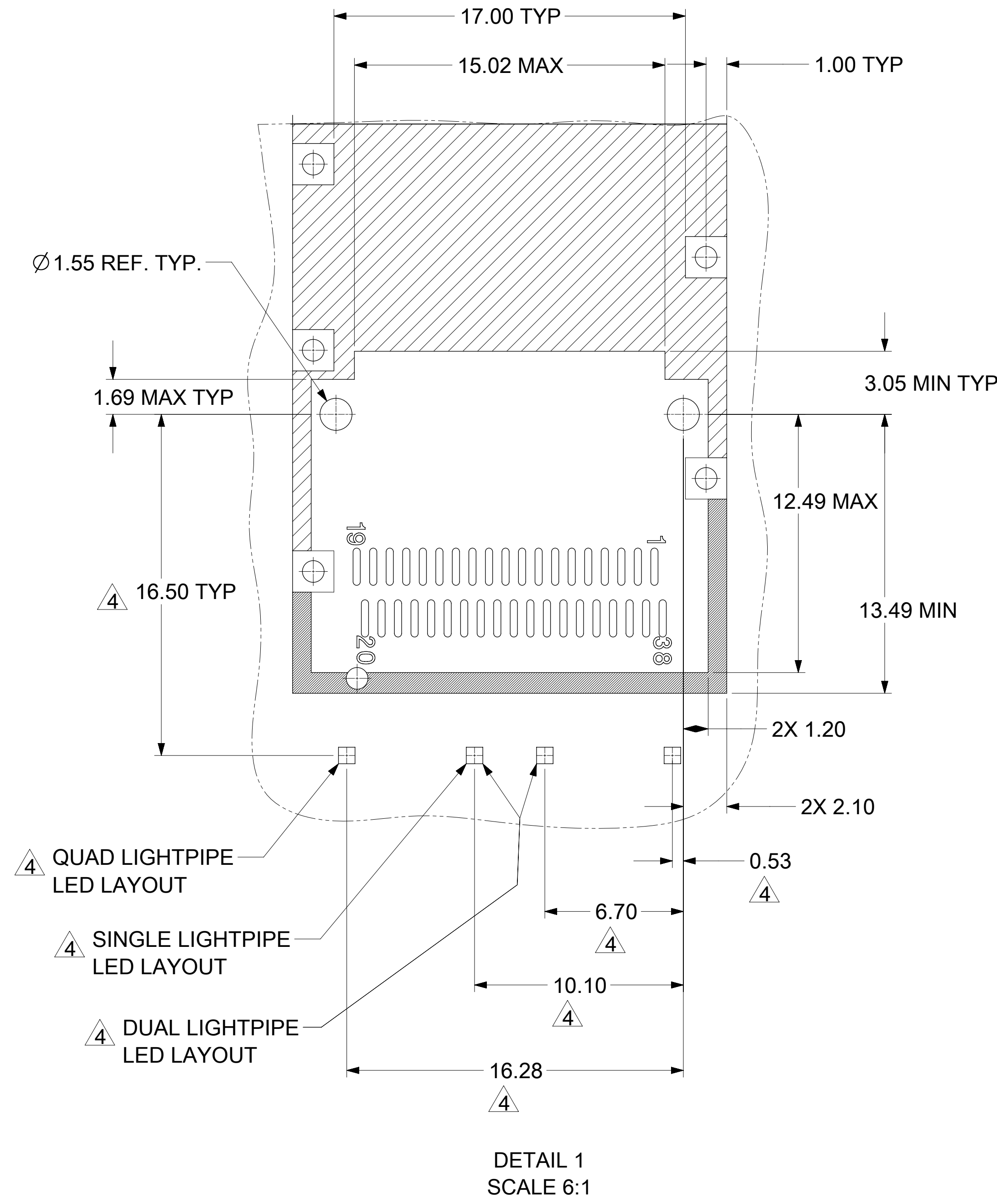
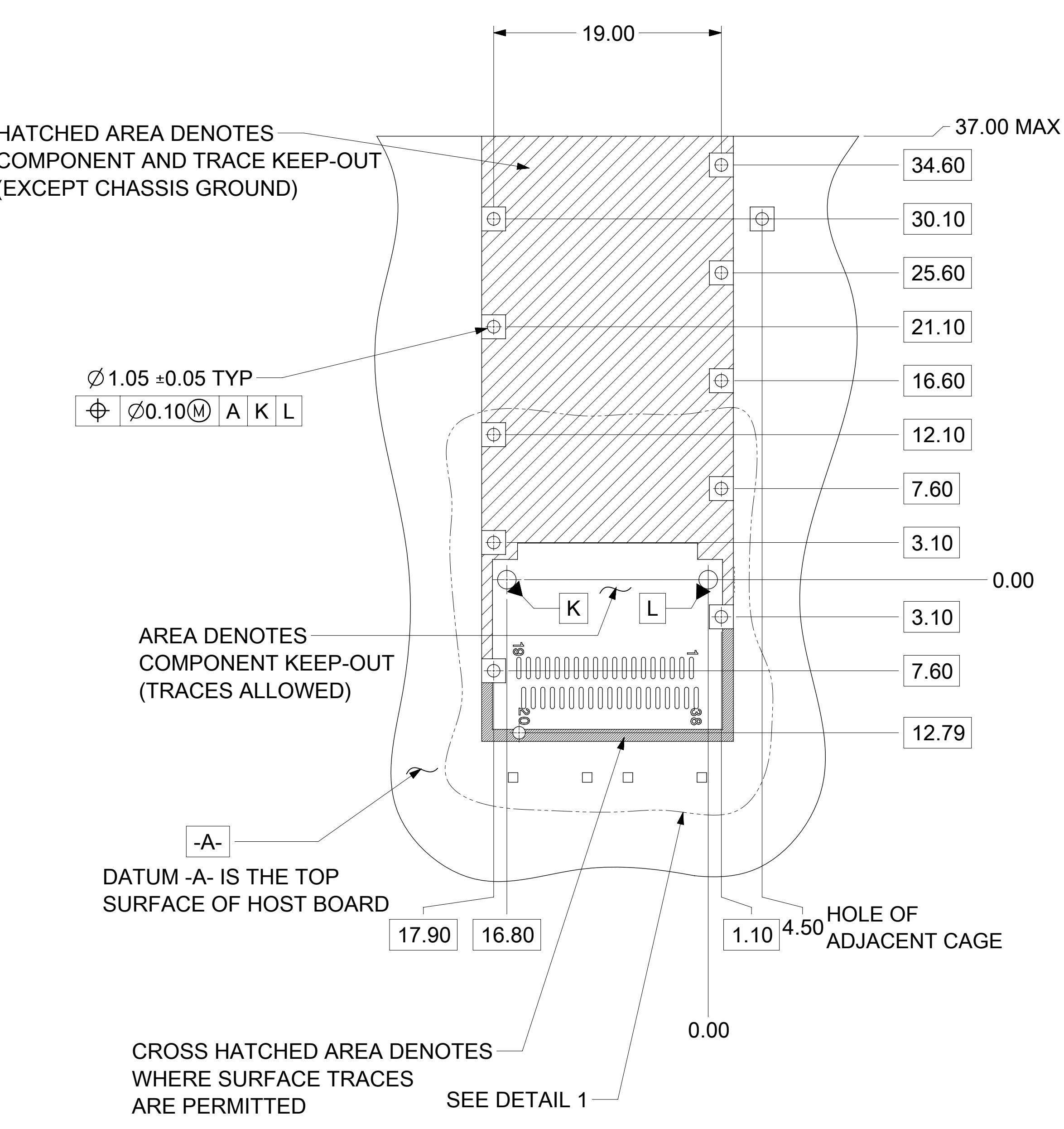

- NOTES:
1. PADS AND VIAS GO TO CHASSIS GROUND. (RECOMMENDED PADS TO BE 2.00mm SQUARE.)
  2. RECOMMENDED THRU HOLE PLATING INCLUDES HASL, OSP, OR IMMERSION (GOLD, SILVER, OR TIN).
  3. CONNECTOR PAD LAYOUT PER SFF-8663 WILL ACCOMODATE MOLEX CONNECTOR SERIES 170432.
  4. NOTED DIMENSIONS ONLY APPLY TO CAGE ASSEMBLIES WITH LIGHT PIPES.

FUNCTIONAL SYMBOLS	THIS DRAWING CONTAINS INFORMATION THAT IS PROPRIETARY TO MOLEX ELECTRONIC TECHNOLOGIES, LLC AND SHOULD NOT BE USED WITHOUT WRITTEN PERMISSION		CURRENT REV DESC: SEE REVISION TABLE	
	FA = 0	mm	SCALE	3.5:1
DIVISIONAL SYMBOLS	GENERAL TOLERANCES (UNLESS SPECIFIED)			
	FC = 0	ANGULAR TOL ± 2.0°		
DIVISIONAL SYMBOLS	4 PLACES	±	EC NO: 698842	
	3 PLACES	±	DRWN: TKUMARKC	2022/02/17
	2 PLACES	± 0.15	CHK'D: TKUMARKC	2022/03/16
	1 PLACE	± 0.25	APPR: JCHIANG	2022/03/28
DIVISIONAL SYMBOLS	0 PLACES	±	INITIAL REVISION:	
	DRAFT WHERE APPLICABLE MUST REMAIN WITHIN DIMENSIONS		DRWN: TKUMARKC	2022/02/17
THIRD ANGLE PROJECTION		DRAWING	SERIES	100014
D-SIZE		MATERIAL NUMBER		1000143200
D-SIZE		CUSTOMER		GENERAL MARKET
D-SIZE		SHEET NUMBER		4 OF 7

# PCB LAYOUT FOR BELLY TO BELLY MOUNTING

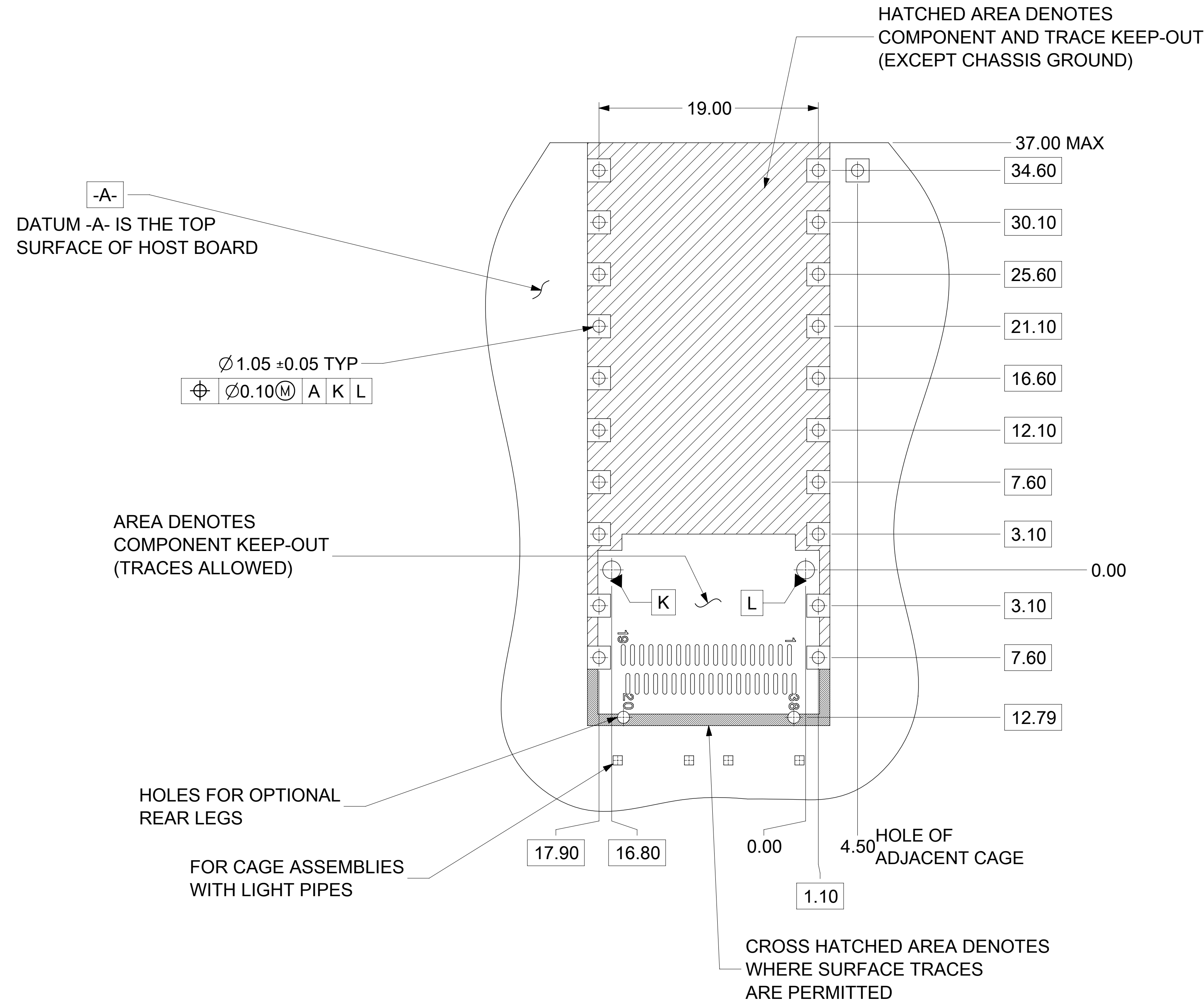

NOTE:  
SEE SHEET 4 FOR  
HOST CONNECTOR DETAIL  
AND LED LOCATION DETAILS

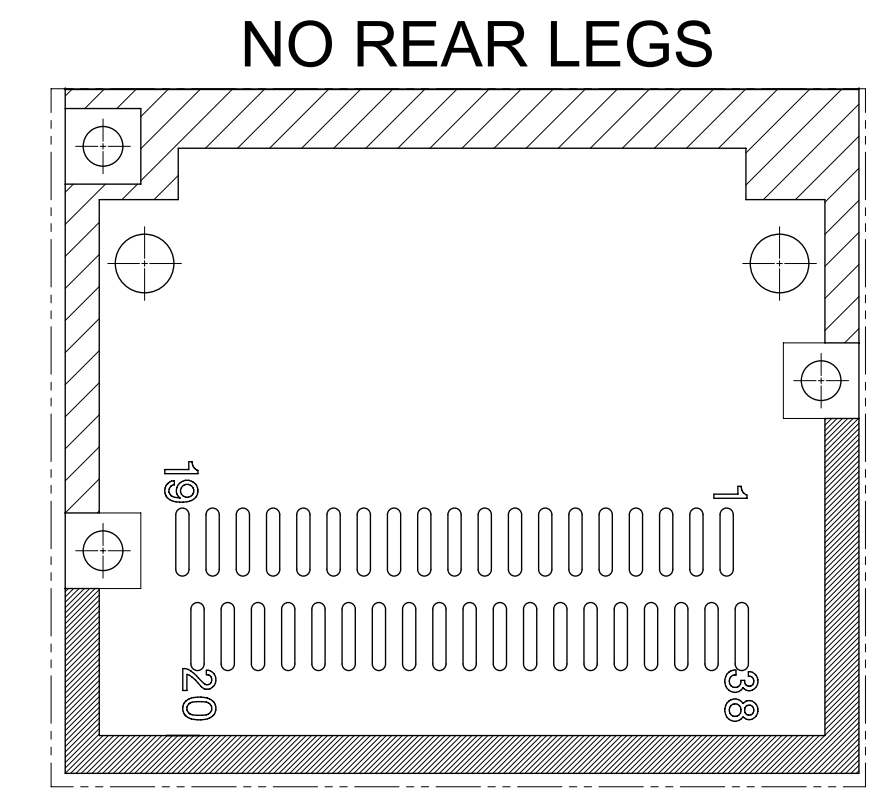

PARTIAL 1  
SCALE 5:1

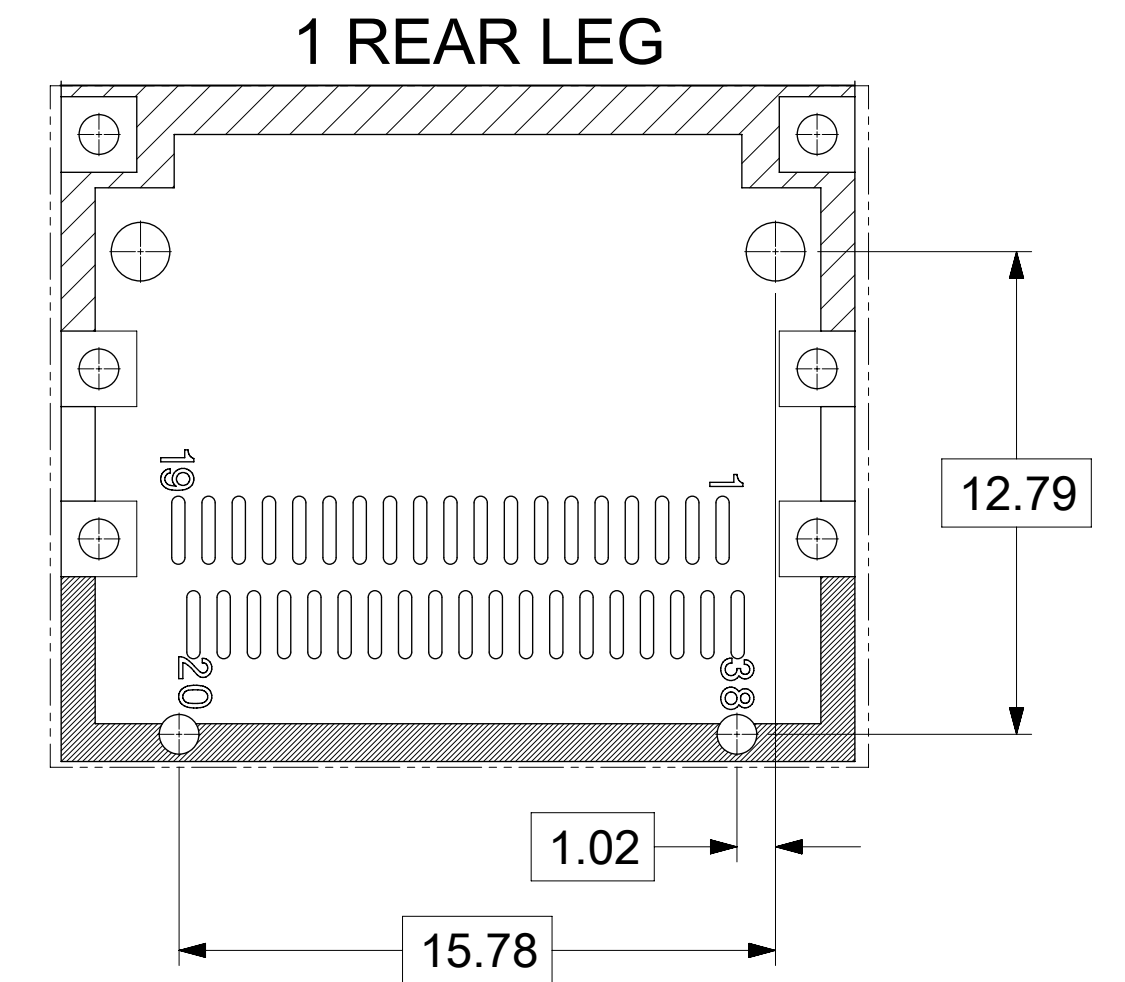

PARTIAL 5  
SCALE 5:1

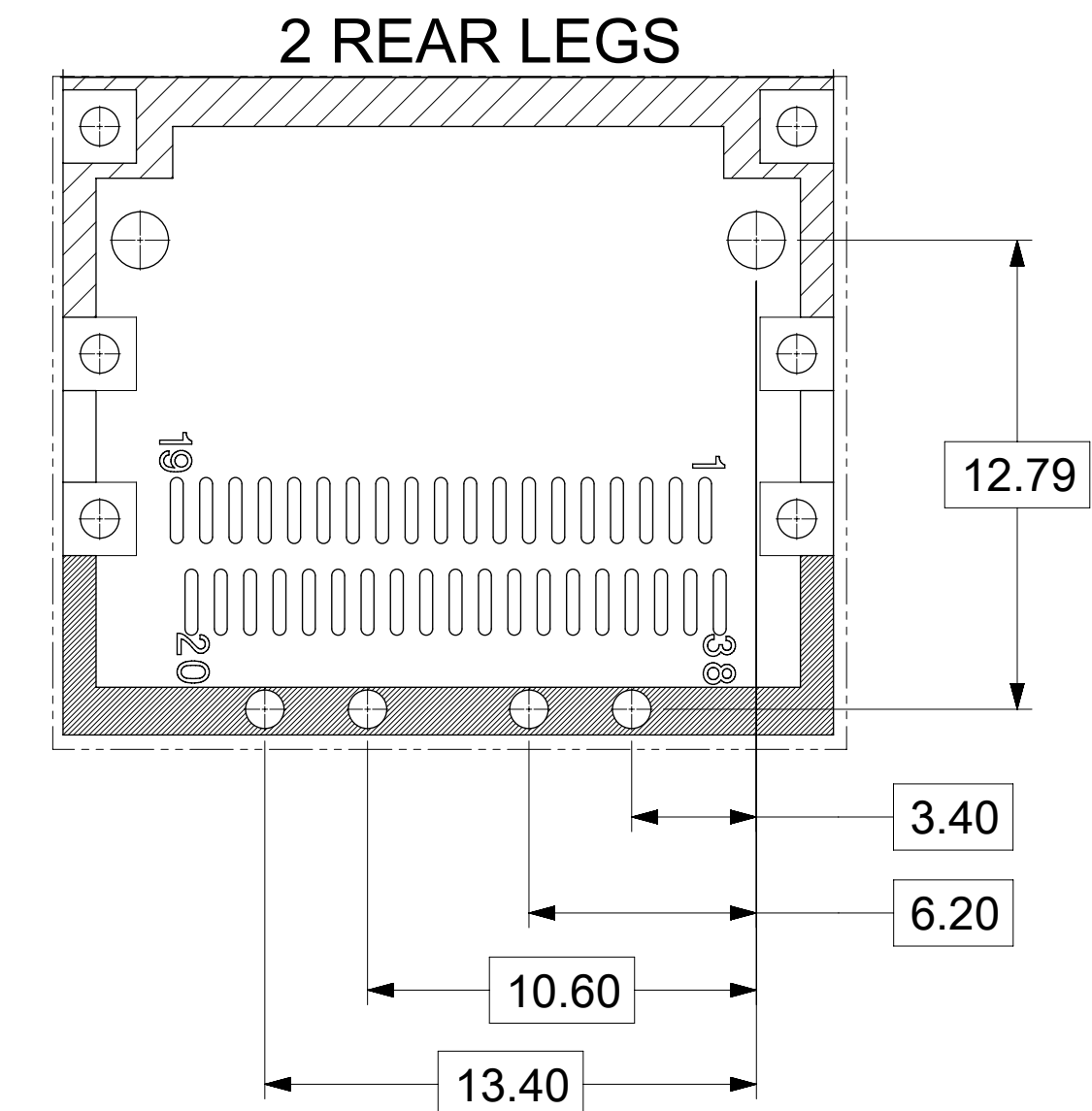

PARTIAL 6  
SCALE 5:1

- NOTES:
1. PADS AND VIAS GO TO CHASSIS GROUND. (RECOMMENDED PADS TO BE 2.00mm SQUARE.)
  2. RECOMMENDED THRU HOLE PLATING INCLUDES HASL, OSP, OR IMMERSION (GOLD, SILVER, OR TIN).
  3. CONNECTOR PAD LAYOUT PER SFF-8663 WILL ACCOMODATE MOLEX CONNECTOR SERIES 170432.

THIS DRAWING CONTAINS INFORMATION THAT IS PROPRIETARY TO MOLEX ELECTRONIC TECHNOLOGIES, LLC AND SHOULD NOT BE USED WITHOUT WRITTEN PERMISSION										
FUNCTIONAL SYMBOLS	DIMENSION UNITS	SCALE	CURRENT REV DESC: SEE REVISION TABLE							
$\nabla_A = 0$	mm	4:1								
$\nabla_C = 0$	GENERAL TOLERANCES (UNLESS SPECIFIED)									
$\nabla_P = 0$	ANGULAR TOL $\pm 2.0^\circ$									
DIVISIONAL SYMBOLS	4 PLACES	$\pm$	EC NO: 698842							
	3 PLACES	$\pm$	DRWN: TKUMARKC 2022/02/17							
	2 PLACES	$\pm 0.15$	CHK'D: TKUMARKC 2022/03/16							
	1 PLACE	$\pm 0.25$	APPR: JCHIANG 2022/03/28							
	0 PLACES	$\pm$	INITIAL REVISION:							
	DRAFT WHERE APPLICABLE MUST REMAIN WITHIN DIMENSIONS		THIRD ANGLE PROJECTION		DRAWING		SERIES		MATERIAL NUMBER	
					D-SIZE		100014		1000143200	
			GENERAL MARKET			CUSTOMER			SHEET NUMBER	
									5 OF 7	

**molex**

ZQSFP+ 1X1 CAGE ASSY'S W/ SUS TAB TYPE  
SPRING FINGER, H/S & L/P OPTIONS

PRODUCT CUSTOMER DRAWING

DOCUMENT NUMBER	DOC TYPE	DOC PART	REVISION
1000143200	PSD	ASY	A

### BEZEL AND BOARD POSITION DIMENSIONS FOR BELLY TO BELLY MOUNTING

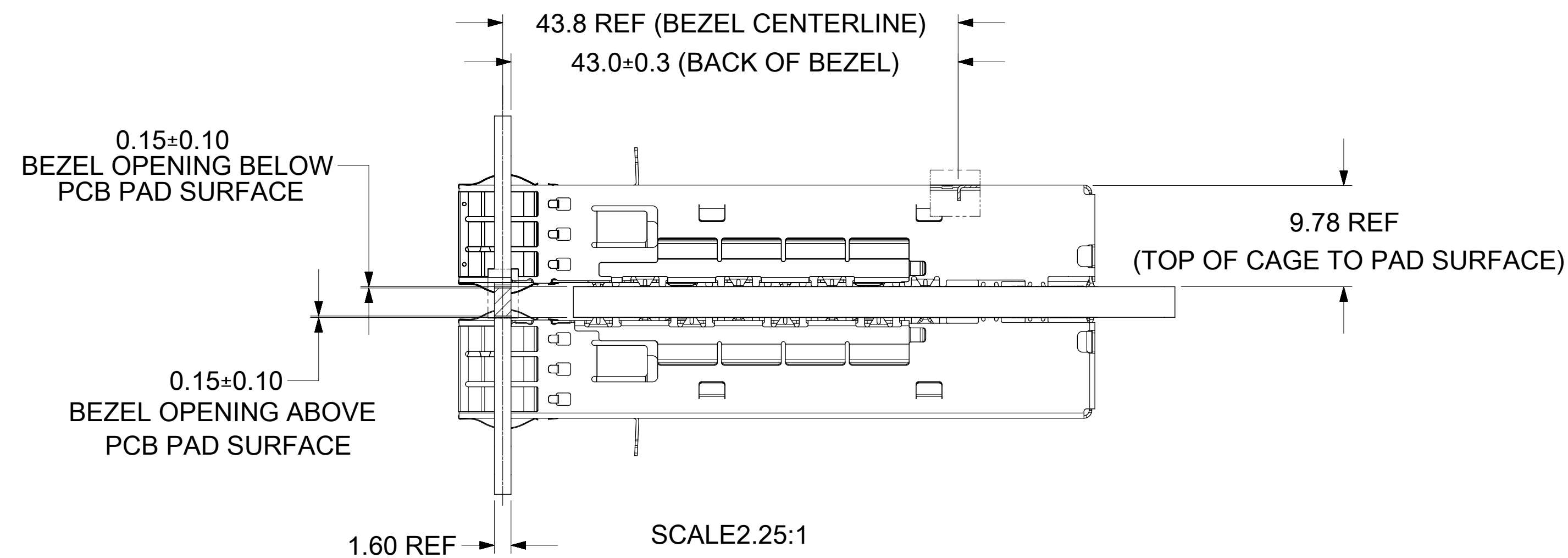

### SINGLE LIGHT PIPE

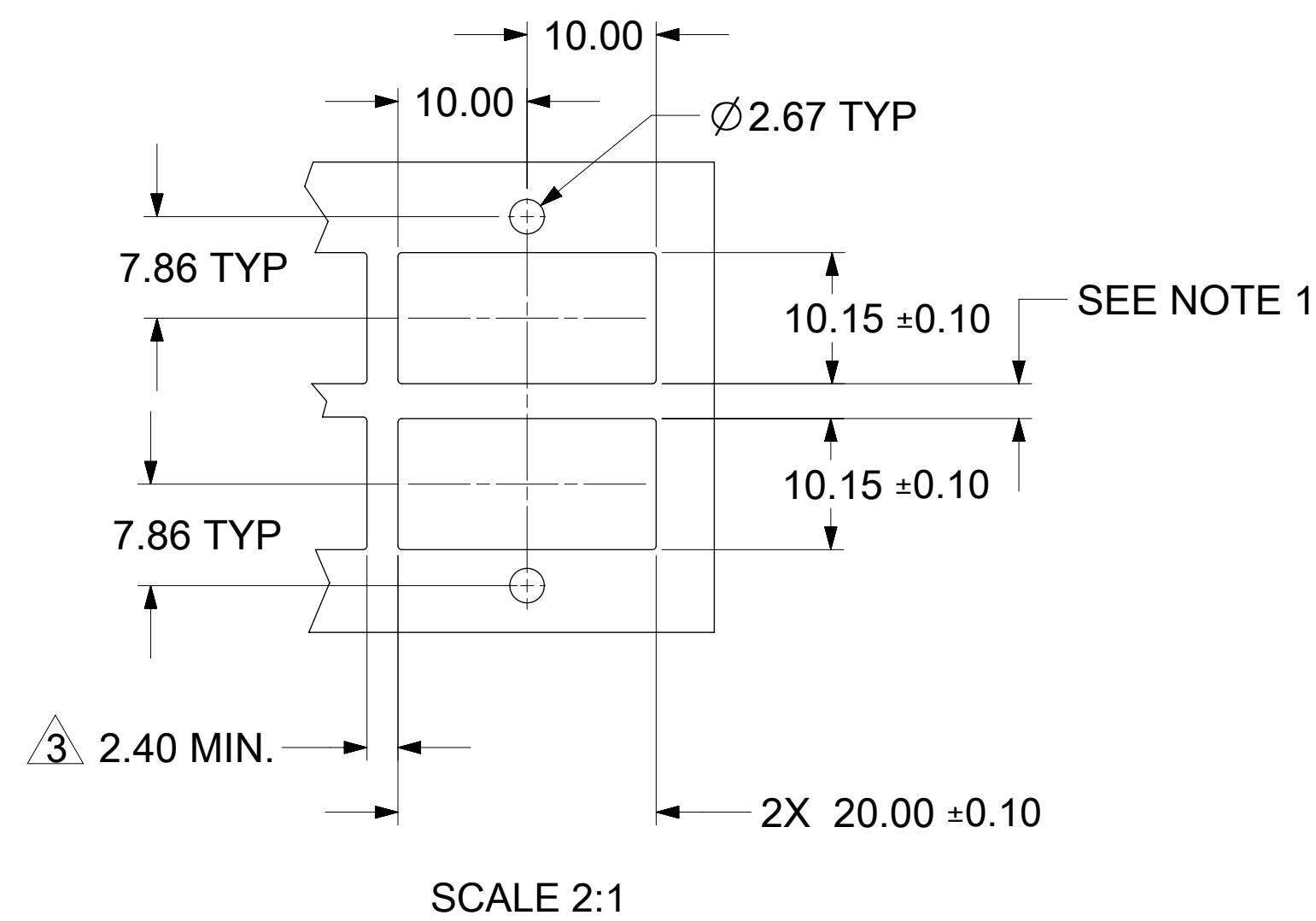

### DUAL/QUAD LIGHT PIPE

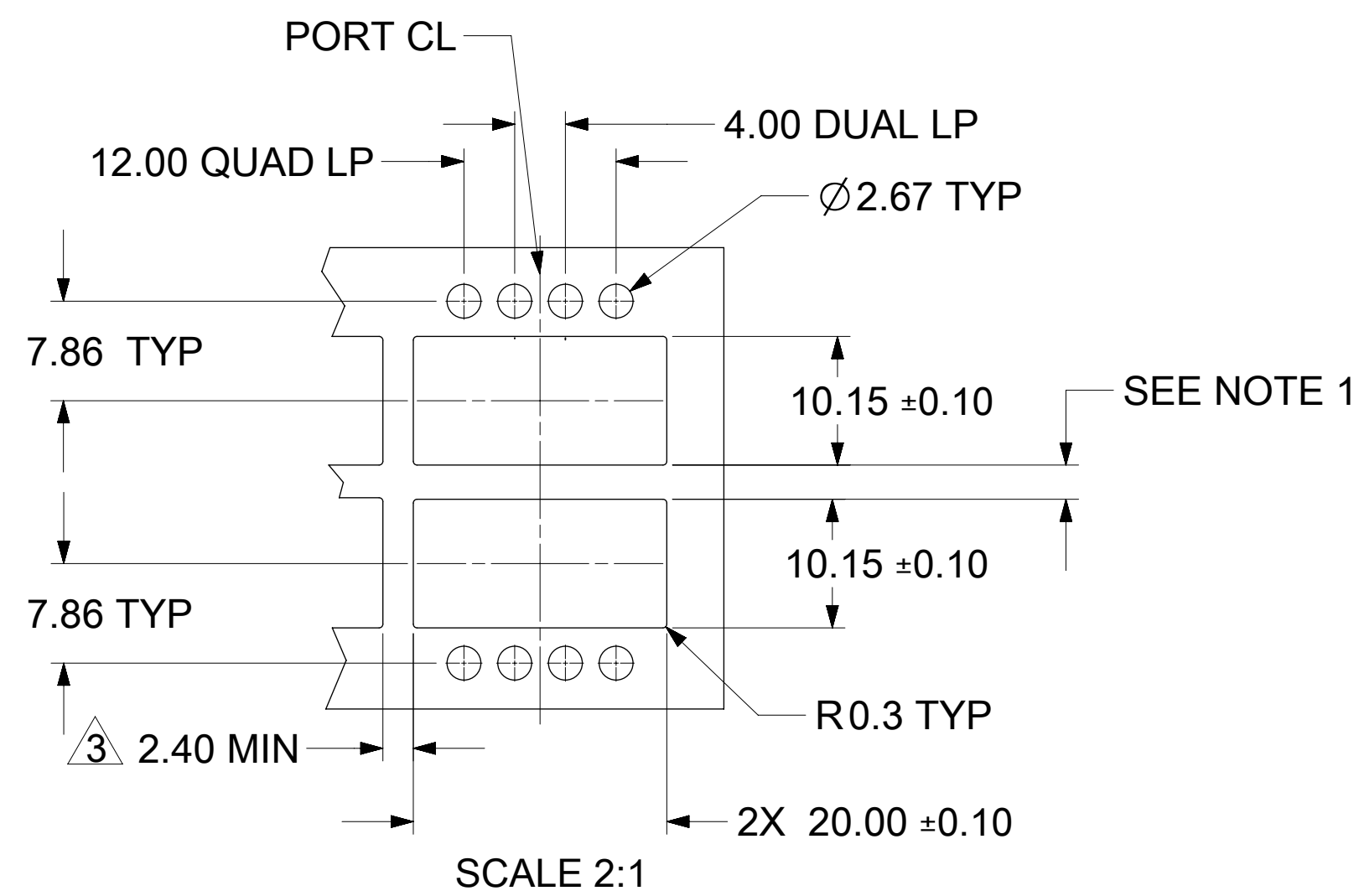

- NOTE:
- PCB THICKNESS VARIATION MUST BE CONSIDERED WHEN DETERMINING BEZEL OPENING LOCATION.
  - NOTED DIMENSIONS ONLY APPLY TO CAGE ASSEMBLIES WITH LIGHT PIPES.
  - THIS DIMENSION IS FOR REFERENCE ONLY. USER CAN MODIFY UT DEPENDS ON APPLICATION. (THIS DIMENSION VARIES BASED ON DISTANCE OF "HOLE OF ADJACENT CAGE" ON PCB LAYOUT.)

### BEZEL AND BOARD POSITION DIMENSIONS FOR SINGLE SIDE MOUNTING

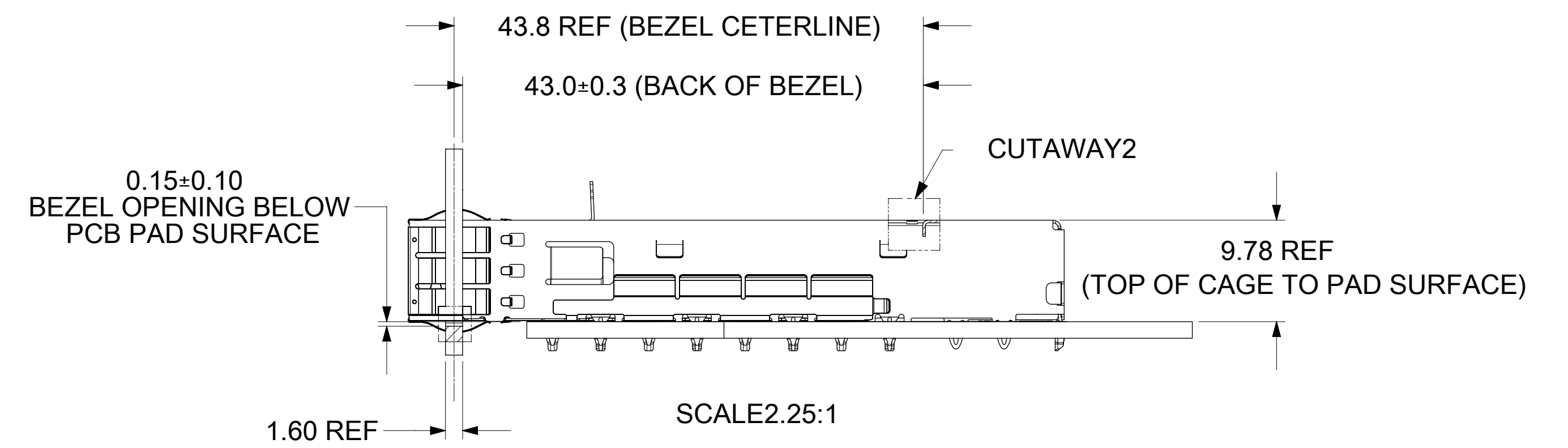

### SINGLE LIGHT PIPE

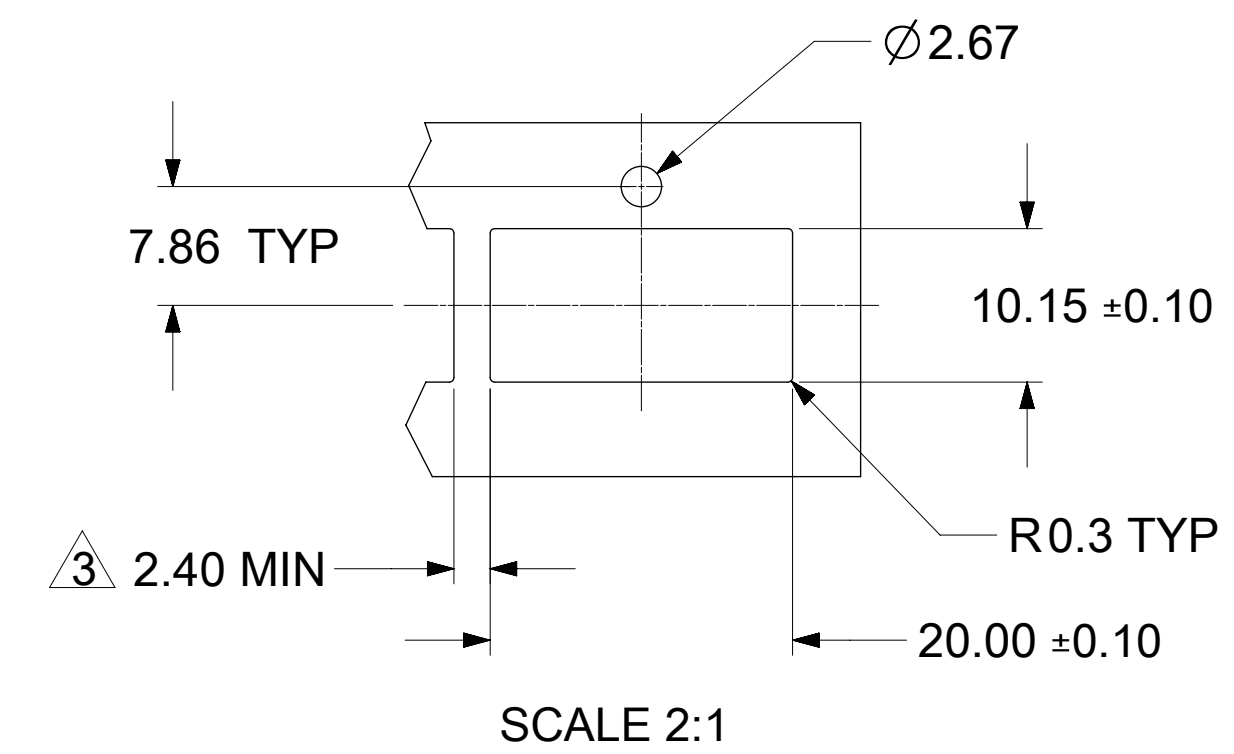

### DUAL/QUAD LIGHT PIPE

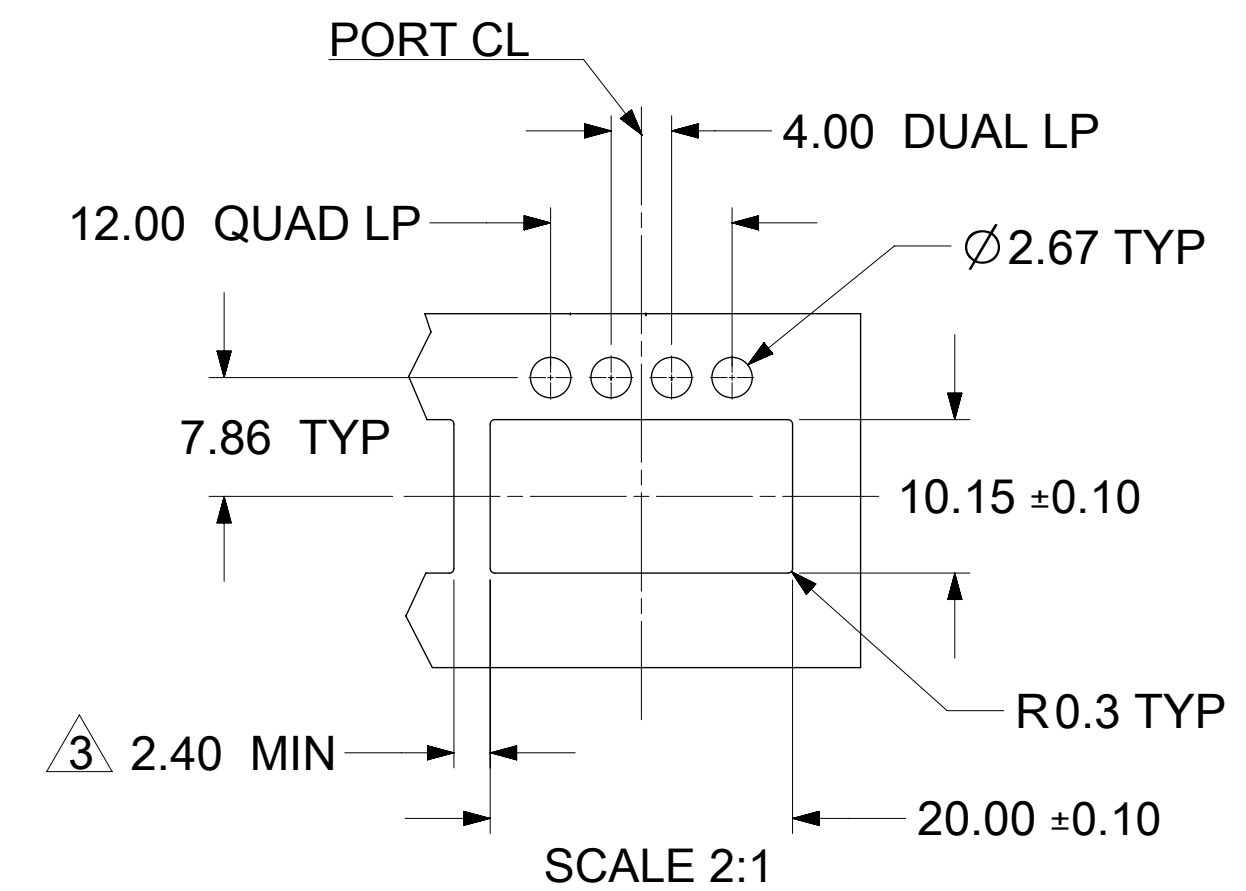

FUNCTIONAL SYMBOLS	THIS DRAWING CONTAINS INFORMATION THAT IS PROPRIETARY TO MOLEX ELECTRONIC TECHNOLOGIES, LLC AND SHOULD NOT BE USED WITHOUT WRITTEN PERMISSION		CURRENT REV DESC: SEE REVISION TABLE		<b>molex</b>			
	FA = 0	mm	SCALE 2.5:1					
DIVISIONAL SYMBOLS	GENERAL TOLERANCES (UNLESS SPECIFIED)		EC NO: 698842		ZQSFP+ 1X1 CAGE ASSY'S W/ SUS TAB TYPE SPRING FINGER, H/S & L/P OPTIONS			
	FC = 0	ANGULAR TOL ± 2.0°		DRWN: TKUMARKC 2022/02/17				
FUNCTIONAL SYMBOLS	FP = 0	4 PLACES	±	CHK'D: TKUMARKC 2022/03/16	PRODUCT CUSTOMER DRAWING			
		3 PLACES	±	APPR: JCHIANG 2022/03/28				
		2 PLACES	± 0.15	INITIAL REVISION:				
		1 PLACE	± 0.25	DRWN: TKUMARKC 2022/02/17				
	0 PLACES	±	APPR: JCHIANG 2022/03/28	DOCUMENT NUMBER	DOC TYPE	DOC PART	REVISION	
DRAFT WHERE APPLICABLE MUST REMAIN WITHIN DIMENSIONS		THIRD ANGLE PROJECTION		DRAWING	SERIES	MATERIAL NUMBER	CUSTOMER	SHEET NUMBER
				D-SIZE	100014	1000143200	GENERAL MARKET	6 OF 7

REV	DATE	DESCRIPTION
A	2022/02/17	INITIAL RELEASE

FUNCTIONAL SYMBOLS										THIS DRAWING CONTAINS INFORMATION THAT IS PROPRIETARY TO MOLEX ELECTRONIC TECHNOLOGIES, LLC AND SHOULD NOT BE USED WITHOUT WRITTEN PERMISSION									
FA = 0		mm		SCALE		1:1		CURRENT REV DESC: SEE REVISION TABLE											
FC = 0		GENERAL TOLERANCES (UNLESS SPECIFIED)		ANGULAR TOL ± 2.0°		4 PLACES ±		3 PLACES ±		2 PLACES ± 0.15		1 PLACE ± 0.25		0 PLACES ±		EC NO: 698842		DRWN: TKUMARKC 2022/02/17	
FD = 0		DIVISIONAL SYMBOLS		DRAFT WHERE APPLICABLE MUST REMAIN WITHIN DIMENSIONS		THIRD ANGLE PROJECTION		DRAWING		SERIES		MATERIAL NUMBER		CUSTOMER		SHEET NUMBER		PSD ASY A	
								D-SIZE		100014		1000143200		GENERAL MARKET		7 OF 7			
ZQSFP+ 1X1 CAGE ASSY'S W/ SUS TAB TYPE SPRING FINGER, H/S & L/P OPTIONS										molex									
PRODUCT CUSTOMER DRAWING										DOCUMENT NUMBER DOC TYPE DOC PART REVISION									

DOCUMENT STATUS	P1	RELEASE DATE	2022/03/28	08:56:17
-----------------	----	--------------	------------	----------