

THIS DRAWING IS UNPUBLISHED. RELEASED FOR PUBLICATION
 © COPYRIGHT 2011 BY TE CONNECTIVITY. ALL RIGHTS RESERVED.

REVISIONS					
P	LTR	DESCRIPTION	DATE	DWN	APVD
C2		REVISED PER ECR-18-012076	28DEC18	DZ	SL

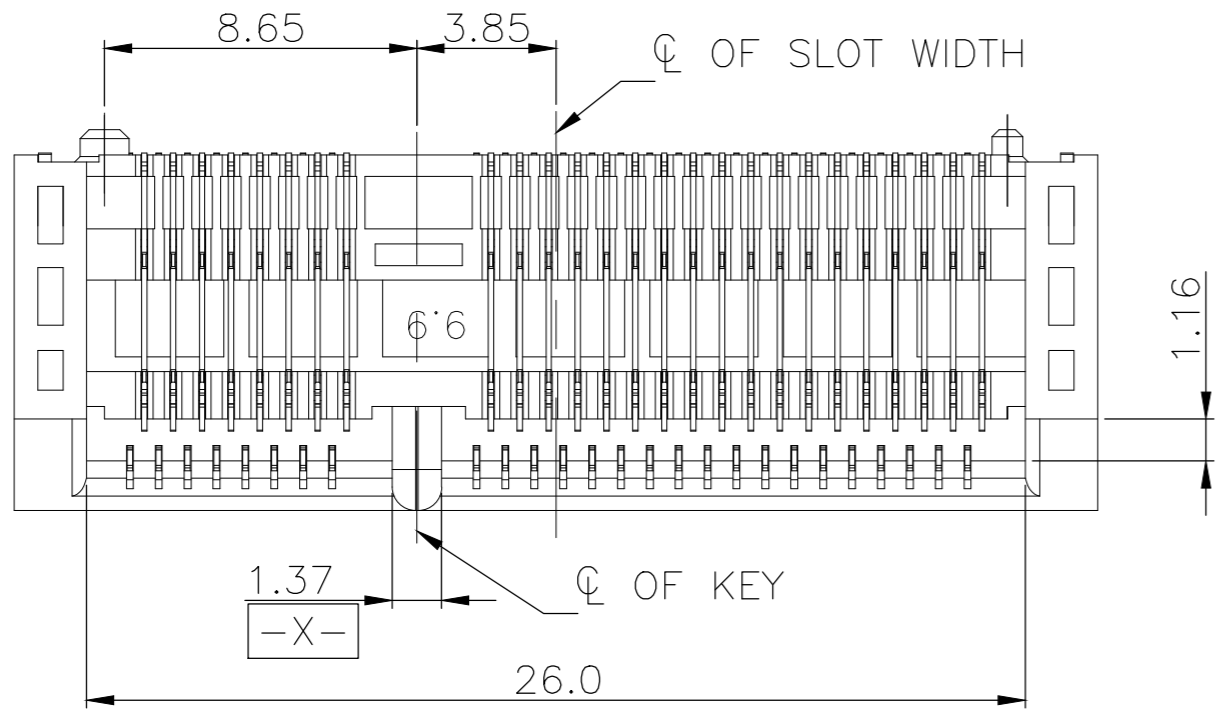

NOTES:

- MATERIAL:
HOUSING: LCP WITH 30% GF, UL 94V-0, BLACK COLOR.
CONTACTS: PHOSPHOR BRONZE.
PEGS: BRASS.
- FINISH:
CONTACTS: (SEE TABLE) GOLD PLATED ON CONTACT AREA, GOLD FLASH ON SOLDER AREA, WITH ENTIRE CONTACT UNDERPLATED 1.27mm [50m"] MIN. NICKEL.
PEGS: 3.048mm [120m"] MIN. MATTE-TIN OVER 1.27mm [50m"] MIN. NICKEL.
- REFLOW SOLDER CAPABLE TO 260° PER TEC-109-201, CONDITION B.

CONNECTOR PIN-OUT DEFINITIONS

PIN#	NAME	PIN#	NAME
51	RESERVED	52	+3.3Vaux
49	RESERVED	50	GND
47	RESERVED	48	+1.5V
45	RESERVED	46	LED_WPAN#
43	GND	44	LED_WLAN#
41	+3.3Vaux	42	LED_WWAN#
39	+3.3Vaux	40	GND
37	GND	38	USB_D+
35	GND	36	USB_D-
33	PETp0	34	GND
31	PETn0	32	SMB_DATA
29	GND	30	SMB_CLK
27	GND	28	+1.5V
25	PERp0	26	GND
23	PERn0	24	+3.3Vaux
21	GND	22	PERST#
19	RESERVED* (UIM_C4)	20	W_DISABLE#
17	RESERVED* (UIM_C8)	18	GND

MECHANICAL KEY

15	GND	16	UIM_VPP
13	REFCLK+	14	UIM_RESET
11	REFCLK-	12	UIM_CLK
9	GND	10	UIM_DATA
7	CLKREQ#	8	UIM_PWR
5	COEX2	6	1.5V
3	COEX1	4	GND
1	WAKE#	2	3.3Vaux

* RESERVED FOR FUTURE UIM INTERFACE (IF NEEDED)

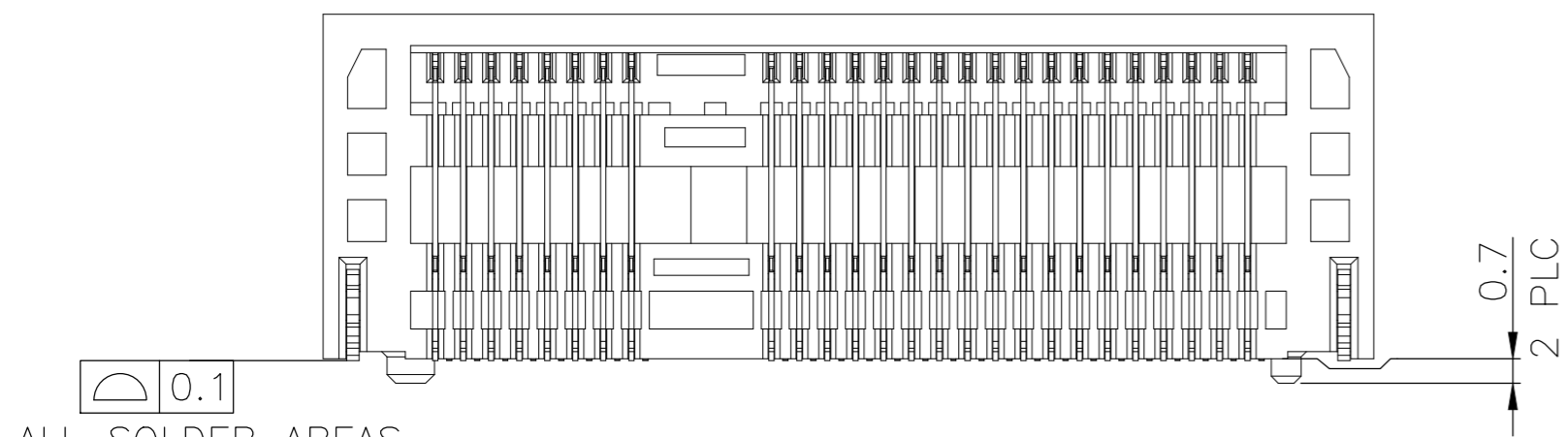
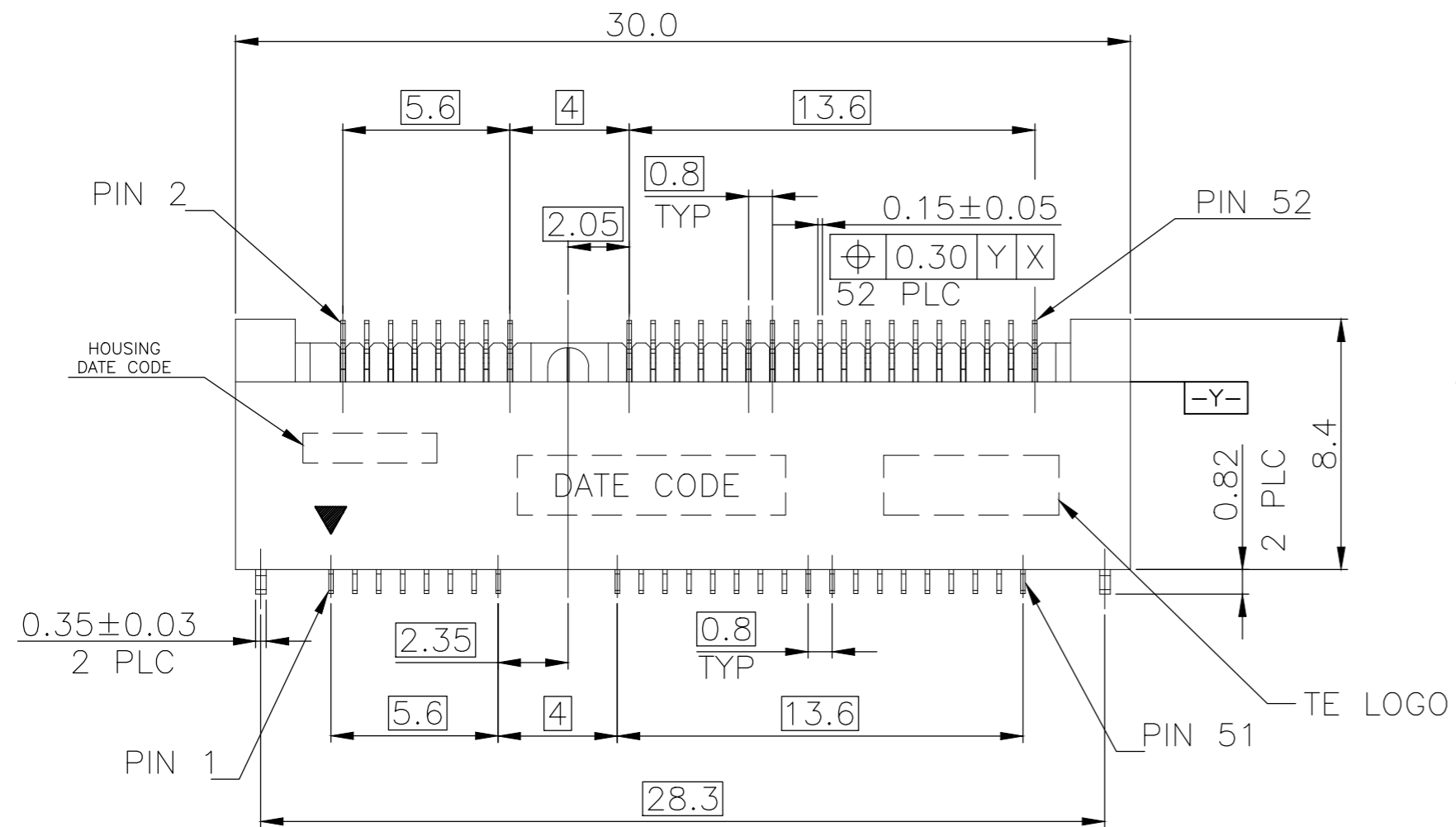
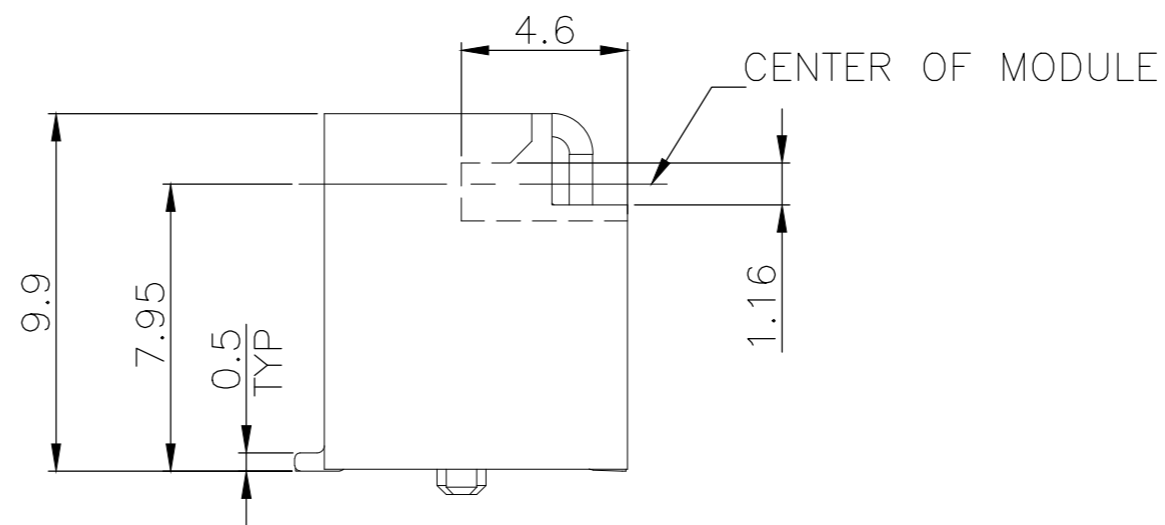
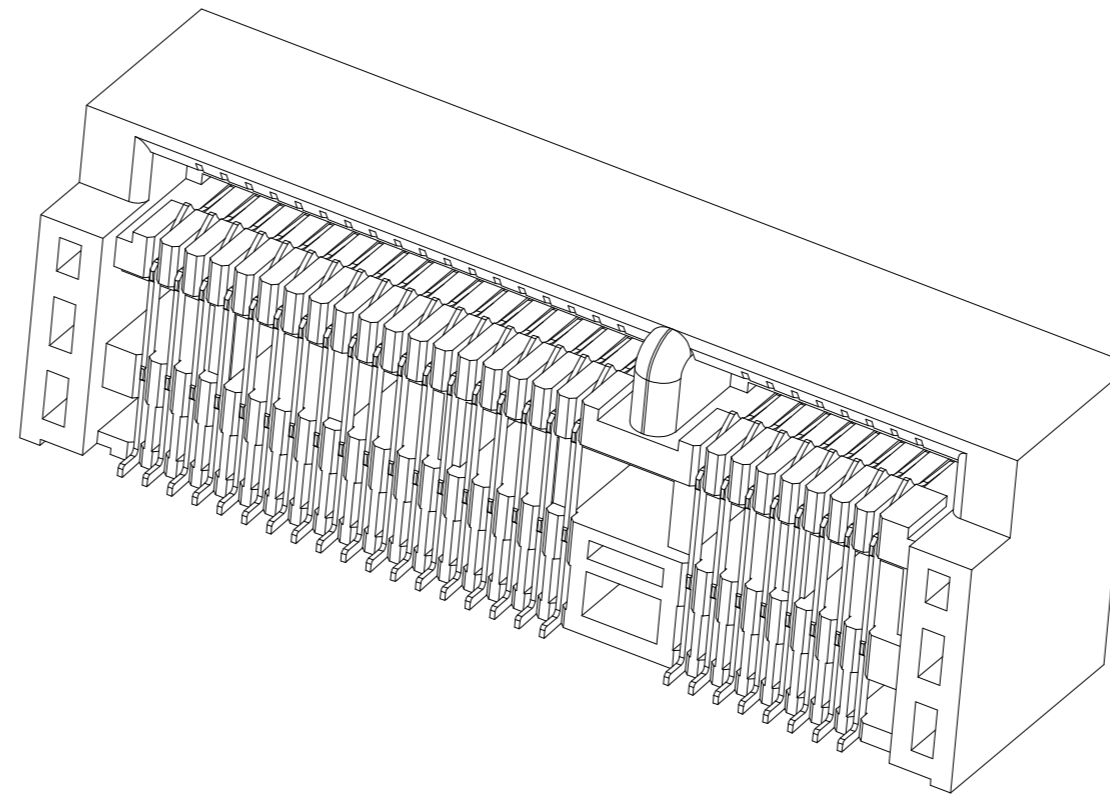

ALL SOLDER AREAS

Ø1.35

THIS DRAWING IS A CONTROLLED DOCUMENT.

DIMENSIONS:	TOLERANCES UNLESS OTHERWISE SPECIFIED:
mm	0 PLC ± -
	1 PLC ± 0.3
	2 PLC ± 0.2
	3 PLC ± -
	4 PLC ± -
	ANGLES ± 3°
MATERIAL	FINISH
SEE NOTE	SEE NOTE

DWN	A. WU	28DEC2009		PCI EXPRESS MINI CARD CONNECTOR, 9.9 MM HEIGHT		
CHK	S. CHIEN	28DEC2009				
APVD	W. KODAMA	28DEC2009				
PRODUCT SPEC	108-99102					
APPLICATION SPEC			SIZE	CAGE CODE	DRAWING NO	RESTRICTED TO
WEIGHT	3.22 GRAMS	A2	00779	C=2041216		
CUSTOMER DRAWING		SCALE		SHEET	1 of 4	REV
						C2

0.254µm [10µ"]	2041216-1
MIN. GOLD THICKNESS	PART NUMBER

THIS DRAWING IS UNPUBLISHED. RELEASED FOR PUBLICATION
 © COPYRIGHT 2011 BY TE CONNECTIVITY. ALL RIGHTS RESERVED.

REVISIONS					
P	LTR	DESCRIPTION	DATE	DWN	APVD
		SEE SHEET 1	-	-	-

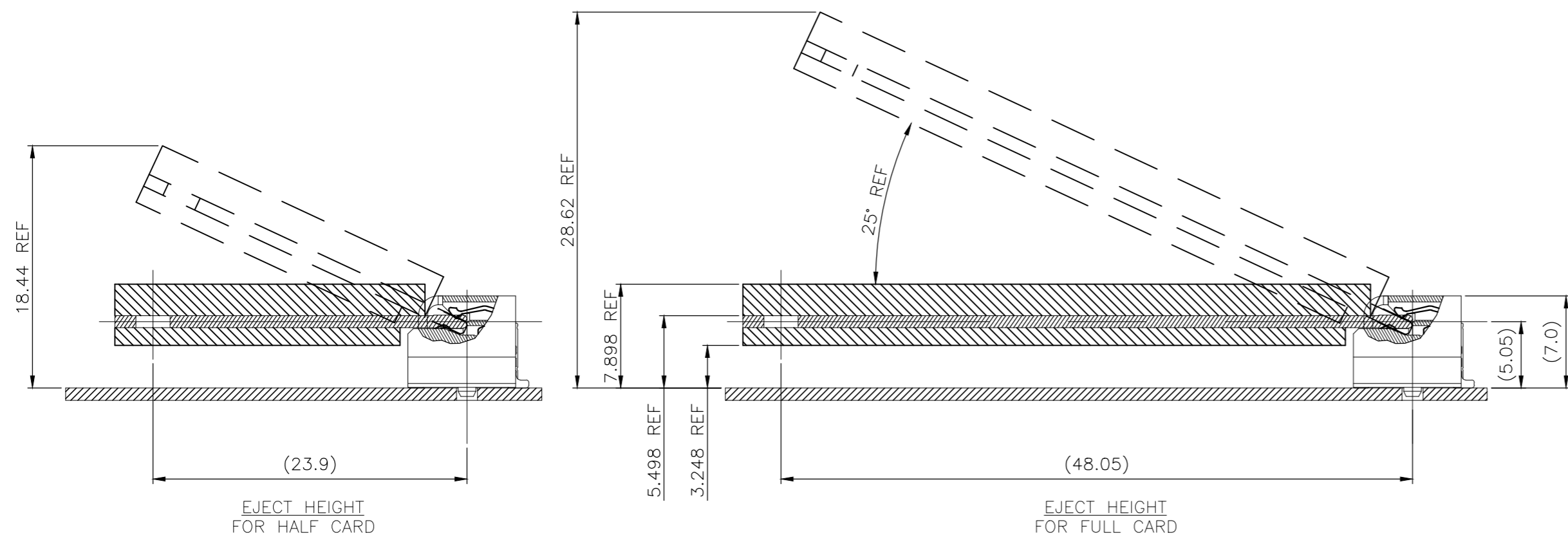

COMPONENT KEEP OUT AREA FOR CARD HOLD DOWN SOLUTION

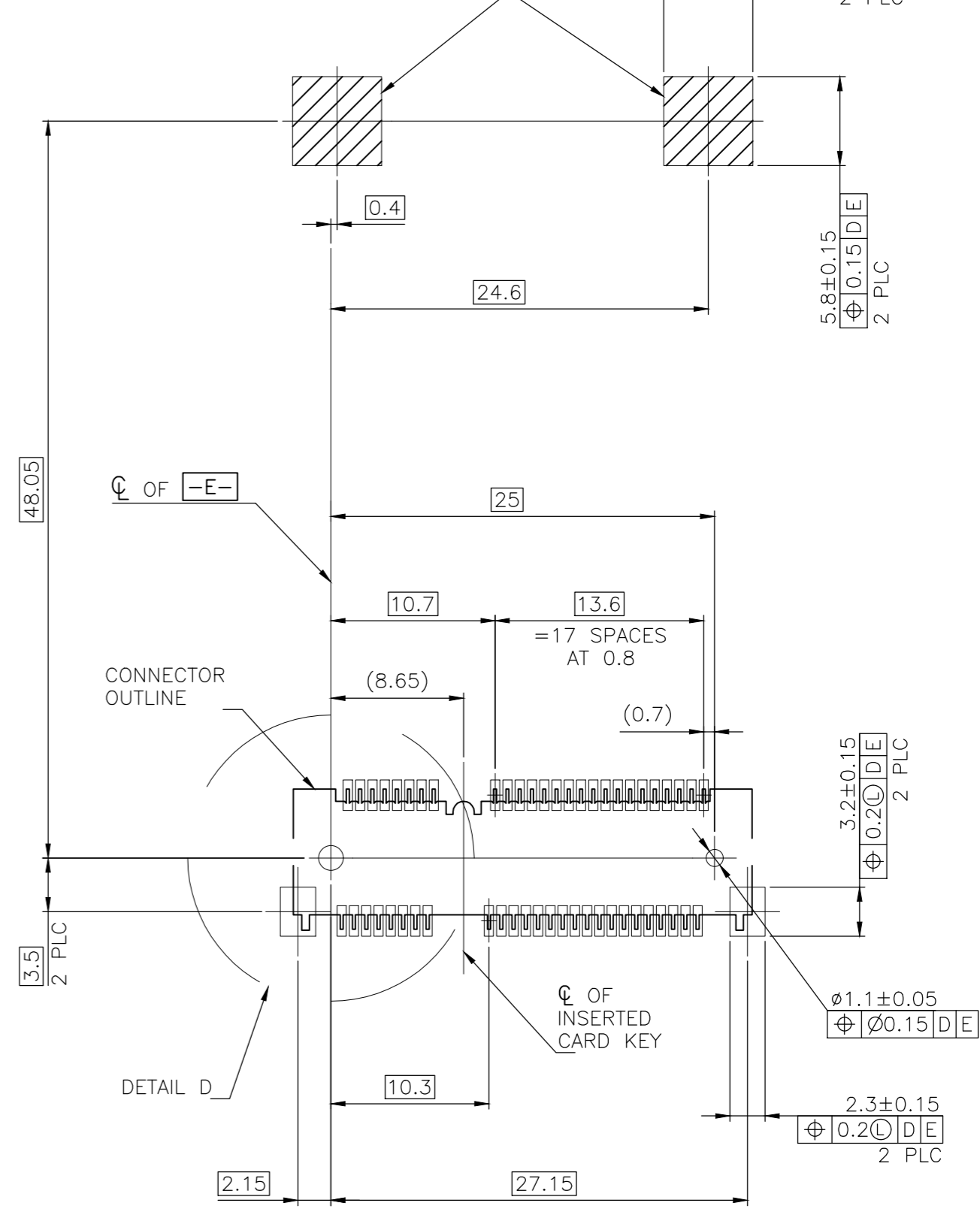

-D- IS THE TOP SURFACE OF PCB.
 RECOMMENDED P.C. BOARD PATTERN LAYOUT FOR FULL CARD CONNECTOR (TOP VIEW)

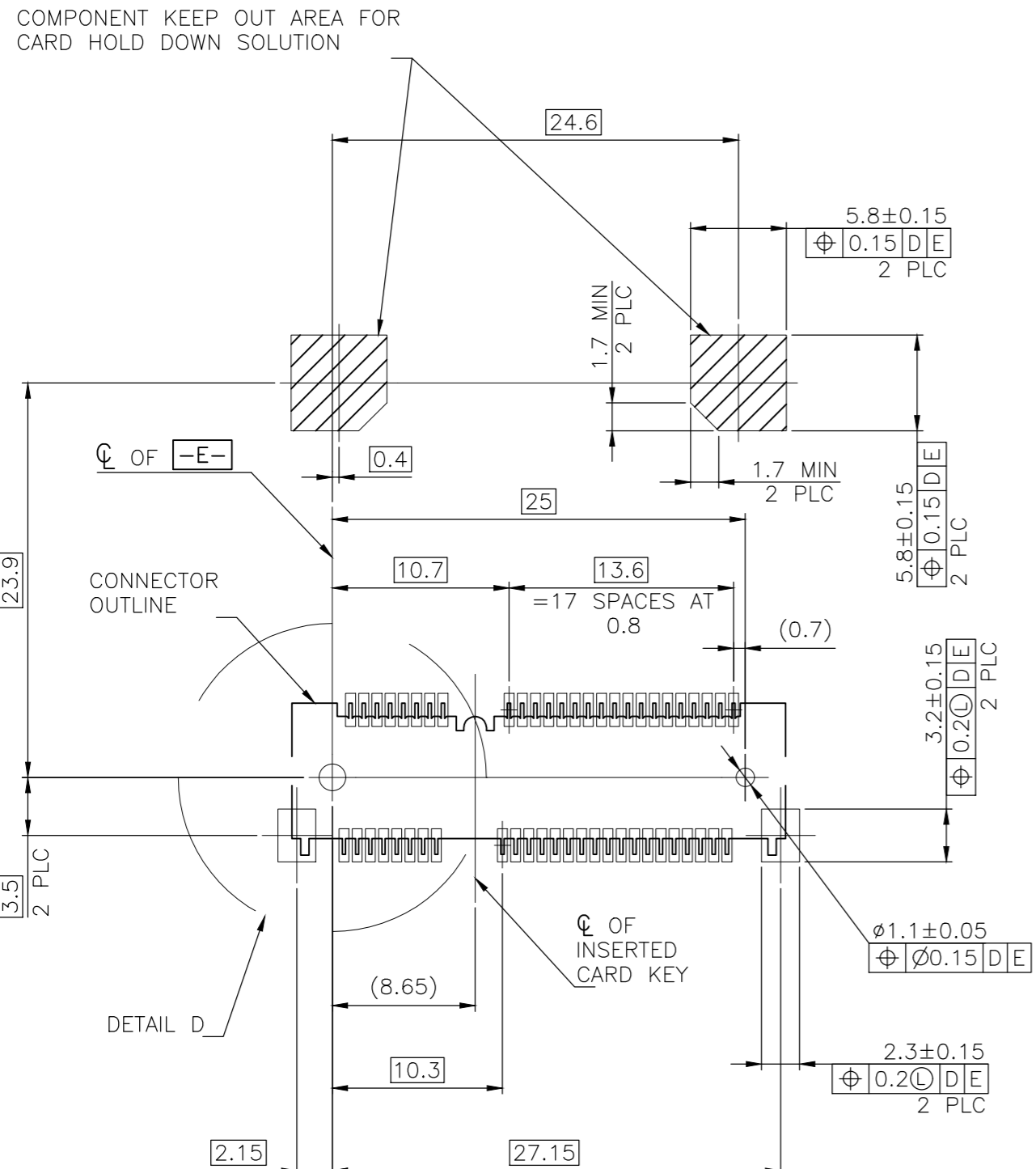

-D- IS THE TOP SURFACE OF PCB.
 RECOMMENDED P.C. BOARD PATTERN LAYOUT FOR HALF CARD CONNECTOR (TOP VIEW)

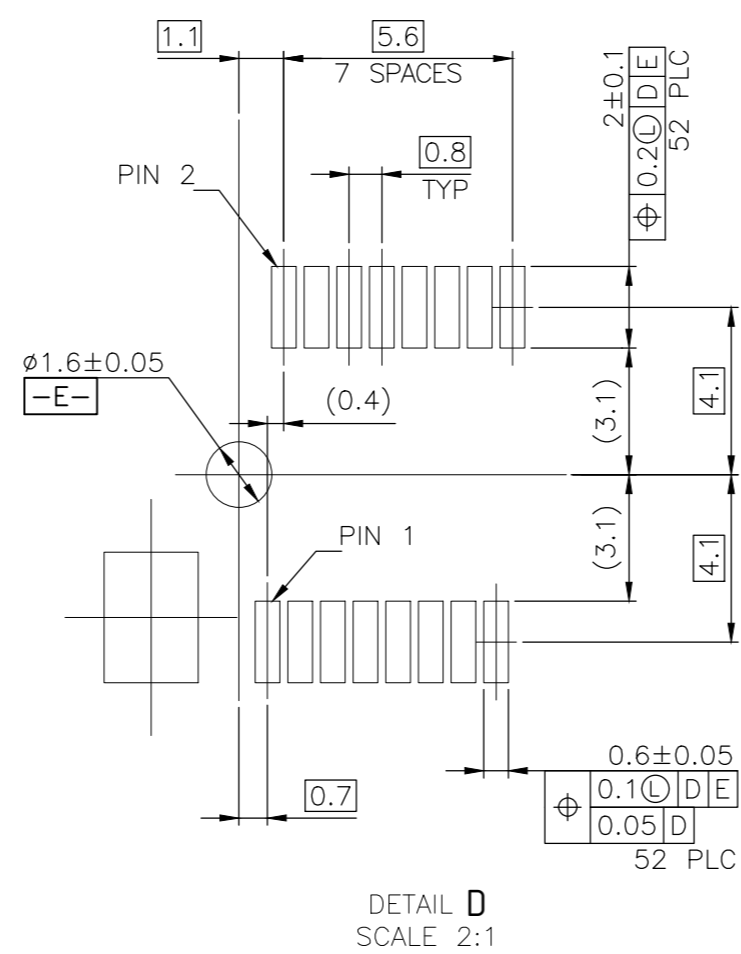

THIS DRAWING IS A CONTROLLED DOCUMENT.		DWN	TE Connectivity		
DIMENSIONS: mm		CHK	NAME		
TOLERANCES UNLESS OTHERWISE SPECIFIED:		APVD	PCI EXPRESS MINI CARD CONNECTOR, 9.9 MM HEIGHT		
0 PLC ±		PRODUCT SPEC	SIZE	CAGE CODE	DRAWING NO
1 PLC ±		APPLICATION SPEC	A2	00779	C=2041216
2 PLC ±		WEIGHT	RESTRICTED TO		
3 PLC ±		FINISH	CUSTOMER DRAWING		
4 PLC ±			SCALE	SHEET	REV
ANGLES ±			-	2 OF 4	C2

THIS DRAWING IS UNPUBLISHED. RELEASED FOR PUBLICATION
 © COPYRIGHT 2011 BY TE CONNECTIVITY. ALL RIGHTS RESERVED.

REVISIONS				
P	LTR	DESCRIPTION	DATE	APVD
		SEE SHEET 1	-	-

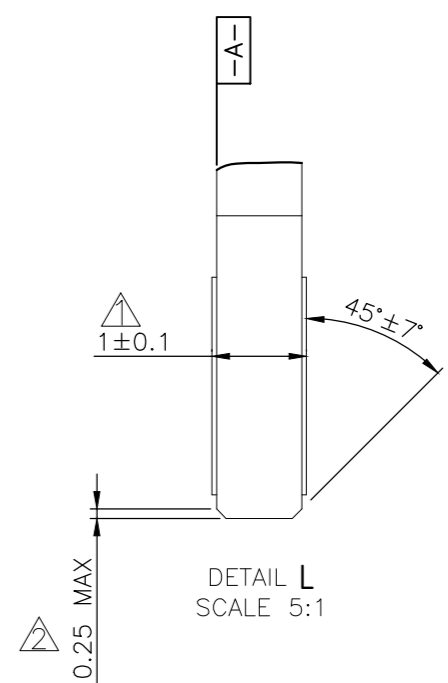
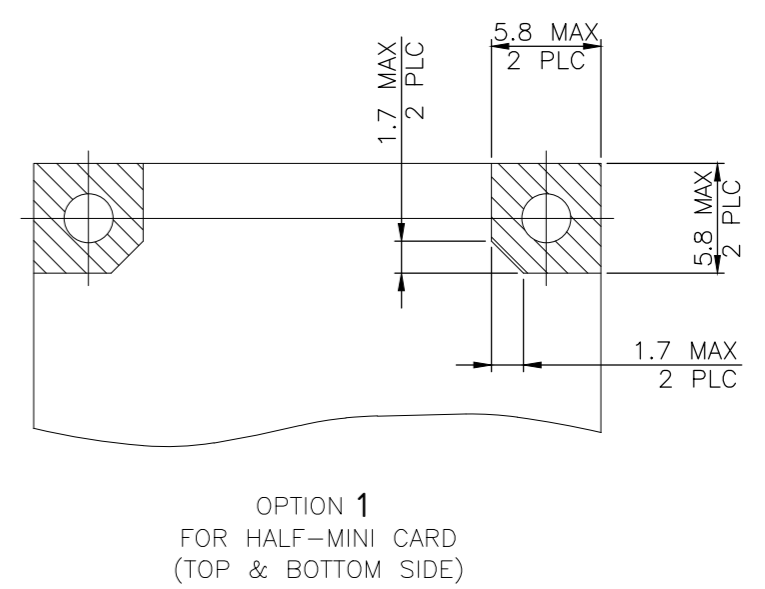
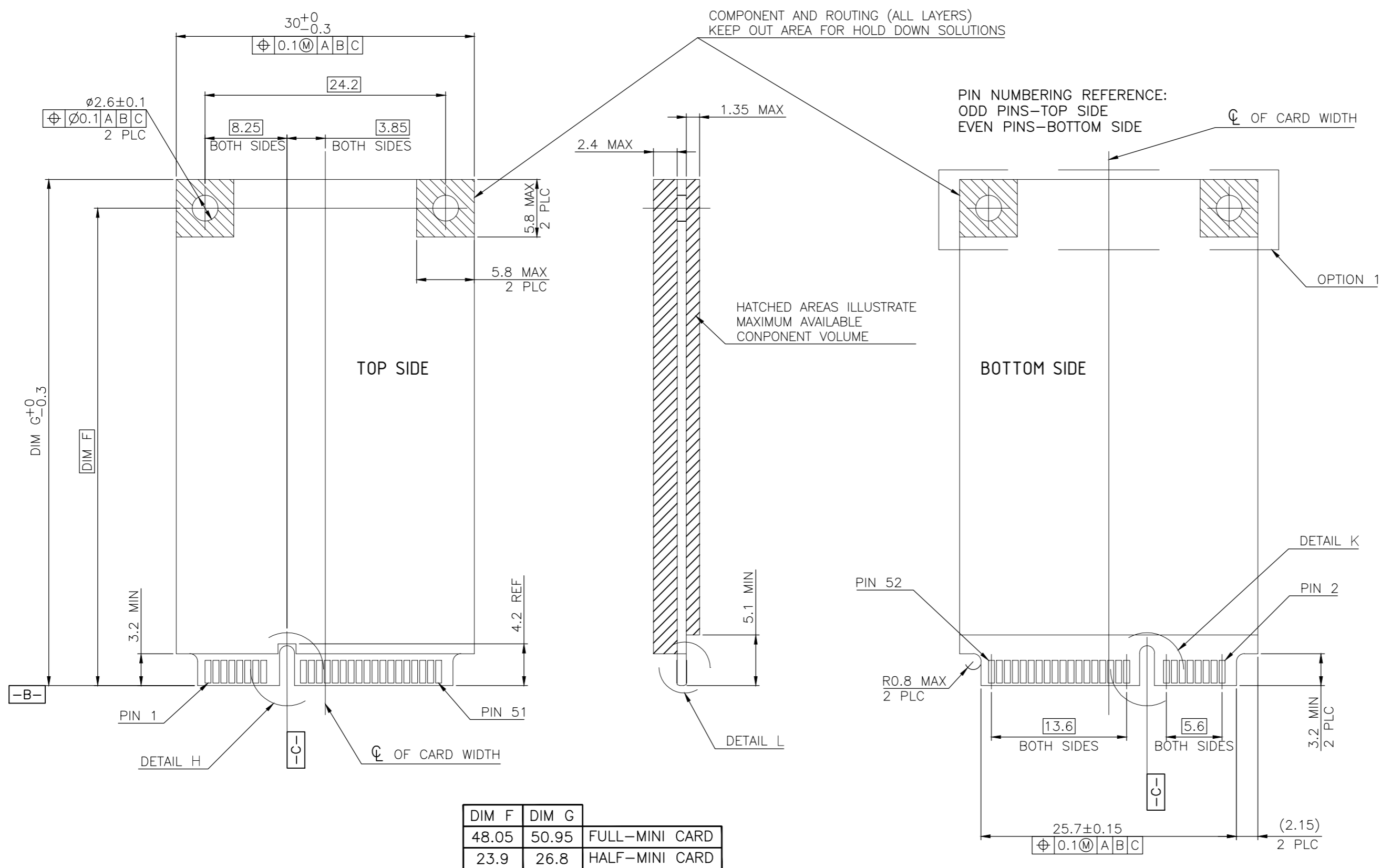

DIM F	DIM G	
48.05	50.95	FULL-MINI CARD
23.9	26.8	HALF-MINI CARD

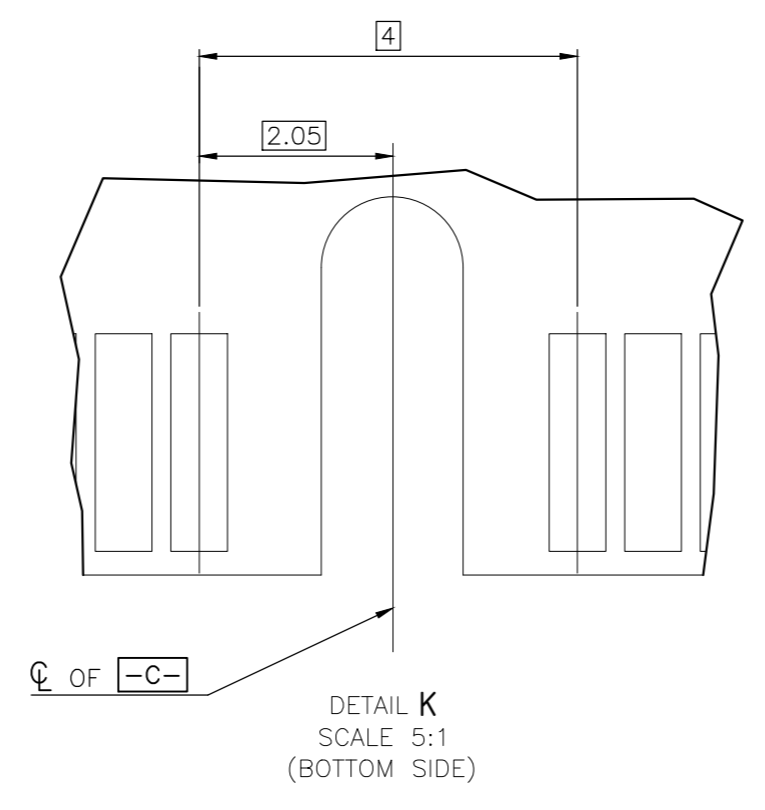
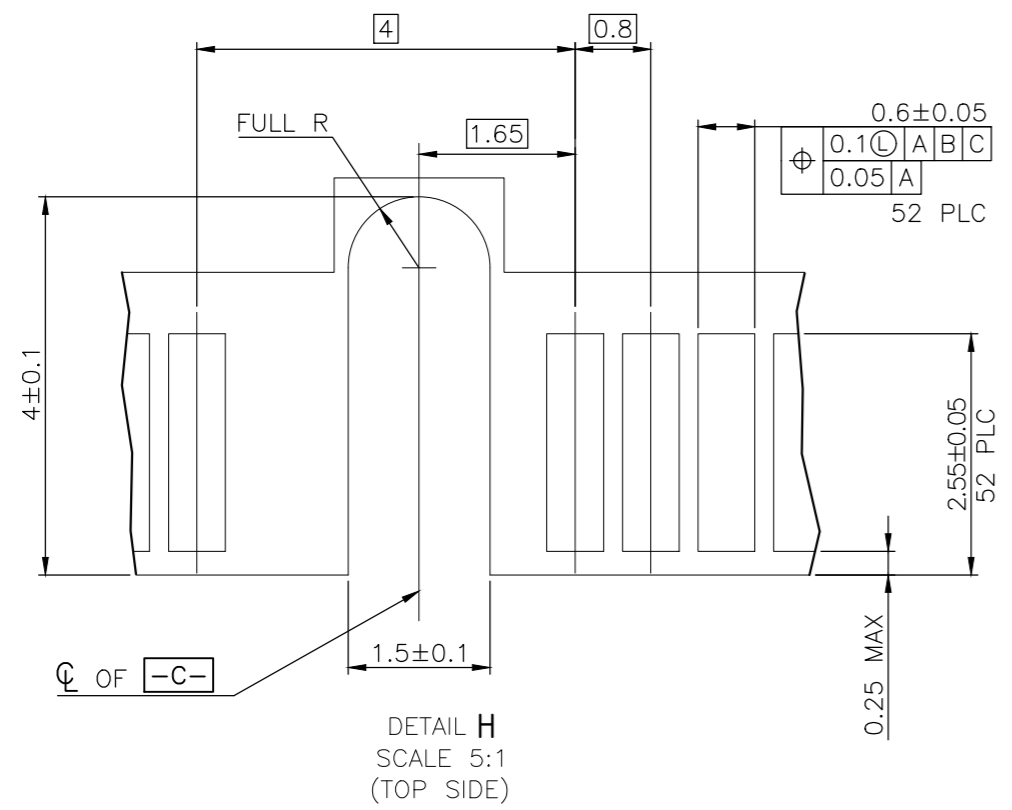

- NOTES:
- △ CARD THICKNESS APPLIES ACROSS TABS AND INCLUDES PLATING AND/OR METALLIZATION.
 - △ EDGE BEVEL MUST BE PRESENT AND FREE OF CUTTING BURRS FROM PCB AND CONTACT MATERIALS.

THIS DRAWING IS A CONTROLLED DOCUMENT.		DWN	TE Connectivity	
DIMENSIONS: mm		CHK	NAME	
TOLERANCES UNLESS OTHERWISE SPECIFIED:		APVD	PCI EXPRESS MINI CARD CONNECTOR, 9.9 MM HEIGHT	
0 PLC ±		PRODUCT SPEC	SIZE	CAGE CODE
1 PLC ±		APPLICATION SPEC	A2	00779
2 PLC ±		WEIGHT	DRAWING NO	RESTRICTED TO
3 PLC ±		CUSTOMER DRAWING	C=2041216	-
4 PLC ±		SCALE	SHEET	REV
ANGLES ±		-	3 OF 4	C2
FINISH				

THIS DRAWING IS UNPUBLISHED. RELEASED FOR PUBLICATION
 © COPYRIGHT 2011 BY TE CONNECTIVITY. ALL RIGHTS RESERVED.

REVISIONS				
P	LTR	DESCRIPTION	DATE	APVD
		SEE SHEET 1	-	-

NOTES:

- MATERIAL:
 BOX: FIBREBOARD, CORRUGATED, DOUBLE WALL.
 COVER TAPE: POLYSTYRENES, TRANSPARENT COLOR.
 CARRIER TAPE: POLYSTYRENES, TRANSPARENT COLOR.
 REEL: HIPS, BLUE COLOR.
 BAG: POLYETHYLENES, TRANSPARENT .
- EACH BAG SHALL BE INCLUDED DESICCANT.
- PEELING STRENGTH: 0.1 ~ 1.3 N (10 ~ 130 GRAMS).
- PEELING SPEED: 300 mm/min.

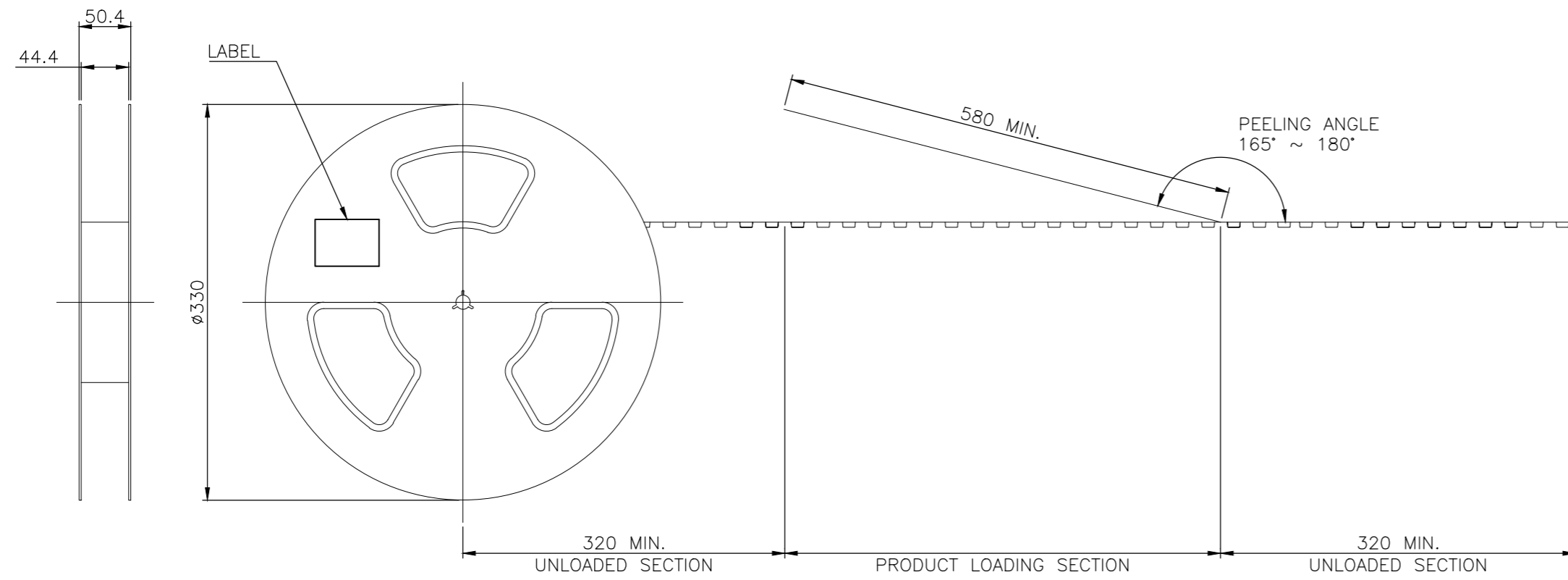

USER DIRECTION OF UNREELING

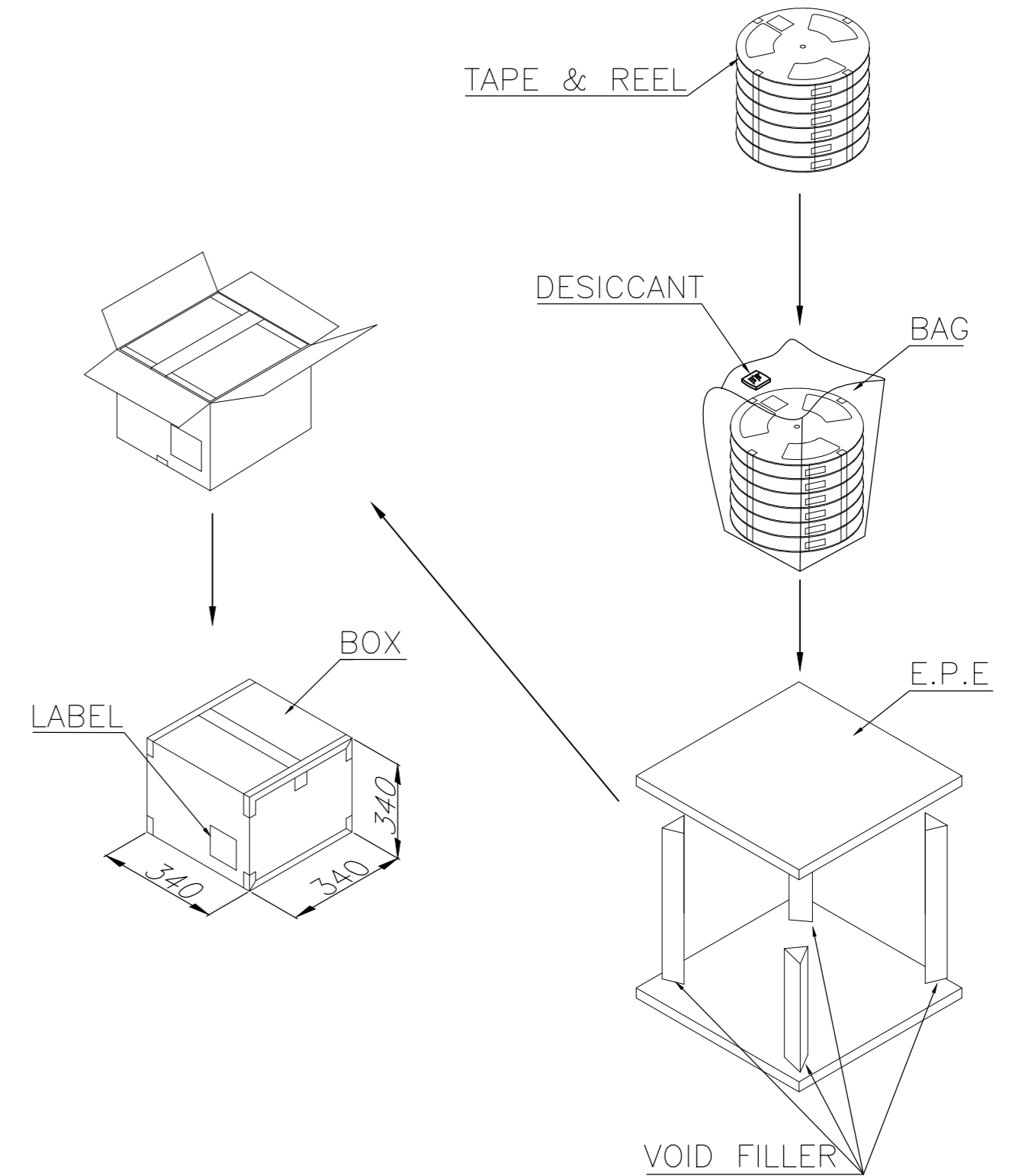
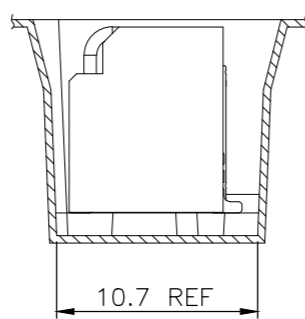
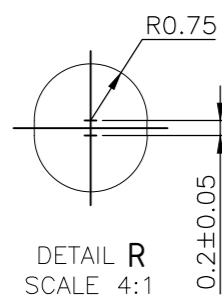
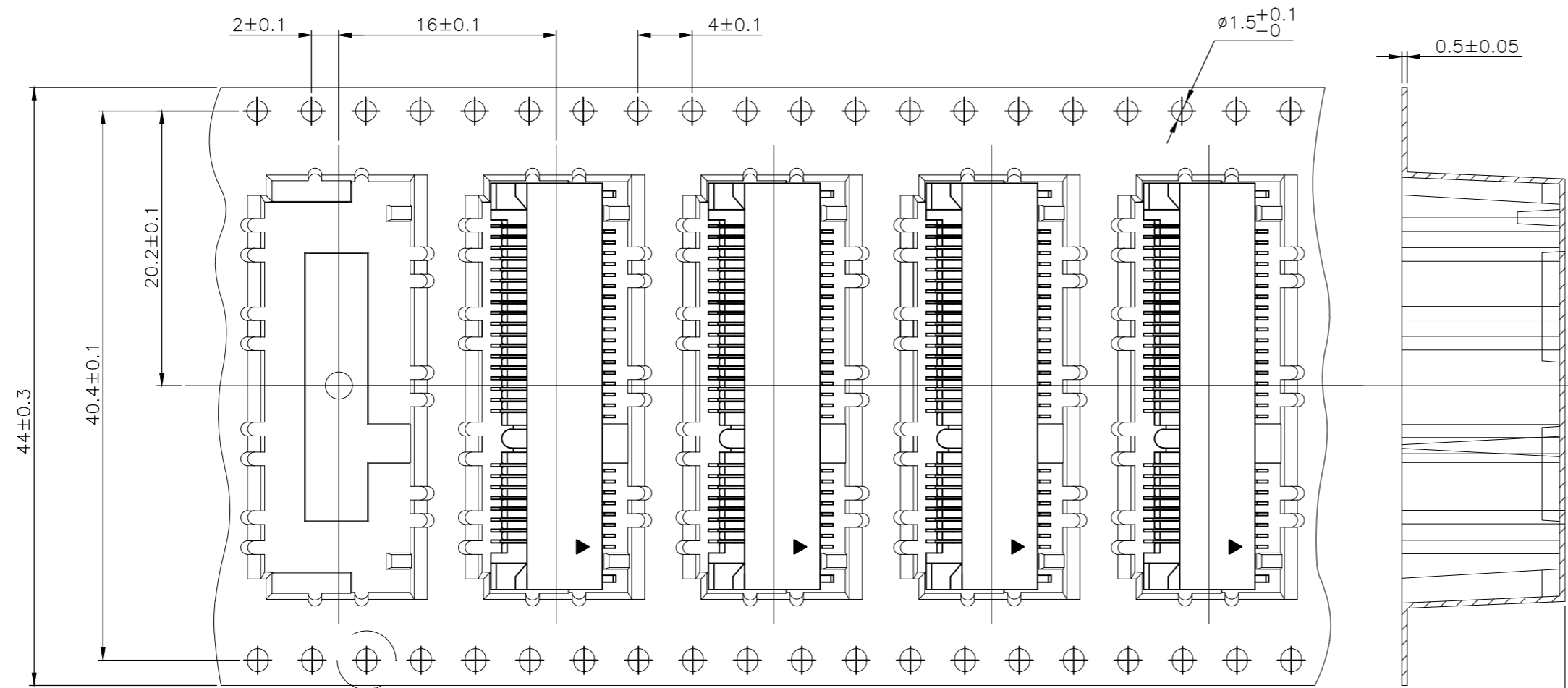

10.31 Kg	5.31 Kg	350	6	2100
GROSS WEIGHT	NET WEIGHT	PCS/TAPE	REELS/BOX	PCS/BOX

THIS DRAWING IS A CONTROLLED DOCUMENT.		DWN	-		
DIMENSIONS: mm		CHK	-		
TOLERANCES UNLESS OTHERWISE SPECIFIED:		APVD	-		
0 PLC ±		PRODUCT SPEC	-		
1 PLC ±		APPLICATION SPEC	-		
2 PLC ±		WEIGHT	-		
3 PLC ±		CUSTOMER DRAWING	-		
4 PLC ±		SCALE	-		
ANGLES ±		SHEET	4 of 4		
FINISH ±		REV	C2		

TE Connectivity		NAME		RESTRICTED TO	
PCI EXPRESS MINI CARD CONNECTOR, 9.9 MM HEIGHT		SIZE		-	
A2		CAGE CODE		-	
00779		DRAWING NO		-	
C=2041216		SCALE		-	