

# AVR-Ready2™

Manual

*All Mikroelektronika's development systems feature a large number of peripheral modules expanding microcontroller's range of application and making the process of program testing easier. In addition to these modules, it is also possible to use numerous additional modules linked to the development system through the I/O port connectors. Some of these additional modules can operate as stand-alone devices without being connected to the microcontroller.*

Additional Board

 **MikroElektronika**

SOFTWARE AND HARDWARE SOLUTIONS FOR EMBEDDED WORLD ...making it simple

## AVR-Ready2 Additional Board

The AVR-Ready2 additional board enables a .hex code to be quickly and easily loaded into AVR microcontrollers by using the AVRprog programmer. The additional board is supplied with socket for AVR microcontrollers in DIP28 package, 2x5 male connectors connected to the microcontroller pins, pads, screw terminal for power supply, USB connector and reset button.

### Key features:

- Data transfer via USB-UART communication;
- Programming via the external programmer;
- Pads;
- 8 to 16V AC/DC power supply voltage;

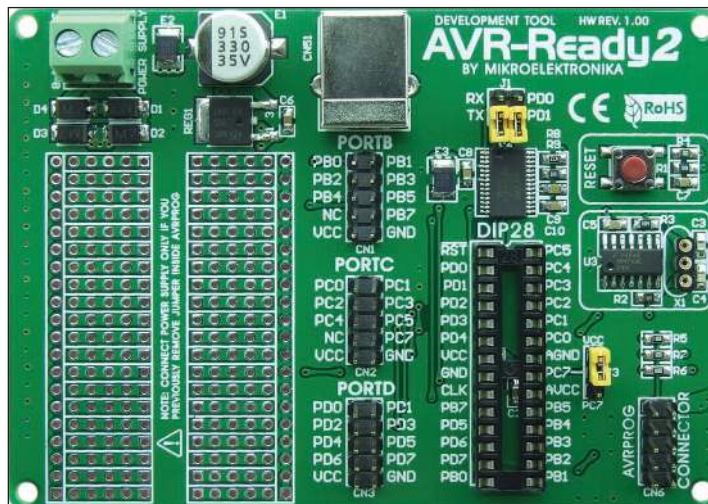

Figure 1: AVR-Ready2 additional board

### How to connect the board?

The AVR-Ready2 board features three 2x5 connectors (CN1 - CN3) that enable connection between the pins of the microcontroller plugged into the appropriate socket on the board and external devices. A 2x5 connector CN6 is used to connect the **AVRprog** programmer to the microcontroller pins used for programming. A USB connector CN51 enables connection between the additional board and a PC via the UART module. In order to enable USB-UART communication, it is necessary to place jumpers J1 and J2. By doing this, the RX and TX pins of the USB-UART module are connected to the appropriate pins of the microcontroller. In order to select function of pin PC7 (AREF) on the MCU you can use jumper J3. When jumper J3 is in the VCC position the PC7 pin will be supplied with power supply voltage and will be used as a voltage reference pin AREF. Jumper J3 in the PC7 position will enable the PC7 pin to be used as I/O. The additional board is powered with voltage in a range between 8 and 16V AC/DC via the CN8 connector.

### How to use the board?

In order to use the AVR-Ready2 additional board, it is first necessary to place a microcontroller in DIP28 package into the appropriate socket supplied on the board. The microcontroller is programmed with the AVRprog programmer that is plugged via its IDC10 connector into a 2x5 connector CN6 supplied on the board. In order to reset the microcontroller, just press the RESET button.

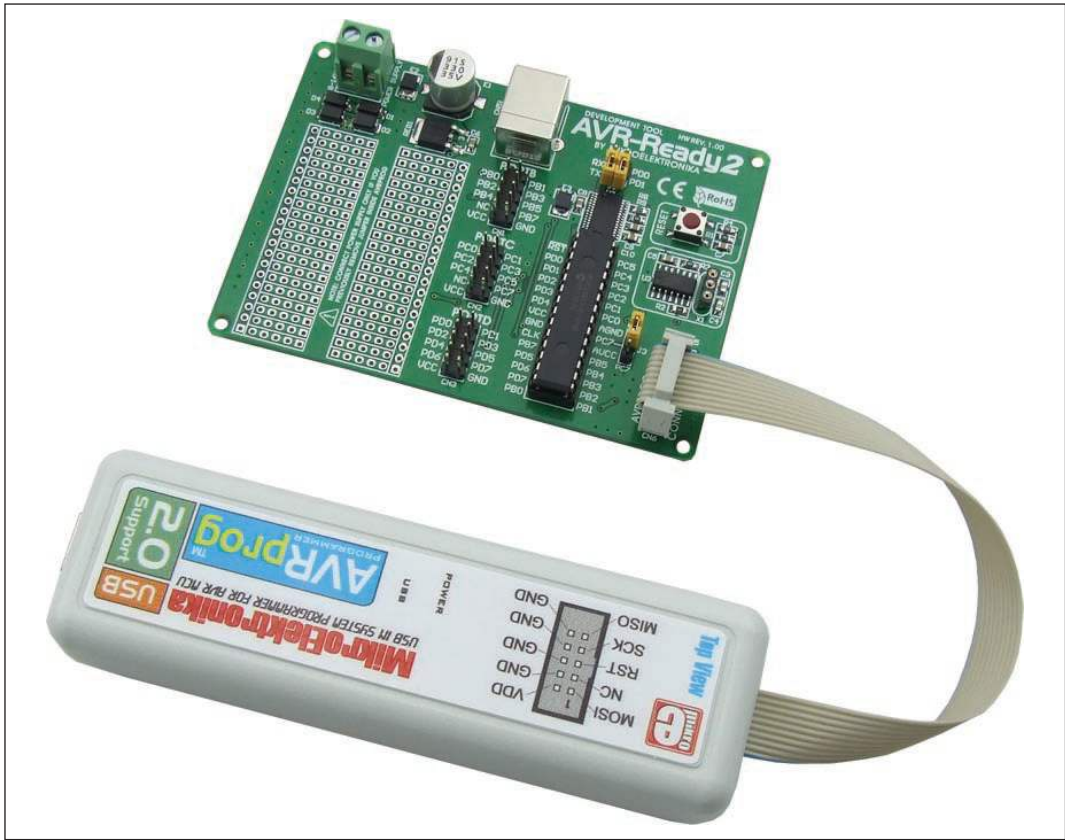

Figure 2: AVR-Ready2 additional board connected to the AVRprog programmer

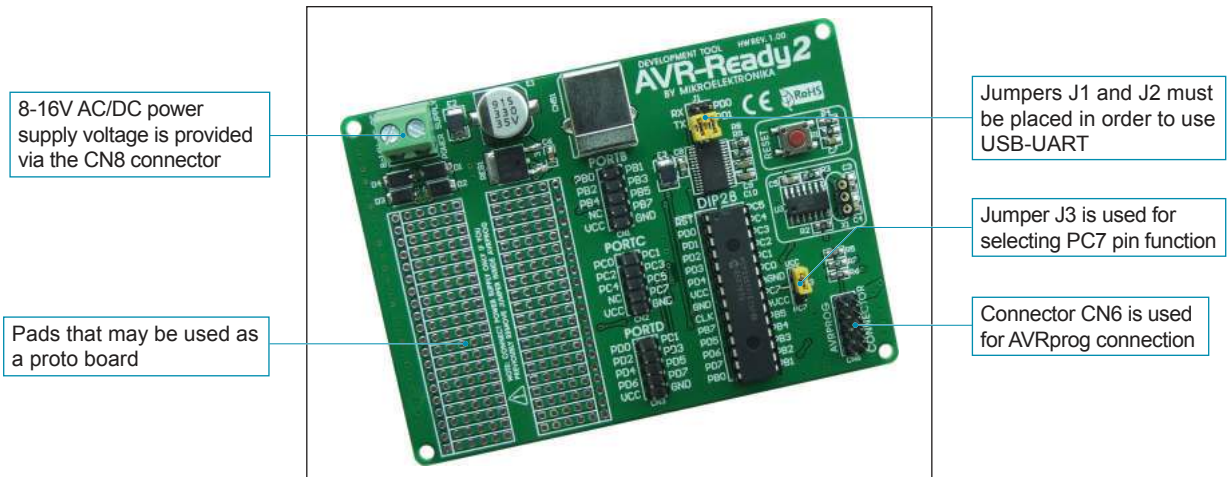

Figure 3: AVR-Ready2 with MCU

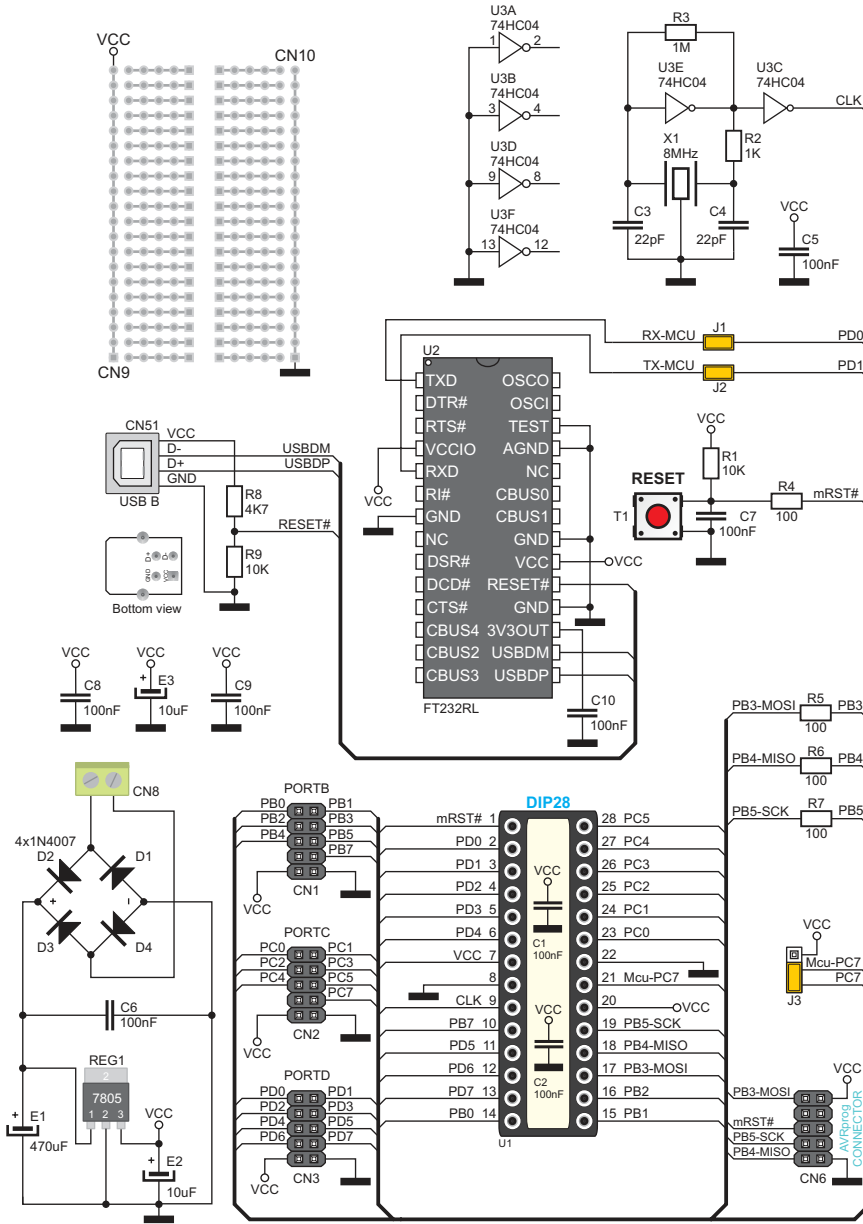

Figure 4: Additional board connection schematics

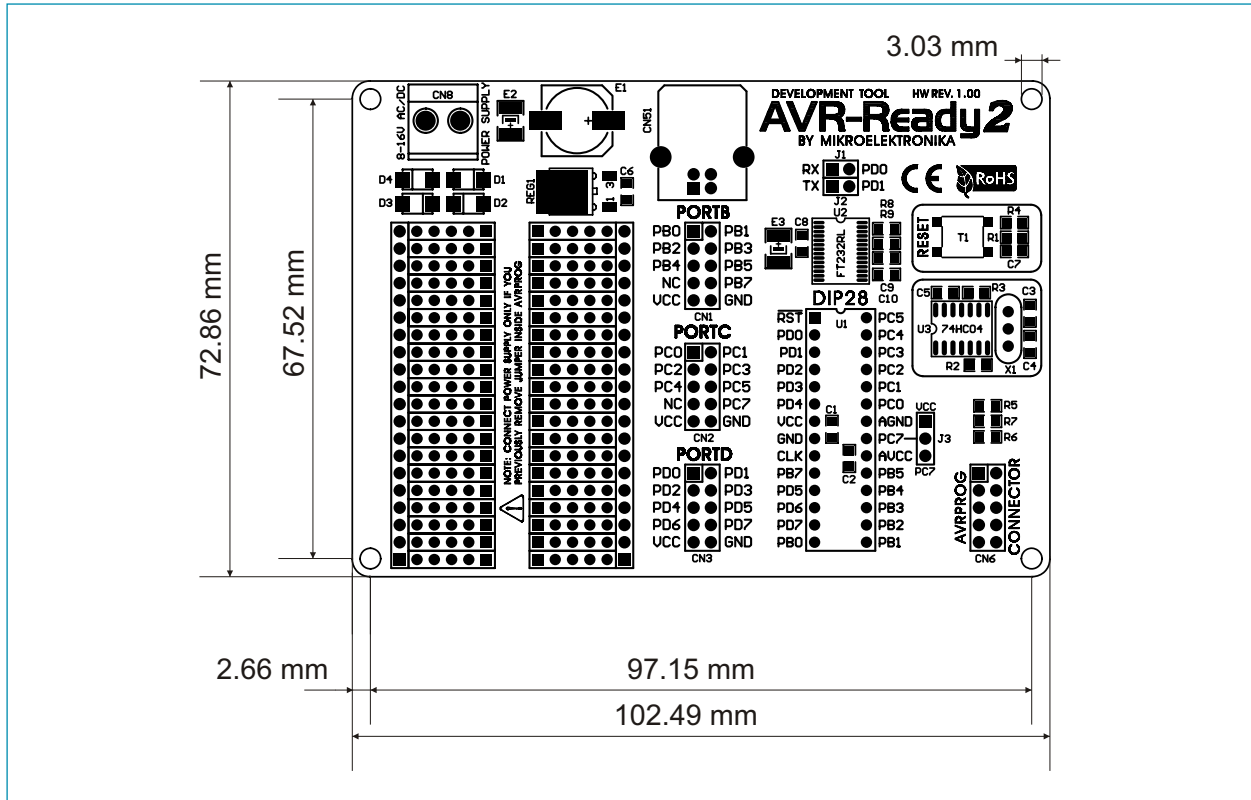

Figure 5: Additional board dimensions



**MikroElektronika**

SOFTWARE AND HARDWARE SOLUTIONS FOR EMBEDDED WORLD ...making it simple

If you want to learn more about our products, please visit our website at [www.mikroe.com](http://www.mikroe.com)

If you are experiencing some problems with any of our products or just need additional information, please place your ticket at [www.mikroe.com/en/support](http://www.mikroe.com/en/support)

If you have any questions, comments or business proposals, do not hesitate to contact us at [office@mikroe.com](mailto:office@mikroe.com)