

Evaluation Board for the **ADF4155** PLL Frequency Synthesizer

FEATURES

Self-contained board, including **ADF4155** synthesizer, differential 122.88 MHz temperature controlled crystal oscillator (TCXO), voltage controlled oscillator (VCO) 5.725 GHz to 5.875 GHz, loop filter, USB interface, and voltage regulators

Designed for a 61.44 MHz phase frequency detector (PFD) frequency, 0.9 mA charge pump current (I_{CP}), and 80 kHz loop bandwidth

Accompanying software allows complete control of synthesizer functions from a PC

Externally powered by 5.5 V

EVALUATION KIT CONTENTS

EV-ADF4155EB1Z board
CD with evaluation software
USB cable

REQUIRED ADDITIONAL EQUIPMENT

Windows[®]-based PC with USB port for evaluation software
Power supply (5.5 V)
Spectrum analyzer
50 Ω terminators

DOCUMENTS NEEDED

ADF4155 data sheet
EV-ADF4155EB1Z user guide
UG-476 user guide

REQUIRED SOFTWARE

Analog Devices **ADF4155** software, Version 1.0.0 or higher (included on the CD in the evaluation board kit or available for download at www.analog.com)

GENERAL DESCRIPTION

The **EV-ADF4155EB1Z** board evaluates the performance of the **ADF4155** frequency synthesizer for phase-locked loops (PLLs). A photograph of the evaluation board is shown in Figure 1. The evaluation board contains the **ADF4155** synthesizer, the loop filter, a VCO, a differential 122.88 MHz reference TCXO, a USB interface, power supply connectors, and SMA connectors. A USB cable is included to connect the board to a PC USB port.

In addition, the evaluation kit contains Windows-based software to allow easy programming of the synthesizer.

EVALUATION BOARD PHOTOGRAPH

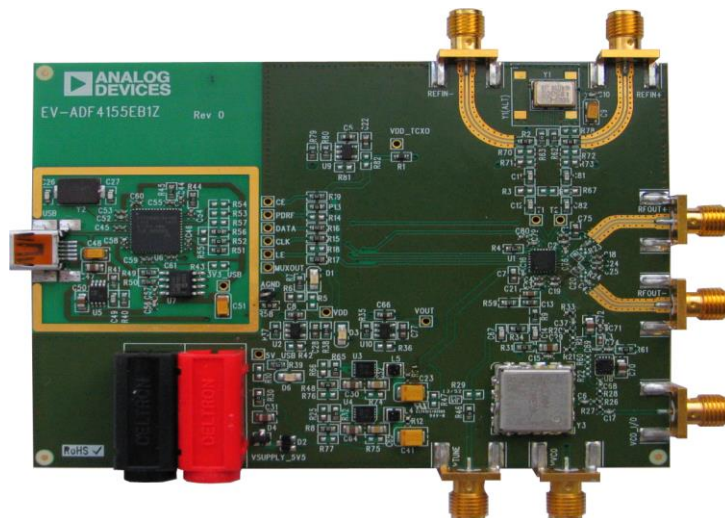

Figure 1. **EV-ADF4155EB1Z**

TABLE OF CONTENTS

Features	1	Evaluation Board Hardware.....	4
Evaluation Kit Contents.....	1	Power Supplies.....	4
Required Additional Equipment	1	Local Oscillator.....	4
Documents Needed.....	1	Output Signals	4
Required Software	1	Default Operation Settings	4
General Description	1	Evaluation Board Software.....	5
Evaluation Board Photograph.....	1	Main Controls.....	5
Revision History	2	Evaluation and Test	6
Getting Started.....	3	Evaluation Board Schematics and Artwork.....	8
Software Instalation Procedures.....	3	Bill of Materials.....	13
Evaluation Board Setup Procedures.....	3	Related Links.....	17

REVISION HISTORY

6/14—Revision 0: Initial Version

GETTING STARTED

SOFTWARE INSTALATION PROCEDURES

To install the software, see the [UG-476](#) user guide. The CD in the evaluation board kit contains the control software for the [EV-ADF4155EB1Z](#).

EVALUATION BOARD SETUP PROCEDURES

To run the software,

1. Click the [ADF4155](#) file on the desktop or from the **Start** menu.
2. On the **Select Device and Connection** tab, choose [ADF4155](#) and **USB board (green)**, and then click **Connect** (see Figure 2).

3. Confirm that **Analog Devices RFG.L Eval Board connected** is displayed at the bottom left of the window. Note that when connecting the board; allow 5 sec to 10 sec for the status label to change.
4. Under the **File** menu, the current settings can be saved to and loaded from a text file.

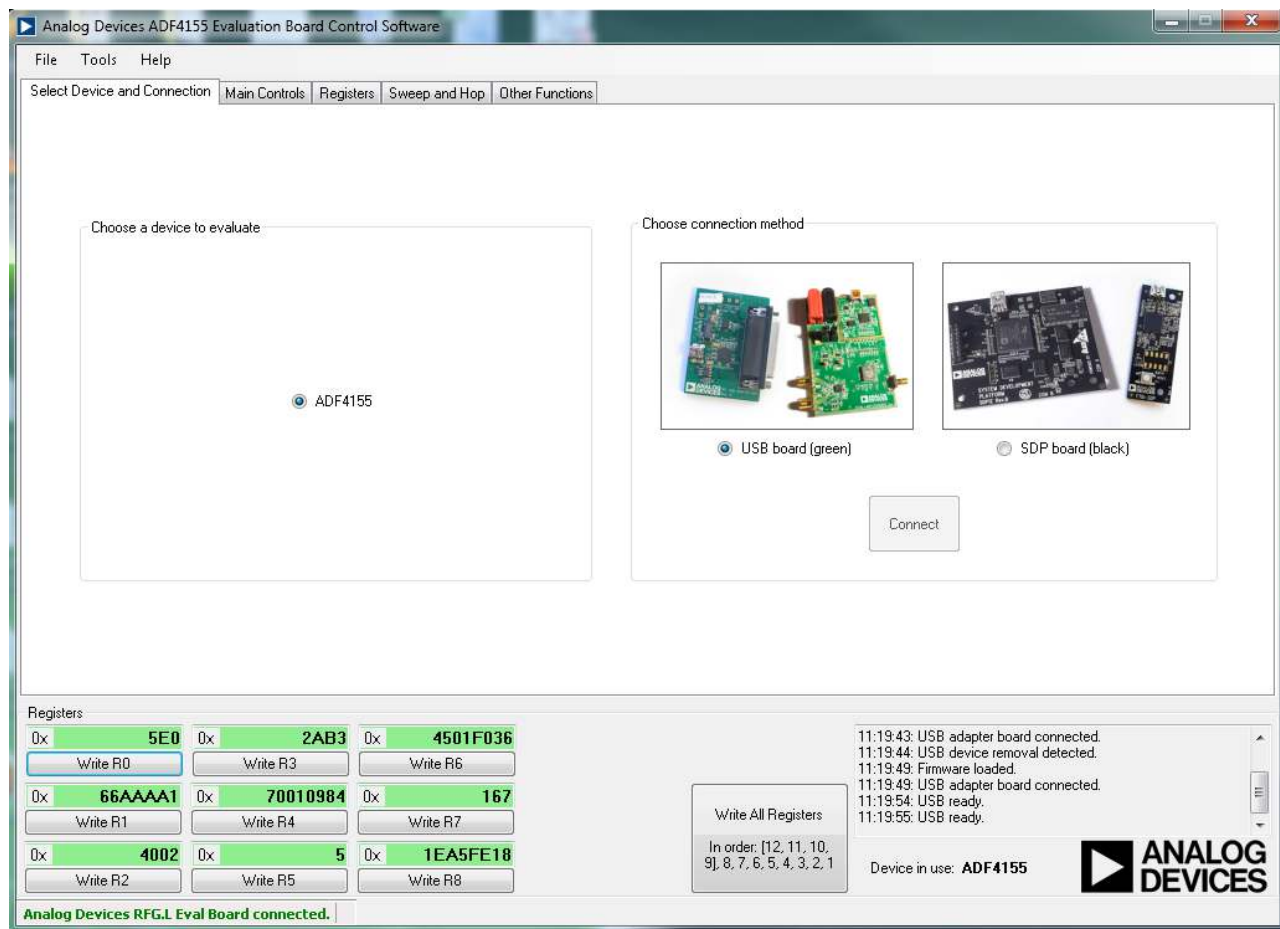

Figure 2. Software Front Panel Display—Select Device and Connection

EVALUATION BOARD HARDWARE

The [EV-ADF4155EB1Z](#) schematics are shown in Figure 7, Figure 8, Figure 9, and Figure 10. The silkscreen for the evaluation board is shown in Figure 11 and Figure 12.

POWER SUPPLIES

The board is powered by a 5.5 V power supply connected to the red and black banana connectors. Connect the red connector to a 5.5 V power supply and the black connector to ground.

The power supply circuit uses the [ADP151AUJZ-3.3](#) low noise, low dropout (LDO) linear regulators to provide the required 3.3 V supplies. The low noise, [ADP7104ACPZ-5.0-R7](#) regulators provide the required 5 V supplies.

The USB host powers the USB section of the evaluation board (see the area bounded by the gold box in Figure 1).

LOCAL OSCILLATOR

The 122.88 MHz TXCO provides the on chip differential reference frequency.

An external differential reference signal can be connected between REFIN+ and REFIN– edge mount connectors. Configure the board by removing R1, R62, R63, and inserting 0 Ω links in place of R2 and R68. To assure 50 Ω input impedance, populate R3 and R67 with 50 Ω resistors.

To use a single-ended TCXO, configure the board by replacing Y1, with Y1(ALT), remove R62, R63, C11 and insert 0 Ω links for R3 and R78.

A single-ended external signal generator can be connected to REFIN+ edge-mounted SMA connector. Configure the board by removing R1, R62, R63 and insert 0 Ω links in places of R3 and R68. To adjust impedance matching of the evaluation board to the external reference source, R67 can be populated with a 50 Ω resistor.

OUTPUT SIGNALS

The VCO output is available at the edge-mount SMA connector, VCO_I/O. The [ADF4155](#) differential RF_{OUT+} and RF_{OUT–} pins are available at the RFOUT+ and RFOUT– edge mount SMA connectors.

DEFAULT OPERATION SETTINGS

All components necessary for LO generation are inserted on the board. This board is shipped with the [ADF4155](#) synthesizer, a differential 122.88 MHz reference TCXO, a fourth-order 80 kHz loop filter ($I_{CP} = 0.9$ mA), and a VCO with a 5725 MHz to 5875 MHz frequency range.

EVALUATION BOARD SOFTWARE

The control software for the EVAL-ADF4151EB1Z accompanies the board on the CD included in the evaluation kit. To install the software, see the [UG-476](#) user guide.

MAIN CONTROLS

The **Main Controls** tab selects the RF and user configurable register settings. Consult the register description of the [ADF4155](#) data sheet for details.

In the **RF Settings** area, the **VCO RF Frequency** should equal the VCO frequency. The reference frequency should be the same as the applied reference signal. The PFD frequency is calculated from the reference frequency, the R-counter, the reference doubler, and the reference-divide-by-2. Ensure that the value in the **PFD Frequency** box matches the value specified in the loop filter design.

In the **Register 4** area, program the **Charge pump current** to the value for which the loop filter was designed.

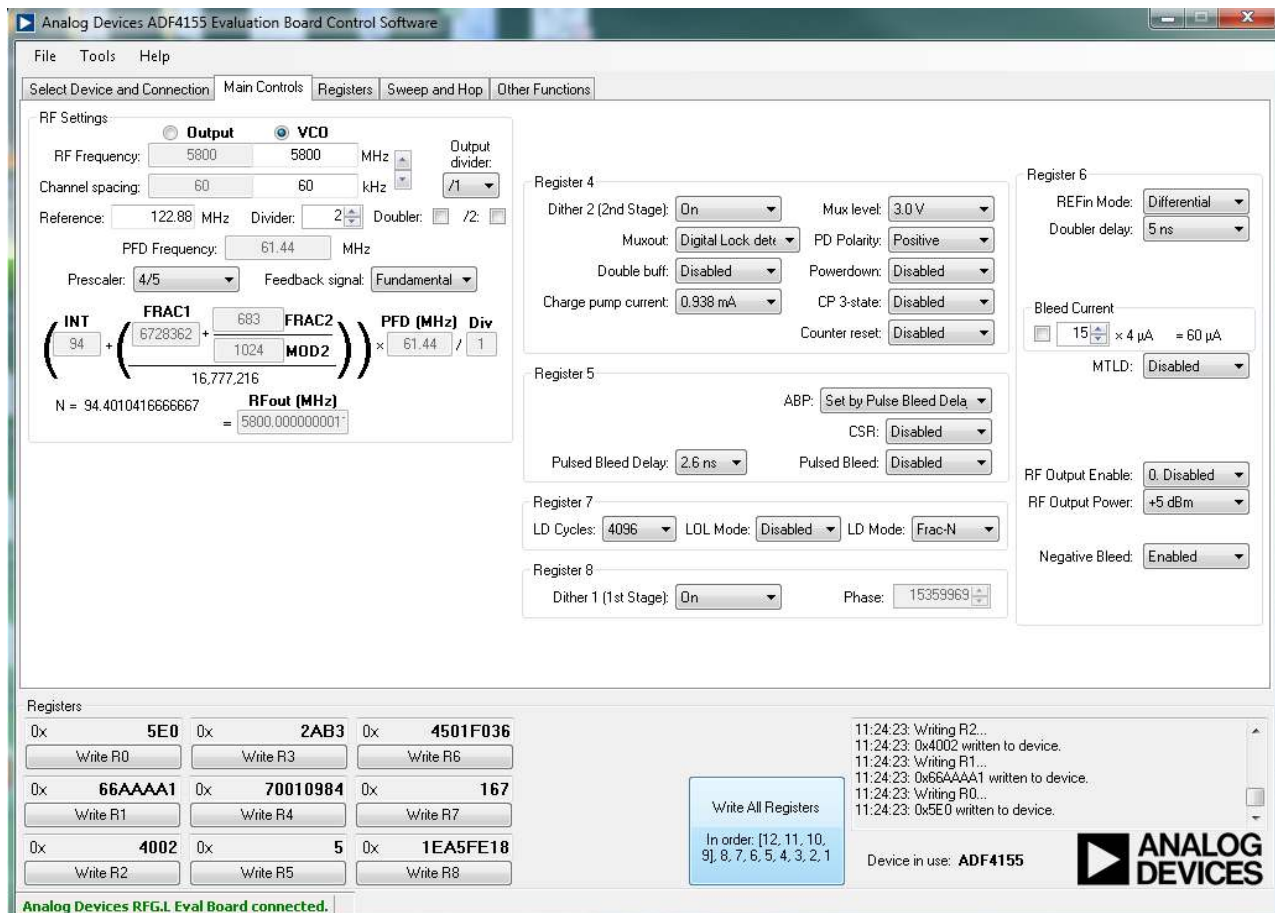

Figure 3. Software Front Panel Display—Main Controls

EVALUATION AND TEST

To evaluate and test the performance of the ADF4155, use the following procedure:

1. Install the ADF4155 software (see the UG-476 user guide).
2. Connect the EV-ADF4155EB1Z board to the PC.
3. Follow the hardware driver installation procedure (Windows XP only).
4. Connect 50 Ω terminators to RFOUT+ and RFOUT-.
5. Connect the power supply to the banana connectors (5.5 V).
6. Run the ADF4155 software.
7. Select **USB board (green)** and **ADF4155** in the **Select Device and Connection** tab of the software front panel display window.
8. Click the **Main Controls** tab. Click **Write All Registers**.
9. Connect the spectrum analyzer to the SMA connector VCO_I/O. Refer to Figure 6 for a typical evaluation setup.
10. Measure the output spectrum. Note that default settings are for a VCO frequency of 5.8 GHz.
11. Figure 4 shows a phase noise plot of the SMA VCO_I/O, VCO_{OUT} = 5800 MHz.
12. Figure 5 shows a phase noise plot of the SMA RFOUT+, RFOUT+/RFOUT- = 2900 MHz. To configure the EV-ADF4155EB1Z for this plot, use the following steps:
 - Set the output divider in the RF settings to 2.
 - Enable the RF output in Register 6.
 - Remove the 50 Ω terminators from SMA RFOUT+ and connect to SMA VCO_I/O.

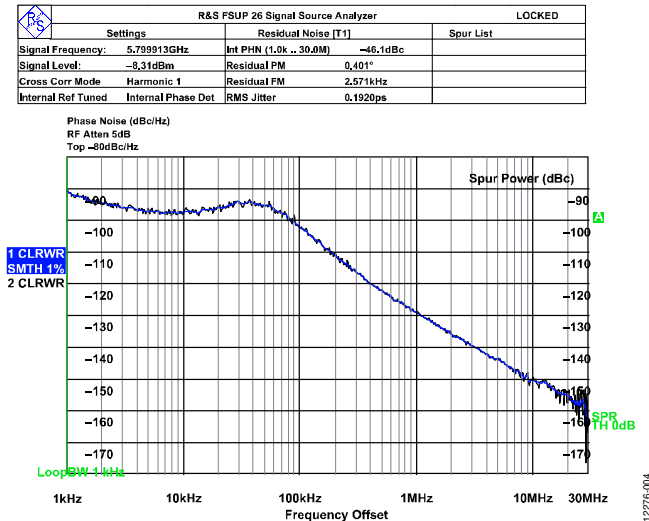

Figure 4. Fractional-N Phase Noise and Spur Performance, VCO_I/O, VCO_{OUT} = 5800 MHz

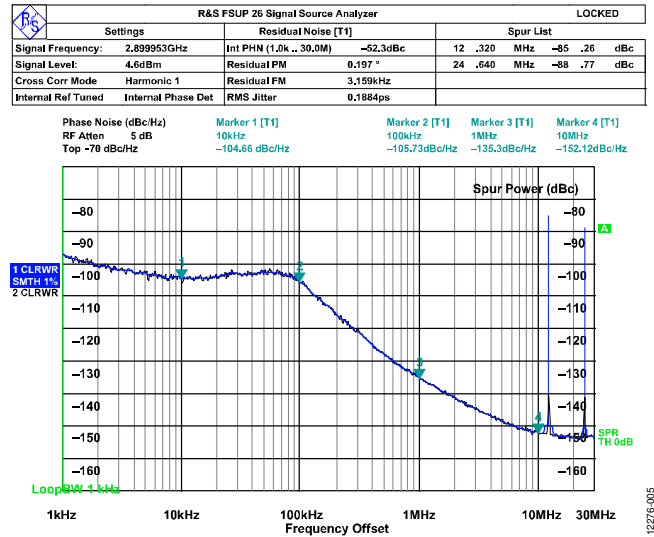

Figure 5. RFOUT+ Phase Noise, RF Divider = Two Enabled, Fractional-N, RFOUT+/RFOUT- = 2900 MHz, (Integer Boundary Spur at 12.32 MHz and the Second Harmonic Integer Boundary Spur 26.64 MHz Visible)

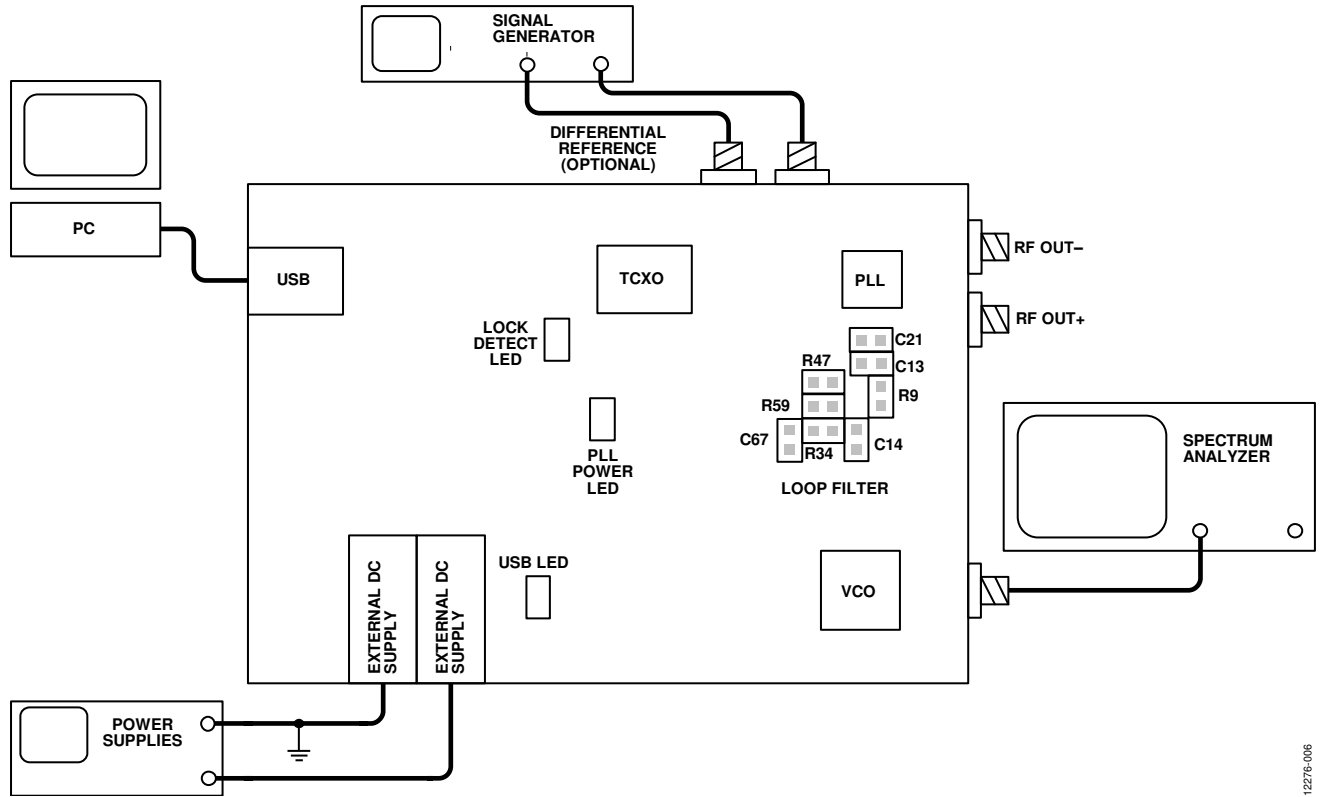

Figure 6. Typical Evaluation Setup

12275-006

EVALUATION BOARD SCHEMATICS AND ARTWORK

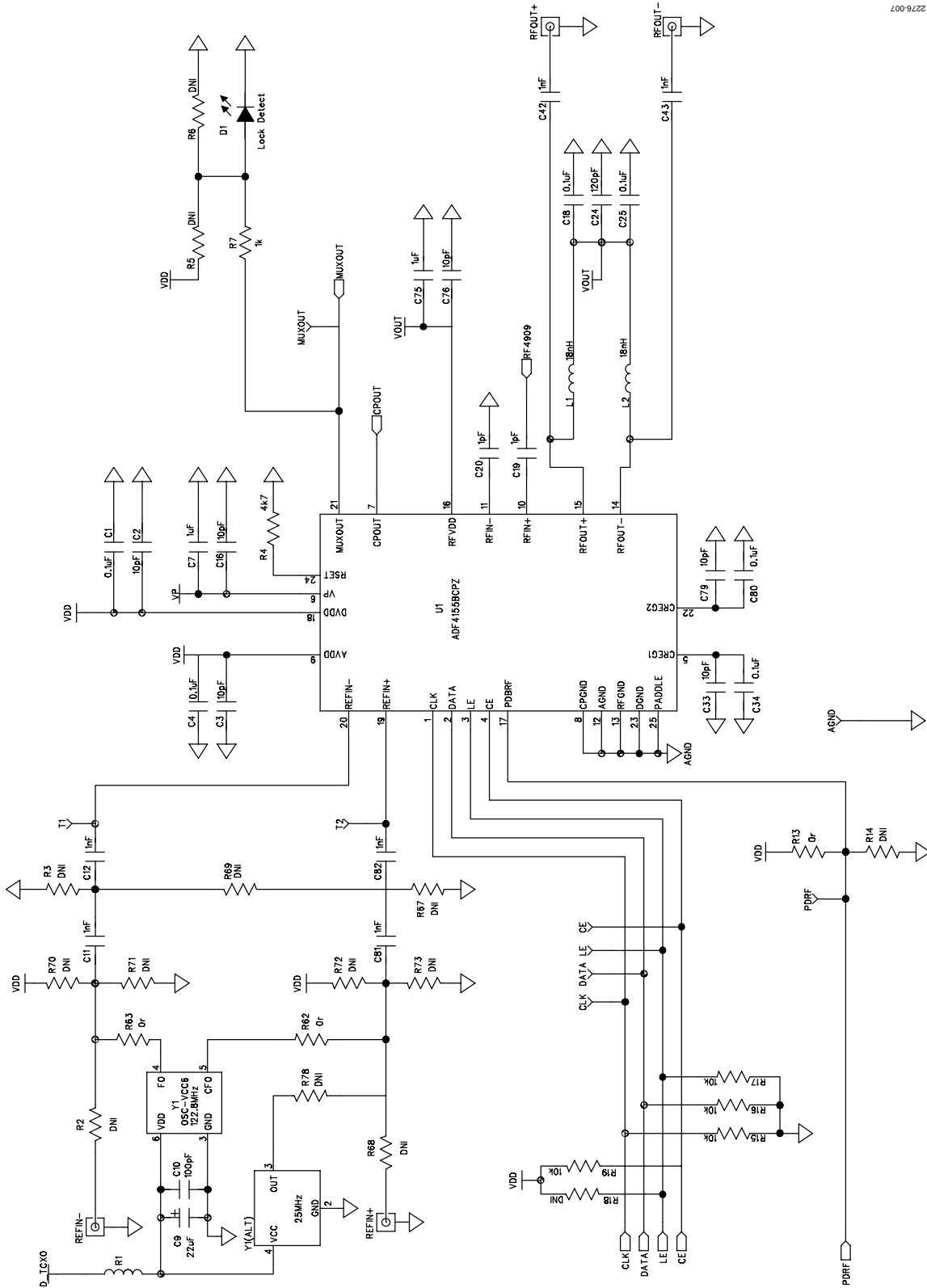

Figure 7. Evaluation Board Schematic (Page 1)

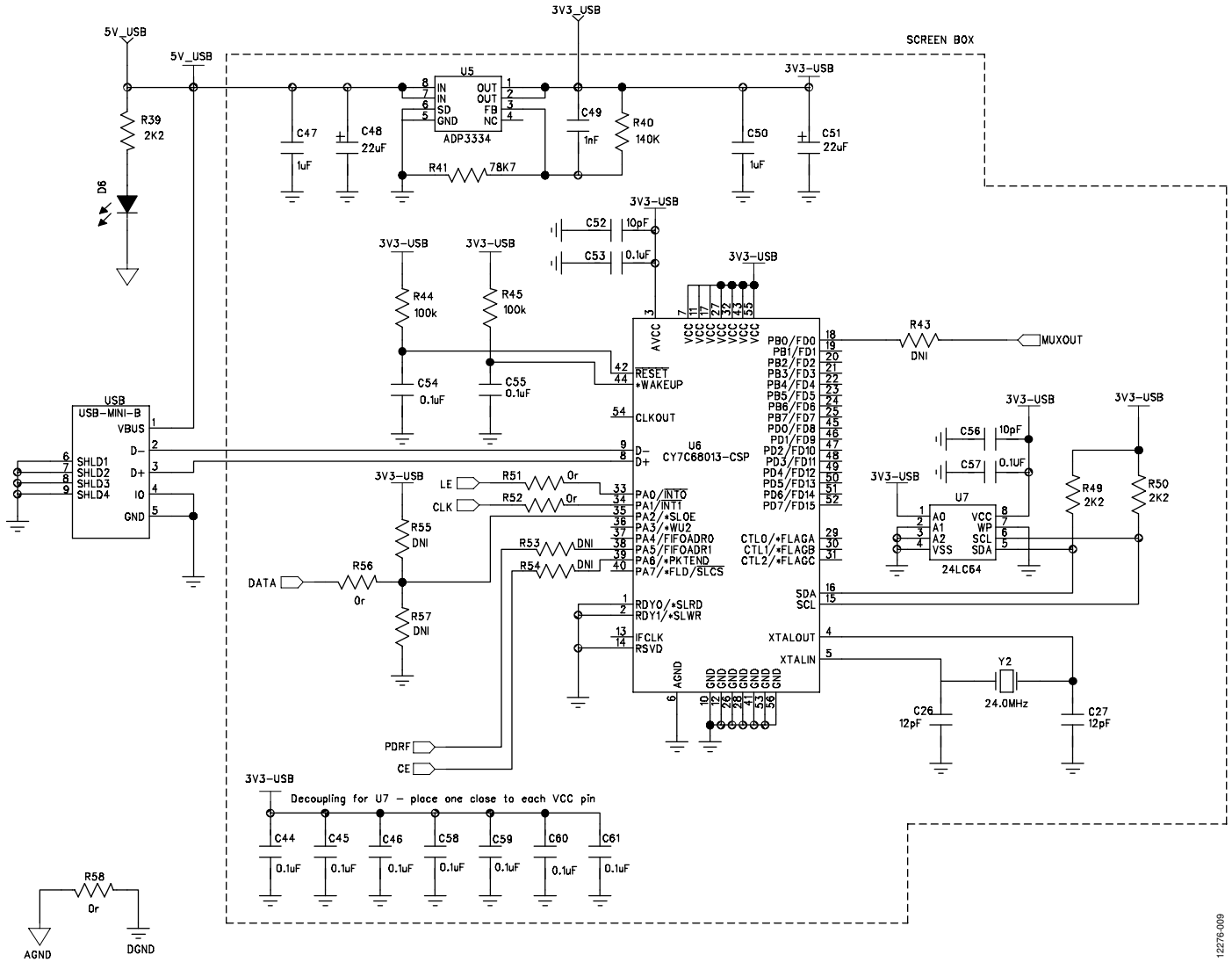

Figure 9. Evaluation Board Schematic (Page 3)

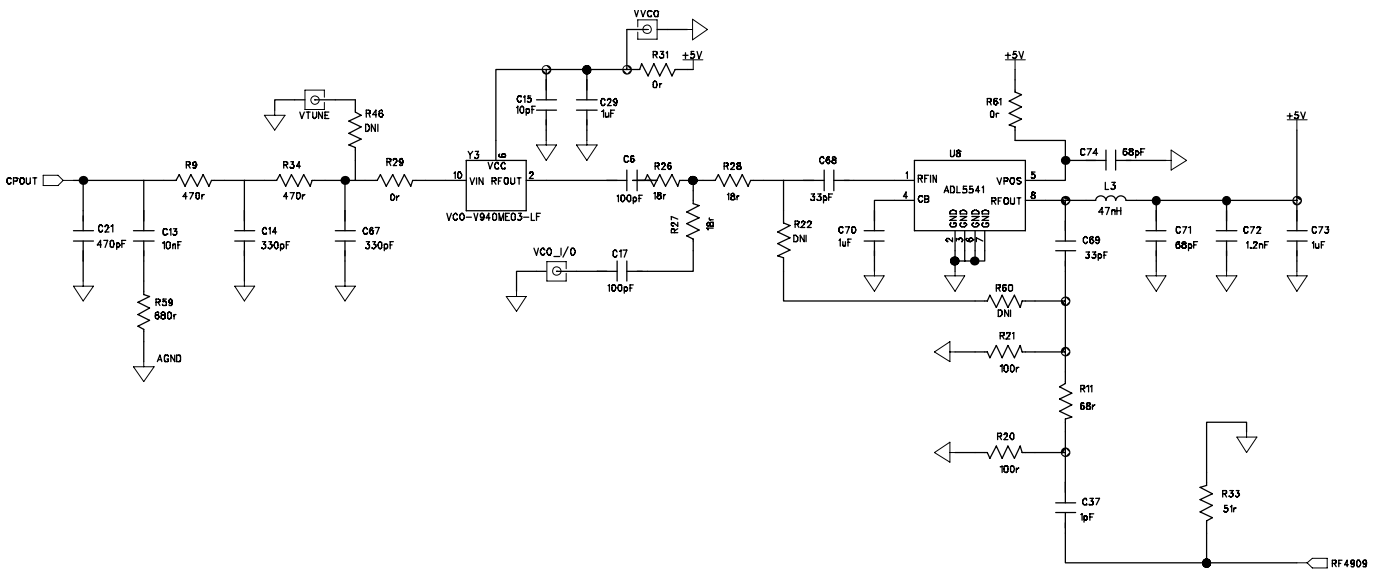

Figure 10. Evaluation Board Schematic (Page 4)

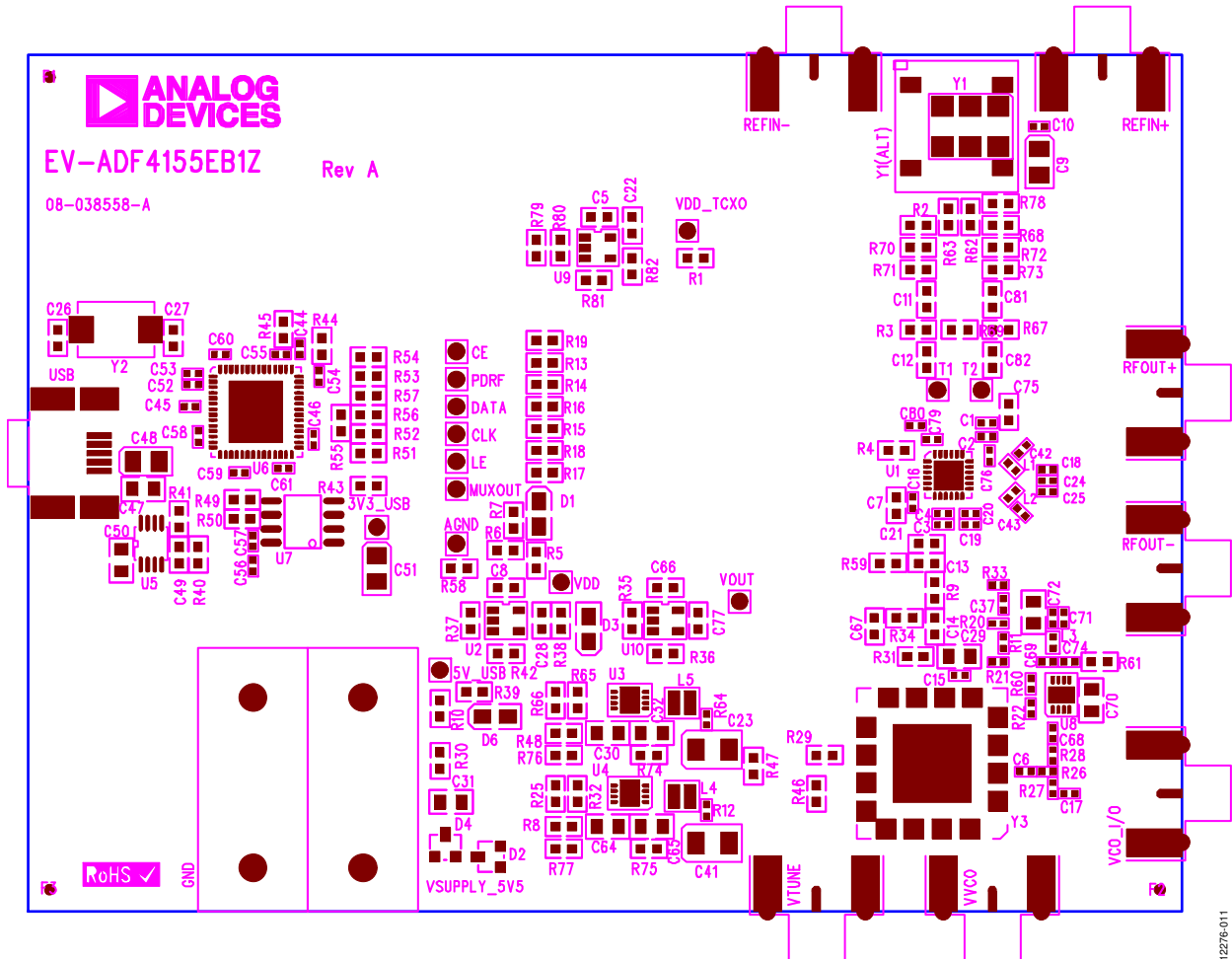

Figure 11. Evaluation Board Silkscreen (Top Side)

12276-011

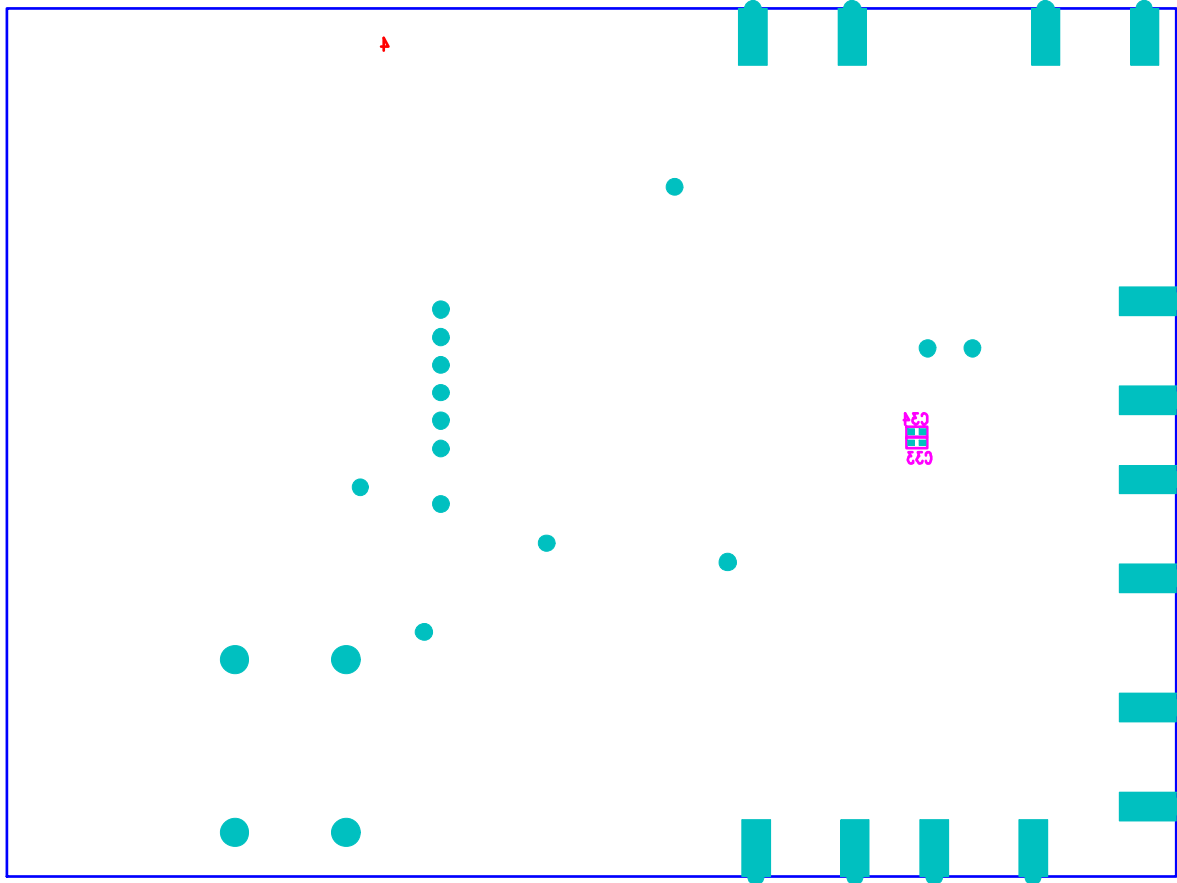

Figure 12. Evaluation Board Silkscreen (Bottom Side)

12276-012

BILL OF MATERIALS

Table 1.

Reference Designator	Value	Part Description	Manufacturer/Part Number
3V3_USB		Red testpoint	Vero 20-313137
5V_USB		Red testpoint	Vero 20-313137
AGND		Black testpoint	Vero 20-2137
C1	0.1 μ F	C0402 16 V, X7R ceramic capacitor	Kemet C0402C104K4RAC
C2	10 pF	C0402 50 V NP0 ceramic capacitor	AVX 04025U100GAT2A
C3	10 pF	C0402 50 V NP0 ceramic capacitor	AVX 04025U100GAT2A
C4	0.1 μ F	C0402 16 V, X7R ceramic capacitor	Kemet C0402C104K4RAC
C5	1 μ F	Capacitor, 0603 1 μ F 10 V X5R	Murata GRM188R61A105KA61D
C6	100 pF	C0402 50 V COG ceramic capacitor	Murata GRM1555C1H101JD01D
C7	1 μ F	Capacitor, 0603 1 μ F 10 V X5R	Murata GRM188R61A105KA61D
C8	1 μ F	Capacitor, 0603 1 μ F 10 V X5R	Murata GRM188R61A105KA61D
C9	22 μ F	TAJ_A capacitor, tantalum, 22 μ F, 6.3 V, A	AVX TAJA226K006RNJ
C10	100 pF	C0402 50 V COG ceramic capacitor	Murata GRM1555C1H101JD01D
C11	1 nF	C0603 50 V NP0 ceramic capacitor	AVX 06035A102JAT2A
C12	1 nF	C0603 50 V NP0 ceramic capacitor	AVX 06035A102JAT2A
C13	10 nF	Capacitor, NP0, 0603, 25 V, 10000 pF	Kemet C0603C103J3GACTU
C14	330 pF	Capacitor, NP0, 0603, 100 V, 330 pF	Kemet C0603C331J1GACTU
C15	10 pF	C0402 50 V NP0 ceramic capacitor	AVX 04025U100GAT2A
C16	10 pF	C0402 50 V NP0 ceramic capacitor	AVX 04025U100GAT2A
C17	100 pF	C0402 50 V COG ceramic capacitor	Murata GRM1555C1H101JD01D
C18	0.1 μ F	C0402 16 V, X7R ceramic capacitor	Kemet C0402C104K4RAC
C19	1 pF	C0402 50 V COG ceramic capacitor	AVX 04025A1R0BAT2A
C20	1 pF	C0402 50 V COG ceramic capacitor	AVX 04025A1R0BAT2A
C21	470 pF	Capacitor, NP0, 0603, 100 V, 470 PF	Kemet C0603C471J1GACTU
C22	1 μ F	C0603 capacitor, 0603 1 μ F 10 V X5R	Murata GRM188R61A105KA61D
C23	100 μ F	RTAJ_B capacitor, Case B, 100 μ F, 6 V	Kemet T520B107M006ATE040
C24	120 pF	C0402 50 V NP0 ceramic capacitor	AVX 04025A121JAT2A
C25	0.1 μ F	C0402 16 V, X7R ceramic capacitor	Kemet C0402C104K4RAC
C26	12 pF	C0603 50 V NPO SMD ceramic capacitor	Phycomp CC0603JRNPO9B1N20
C27	12 pF	C0603 50 V NPO SMD ceramic capacitor	Phycomp CC0603JRNPO9B1N20
C28	1 μ F	Capacitor, 0603 1 μ F 10 V X5R	Murata GRM188R61A105KA61D
C29	1 μ F	Ceramic capacitor 1 μ F 50 V 10% X5R 0805	Taiyo Yuden UMK212BJ105KG-T
C30	1 μ F	Ceramic capacitor 1 μ F 50 V 10% X5R 0805	Taiyo Yuden UMK212BJ105KG-T
C31	1 μ F	Ceramic capacitor 1 μ F 50 V 10% X5R 0805	Taiyo Yuden UMK212BJ105KG-T
C32	10 μ F	Ceramic capacitor 10 μ F 10 V 10% X5R 0805	Murata GRM21BR61A106KE19L
C33	10 pF	C0402 50 V NP0 ceramic capacitor	AVX 04025U100GAT2A
C34	0.1 μ F	C0402 16 V, X7R ceramic capacitor	Kemet C0402C104K4RAC
C37	1 pF	C0402 50 V COG ceramic capacitor	AVX 04025A1R0BAT2A
C41	100 μ F	RTAJ_B capacitor, case B, 100 μ F, 6 V	Kemet T520B107M006ATE040
C42	1 nF	Ceramic capacitor 1000 PF 50 V COG 0402	Murata GRM1555C1H102JA01D
C43	1 nF	Ceramic capacitor 1000 PF 50 V COG 0402	Murata GRM1555C1H102JA01D
C44	0.1 μ F	C0402 16 V, X7R ceramic capacitor	Kemet C0402C104K4RAC
C45	0.1 μ F	C0402 16 V, X7R ceramic capacitor	Kemet C0402C104K4RAC
C46	0.1 μ F	C0402 16 V, X7R ceramic capacitor	Kemet C0402C104K4RAC
C47	1 μ F	Ceramic capacitor 1 μ F 50 V 10% X5R 0805	Taiyo Yuden UMK212BJ105KG-T
C48	22 μ F	RTAJ_A 6.3 V tantalum capacitor (TAJ-A Case)	AVX TAJA226K006R
C49	1 nF	C0603 50 V NP0 ceramic capacitor	AVX 06035A102JAT2A
C50	1 μ F	Ceramic capacitor 1 μ F 50 V 10% X5R 0805	Taiyo Yuden UMK212BJ105KG-T
C51	22 μ F	RTAJ_A 6.3 V tantalum capacitor (TAJ-A Case)	AVX TAJA226K006R

Reference Designator	Value	Part Description	Manufacturer/Part Number
C52	10 pF	C0402 50 V NP0 ceramic capacitor	AVX 04025U100GAT2A
C53	0.1 μ F	C0402 16 V, X7R ceramic capacitor	Kemet C0402C104K4RAC
C54	0.1 μ F	C0402 16 V, X7R ceramic capacitor	Kemet C0402C104K4RAC
C55	0.1 μ F	C0402 16 V, X7R ceramic capacitor	Kemet C0402C104K4RAC
C56	10 pF	C0402 50 V NP0 ceramic capacitor	AVX 04025U100GAT2A
C57	0.1 μ F	C0402 16 V, X7R ceramic capacitor	Kemet C0402C104K4RAC
C58	0.1 μ F	C0402 16 V, X7R ceramic capacitor	Kemet C0402C104K4RAC
C59	0.1 μ F	C0402 16 V, X7R ceramic capacitor	Kemet C0402C104K4RAC
C60	0.1 μ F	C0402 16 V, X7R ceramic capacitor	Kemet C0402C104K4RAC
C61	0.1 μ F	C0402 16 V, X7R ceramic capacitor	Kemet C0402C104K4RAC
C64	1 μ F	Ceramic capacitor 1 μ F 50 V 10% X5R 0805	Taiyo Yuden UMK212BJ105KG-T
C65	10 μ F	Ceramic capacitor 10 μ F 10 V 10% X5R 0805	Murata GRM21BR61A106KE19L
C66	1 μ F	Capacitor, 0603 1 μ F 10 V X5R	Murata GRM188R61A105KA61D
C67	330 pF	Capacitor, NP0, 0603, 100 V, 330 PF	Kemet C0603C331J1GACTU
C68	33 pF	C0402 50 V COG ceramic capacitor	Kemet C0402C330J5GACTU
C69	33 pF	C0402 50 V COG ceramic capacitor	Kemet C0402C330J5GACTU
C70	1 μ F	Ceramic capacitor 1 μ F 50 V 10% X5R 0805	Taiyo Yuden UMK212BJ105KG-T
C71	68 pF	C0402 50 V COG ceramic capacitor	Kemet C0402C680J5GACTU
C72	1.2 nF	C0402 50 V COG ceramic capacitor	Kemet C0402C122K5RACTU
C73	1 μ F	Ceramic capacitor 1 μ F 50 V 10% X5R 0805	Taiyo Yuden UMK212BJ105KG-T
C74	68 pF	C0402 50 V COG ceramic capacitor	Kemet C0402C680J5GACTU
C75	1 μ F	Capacitor, 0603 1 μ F 10 V X5R	Murata GRM188R61A105KA61D
C76	10 pF	C0402 50 V NP0 ceramic capacitor	AVX 04025U100GAT2A
C77	1 μ F	Capacitor, 0603 1 μ F 10 V X5R	Murata GRM188R61A105KA61D
C79	10 pF	C0402 50 V NP0 ceramic capacitor	AVX 04025U100GAT2A
C80	0.1 μ F	C0402 16 V, X7R ceramic capacitor	Kemet C0402C104K4RAC
C81	1 nF	C0603 50 V NP0 ceramic capacitor	AVX 06035A102JAT2A
C82	1 nF	C0603 50 V NP0 ceramic capacitor	AVX 06035A102JAT2A
CE		Red testpoint	Vero 20-313137
CLK		Red testpoint	Vero 20-313137
D1		LED-0805 green LED	Avago Technologies HSMG-C170
D2	7.5 V	SOT23 Zener diode, 7.5 V, 300 MW	Fairchild BZX84C7V5
D3		0805 red LED	Avago Technologies HSMS-C170
D4		SOT23 diode, SCKY RECTI, 0.75 A, 40 V, SOT23	Diodes Inc. BAT750-7-F
D6		LED-0805 green LED	Avago Technologies HSMG-C170
DATA		Red testpoint	Vero 20-313137
GND		Black 4 mm banana socket	Deltron 571-0100-01
L1	18 nH	0402CS SMD inductor	Coilcraft 0403HQ-18NXJLU
L2	18 nH	0402CS SMD inductor	Coilcraft 0403HQ-18NXJLU
L3	47 nH	0402CS SMD inductor	Coilcraft 0402CS-47NX LU
L4	4.7 μ H	IND-EPL2014 inductor, SMT power EPL2014 series	Coilcraft EPL2014-472ML
L5	4.7 μ H	IND-EPL2014 inductor, SMT power EPL2014 series	Coilcraft EPL2014-472ML
LE		Red testpoint	Vero 20-313137
MUXOUT		Red testpoint	Vero 20-313137
PDRF		Red testpoint	Vero 20-313137
R1	470 Ω @ 100 MHz	L0603 ferrite bead	Wuerth Elektronik 7427-92642
R2	DNI	0603 resistor location—not inserted	Not applicable
R3	DNI	0603 resistor location—not inserted	Not applicable
R4	4.7 k Ω	R0603 SMD resistor	Multicomp MC0063W060314K7
R5	DNI	0603 resistor location—not inserted	Not applicable
R6	DNI	0603 resistor location—not inserted	Not applicable
R7	1 k Ω	R0603 SMD resistor	Multicomp MC 0.063W 0603 1K

Reference Designator	Value	Part Description	Manufacturer/Part Number
R8	0 Ω	R0603 SMD resistor	Multicomp MC 0.063W 0603 0R
R9	470 Ω	Resistor, 0603, 470 Ω	Multicomp MC0063W06031470R
R10	DNI	0603 resistor location—not inserted	Not applicable
R11	68 Ω	0402 SMD resistor	Multicomp MC00625W0402168R
R12	0.33 Ω	RESISTOR, 0.33 Ω 1% 0402	Welwyn LRCS0402-0R33FT5
R13	0 Ω	R0603 SMD resistor	Multicomp MC 0.063W 0603 0R
R14	DNI	0603 resistor location—not inserted	Not applicable
R15	10 k Ω	R0603 SMD resistor	Multicomp MC 0.063W 0603 10K
R16	10 k Ω	R0603 SMD resistor	Multicomp MC 0.063W 0603 10K
R17	10 k Ω	R0603 SMD resistor	Multicomp MC 0.063W 0603 10K
R18	DNI	0603 resistor location—not inserted	Not applicable Not applicable
R19	10 k Ω	R0603 SMD resistor	Multicomp MC 0.063W 0603 10K
R20	100 Ω	0402 SMD resistor	Multicomp MC 0.0625W 0402 1% 100R
R21	100 Ω	0402 SMD resistor	Multicomp MC 0.0625W 0402 1% 100R
R22	DNI	Resistor, 0402, 0 Ω , 0.1 W	Panasonic ERJ2GE0R00X
R23	DNI	R0402 SMD resistor	Multicomp MC 0.063W 0402 51R
R24	DNI	R0402 SMD resistor	Multicomp MC 0.063W 0402 51R
R25	DNI	0603 resistor location—not inserted	Not applicable
R26	18 Ω	0402 SMD resistor	Multicomp MC 0.0625W 0402 1% 18R
R27	18 Ω	0402 SMD resistor	Multicomp MC 0.0625W 0402 1% 18R
R28	18 Ω	0402 SMD resistor	Multicomp MC 0.0625W 0402 1% 18R
R29	0 Ω	R0603 SMD resistor	Multicomp MC 0.063W 0603 0R
R30	0 Ω	R0603 SMD resistor	Multicomp MC 0.063W 0603 0R
R31	0 Ω	R0603 SMD resistor	Multicomp MC 0.063W 0603 0R
R32	0 Ω	R0603 SMD resistor	Multicomp MC 0.063W 0603 0R
R33	51 Ω	0402 SMD resistor	Multicomp MC 0.063W 0402 51R
R34	470 Ω	Resistor, 0603, 470 Ω	Multicomp MC0063W06031470R
R35	0 Ω	R0603 SMD resistor	Multicomp MC 0.063W 0603 0R
R36	DNI	0603 resistor location—not inserted	Not applicable
R37	0 Ω	R0603 SMD resistor	Multicomp MC 0.063W 0603 0R
R38	1 k Ω	R0603 SMD resistor	Multicomp MC 0.063W 0603 1K
R39	2.2 k Ω	R0603 SMD resistor	Multicomp MC 0.063W 0603 2k2
R40	140 k Ω	R0603 SMD resistor	Multicomp MC 0.063W 0603 1% 140K
R41	78.7 k Ω	R0603 SMD resistor	Multicomp MC 0.063W 0603 1% 78K7
R42	DNI	0603 resistor location—not inserted	Not applicable
R43	DNI	0603 resistor location—not inserted	Not applicable
R44	100 k Ω	R0603 SMD resistor	Multicomp MC 0.063W 0603 100K
R45	100 k Ω	R0603 SMD resistor	Multicomp MC 0.063W 0603 100K
R46	DNI	0603 resistor location—not inserted	Not applicable
R47	DNI	0603 resistor location—not inserted	Not applicable
R48	0 Ω	R0603 SMD resistor	Multicomp MC 0.063W 0603 0R
R49	2.2 k Ω	R0603 SMD resistor	Multicomp MC 0.063W 0603 2k2
R50	2.2 k Ω	R0603 SMD resistor	Multicomp MC 0.063W 0603 2k2
R51	0 Ω	R0603 SMD resistor	Multicomp MC 0.063W 0603 0R
R52	0 Ω	R0603 SMD resistor	Multicomp MC 0.063W 0603 0R
R53	DNI	0603 resistor location—not inserted	Not applicable
R54	DNI	0603 resistor location—not inserted	Not applicable
R55	DNI	0603 resistor location—not inserted	Not applicable
R56	0 Ω	R0603 SMD resistor	Multicomp MC 0.063W 0603 0R
R57	DNI	0603 resistor location—not inserted	Not applicable Not applicable
R58	0 Ω	R0603 SMD resistor	Multicomp MC 0.063W 0603 0R
R59	680 Ω	Resistor, 0603, 680 Ω	Multicomp MC0063W06031680R

Reference Designator	Value	Part Description	Manufacturer/Part Number
R60	DNI	R0402 resistor, 0402, 0 Ω , 0.1 W	Panasonic ERJ2GE0R00X
R61	0 Ω	R0603 SMD resistor	Multicomp MC 0.063W 0603 0R
R62	0 Ω	R0603 SMD resistor	Multicomp MC 0.063W 0603 0R
R63	0 Ω	R0603 SMD resistor	Multicomp MC 0.063W 0603 0R
R64	0.33 Ω	R0402 resistor, 0.33 Ω 1% 0402	Welwyn LRCS0402-0R33FT5
R65	0 Ω	R0603 SMD resistor	Multicomp MC 0.063W 0603 0R
R66	DNI	0603 resistor location—not inserted	Not applicable
R67	DNI	0603 resistor location—not inserted	Not applicable
R68	DNI	0603 resistor location—not inserted	Not applicable
R69	DNI	0603 resistor location—not inserted	Not applicable
R70	DNI	0603 resistor location—not inserted	Not applicable
R71	DNI	0603 resistor location—not inserted	Not applicable
R72	DNI	0603 resistor location—not inserted	Not applicable
R73	DNI	0603 resistor location—not inserted	Not applicable
R74	DNI	0603 resistor location—not inserted	Not applicable
R75	DNI	0603 resistor location—not inserted	Not applicable
R76	DNI	0603 resistor location—not inserted	Not applicable
R77	DNI	0603 resistor location—not inserted	Not applicable
R78	DNI	0603 resistor location—not inserted	Not applicable
R79	0 Ω	R0603 SMD resistor	Multicomp MC 0.063W 0603 0R
R80	0 Ω	R0603 SMD resistor	Multicomp MC 0.063W 0603 0R
R81	DNI	0603 resistor location—not inserted	Not applicable
R82	DNI	0603 resistor location—not inserted	Not applicable
REFIN+		SMA_CARD_EDGE_RF_VER2 CONN jack end launch PC GOLD SMA	Emerson 142-0701-851
REFIN-		SMA_CARD_EDGE_RF_VER2 CONN jack end launch PC GOLD SMA	Emerson 142-0701-851
RFOUT+		SMA_CARD_EDGE_RF_VER2 CONN jack end launch PC GOLD SMA	Emerson 142-0701-851
RFOUT-		SMA_CARD_EDGE_RF_VER2 CONN jack end launch PC GOLD SMA	Emerson 142-0701-851
T1		Red testpoint	Vero 20-313137
T2		Red testpoint	Vero 20-313137
U1		LFCSP-24-7 PLL	Analog Devices ADF4155BCPZ
U2	3.3 V	TSOT-5 linear regulator	Analog Devices ADP151AUJZ-3.3
U3		LFCSP-8-5 linear regulator ADJ, 20 V, 300 mA, ultralow noise, CMOS	Analog Devices ADP7104ACPZ-5.0
U4		LFCSP-8-5 linear regulator ADJ, 20 V, 300 mA, ultralow noise, CMOS	Analog Devices ADP7104ACPZ-5.0
U5		MSO8 adjustable LDO regulator	Analog Devices ADP3334ARMZ
U6		LFCSP-56_RP USB microcontroller	Cypress Semiconductor CY7C68013A-56LFXC
U7		SO8NB 64K I2C serial EEPROM	Microchip Technology 24LC64-ISN
U8		8-lead LFCSP 3 mm 50 MHz to 6 GHz RF/IF gain block	Analog Devices ADL5541ACPZ
U9	3.3 V	TSOT-5 linear regulator	Analog Devices ADP151AUJZ-3.3
U10	3.3 V	TSOT-5 linear regulator	Analog Devices ADP151AUJZ-3.3
USB		USB-MINI-B USB Mini-B connector (usb-otg)	Molex 54819-0578
VCO_I/O		SMA_CARD_EDGE_RF_VER2 CONN jack end launch PC GOLD SMA	Emerson 142-0701-851
VDD		Red testpoint	Vero 20-313137
VDD_TCXO		Red testpoint	Vero 20-313137
VOUT		Red testpoint	Vero 20-313137
VSUPPLY_5V5		Red 4 mm banana socket	Deltron 571-0500-01

Reference Designator	Value	Part Description	Manufacturer/Part Number
VTUNE		SMA_CARD_EDGE_RF_VER2 CONN jack end launch PC GOLD SMA	Emerson 142-0701-851
VWCO		SMA_CARD_EDGE_RF_VER2 CONN jack end launch PC GOLD SMA	Emerson 142-0701-851
Y1	122.8 MHz	OSC-VCC6 3.3 V LVDS crystal oscillator	Vectron International VCC6-LAB-122- LAB122M880000
Y1(ALT)	25 MHz	OSC_TCXO SMD temperature compensated crystal oscillator	Rakon TXO225B
Y2	24.0 MHz	XTAL-CSM-8ASMD crystal	ECS International ECS-240-12-20A-TR
Y3		VCO190-1750T VCO	Z-Communications, Inc. V940ME03

RELATED LINKS

Resource	Description
ADF4155	Product Page, Integer-N/Fractional-N PLL Synthesizer
ADP151	Product Page, Ultra Low Noise, 150 mA CMOS Linear Regulator
ADP7104	Product Page, 20 V, 500 mA, Low Noise, CMOS LDO
ADP3334	Product Page, High Accuracy Low I _o , 500 mA anyCAP® Adjustable Low Dropout Regulator
ADL5541	Product Page, 50 MHz to 6 GHz RF/IF Gain Block, Gain of 15 dB

NOTES

I²C refers to a communications protocol originally developed by Philips Semiconductors (now NXP Semiconductors).

**ESD Caution**

ESD (electrostatic discharge) sensitive device. Charged devices and circuit boards can discharge without detection. Although this product features patented or proprietary protection circuitry, damage may occur on devices subjected to high energy ESD. Therefore, proper ESD precautions should be taken to avoid performance degradation or loss of functionality.

Legal Terms and Conditions

By using the evaluation board discussed herein (together with any tools, components documentation or support materials, the "Evaluation Board"), you are agreeing to be bound by the terms and conditions set forth below ("Agreement") unless you have purchased the Evaluation Board, in which case the Analog Devices Standard Terms and Conditions of Sale shall govern. Do not use the Evaluation Board until you have read and agreed to the Agreement. Your use of the Evaluation Board shall signify your acceptance of the Agreement. This Agreement is made by and between you ("Customer") and Analog Devices, Inc. ("ADI"), with its principal place of business at One Technology Way, Norwood, MA 02062, USA. Subject to the terms and conditions of the Agreement, ADI hereby grants to Customer a free, limited, personal, temporary, non-exclusive, non-sublicensable, non-transferable license to use the Evaluation Board FOR EVALUATION PURPOSES ONLY. Customer understands and agrees that the Evaluation Board is provided for the sole and exclusive purpose referenced above, and agrees not to use the Evaluation Board for any other purpose. Furthermore, the license granted is expressly made subject to the following additional limitations: Customer shall not (i) rent, lease, display, sell, transfer, assign, sublicense, or distribute the Evaluation Board; and (ii) permit any Third Party to access the Evaluation Board. As used herein, the term "Third Party" includes any entity other than ADI, Customer, their employees, affiliates and in-house consultants. The Evaluation Board is NOT sold to Customer; all rights not expressly granted herein, including ownership of the Evaluation Board, are reserved by ADI. **CONFIDENTIALITY.** This Agreement and the Evaluation Board shall all be considered the confidential and proprietary information of ADI. Customer may not disclose or transfer any portion of the Evaluation Board to any other party for any reason. Upon discontinuation of use of the Evaluation Board or termination of this Agreement, Customer agrees to promptly return the Evaluation Board to ADI. **ADDITIONAL RESTRICTIONS.** Customer may not disassemble, decompile or reverse engineer chips on the Evaluation Board. Customer shall inform ADI of any occurred damages or any modifications or alterations it makes to the Evaluation Board, including but not limited to soldering or any other activity that affects the material content of the Evaluation Board. Modifications to the Evaluation Board must comply with applicable law, including but not limited to the RoHS Directive. **TERMINATION.** ADI may terminate this Agreement at any time upon giving written notice to Customer. Customer agrees to return to ADI the Evaluation Board at that time. **LIMITATION OF LIABILITY.** THE EVALUATION BOARD PROVIDED HEREUNDER IS PROVIDED "AS IS" AND ADI MAKES NO WARRANTIES OR REPRESENTATIONS OF ANY KIND WITH RESPECT TO IT. ADI SPECIFICALLY DISCLAIMS ANY REPRESENTATIONS, ENDORSEMENTS, GUARANTEES, OR WARRANTIES, EXPRESS OR IMPLIED, RELATED TO THE EVALUATION BOARD INCLUDING, BUT NOT LIMITED TO, THE IMPLIED WARRANTY OF MERCHANTABILITY, TITLE, FITNESS FOR A PARTICULAR PURPOSE OR NON-INFRINGEMENT OF INTELLECTUAL PROPERTY RIGHTS. IN NO EVENT WILL ADI AND ITS LICENSORS BE LIABLE FOR ANY INCIDENTAL, SPECIAL, INDIRECT, OR CONSEQUENTIAL DAMAGES RESULTING FROM CUSTOMER'S POSSESSION OR USE OF THE EVALUATION BOARD, INCLUDING BUT NOT LIMITED TO LOST PROFITS, DELAY COSTS, LABOR COSTS OR LOSS OF GOODWILL. ADI'S TOTAL LIABILITY FROM ANY AND ALL CAUSES SHALL BE LIMITED TO THE AMOUNT OF ONE HUNDRED US DOLLARS (\$100,000). **EXPORT.** Customer agrees that it will not directly or indirectly export the Evaluation Board to another country, and that it will comply with all applicable United States federal laws and regulations relating to exports. **GOVERNING LAW.** This Agreement shall be governed by and construed in accordance with the substantive laws of the Commonwealth of Massachusetts (excluding conflict of law rules). Any legal action regarding this Agreement will be heard in the state or federal courts having jurisdiction in Suffolk County, Massachusetts, and Customer hereby submits to the personal jurisdiction and venue of such courts. The United Nations Convention on Contracts for the International Sale of Goods shall not apply to this Agreement and is expressly disclaimed.