

BAS40 series; 1PSxxSB4x series

General-purpose Schottky diodes

Rev. 9 — 18 March 2015

Product data sheet

1. Product profile

1.1 General description

General-purpose Schottky diodes in small Surface-Mounted Device (SMD) plastic packages.

Table 1. Product overview

Type number	Package		Configuration
	NXP	JEITA	
1PS70SB40	SOT323	SC-70	single diode
1PS76SB40	SOD323	SC-76	single diode
1PS79SB40	SOD523	SC-79	single diode
BAS40	SOT23	-	single diode
BAS40H	SOD123F	-	single diode
BAS40L	SOD882	-	single diode
BAS40W	SOT323	SC-70	single diode
1PS70SB44	SOT323	SC-70	dual series
BAS40-04	SOT23	-	dual series
BAS40-04W	SOT323	SC-70	dual series
1PS70SB45	SOT323	SC-70	dual common cathode
1PS75SB45	SOT416	SC-75	dual common cathode
BAS40-05	SOT23	-	dual common cathode
BAS40-05W	SOT323	SC-70	dual common cathode
1PS70SB46	SOT323	SC-70	dual common anode
BAS40-06	SOT23	-	dual common anode
BAS40-06W	SOT323	SC-70	dual common anode
BAS40-07	SOT143B	-	dual isolated
BAS40-07V	SOT666	-	dual isolated
BAS40-05V	SOT666	-	quadruple common cathode/ common cathode
1PS88SB48	SOT363	SC-88	quadruple common cathode/ common cathode
BAS40XY	SOT363	SC-88	quadruple; 2 series



1.2 Features and benefits

- High switching speed
 - High breakdown voltage
 - AEC-Q101 qualified
- Low leakage current
 - Low capacitance

1.3 Applications

- Ultra high-speed switching
- Voltage clamping

1.4 Quick reference data

Table 2. Quick reference data

Symbol	Parameter	Conditions	Min	Typ	Max	Unit
Per diode						
I_F	forward current		-	-	120	mA
V_F	forward voltage	$I_F = 1 \text{ mA}$	[1]	-	380	mV
V_R	reverse voltage		-	-	40	V

[1] Pulse test: $t_p \leq 300 \mu\text{s}$; $\delta \leq 0.02$.

2. Pinning information

Table 3. Pinning





Pin	Description	Simplified outline	Symbol
BAS40H; 1PS76SB40; 1PS79SB40			
1	cathode [1]	 <p>001aab540</p>	 sym001
2	anode		
BAS40L			
1	cathode [1]	 <p>Transparent top view</p>	 sym001
2	anode		
BAS40; BAS40W; 1PS70SB40			
1	anode	 <p>006aaa144</p>	 006aaa436
2	not connected		
3	cathode		

Table 3. Pinning ...continued

Pin	Description	Simplified outline	Symbol
BAS40-04; BAS40-04W; 1PS70SB44			
1	anode (diode 1)	 <p>006aaa144</p>	 <p>006aaa437</p>
2	cathode (diode 2)		
3	cathode (diode 1), anode (diode 2)		
BAS40-05; BAS40-05W; 1PS70SB45; 1PS75SB45			
1	anode (diode 1)	 <p>006aaa144</p>	 <p>006aaa438</p>
2	anode (diode 2)		
3	cathode (diode 1), cathode (diode 2)		
BAS40-06; BAS40-06W; 1PS70SB46			
1	cathode (diode 1)	 <p>006aaa144</p>	 <p>006aaa439</p>
2	cathode (diode 2)		
3	anode (diode 1), anode (diode 2)		
BAS40-07			
1	cathode (diode 1)		 <p>006aaa434</p>
2	cathode (diode 2)		
3	anode (diode 2)		
4	anode (diode 1)		
BAS40-07V			
1	anode (diode 1)		 <p>006aaa440</p>
2	not connected		
3	cathode (diode 2)		
4	anode (diode 2)		
5	not connected		
6	cathode (diode 1)		

Table 3. Pinning ...continued

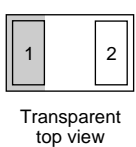
Pin	Description	Simplified outline	Symbol
BAS40-05V; 1PS88SB48			
1	anode (diode 1)	 <p>001aab555</p>	 <p>006aaa446</p>
2	anode (diode 2)		
3	cathode (diode 3), cathode (diode 4)		
4	anode (diode 3)		
5	anode (diode 4)		
6	cathode (diode 1), cathode (diode 2)		
BAS40XY			
1	anode (diode 1)		 <p>006aaa256</p>
2	cathode (diode 2)		
3	anode (diode 3), cathode (diode 4)		
4	anode (diode 4)		
5	cathode (diode 3)		
6	cathode (diode 1), anode (diode 2)		

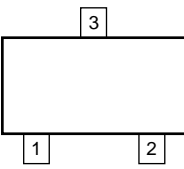
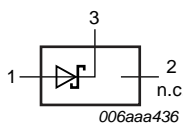
[1] The marking bar indicates the cathode.

3. Ordering information

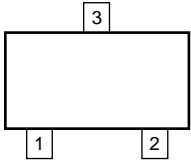
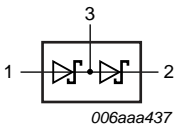
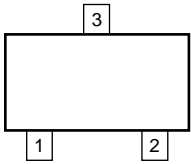
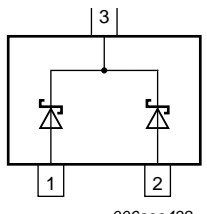
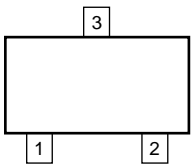
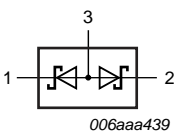
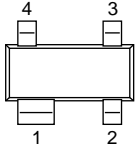
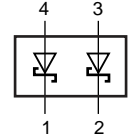
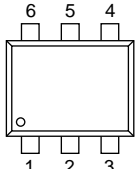
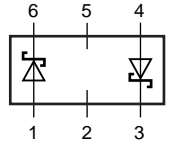
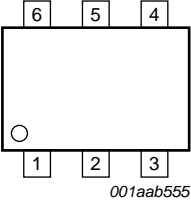
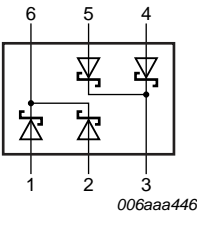
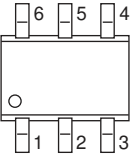
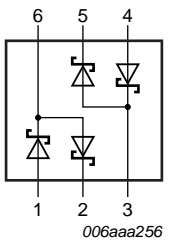
Table 4. Ordering information

Type number	Package		
	Name	Description	Version
1PS70SB40	SC-70	plastic surface-mounted package; 3 leads	SOT323
1PS76SB40	SC-76	plastic surface-mounted package; 2 leads	SOD323
1PS79SB40	SC-79	plastic surface-mounted package; 2 leads	SOD523
BAS40	-	plastic surface-mounted package; 3 leads	SOT23
BAS40H	-	plastic surface-mounted package; 2 leads	SOD123F
BAS40L	-	leadless ultra small plastic package; 2 terminals; body 1.0 × 0.6 × 0.5 mm	SOD882
BAS40W	SC-70	plastic surface-mounted package; 3 leads	SOT323
1PS70SB44	SC-70	plastic surface-mounted package; 3 leads	SOT323
BAS40-04	-	plastic surface-mounted package; 3 leads	SOT23
BAS40-04W	SC-70	plastic surface-mounted package; 3 leads	SOT323
1PS70SB45	SC-70	plastic surface-mounted package; 3 leads	SOT323
1PS75SB45	SC-75	plastic surface-mounted package; 3 leads	SOT416
BAS40-05	-	plastic surface-mounted package; 3 leads	SOT23
BAS40-05W	SC-70	plastic surface-mounted package; 3 leads	SOT323
1PS70SB46	SC-70	plastic surface-mounted package; 3 leads	SOT323
BAS40-06	-	plastic surface-mounted package; 3 leads	SOT23
BAS40-06W	SC-70	plastic surface-mounted package; 3 leads	SOT323
BAS40-07	-	plastic surface-mounted package; 4 leads	SOT143B
BAS40-07V	-	plastic surface-mounted package; 6 leads	SOT666
BAS40-05V	-	plastic surface-mounted package; 6 leads	SOT666
1PS88SB48	SC-88	plastic surface-mounted package; 6 leads	SOT363
BAS40XY	SC-88	plastic surface-mounted package; 6 leads	SOT363

4. Marking

Table 5. Marking codes

Type number	Marking code ^[1]	Type number	Marking code ^[1]
1PS70SB40	6*3	1PS75SB45	45
1PS76SB40	S4	BAS40-05	45*
1PS79SB40	T	BAS40-05W	65*
BAS40	43*	1PS70SB46	6*6
BAS40H	AJ	BAS40-06	46*
BAS40L	S6	BAS40-06W	66*
BAS40W	63*	BAS40-07	47*
1PS70SB44	6*4	BAS40-07V	67
BAS40-04	44*	BAS40-05V	65
BAS40-04W	64*	1PS88SB48	8*5
1PS70SB45	6*5	BAS40XY	40*

- [1] * = -: made in Hong Kong
 * = p: made in Hong Kong
 * = t: made in Malaysia
 * = W: made in China

5. Limiting values

Table 6. Limiting values

In accordance with the Absolute Maximum Rating System (IEC 60134).

Symbol	Parameter	Conditions	Min	Max	Unit
Per diode					
V_R	reverse voltage		-	40	V
I_F	forward current		-	120	mA
I_{FRM}	repetitive peak forward current	$t_p \leq 1 \text{ s}$; $\delta \leq 0.5$	-	120	mA
I_{FSM}	non-repetitive peak forward current	$t_p \leq 10 \text{ ms}$ ^[1]	-	200	mA
T_j	junction temperature		-	150	°C
T_{amb}	ambient temperature		-65	+150	°C
T_{stg}	storage temperature		-65	+150	°C

- [1] $T_j = 25 \text{ °C}$ prior to surge.

6. Thermal characteristics

Table 7. Thermal characteristics

Symbol	Parameter	Conditions	Min	Typ	Max	Unit
Per device						
R _{th(j-a)}	thermal resistance from junction to ambient	in free air [1]				
	SOT23		-	-	500	K/W
	SOT143B		-	-	500	K/W
	SOT363 (1PS88SB48)		-	-	416	K/W
	SOT416		-	-	833	K/W
	SOT666 (BAS40-05V)	[2]	-	-	225	K/W
	SOT666 (BAS40-07V)	[2]	-	-	416	K/W
	SOD123F	[2]	-	-	330	K/W
	SOD323		-	-	450	K/W
	SOD523	[2]	-	-	450	K/W
	SOD882	[2]	-	-	500	K/W
	SOT323		-	-	625	K/W
R _{th(j-sp)}	thermal resistance from junction to solder point					
	SOT363 (BAS40XY)	[3]	-	-	260	K/W

[1] Device mounted on an FR4 Printed-Circuit Board (PCB), single-sided copper, tin-plated and standard footprint.

[2] Reflow soldering is the only recommended soldering method.

[3] Soldering point at pins 2, 3, 5 and 6.

7. Characteristics

Table 8. Characteristics

$T_{amb} = 25\text{ }^{\circ}\text{C}$ unless otherwise specified.

Symbol	Parameter	Conditions	Min	Typ	Max	Unit
Per diode						
V _F	forward voltage	[1]				
		I _F = 1 mA	-	-	380	mV
		I _F = 10 mA	-	-	500	mV
		I _F = 40 mA	-	-	1	V
I _R	reverse current	V _R = 30 V	-	-	1	μA
		V _R = 40 V	-	-	10	μA
C _d	diode capacitance	V _R = 0 V; f = 1 MHz	-	-	5	pF

[1] Pulse test: t_p ≤ 300 μs; δ ≤ 0.02.

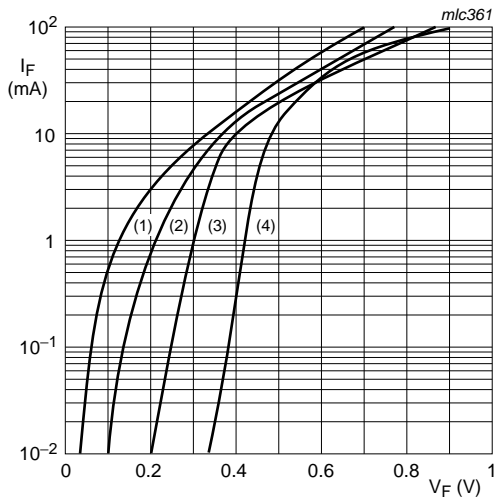

- (1) $T_{\text{amb}} = 125^\circ\text{C}$
- (2) $T_{\text{amb}} = 85^\circ\text{C}$
- (3) $T_{\text{amb}} = 25^\circ\text{C}$
- (4) $T_{\text{amb}} = -40^\circ\text{C}$

Fig 1. Forward current as a function of forward voltage; typical values

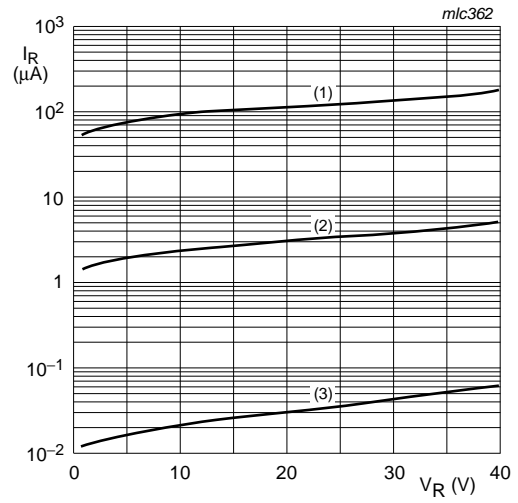

- (1) $T_{\text{amb}} = 125^\circ\text{C}$
- (2) $T_{\text{amb}} = 85^\circ\text{C}$
- (3) $T_{\text{amb}} = 25^\circ\text{C}$

Fig 2. Reverse current as a function of reverse voltage; typical values

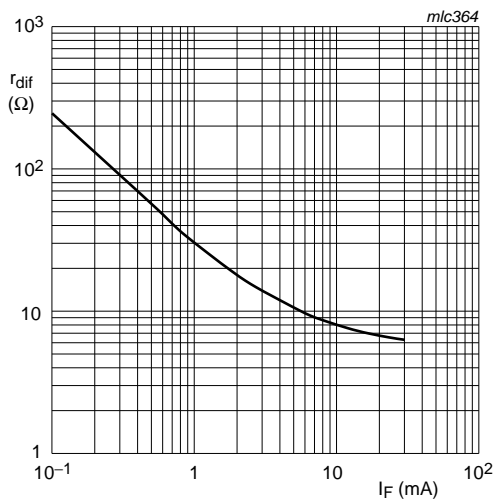

$f = 10\text{ kHz}$

Fig 3. Differential resistance as a function of forward current; typical values

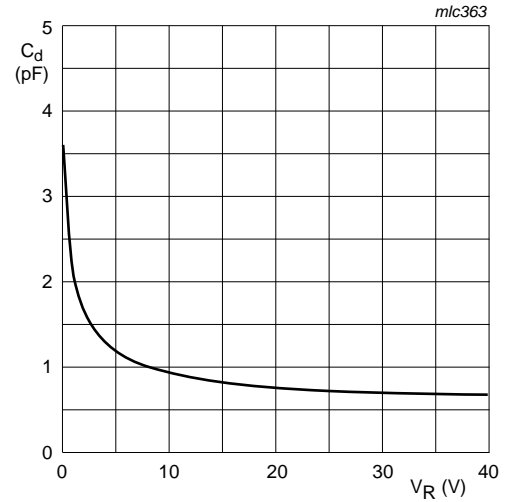

$T_{\text{amb}} = 25^\circ\text{C}; f = 1\text{ MHz}$

Fig 4. Diode capacitance as a function of reverse voltage; typical values

8. Test information

8.1 Quality information

This product has been qualified in accordance with the Automotive Electronics Council (AEC) standard *Q101 - Stress test qualification for discrete semiconductors*, and is suitable for use in automotive applications.

9. Package outline

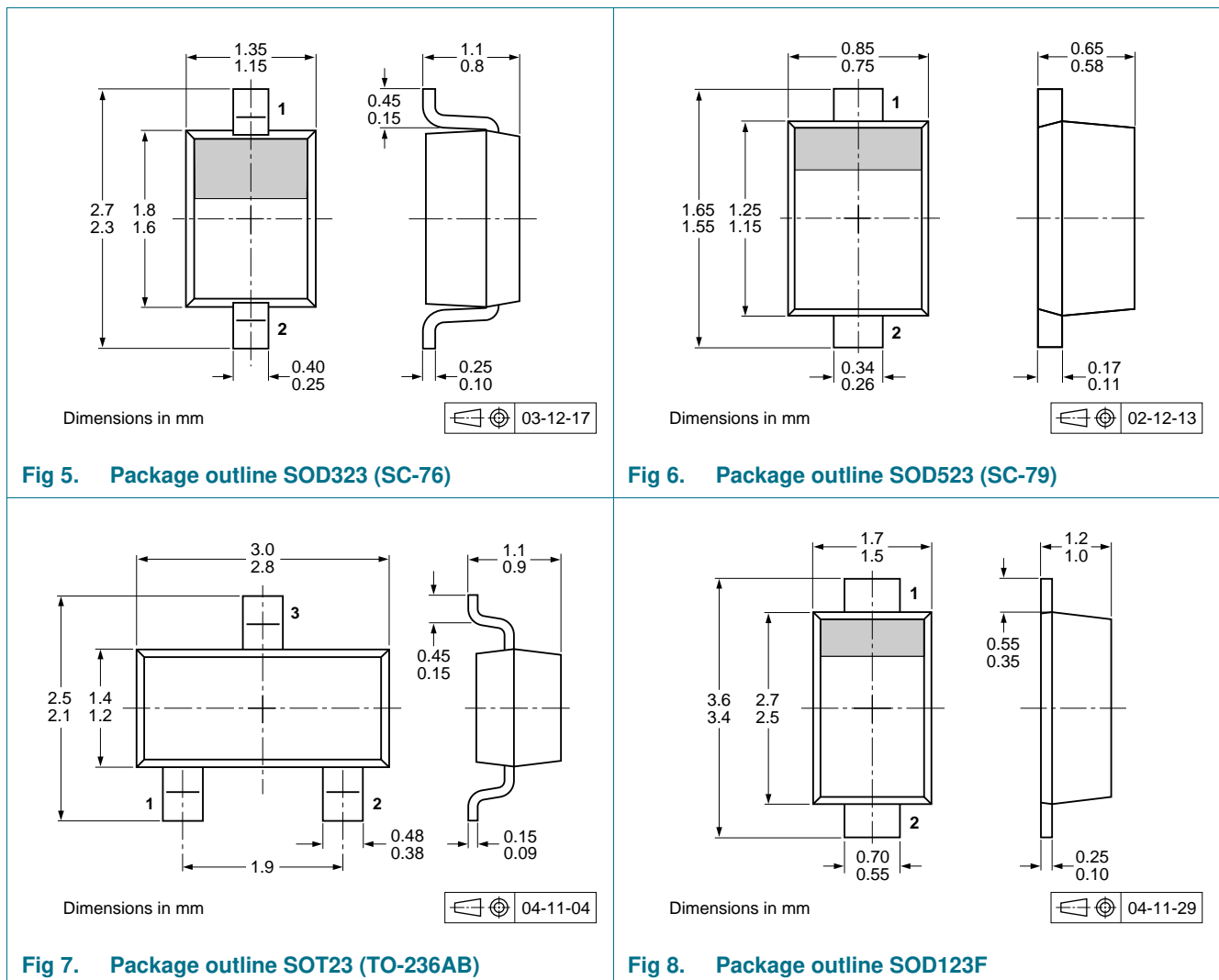

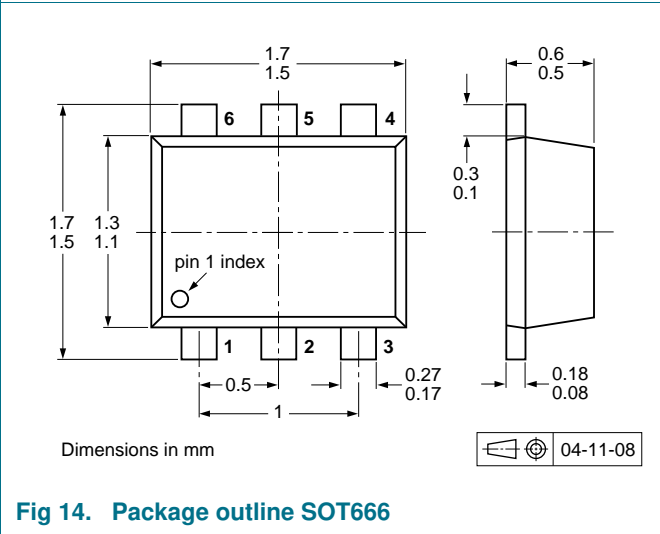
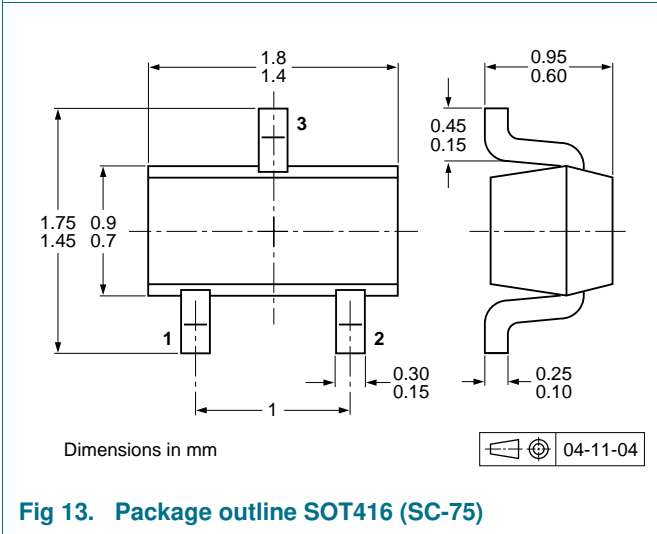
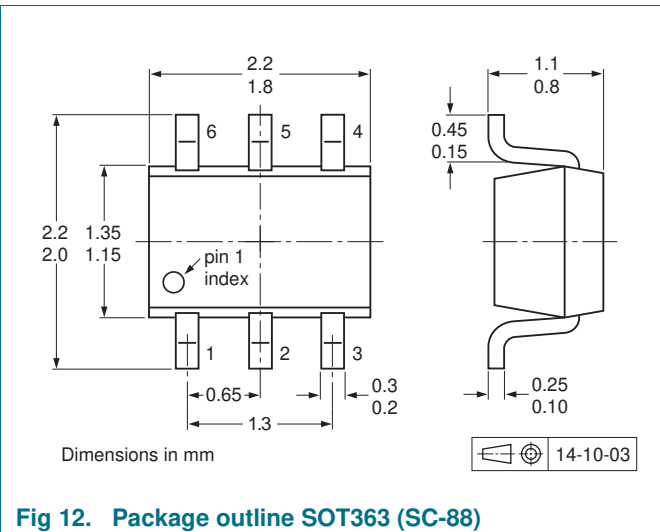
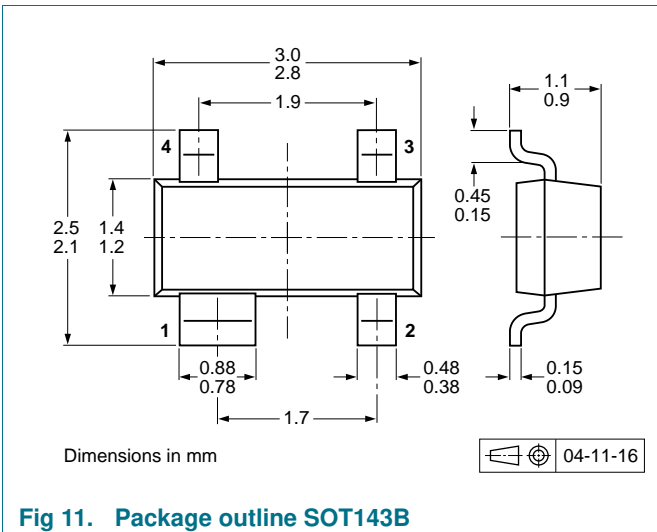
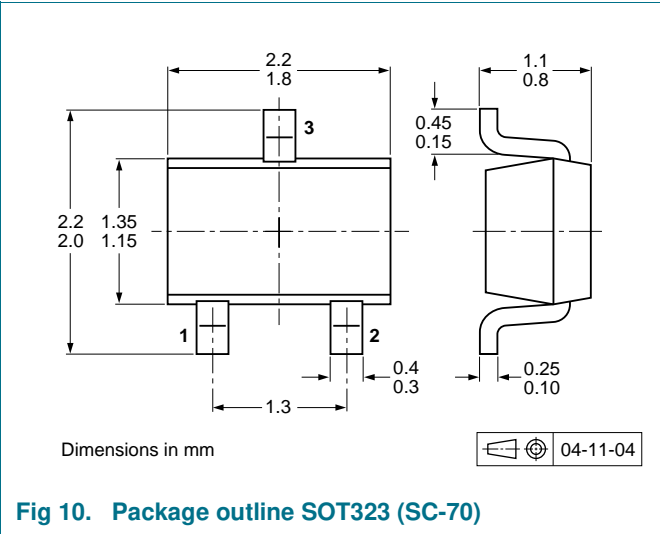
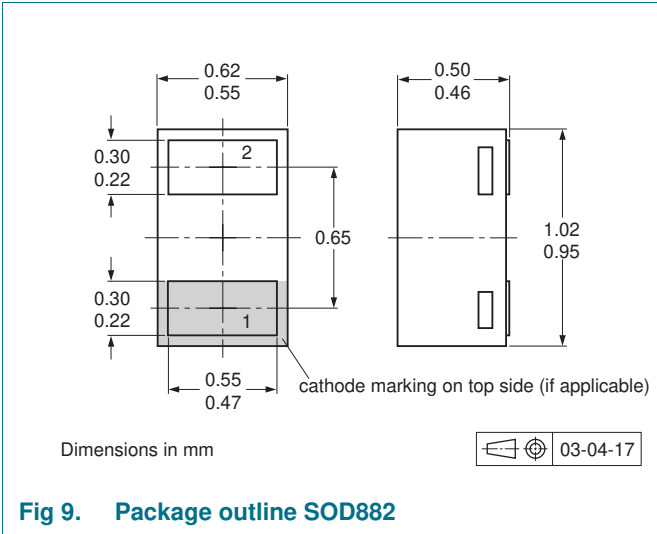

10. Packing information

Table 9. Packing methods

The indicated -xxx are the last three digits of the 12NC ordering code.^[1]

Type number	Package	Description	Packing quantity			
			3000	4000	8000	10000
1PS70SB40	SOT323	4 mm pitch, 8 mm tape and reel	-115	-	-	-135
1PS76SB40	SOD323	4 mm pitch, 8 mm tape and reel	-115	-	-	-135
1PS79SB40	SOD523	2 mm pitch, 8 mm tape and reel	-	-	-315	-
		4 mm pitch, 8 mm tape and reel	-115	-	-	-135
BAS40	SOT23	4 mm pitch, 8 mm tape and reel	-215	-	-	-235
BAS40H	SOD123F	4 mm pitch, 8 mm tape and reel	-115	-	-	-135
BAS40L	SOD882	2 mm pitch, 8 mm tape and reel	-	-	-	-315
BAS40W	SOT323	4 mm pitch, 8 mm tape and reel	-115	-	-	-135
1PS70SB44	SOT323	4 mm pitch, 8 mm tape and reel	-115	-	-	-135
BAS40-04	SOT23	4 mm pitch, 8 mm tape and reel	-215	-	-	-235
BAS40-04W	SOT323	4 mm pitch, 8 mm tape and reel	-115	-	-	-135
1PS70SB45	SOT323	4 mm pitch, 8 mm tape and reel	-115	-	-	-135
1PS75SB45	SOT416	4 mm pitch, 8 mm tape and reel	-115	-	-	-135
BAS40-05	SOT23	4 mm pitch, 8 mm tape and reel	-215	-	-	-235
BAS40-05W	SOT323	4 mm pitch, 8 mm tape and reel	-115	-	-	-135
1PS70SB46	SOT323	4 mm pitch, 8 mm tape and reel	-115	-	-	-135
BAS40-06	SOT23	4 mm pitch, 8 mm tape and reel	-215	-	-	-235
BAS40-06W	SOT323	4 mm pitch, 8 mm tape and reel	-115	-	-	-135
BAS40-07	SOT143B	4 mm pitch, 8 mm tape and reel	-215	-	-	-235
BAS40-07V	SOT666	2 mm pitch, 8 mm tape and reel	-	-	-315	-
		4 mm pitch, 8 mm tape and reel	-	-115	-	-
BAS40-05V	SOT666	2 mm pitch, 8 mm tape and reel	-	-	-315	-
		4 mm pitch, 8 mm tape and reel	-	-115	-	-
1PS88SB48	SOT363	4 mm pitch, 8 mm tape and reel; T1 ^[2]	-115	-	-	-135
		4 mm pitch, 8 mm tape and reel; T2 ^[3]	-125	-	-	-165
BAS40XY	SOT363	4 mm pitch, 8 mm tape and reel; T1 ^[2]	-115	-	-	-135
		4 mm pitch, 8 mm tape and reel; T2 ^[3]	-125	-	-	-165

[1] For further information and the availability of packing methods, see [Section 14](#).

[2] T1: normal taping

[3] T2: reverse taping

11. Soldering

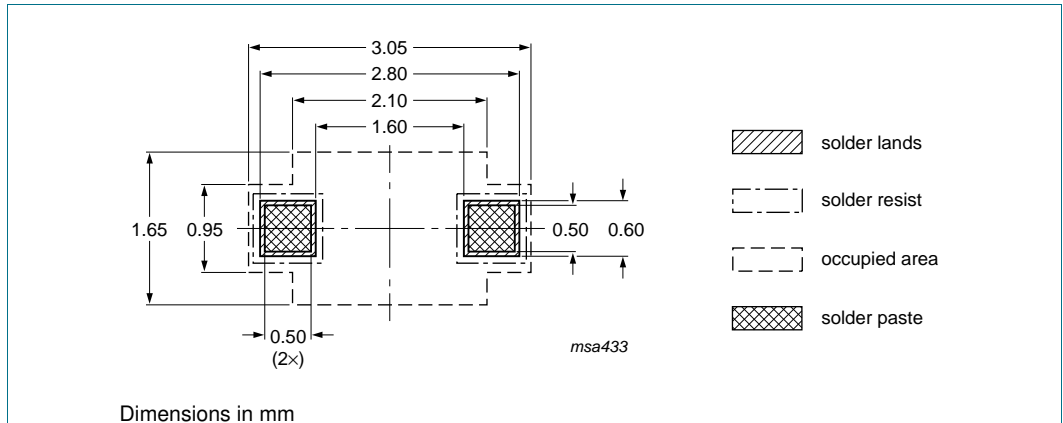

Fig 15. Reflow soldering footprint SOD323 (SC-76)

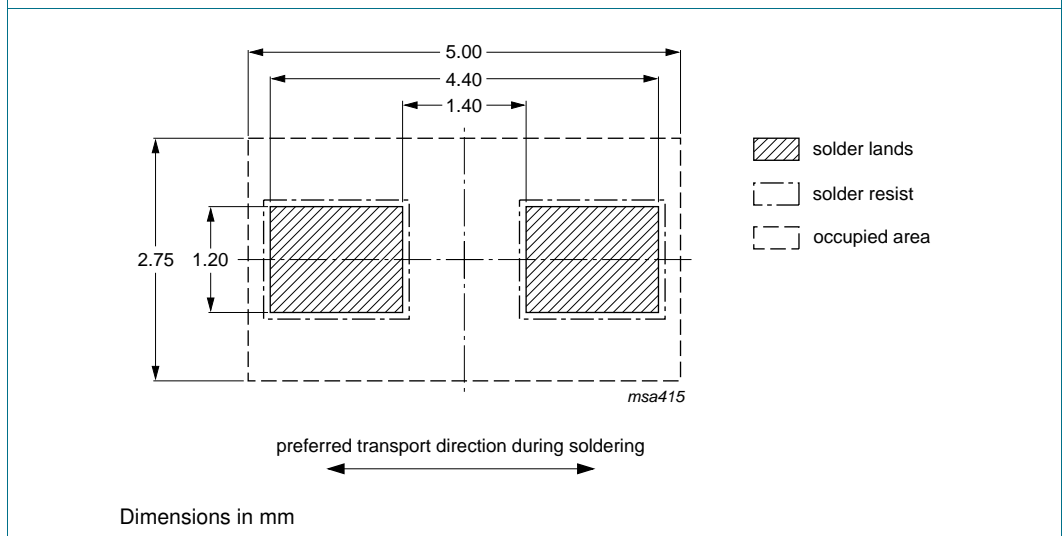

Fig 16. Wave soldering footprint SOD323 (SC-76)

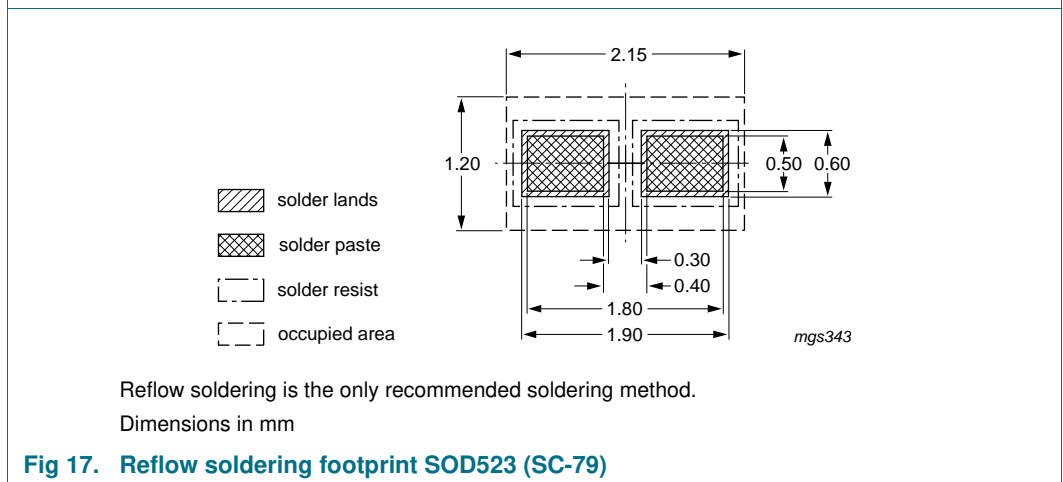
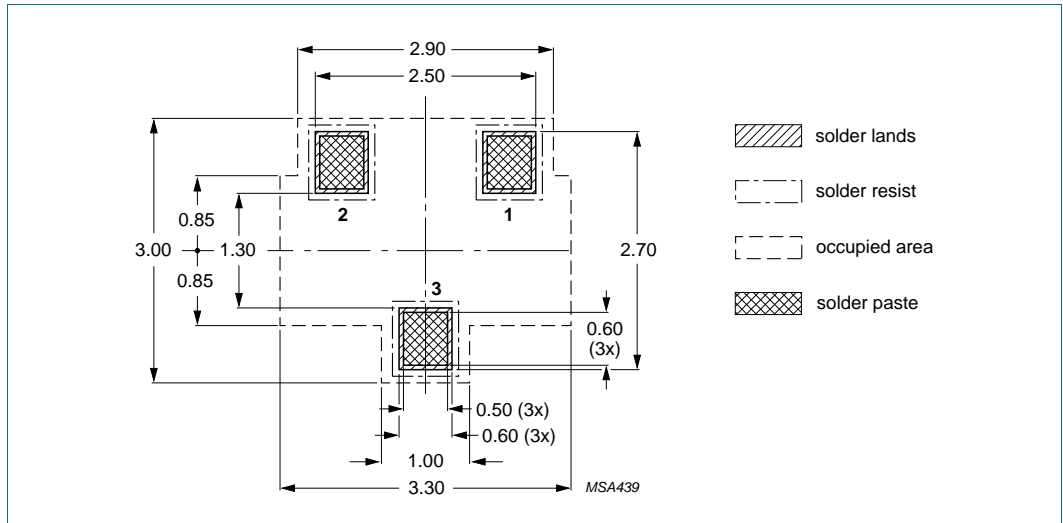
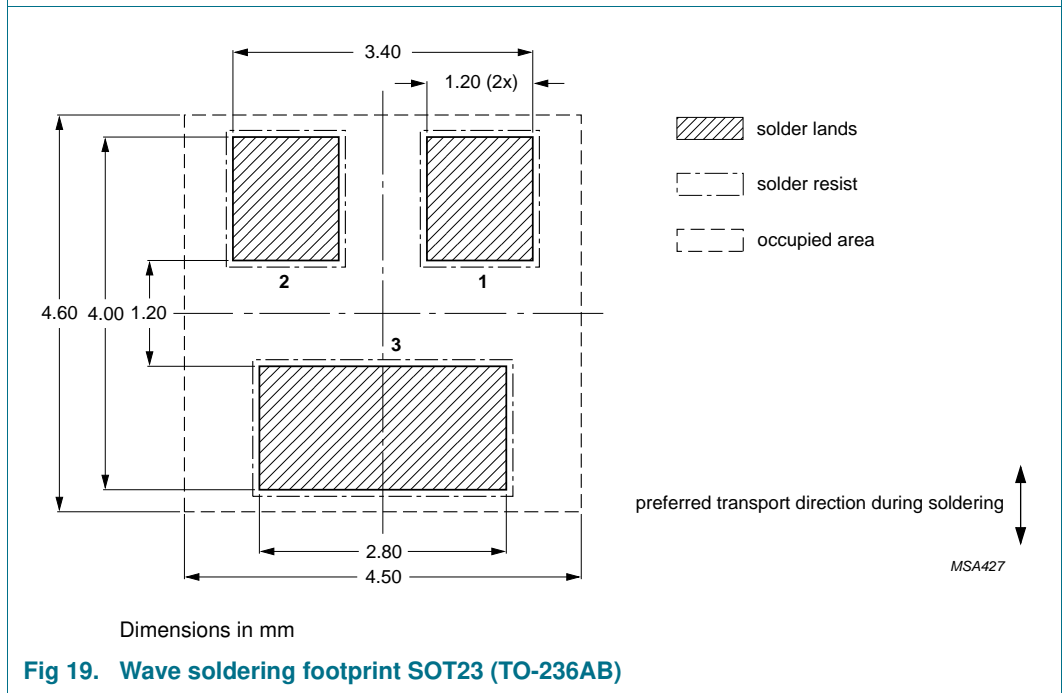

Fig 17. Reflow soldering footprint SOD523 (SC-79)



Dimensions in mm

Fig 18. Reflow soldering footprint SOT23 (TO-236AB)



Dimensions in mm

Fig 19. Wave soldering footprint SOT23 (TO-236AB)

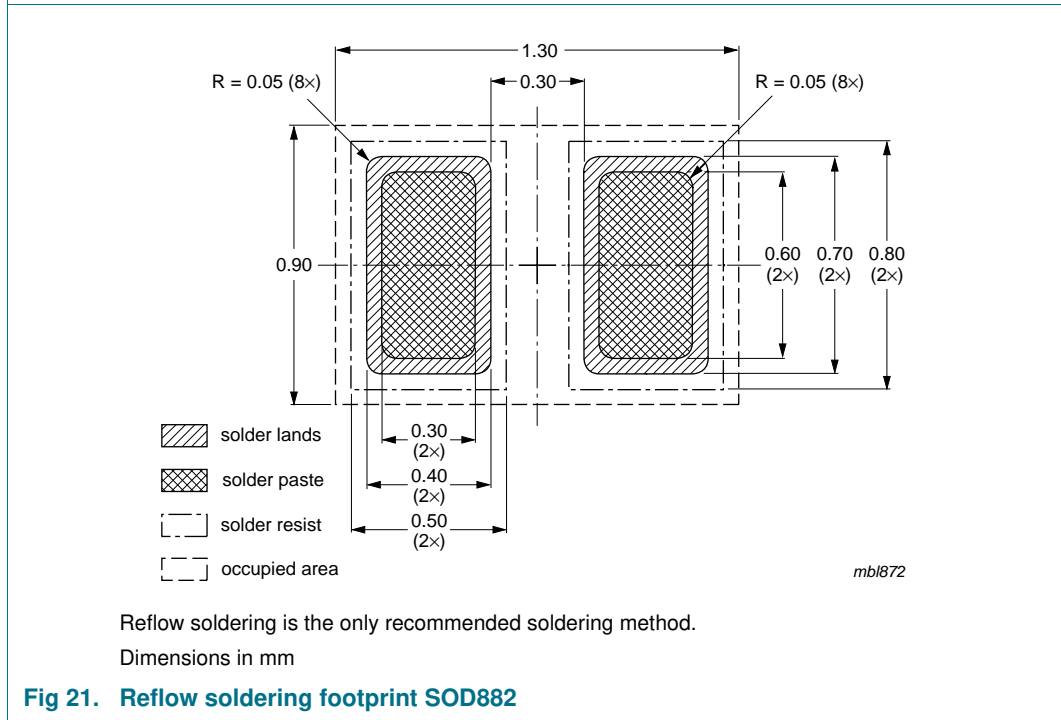
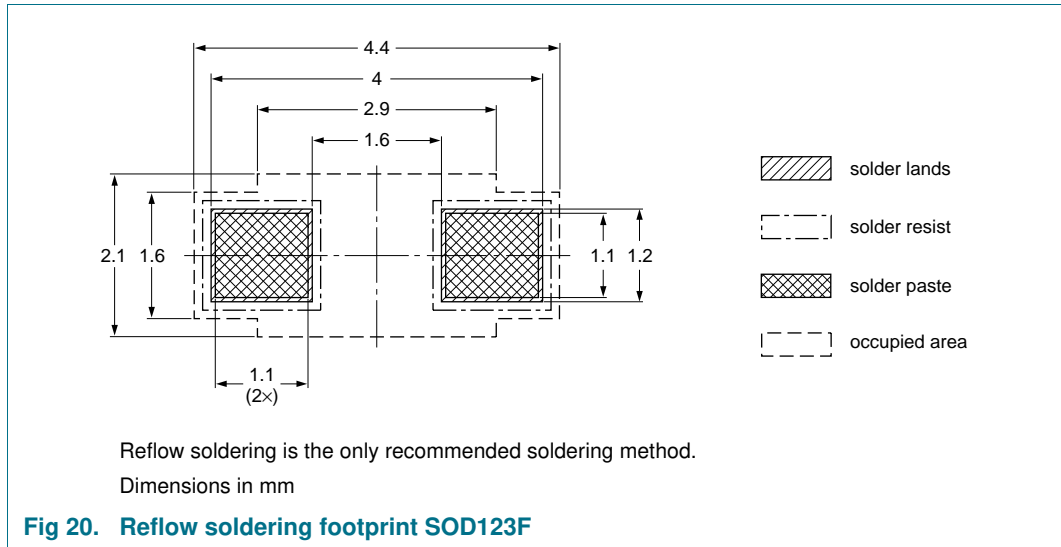

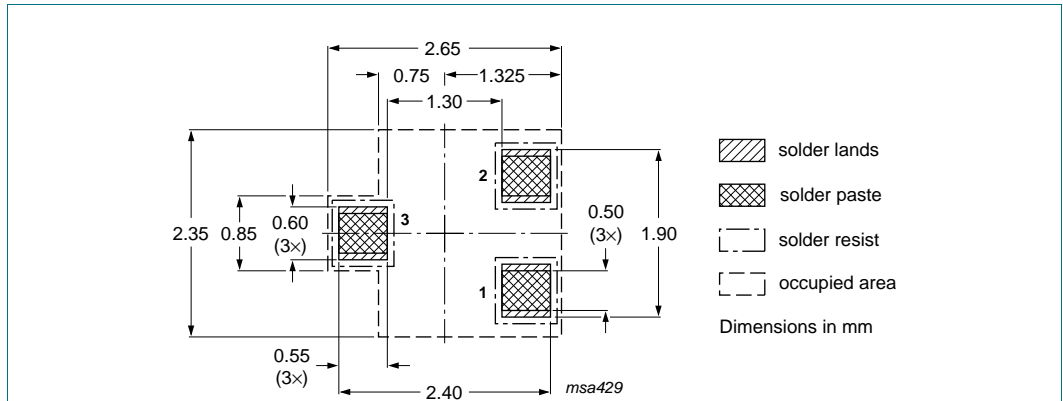

Fig 22. Reflow soldering footprint SOT323 (SC-70)

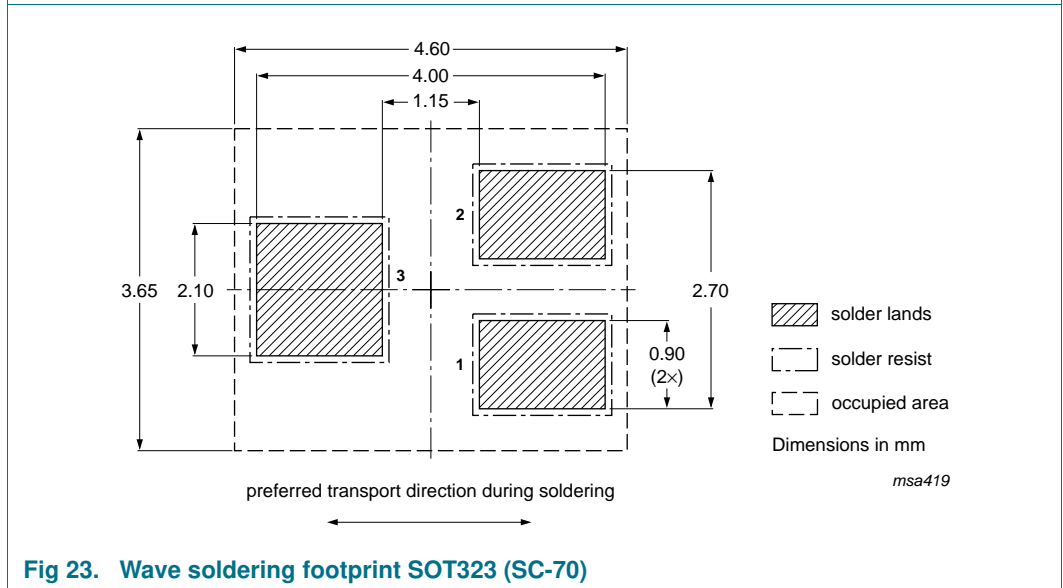

Fig 23. Wave soldering footprint SOT323 (SC-70)

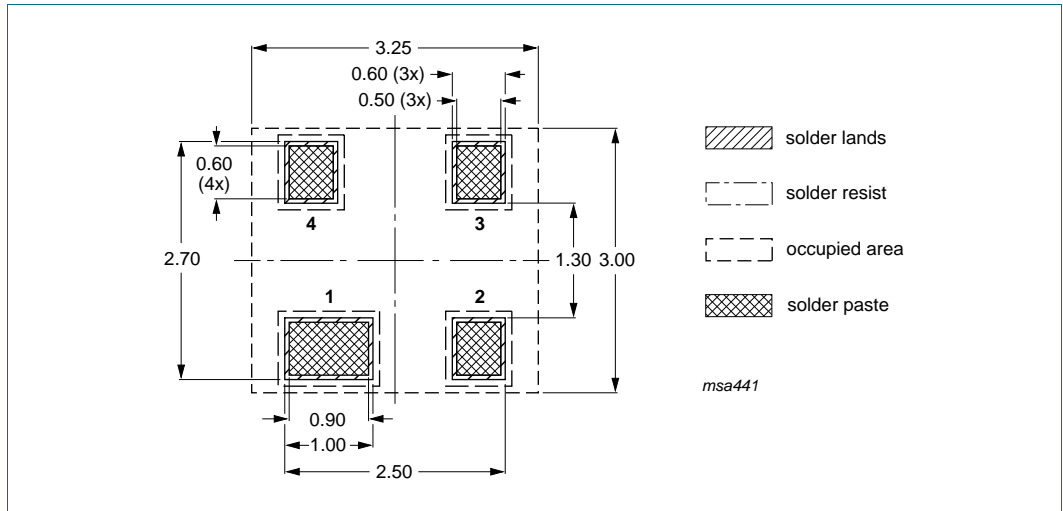

Fig 24. Reflow soldering footprint SOT143B

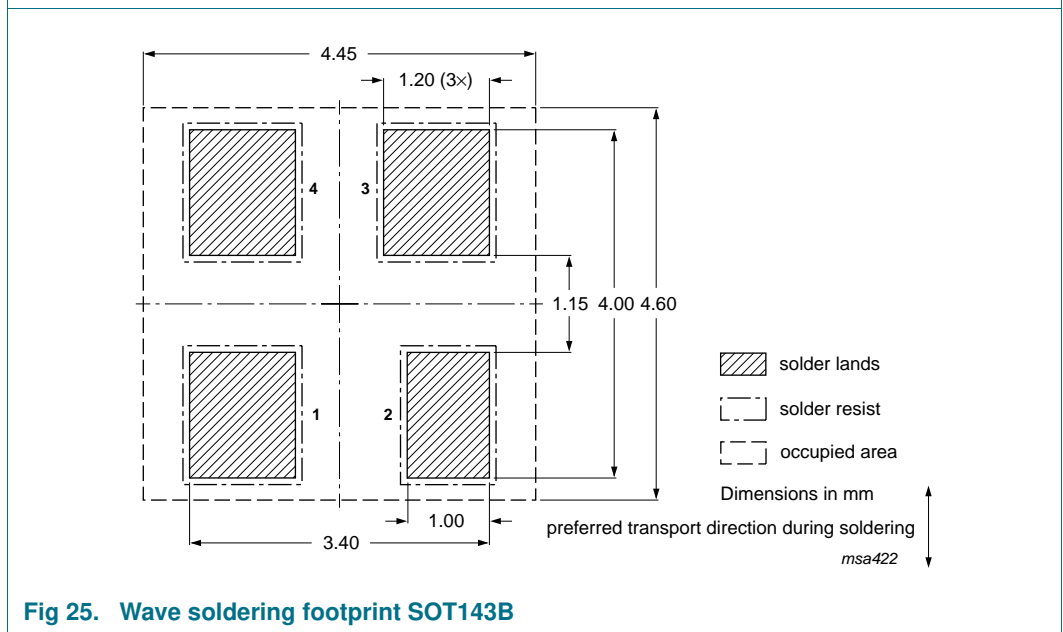

Fig 25. Wave soldering footprint SOT143B

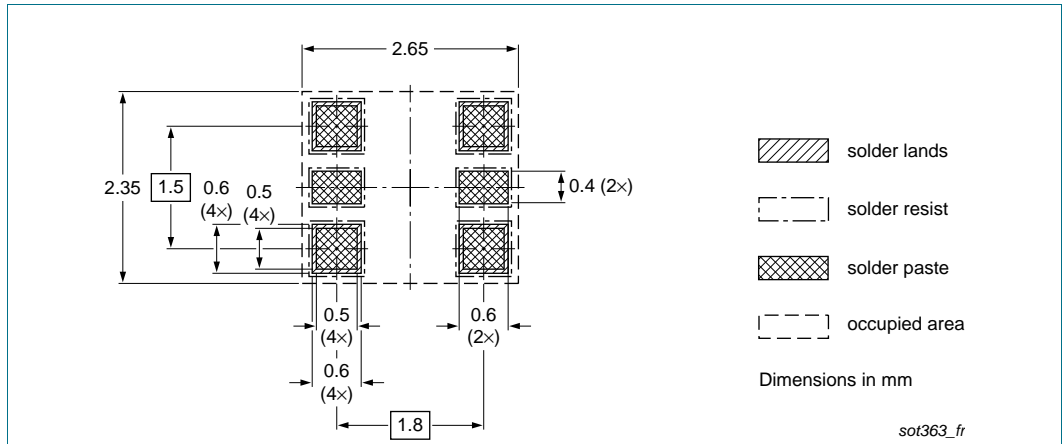

Fig 26. Reflow soldering footprint SOT363 (SC-88)

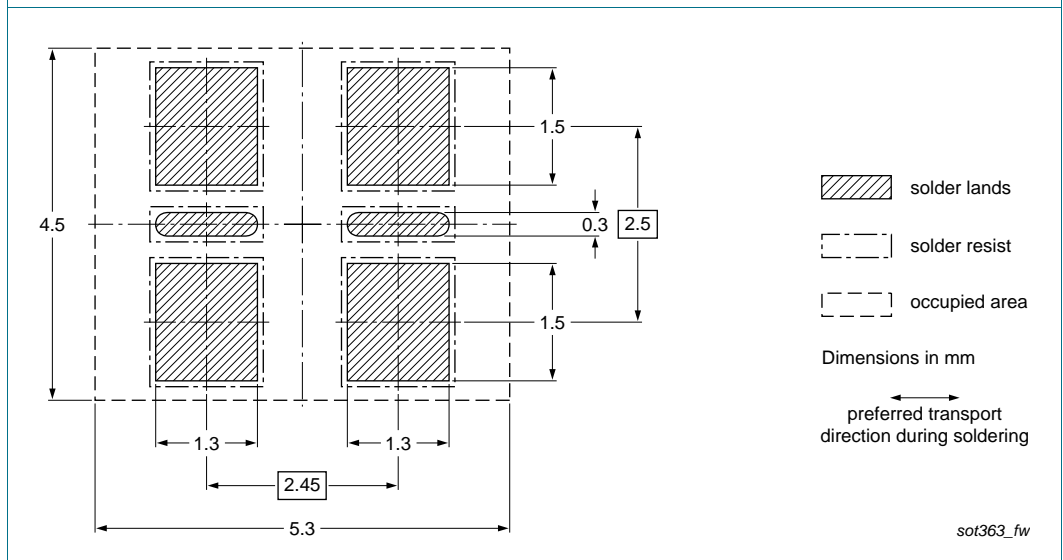

Fig 27. Wave soldering footprint SOT363 (SC-88)

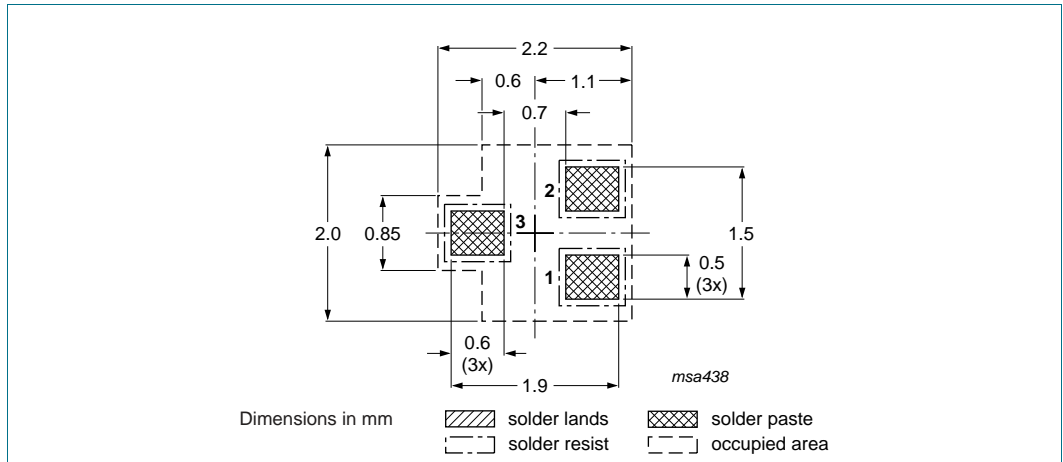

Fig 28. Reflow soldering footprint SOT416

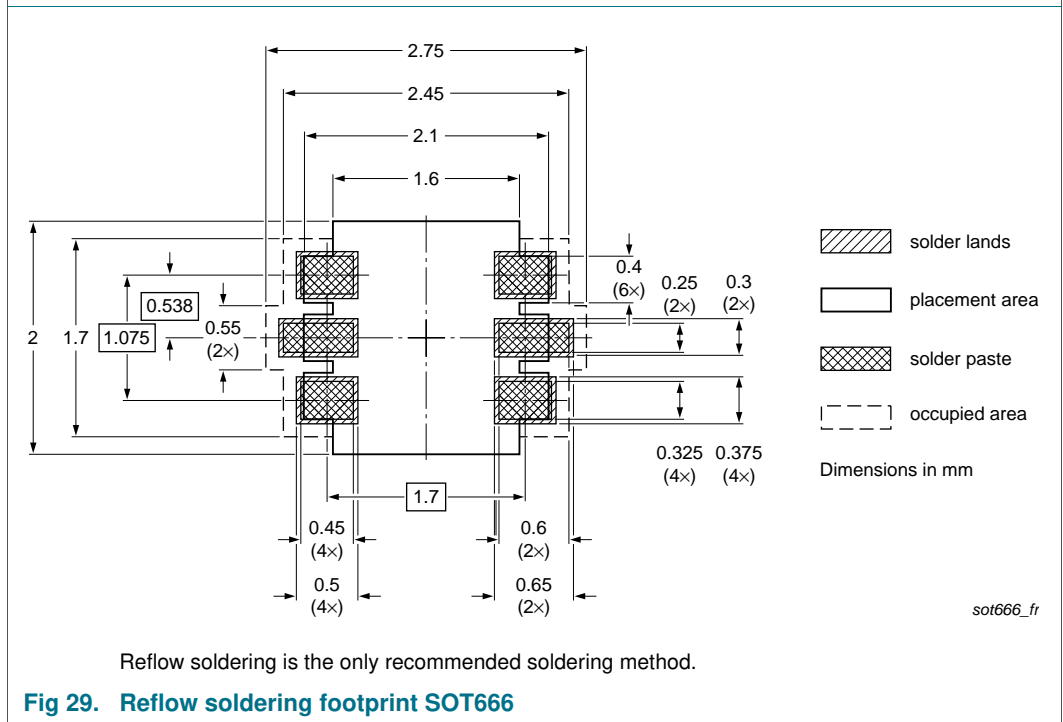

Fig 29. Reflow soldering footprint SOT666

12. Revision history

Table 10. Revision history

Document ID	Release date	Data sheet status	Change notice	Supersedes
BAS40_1PSXXSB4X_SER v.9	20150318	Product data sheet	-	BAS40_1PSXXSB4X_SER_8
Modifications:	<ul style="list-style-type: none"> The format of this data sheet has been redesigned to comply with the new identity guidelines of NXP Semiconductors. Legal texts have been adapted to the new company name where appropriate. 			
BAS40_1PSXXSB4X_SER_8	20100113	Product data sheet	-	BAS40_1PSXXSB4X_SER_7
BAS40_1PSXXSB4X_SER_7	20060512	Product data sheet	-	BAS40_1PSXXSB4X_SER_6
BAS40_1PSXXSB4X_SER_6	20050809	Product data sheet	-	1PS70SB40_3 1PS75SB45_2 1PS76SB40_3 1PS79SB40_2 1PS88SB48_3 BAS40H_1 BAS40L_1 BAS40-05V_1 BAS40-07V_1 BAS40W_3 BAS40_SERIES_5
1PS70SB40_3	19990426	Product specification	-	1PS70SB40_2
1PS75SB45_2	19990426	Product specification	-	1PS75SB45_1
1PS76SB40_3	20040126	Product specification	-	1PS76SB40_2
1PS79SB40_2	19990426	Product specification	-	1PS79SB40_1
1PS88SB48_3	20021107	Product specification	-	1PS88SB48_2
BAS40H_1	20050425	Product data sheet	-	-
BAS40L_1	20030520	Product specification	-	-
BAS40-05V_1	20021121	Product specification	-	-
BAS40-07V_1	20020327	Product specification	-	-
BAS40W_3	19990426	Product specification	-	BAS40W_2
BAS40_SERIES_5	20011010	Product specification	-	BAS40_4

13. Legal information

13.1 Data sheet status

Document status ^{[1][2]}	Product status ^[3]	Definition
Objective [short] data sheet	Development	This document contains data from the objective specification for product development.
Preliminary [short] data sheet	Qualification	This document contains data from the preliminary specification.
Product [short] data sheet	Production	This document contains the product specification.

[1] Please consult the most recently issued document before initiating or completing a design.

[2] The term 'short data sheet' is explained in section "Definitions".

[3] The product status of device(s) described in this document may have changed since this document was published and may differ in case of multiple devices. The latest product status information is available on the Internet at URL <http://www.nxp.com>.

13.2 Definitions

Draft — The document is a draft version only. The content is still under internal review and subject to formal approval, which may result in modifications or additions. NXP Semiconductors does not give any representations or warranties as to the accuracy or completeness of information included herein and shall have no liability for the consequences of use of such information.

Short data sheet — A short data sheet is an extract from a full data sheet with the same product type number(s) and title. A short data sheet is intended for quick reference only and should not be relied upon to contain detailed and full information. For detailed and full information see the relevant full data sheet, which is available on request via the local NXP Semiconductors sales office. In case of any inconsistency or conflict with the short data sheet, the full data sheet shall prevail.

Product specification — The information and data provided in a Product data sheet shall define the specification of the product as agreed between NXP Semiconductors and its customer, unless NXP Semiconductors and customer have explicitly agreed otherwise in writing. In no event however, shall an agreement be valid in which the NXP Semiconductors product is deemed to offer functions and qualities beyond those described in the Product data sheet.

13.3 Disclaimers

Limited warranty and liability — Information in this document is believed to be accurate and reliable. However, NXP Semiconductors does not give any representations or warranties, expressed or implied, as to the accuracy or completeness of such information and shall have no liability for the consequences of use of such information. NXP Semiconductors takes no responsibility for the content in this document if provided by an information source outside of NXP Semiconductors.

In no event shall NXP Semiconductors be liable for any indirect, incidental, punitive, special or consequential damages (including - without limitation - lost profits, lost savings, business interruption, costs related to the removal or replacement of any products or rework charges) whether or not such damages are based on tort (including negligence), warranty, breach of contract or any other legal theory.

Notwithstanding any damages that customer might incur for any reason whatsoever, NXP Semiconductors' aggregate and cumulative liability towards customer for the products described herein shall be limited in accordance with the *Terms and conditions of commercial sale* of NXP Semiconductors.

Right to make changes — NXP Semiconductors reserves the right to make changes to information published in this document, including without limitation specifications and product descriptions, at any time and without notice. This document supersedes and replaces all information supplied prior to the publication hereof.

Suitability for use in automotive applications — This NXP Semiconductors product has been qualified for use in automotive applications. Unless otherwise agreed in writing, the product is not designed, authorized or warranted to be suitable for use in life support, life-critical or safety-critical systems or equipment, nor in applications where failure or malfunction of an NXP Semiconductors product can reasonably be expected to result in personal injury, death or severe property or environmental damage. NXP Semiconductors and its suppliers accept no liability for inclusion and/or use of NXP Semiconductors products in such equipment or applications and therefore such inclusion and/or use is at the customer's own risk.

Applications — Applications that are described herein for any of these products are for illustrative purposes only. NXP Semiconductors makes no representation or warranty that such applications will be suitable for the specified use without further testing or modification.

Customers are responsible for the design and operation of their applications and products using NXP Semiconductors products, and NXP Semiconductors accepts no liability for any assistance with applications or customer product design. It is customer's sole responsibility to determine whether the NXP Semiconductors product is suitable and fit for the customer's applications and products planned, as well as for the planned application and use of customer's third party customer(s). Customers should provide appropriate design and operating safeguards to minimize the risks associated with their applications and products.

NXP Semiconductors does not accept any liability related to any default, damage, costs or problem which is based on any weakness or default in the customer's applications or products, or the application or use by customer's third party customer(s). Customer is responsible for doing all necessary testing for the customer's applications and products using NXP Semiconductors products in order to avoid a default of the applications and the products or of the application or use by customer's third party customer(s). NXP does not accept any liability in this respect.

Limiting values — Stress above one or more limiting values (as defined in the Absolute Maximum Ratings System of IEC 60134) will cause permanent damage to the device. Limiting values are stress ratings only and (proper) operation of the device at these or any other conditions above those given in the Recommended operating conditions section (if present) or the Characteristics sections of this document is not warranted. Constant or repeated exposure to limiting values will permanently and irreversibly affect the quality and reliability of the device.

Terms and conditions of commercial sale — NXP Semiconductors products are sold subject to the general terms and conditions of commercial sale, as published at <http://www.nxp.com/profile/terms>, unless otherwise agreed in a valid written individual agreement. In case an individual agreement is concluded only the terms and conditions of the respective agreement shall apply. NXP Semiconductors hereby expressly objects to applying the customer's general terms and conditions with regard to the purchase of NXP Semiconductors products by customer.

No offer to sell or license — Nothing in this document may be interpreted or construed as an offer to sell products that is open for acceptance or the grant, conveyance or implication of any license under any copyrights, patents or other industrial or intellectual property rights.

Quick reference data — The Quick reference data is an extract of the product data given in the Limiting values and Characteristics sections of this document, and as such is not complete, exhaustive or legally binding.

Export control — This document as well as the item(s) described herein may be subject to export control regulations. Export might require a prior authorization from competent authorities.

Translations — A non-English (translated) version of a document is for reference only. The English version shall prevail in case of any discrepancy between the translated and English versions.

13.4 Trademarks

Notice: All referenced brands, product names, service names and trademarks are the property of their respective owners.

14. Contact information

For more information, please visit: <http://www.nxp.com>

For sales office addresses, please send an email to: salesaddresses@nxp.com

15. Contents

1	Product profile	1
1.1	General description	1
1.2	Features and benefits	2
1.3	Applications	2
1.4	Quick reference data	2
2	Pinning information	2
3	Ordering information	5
4	Marking	6
5	Limiting values	6
6	Thermal characteristics	7
7	Characteristics	7
8	Test information	9
8.1	Quality information	9
9	Package outline	9
10	Packing information	11
11	Soldering	12
12	Revision history	19
13	Legal information	20
13.1	Data sheet status	20
13.2	Definitions	20
13.3	Disclaimers	20
13.4	Trademarks	21
14	Contact information	21
15	Contents	22

Please be aware that important notices concerning this document and the product(s) described herein, have been included in section 'Legal information'.

© NXP Semiconductors N.V. 2015. All rights reserved.

For more information, please visit: <http://www.nxp.com>

For sales office addresses, please send an email to: salesaddresses@nxp.com

Date of release: 18 March 2015

Document identifier: BAS40_1PSXXSB4X_SER