

DRD RIGHT ANGLE
PC MOUNT

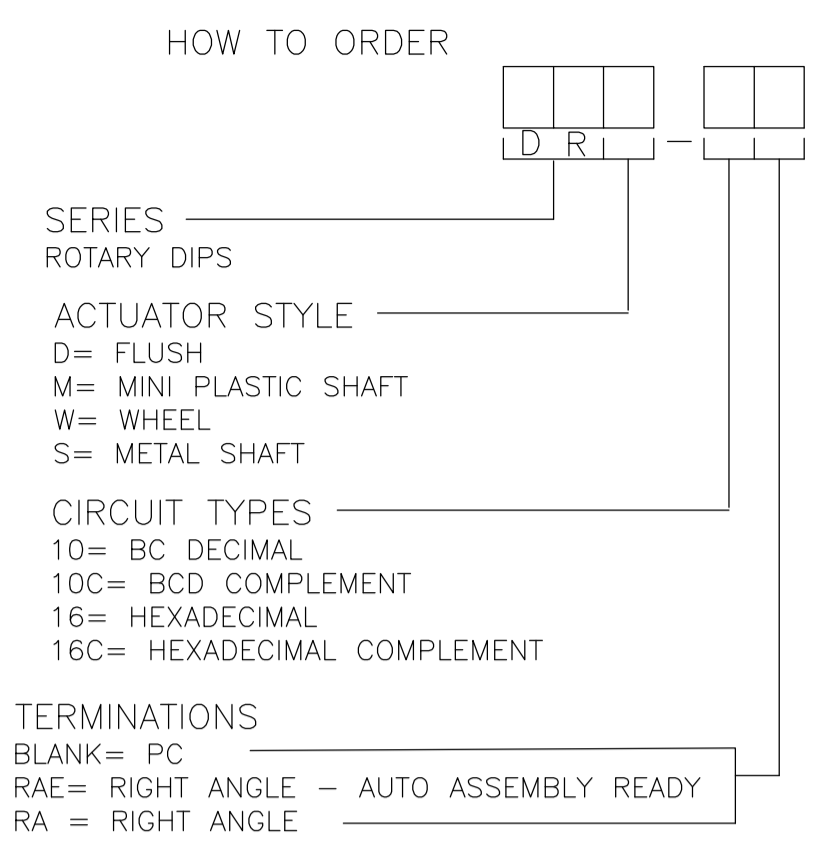

SPECIFICATIONS:

MATERIAL:
FRAME & CASE- PPS UL94V-0, BLACK
ROTOR, PA6T UL94V-0, COLOR SEE P/N TABLE
FIXED CONTACT/TERMINAL- COPPER ALLOY, GOLD FLASH OVER NICKEL PLATE
MOVING CONTACT- COPPER ALLOY, GOLD FLASH OVER NICKEL PLATE
BALL SUPPORT PLATE- COPPER ALLOY
BALL- STAINLESS STEEL
DETENT SPRING- STAINLESS STEEL
BUSHING (DRS)- ZINC DIE CAST
SHAFT (DRS)- COPPER ALLOY- NICKEL PLATE

ELECTRICAL:
CONTACT RATING- 0.4VA@ 20V DC OR PEAK AC
INITIAL CONTACT RESISTANCE- 50 MILLIOHMS MAX
INSULATION RESISTANCE- 1,000 MEGOHMS@100V DC
DIELECTRIC STRENGTH- 300V AC
LIFE EXPECTANCY- 10,000 ROTATIONS

MECHANICAL:
OPERATING FORCE- 13.88 OZF.IN. MAX

ENVIRONMENTAL:
OPERATING TEMPERATURE- -30°C TO +85°C
STORAGE TEMPERATURE- -45°C TO +100°C
RESISTANCE TO SOLDER HEAT-PER 109-202, COND B (THRU-HOLE)
SOLDERABILITY-PER JIS C 0050 & JIS C 0053

- NOTES:**
- ALL MATERIALS AND FINISHES SHALL COMPLY WITH EU DIRECTIVE 2002/95/EC OF 27JAN2003 (ROHS)
 - COMMON TERMINALS ARE CONNECTED INTERNALLY, EXCEPT ON HYBRID VERSIONS.
 - RED ROTOR WITH WHITE PRINTING ON TOP AND SIDE OF SWITCH. "S" STYLES HAVE NOT PRINTING ON TOP.
 - BLACK ROTOR WITH WHITE PRINTING ON TOP AND SIDE OF SWITCH. "S" STYLES HAVE NO PRINTING ON TOP.
 - ORANGE ROTOR WITH WHITE PRINTING ON TOP AND SIDE OF SWITCH "S" STYLES HAVE NO PRINTING ON TOP.
 - WHITE ROTOR WITH WHITE PRINTING ON TOP AND SIDE OF SWITCH "S" STYLE HAVE NO PRINTING ON TOP.
- △ LOCATE 'ALCO' TRADE NAME AND LOT NUMBER MARKING. LOT NUMBER TO BE MARKED AS FOLLOW:
- 4 F
1ST DIGIT 2ND DIGIT
YEAR 1194 MONTH 6
- MARK WITH PERMANENT WHITE INK.

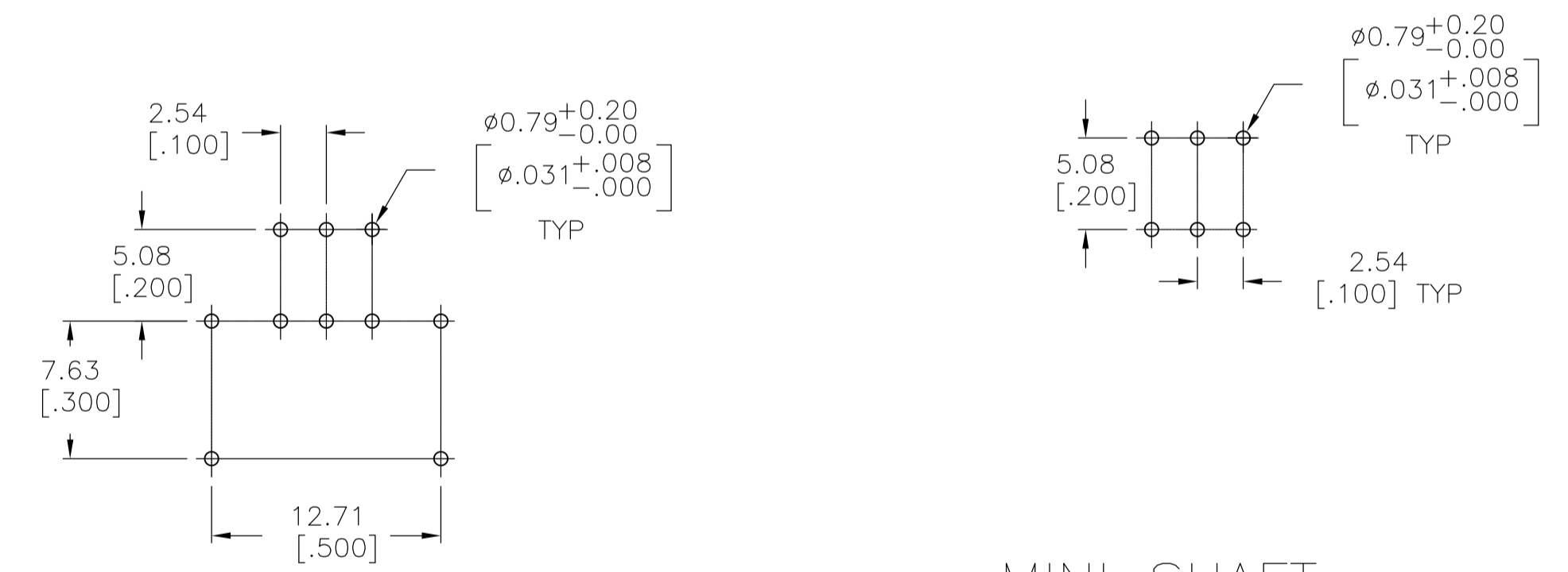

"S" STYLE

MINI SHAFT
FLUSH
WHEEL

PRINTED CIRCUIT BOARD LAYOUTS

BLACK	DRW16RAE04	1-1825008-6
WHITE	DRW16CRAE04	1-1825008-5
RED	DRW10RAE04	1-1825008-4
ORANGE	DRW10CRAE04	1-1825008-3
N/A	DRS16RA04	1-1825008-2
N/A	DRS16CRA04	1-1825008-1
N/A	DRS10RA04	1-1825008-0
N/A	DRS10CRAE04	1825008-9
BLACK	DRM16RAE04	1825008-8
WHITE	DRM16CRAE04	1825008-7
RED	DRM10RAE04	1825008-6
ORANGE	DRM10CRAE04	1825008-5
BLACK	DRD16RAE04	1825008-4
WHITE	DRD16CRAE04	1825008-3
RED	DRD10RAE04	1825008-2
ORANGE	DRD10CRAE04	1825008-1
ROTOR COLOR	T&B P/N	PART NO.

THIS DRAWING IS A CONTROLLED DOCUMENT. DIN 9139 S.VISWESWARA 17MAY2005
CHK: M.S.SARVER
APVD: -

DIMENSIONS: mm [INCHES]	TOLERANCES UNLESS OTHERWISE SPECIFIED:	PRODUCT SPEC	NAME
0. PLC ± -	1. PLC ± -	APPLICATION SPEC	DR***RA SERIES ROTARY DIP SWITCH
2. PLC ± 0.25	3. PLC ± -		
4. PLC ± -	ANGLES ± 1°		

MATERIAL: - FINISH: - WEIGHT: - SIZE: A1 CAGE CODE: 00779 DRAWING NO: 1825008 RESTRICTED TO: -
CUSTOMER DRAWING SCALE: 4:1 SHEET: 1 OF 2 REV: A4

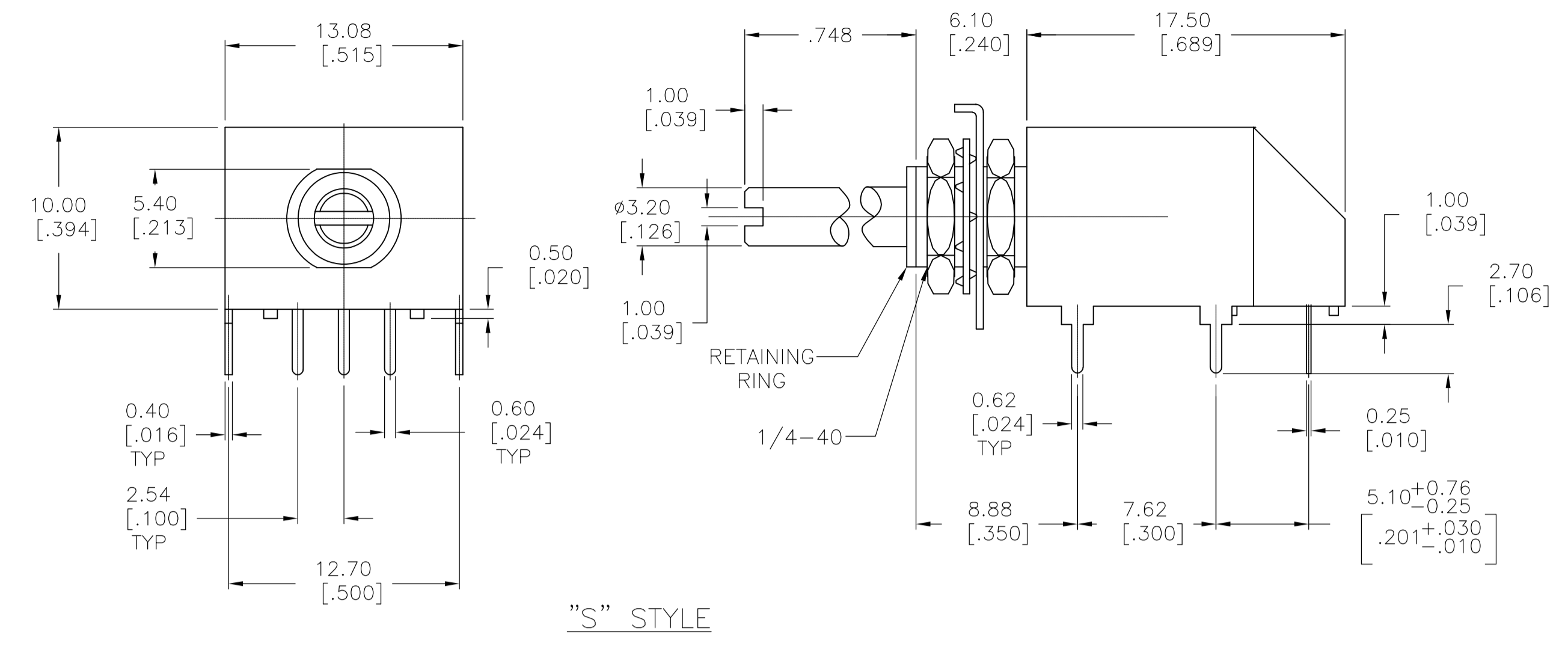

"S" STYLE

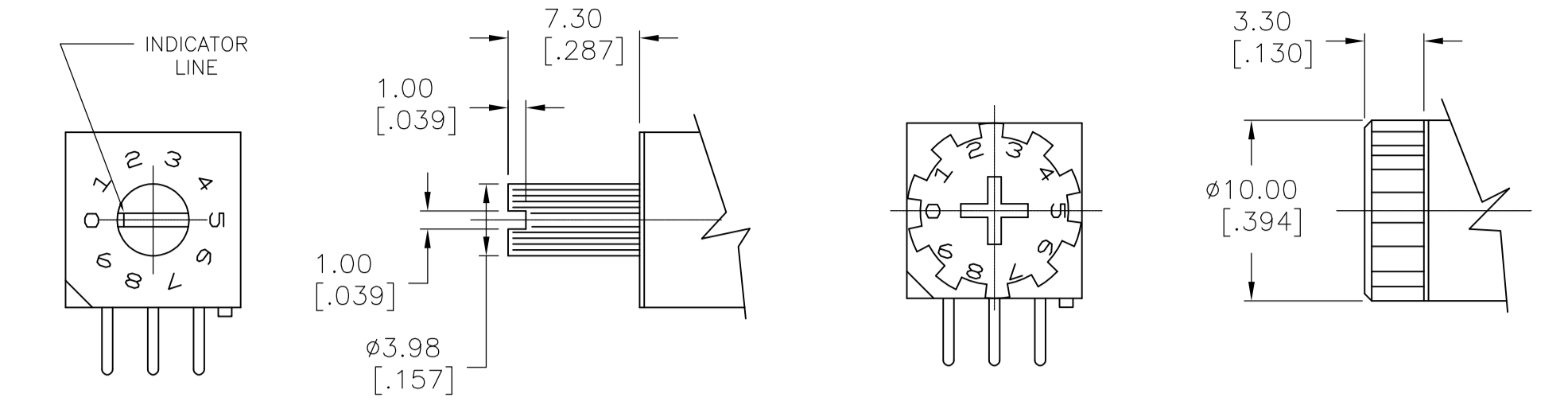

MINI SHAFT
'M' STYLE

WHEEL
'W' STYLE

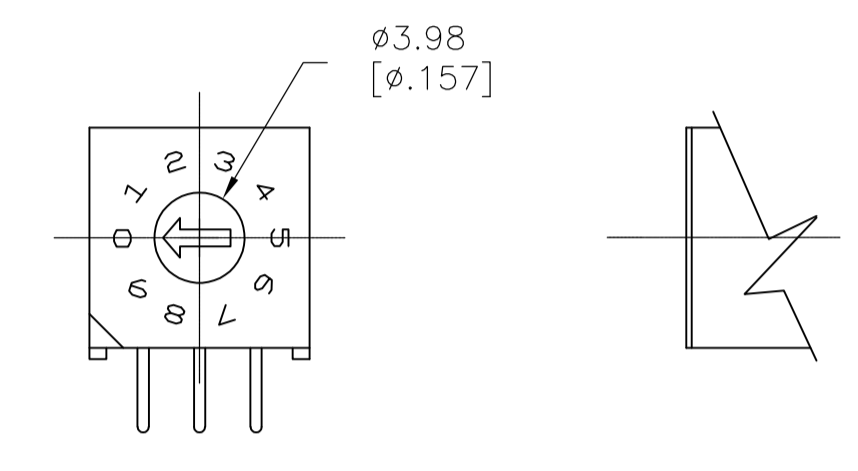

'D' STYLE

TERMINAL IDENTIFICATION FOR DR SERIES ONLY
(VIEWED FROM BOTTOM OF SWITCH)

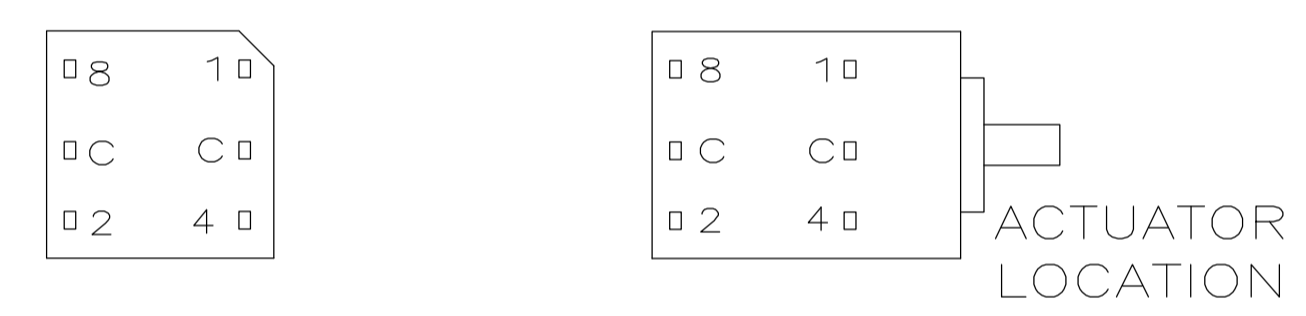

ACTUATORS
SCALE:3:1

10-POSITION, BCD SEE NOTE 3

POS	0	1	2	3	4	5	6	7	8	9
C	X	X	X	X	X	X	X	X	X	X
1		X		X		X		X		X
2			X	X			X	X		
4					X	X	X	X		
8									X	X

16-POSITION, HEXADECIMAL SEE NOTE 4

POS	0	1	2	3	4	5	6	7	8	9	A	B	C	D	E	F
C	X	X	X	X	X	X	X	X	X	X	X	X	X	X	X	X
1		X		X		X		X		X		X		X		X
2			X	X			X	X			X	X			X	X
4					X	X	X	X					X	X	X	X
8									X	X	X	X	X	X	X	X

10 POSITION, BCD COMPLEMENT SEE NOTE 5

POS	0	1	2	3	4	5	6	7	8	9
C̄	X	X	X	X	X	X	X	X	X	X
1̄	X		X		X		X		X	
2̄	X	X			X	X			X	X
4̄	X	X	X	X					X	X
8̄	X	X	X	X	X	X	X	X		

16-POSITION, HEXADECIMAL COMPLEMENT SEE NOTE 6

POS	0	1	2	3	4	5	6	7	8	9	A	B	C	D	E	F
C̄	X	X	X	X	X	X	X	X	X	X	X	X	X	X	X	X
1̄	X		X		X		X		X		X		X		X	
2̄	X	X			X	X			X	X			X	X		
4̄	X	X	X	X					X	X	X	X				
8̄	X	X	X	X	X	X	X	X								

THIS DRAWING IS A CONTROLLED DOCUMENT.

DIMENSIONS: mm [INCHES]	TOLERANCES UNLESS OTHERWISE SPECIFIED:	DIN E.S.VISWESWARA 17MAY2005	STE TE Connectivity
0 PLC ± -	1 PLC ± -	CHK M.S.SARVER	NAME
2 PLC ± 0.25	3 PLC ± -	APVD	PRODUCT SPEC
4 PLC ± -	ANGLES ± 1°		APPLICATION SPEC
MATERIAL	FINISH	WEIGHT	RESTRICTED TO
		A1 00779	SIZE CASE CODE DRAWING NO
		1825008	SCALE 4:1 SHEET 2 OF 2 REV A4
		CUSTOMER DRAWING	