

PART NUMBER	REV	FIRST USED
680709-1	B	122500-1
680709-2	B	565435-5
680709-3	B	354500-1

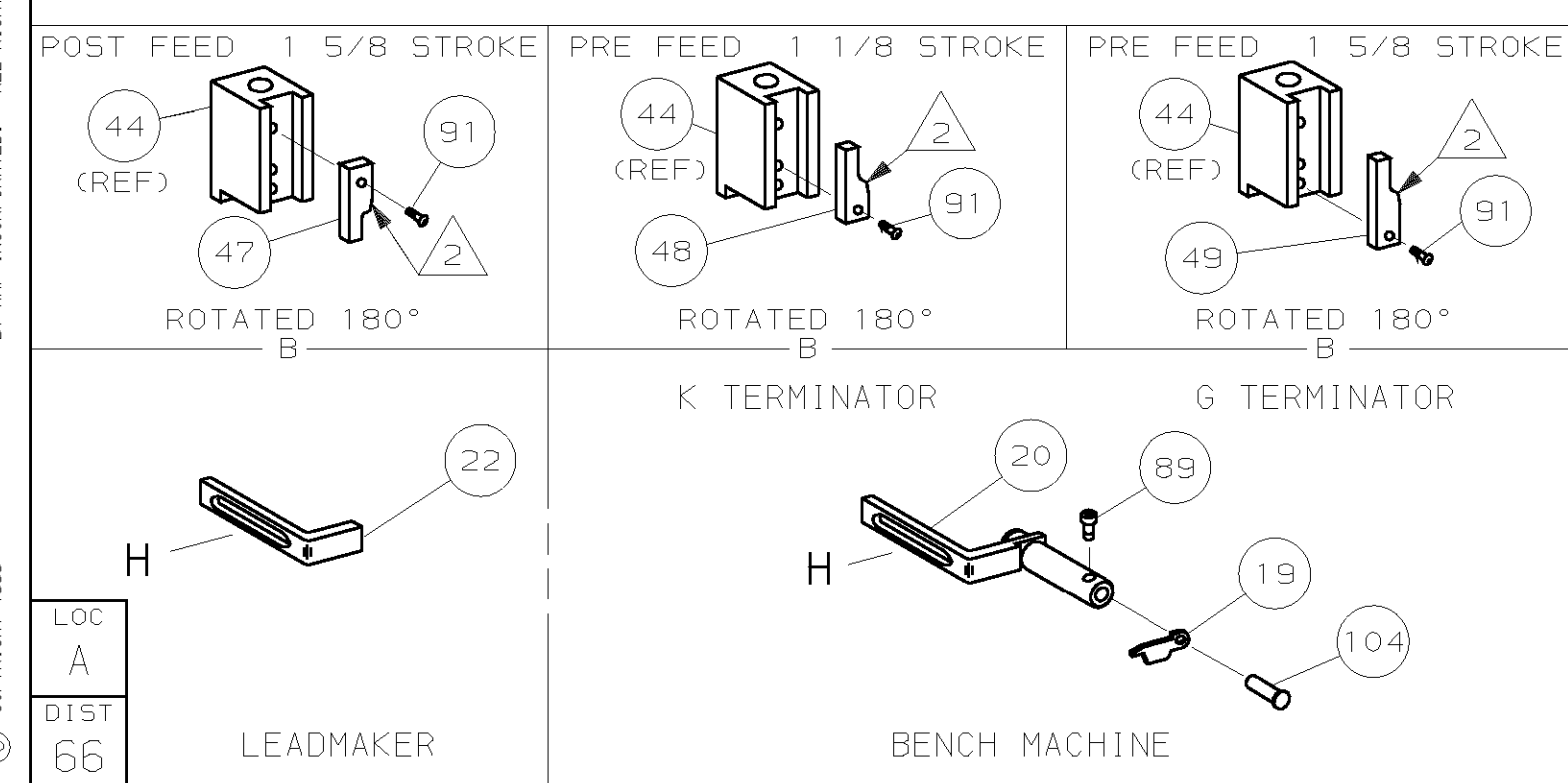
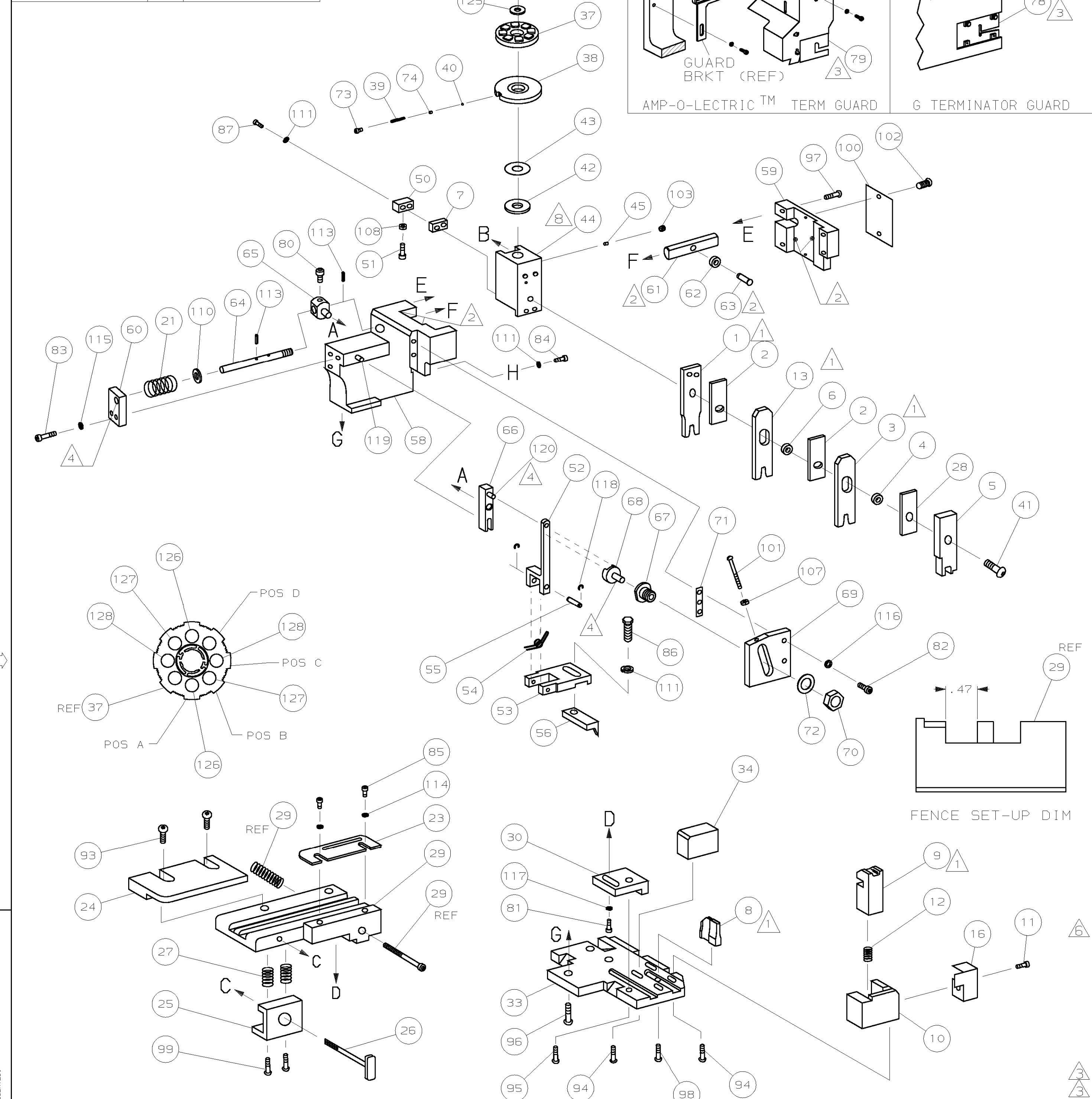

- 1 RECOMMENDED SPARE PARTS.
- 2 GREASE LIGHTLY.
- 3 GUARD MUST BE IN PLACE WHEN OPERATING APPLICATOR IN A BENCH MACHINE.
- 4 LUBRICATE DAILY USING NO. 20 MACHINE OIL.
- 5. ITEMS WITH QTY OF REF SPECIFIED (EXCEPT ITEMS 78 AND 79) ARE USED ON ITEM 46.
- 6 CUT TO LENGTH AT ASSY
- 7 GUIDE OFF STABILIZER BARREL.
- 8 PRESS SPRING PIN INTO RAM, FLUSH WITH WIRE CRIMPER, AT ASSEMBLY.

TERMINAL NAME: .140 Ø SOCKET		CRIMP DATA (AMP TERMINAL)	
PAD LTR	CRIMP HEIGHT	WIRE SIZE	
A	.073 ±.002 [1.86 ±0.05mm]	2.5 mm <sup>2</sup>	
B	.068 ±.002 [1.72 ±0.05mm]	2 mm <sup>2</sup>	
C	.062 ±.002 [1.58 ±0.05mm]	1.5 mm <sup>2</sup>	
D	NOT	USED	
CRIMP	SIZE	TYPE	RANGE
WIRE	.110 [2.79mm]	F	1.5mm-2.5mm
INSUL	.155 [3.94mm]	F	2.7mm-3.7mm

QTY	REF	REF	REF	REF	REF	DESCRIPTION	ITEM NO
2	2	2	-	C	1-354779-0	PIN, WIRE DISC (.3040)C	129
2	2	2	-	C	9-354778-5	PIN, WIRE DISC (.2970)B	127
2	2	2	-	C	8-354778-7	PIN, WIRE DISC (.2930)A	126
1	1	1	-	A	986950-1	WASHER, FLAT PRECISION	125
1	1	1	-	A	217238-1	GENERAL INSTRUCTION PACKAGE	124
1	1	1	-	-	4088040	SF APPL INST 408-8040	123
REF	REF	REF	-	A	1-21030-1	PIN, DOWEL (Ø.187x.50)LEVER	120
REF	REF	REF	-	A	1-21030-6	PIN, DOWEL (Ø.187x1.25)HOUSING	119
REF	REF	REF	-	A	21045-3	RING, RET "C" (Ø.187)FD FING PIN	118
1	1	1	-	A	21024-5	WASHER, LOCK (#10)ADJ BLOCK	117
REF	REF	REF	-	A	21024-5	WASHER, LOCK (#10)ADJ PLATE	116
REF	REF	REF	-	A	21024-5	WASHER, LOCK (#10)FEED GDE ROD	115
2	2	2	-	A	21024-2	WASHER, LOCK (#4)FRONT STP GUIDE	114
REF	REF	REF	-	A	5-21028-1	PIN, SLT 5PR (Ø.125x.50)ADJ ROD	113
4	4	4	-	A	21024-4	WASHER, LOCK (#8)STRIPPER	111
REF	REF	REF	-	A	21899-4	WASHER, FLAT (Ø5/16)SCREW ADJ	110
1	1	1	-	A	21018-5	NUT, HEX (NO. 6)HOLDDOWN	108
REF	REF	REF	-	A	21068-5	NUT, HEX (6-32)FEED ADJ	107
1	1	1	-	A	992031-1	PIN, CLEVIS	104
1	1	1	-	A	21009-2	SCR, 5KT SET (1/4-20x.25 LW)RAM	103
2	2	2	-	A	21017-2	SCR, DRIVE (#2x.19)ID PLATE	102
REF	REF	REF	-	A	6-23715-5	SCR, PAN HD (6-32x1.50)FEED ADJ	101
1	1	1	-	B	461264-1	PLATE, IDENTIFICATION	100
2	2	2	-	A	3-21002-0	SCR, BHC (10-32x.88)DRAG	99
1	1	1	-	A	22733-8	SCR, BHC (8-32x.38 LW)ANVIL	98
REF	REF	REF	-	A	2-21002-9	SCR, BHC (10-32x.75)CAP	97
REF	REF	REF	-	A	2-22733-8	SCR, BHC (1/4-20x.62)HOUSING	96
REF	REF	REF	-	A	2-21002-7	SCR, BHC (10-32x.50)5G ADJ BLOCK	95
4	4	4	-	A	2-21002-2	SCR, BHC (8-32x.50)TERM H DWN	94
2	2	2	-	A	2-21002-3	SCR, BHC (8-32x.62)R STP GDE	93
1	1	1	-	A	1-21002-7	SCR, BHC (6-32x.38)CAM	91
1	1	1	-	A	7-21000-9	SCR, SHC (4-40x.19)STRIPPER	89
2	2	2	-	A	2-21000-8	SCR, SHC (8-32x.54)DEP-HOLD	87
1	1	1	-	A	2-22603-0	SCR, HEX HD (8-32x.31)FEED FINGER	86
2	2	2	-	A	1-21000-3	SCR, SHC (4-40x.25)F ST GUIDE	85
1	1	1	-	A	2-21000-7	SCR, SHC (8-32x.50)STRIPPER	84
REF	REF	REF	-	A	3-21000-7	SCR, SHC (10-32x.75)FEED ROD 6D	83
REF	REF	REF	-	A	3-21000-6	SCR, SHC (10-32x.62)FD ADJ BLK	82
1	1	1	-	A	3-21000-4	SCR, SHC (10-32x.38)5G ADJ BL	81
REF	REF	REF	-	A	3-21000-4	SCR, SHC (10-32x.38)PIVOT BLK	80
-	REF	-	-	B	455749-1	GUARD, WINDOW	79
REF	-	-	-	B	679532-1	INSERT, GUARD	78
-3	-2	-1	U/M	DWG SIZE	PART NO	DESCRIPTION	ITEM NO

QTY	REF	REF	REF	REF	REF	DESCRIPTION	ITEM NO
-1						LEADMAKER	
-2						BENCH MODEL K	
-3						BENCH MODEL G	
REF	REF	REF	-	B	22594-8	NUT, HEX (1/2-20)	70
REF	REF	REF	-	B	240628-1	PLATE, ADJUSTMENT	69
REF	REF	REF	-	B	240626-1	SHAFT, PIVOT	68
REF	REF	REF	-	B	240633-1	BUSHING	67
REF	REF	REF	-	A	455680-1	LEVER, INTERMEDIATE	66
REF	REF	REF	-	B	240629-1	BLOCK, PIVOT	65
REF	REF	REF	-	A	240632-2	SCREW, ADJ FEED ROD	64
REF	REF	REF	-	B	240659-3	PIN, CAM ROLLER	63
REF	REF	REF	-	B	240658-1	ROLLER, CAM	62
REF	REF	REF	-	B	454398-2	ROD, FEED	61
REF	REF	REF	-	A	454178-1	GUIDE, FEED ROD	60
REF	REF	REF	-	C	454220-1	CAP, RAM	59
REF	REF	REF	-	D	454485-1	HOUSING	58
1	1	1	-	B	1-694433-6	PAWL, FEED	56
REF	REF	REF	-	B	240624-1	PIN, FEED FINGER	55
REF	REF	REF	-	B	691499-1	SPRING, FEED FINGER	54
REF	REF	REF	-	B	690541-1	HOLDER, FEED FINGER	53
REF	REF	REF	-	A	455679-2	LEVER, TERMINAL FEED ARM	52
1	1	1	-	A	811242-2	BUMPER, HOLDDOWN	51
1	1	1	-	A	690753-1	SPACER, TONKER	50
1	-	-	-	B	690602-6	CAM, PRE-FEED 1 5/8 ST	49
-	1	-	-	B	690602-5	CAM, PRE-FEED 1 1/8 ST	48
-	-	1	-	B	690501-4	CAM, POST-FEED 1 5/8 ST	47
1	1	1	-	B	459456-2	APPLICATOR, BASIC (SUBASSY)	46
1	1	1	-	A	690191-1	PLUG, NYLON	45
1	1	1	-	C	819307-4	RAM	44
1	1	1	-	A	690125-1	WASHER, LAMINATED	43
1	1	1	-	A	690124-1	WASHER, RAM	42
1	1	1	-	A	690686-2	BOLT, CRIMPER (5/16x1.00)	41
1	1	1	-	A	23241-6	BALL, STEEL	40
1	1	1	-	A	690170-1	SPRING, COMPRESSION	39
1	1	1	-	C	1-690142-0	DISC, INSULATION	38
1	1	1	-	D	354777-1	WIRE DISC, PLASTIC	37
1	1	1	-	A	22480-5	WASHER, SPRING	36
1	1	1	-	B	690212-1	POST, RAM	35
1	1	1	-	B	690786-1	SUPPORT, TERMINAL	34
REF	REF	REF	-	D	455675-1	PLATE, BASE	33
REF	REF	REF	-	B	455689-1	BLOCK, STRIP GUIDE ADJ	30
1	1	1	-	C	318756-1	STRIP GUIDE PLATE ASSY	29
1	1	1	-	C	1-455888-5	SPACER, FRONT SHEAR DEP	28
2	2	2	-	A	1-22284-0	SPRING, DRAG	27
1	1	1	-	B	690546-1	LEVER, DRAG RELEASE	26
1	1	1	-	B	240792-1	DRAG, TERMINAL	25
1	1	1	-	D	9-690504-4	GUIDE, STRIP (REAR)	24
1	1	1	-	A	690438-1	GUIDE, STRIP (FRONT)	23
-	-	1	-	B	690472-2	STRIPPER	22
REF	REF	REF	-	A	4-22284-9	SPRING, FEED RETURN	21
1	1	1	-	A	679218-1	STRIPPER WIRE STOP ASSY	20
1	1	1	-	B	458949-1	STRIPPER	19
1	1	1	-	B	318563-1	GUARD, CHIP, FRONT	16
1	1	1	-	C	9-456135-4	CRIMPER, STABILIZER	13
1	1	1	-	A	5-22280-0	SPRING, SHEAR	12
1	1	1	-	B	690461-1	STOP, SHEAR	11
1	1	1	-	C	690459-1	HOLDER, SHEAR (FRONT)	10
1	1	1	-	C	454276-1	SHEAR, FLOAT (FRONT)	9
1	1	1	-	C	1213557-2	ANVIL	8
1	1	1	-	C	6-240641-4	SPACER, DEPRESSOR (REAR)	7
1	1	1	-	B	238011-2	SPACER, BLOCK CRIMPER	6
1	1	1	-	C	1-455889-4	DEPRESSOR, SHEAR (FRONT)	5
1	1	1	-	B	2-238011-2	SPACER, BLOCK CRIMPER	4
1	1	1	-	C	683453-3	CRIMPER, INSULATION	3
2	2	2	-	C	455888-4	SPACER, CRIMPER	2
1	1	1	-	C	456408-8	CRIMPER, WIRE	1

QTY	REF	REF	REF	REF	REF	DESCRIPTION	ITEM NO
-3	-2	-1	U/M	DWG SIZE	PART NO	DESCRIPTION	ITEM NO

THIS DRAWING IS A CONTROLLED DOCUMENT.

RELEASING FOR PUBLICATION MAR 08, 1999 BY AMP INCORPORATED. ALL RIGHTS RESERVED.

THIS DRAWING IS UNCLASSIFIED. DATE 03-08-1999 BY AMP INCORPORATED. ALL RIGHTS RESERVED.

DIMENSIONS IN INCHES. DO NOT SCALE PRINT. TOLERANCES UNLESS OTHERWISE SPECIFIED:  
 2 PLC DEC ±.02  
 3 PLC DEC ±.02  
 4 PLC DEC ±.02  
 ANGLES ± - SURF TEXTURE: ✓  
 REMOVE BURRS, BREAK SHARP EDGES R.015 MAX

MATL - HT TR - FIN -  
 DR B.HIGMAN 090CT98 APP 090CT98 T.ELBIN  
 CHK 090CT98 REL - C.ERISMAN  
**AMP** AMP Incorporated Harrisburg, PA 17105-3608  
 NAME: SIDE FEED HDM APPLICATOR MACHINE REF: MINI APPL  
 SCALE: D DWG NO: 680709 SHEET: 1 OF 1 REV: B  
 CASE CODE: 00779 CUSTOMER AND ASSEMBLY DRAWING RESTRICTED TO