

COVER ASSEMBLY		CAVITY BLOCK		
PART NO.	COLOR	PART NO.	COLOR	KEY
1326144-1	Black	1241494-1	Red	A (Left)
		1241495-1	Green	B (Right)
1326144-2	Gray	1241494-2	Blue	B (Left)
		1241495-2	Gray	A (Right)

Figure 1

1. INTRODUCTION

This instruction sheet provides assembly procedures for the 56-Position IBCM connector shown in Figure 1.



All dimensions are in millimeters [with inches in brackets]. Figures and illustrations are for reference only and are not drawn to scale.

2. DESCRIPTION

Two types of socket contacts are installed in the 28-position cavity block. Two cavity blocks are installed in the cover assembly. The cavity blocks and cover assembly are color coded and keyed for

identification and proper assembly. Two cover assemblies are installed in the 112-position tab header.

3. CONTACT TERMINATION, INSERTION, AND EXTRACTION

Refer to the instructions packaged with the socket contacts and crimp tooling for proper wire size, strip dimensions, and crimping procedures.

To insert contacts:

- Align contact retention lance with outside of selected cavity in the cavity block. Contacts are polarized for correct orientation. See Figure 2.
- Push contact straight into cavity block until the retention lance snaps into place.

To extract contacts:

- Depress the contact retention lance and simultaneously pull the contact straight out of the cavity.

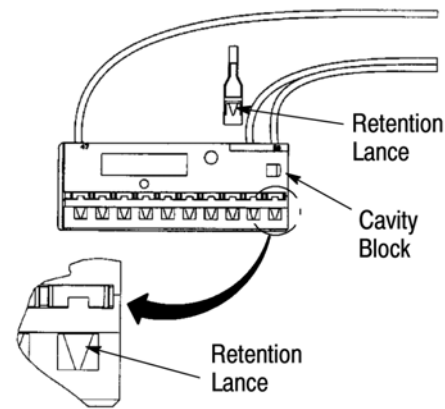

Figure 2

4. CAVITY BLOCK INSTALLATION AND REMOVAL

4.1. Installation of Cavity Blocks

Refer to the chart in Figure 1 for color coding and key orientation of the cavity blocks and cover assembly. Insert each cavity block as follows:

1. Bend all wires at approximately 90° in the opposite direction of the arrow on the side of the cavity block. See Figure 3.
2. Align each cavity block with appropriate side of cover assembly. Push block straight into cover until the latch snaps into place.
3. Attach wires to strain relief support with cable tie or equivalent.

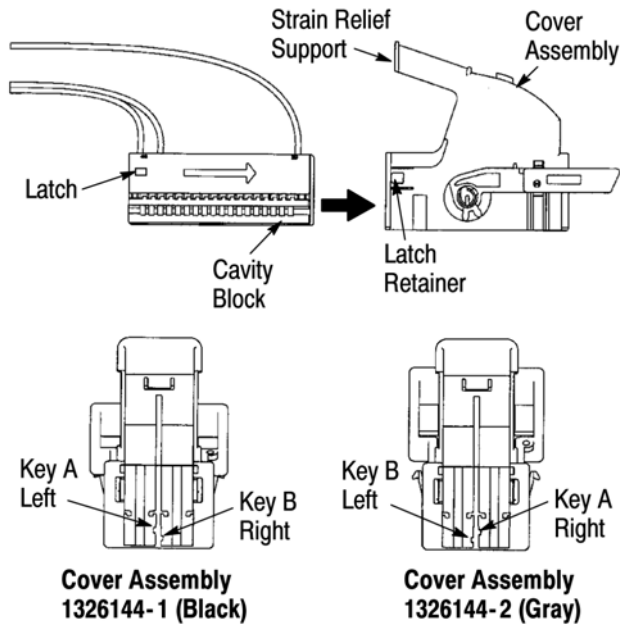

Figure 3

#### 4.2. Removal of Cavity Blocks

1. Detach wires from strain relief support.
2. Release latch retainer on side of cover assembly and simultaneously pull cavity block from cover assembly. See Figure 4.

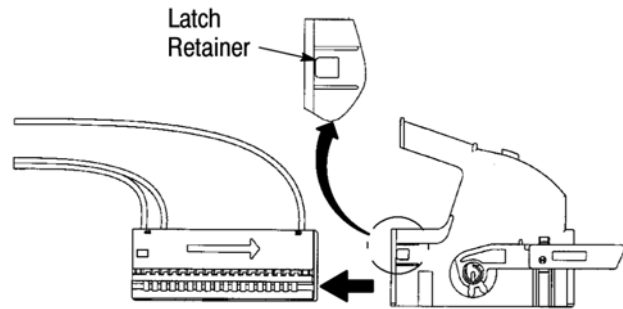

Figure 4

### 5. MATING AND UNMATING CONNECTOR

#### 5.1. Mating Connector with Tab Header

The lever must be in the horizontal or mating position before placing the connector on the tab header (see Figure 5).

1. Align the connector with the header and push the connector straight down on the header. The lever will partially move upward or rotate away from the header and click into the pre-lock position.

2. Pull the lever up or away from the header until the lever snaps over the lever lock and into the locked position.

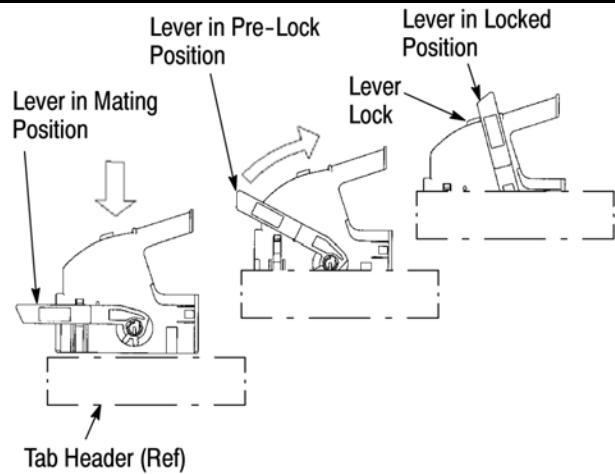

Figure 5

#### 5.2. Unmating Connector from Tab Header

1. Depress the lever lock. See Figure 6.
2. Push the lever downward until the lever snaps into the horizontal position. The connector is now fully unmated.

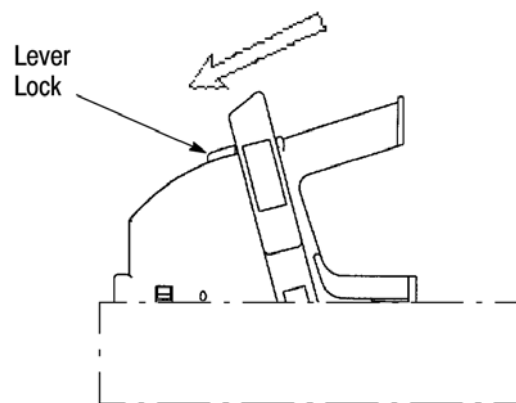

Figure 6

### 6. REVISION SUMMARY

- New logo