



# AK4136

## 32bit 384kHz SRC

### 1. General Description

The AK4136 is a 2ch digital sample rate converter (SRC). The input sample rate ranges from 8kHz to 384kHz. The output sample rate is from 8kHz to 384kHz. The AK4136 has an internal Oscillator. Therefore it does not need any external master clocks and simplifies system configuration. The AK4136 is suitable for a high-resolution audio application interfacing to different sample rates such as Network Audios, USB DACs and Car Audios.

Application: AV Receivers, CD/SACD Players, Network Audios, USB DACs, USB Headphones, Sound Plate/Bars, Car Audios, Automotive External Amplifiers, Measuring Instruments, Control Systems, Public Audios (PA), IC-Recorders, Bluetooth Headphones, HD Audio/Voice Conference Systems

### 2. Features

- 2 channels input/output
- Asynchronous Sample Rate Converter
- PCM
  - Input Sample Rate Range (FSI): 8kHz ~ 384kHz
  - Output Sample Rate Range (FSO): 8kHz ~ 384kHz
- Input to Output Sample Rate Ratio: FSO/FSI = 1/6 ~ 12
- THD+N: Up to -140dB
- Dynamic Range: 176dB (A-weighted)
- I/F format: MSB justified, LSB justified, I2S compatible and TDM
- Oscillator for Internal Operation Clock
- Clock for Master mode: 128/192/256/384/512/768fso
- On-chip X'tal oscillator
- Digital De-emphasis Filter (32kHz, 44.1kHz, 48kHz) (Serial Mode Only)
- Soft Mute Function
- SRC Bypass mode (Master/Slave, PCM)
- uP Interface : I2C bus/SPI 4-wire
- Power Supply
  - DVDD: 3.0~3.6V (internal LDO enabled)
  - DVDD: 1.7~1.9V (internal LDO disabled)
- Ta: -40 ~ +105°C
- Package: 48-pin LQFP (0.5mm pitch)

<b>3. Table of Contents</b>
-----------------------------

1.	General Description .....	1
2.	Features .....	1
3.	Table of Contents .....	2
4.	Block Diagram .....	4
5.	Pin Configurations and Functions .....	5
	■ Pin Configurations .....	5
	■ Pin Functions .....	6
6.	Absolute Maximum Ratings .....	9
7.	Recommended Operation Conditions .....	9
8.	SRC Characteristics .....	10
	■ PCMIN → PCMOUT .....	10
9.	Power Consumptions .....	11
	■ Internal LDO Mode .....	11
	■ DV18 External Supply Mode .....	11
10.	Filter Characteristics .....	12
	■ Sharp Roll-Off Filter Characteristics .....	12
	■ Slow Roll-Off Filter Characteristics .....	13
	■ Short Delay Sharp Roll-Off Filter Characteristics .....	14
	■ Short Delay Slow Roll-Off Filter Characteristics .....	15
11.	Input and Output Examples .....	15
12.	DC Characteristics .....	16
13.	Switching Characteristics .....	16
	■ Timing Diagrams .....	22
14.	Functional Descriptions .....	29
	■ Power-up Sequence .....	29
	■ SRC Bypass Mode .....	30
	■ System Clock and Audio Interface Format for Input PORT .....	32
	■ System Clock for Output PORT .....	36
	■ Audio Interface Format for Output PORT .....	38
	■ Cascade Connection in TDM Mode .....	43
	■ Soft Mute Function .....	44
	■ Dither Circuit .....	45
	■ Digital Filter .....	46
	■ De-emphasis Filter .....	46
	■ Regulator .....	46
	■ System Reset .....	47
	■ Internal Reset Function for Clock Change .....	48
	■ When the Frequency of ILRCK at Input Port Is Changed Without A Reset by The PDN Pin or RSTN Bit .....	50
	■ When the Frequency of OLRCK at Output Port Is Changed Without A Reset by The PDN Pin or RSTN Bit .....	50
	■ Pop Noise Reduction in Sampling Rate Conversion .....	50
	■ Internal Status Pin .....	51
	■ Serial Control Interface .....	52
	■ Register Map .....	56
	■ Register Definitions .....	57
15.	Jitter Tolerance .....	60
16.	Recommended External Circuit .....	61
17.	Package .....	63
	■ Outline Dimensions .....	63
	■ Material & Lead Finish .....	63
	■ Marking .....	64
18.	Ordering Guide .....	64
19.	Revision History .....	65
	<b>IMPORTANT NOTICE</b> .....	66

	AK4137	AK4136
bit	32	←
DR (A-Weighted)	186	176
THD+N	150	140
fsi	8 ~ 768kHz	8 ~ 384kHz
fso	8 ~ 768kHz	8 ~ 384kHz
Ratio I/O	1/6 ~ 24	1/6 ~ 12
Output Clock (Master Mode Operation)	64/128/256/384/512/768fso	128/256/384/512/768fso
SRC Conversion	PCM → PCM, DSD → DSD DSD → PCM, PCM → DSD DoP → DSD, DoP → PCM	PCM → PCM conversion only
SRC Bypass Function	Available (Master, Slave)	←
Soft Mute	Available Semi-Auto Mode Mute Time Setting Adjustment	Available Semi-Auto Mode and Mute Time Adjustment are only available by register settings.
DITHER	Available	Available (only by register settings)
De-emphasis	Available	Available (only by register settings)
Internal Regulator	3V→1.8V	←
External 1.8V Input	Available	←
Crystal Oscillator	Available	←
Pop Noise reduction on Rate Switching	Available	←
Micro Controller I/F	I2C, 4-wire	←

4. Block Diagram

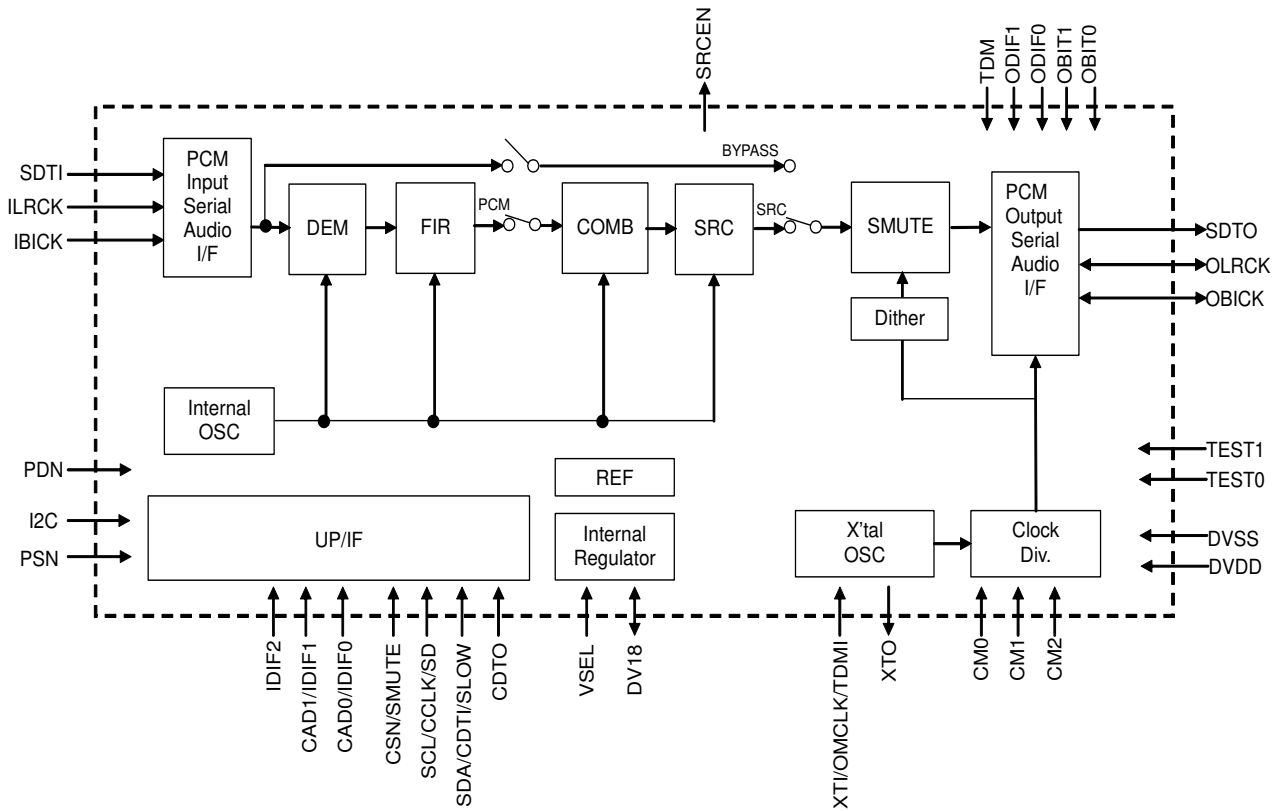

Figure 1. Block Diagram

**5. Pin Configurations and Functions**

■ Pin Configurations

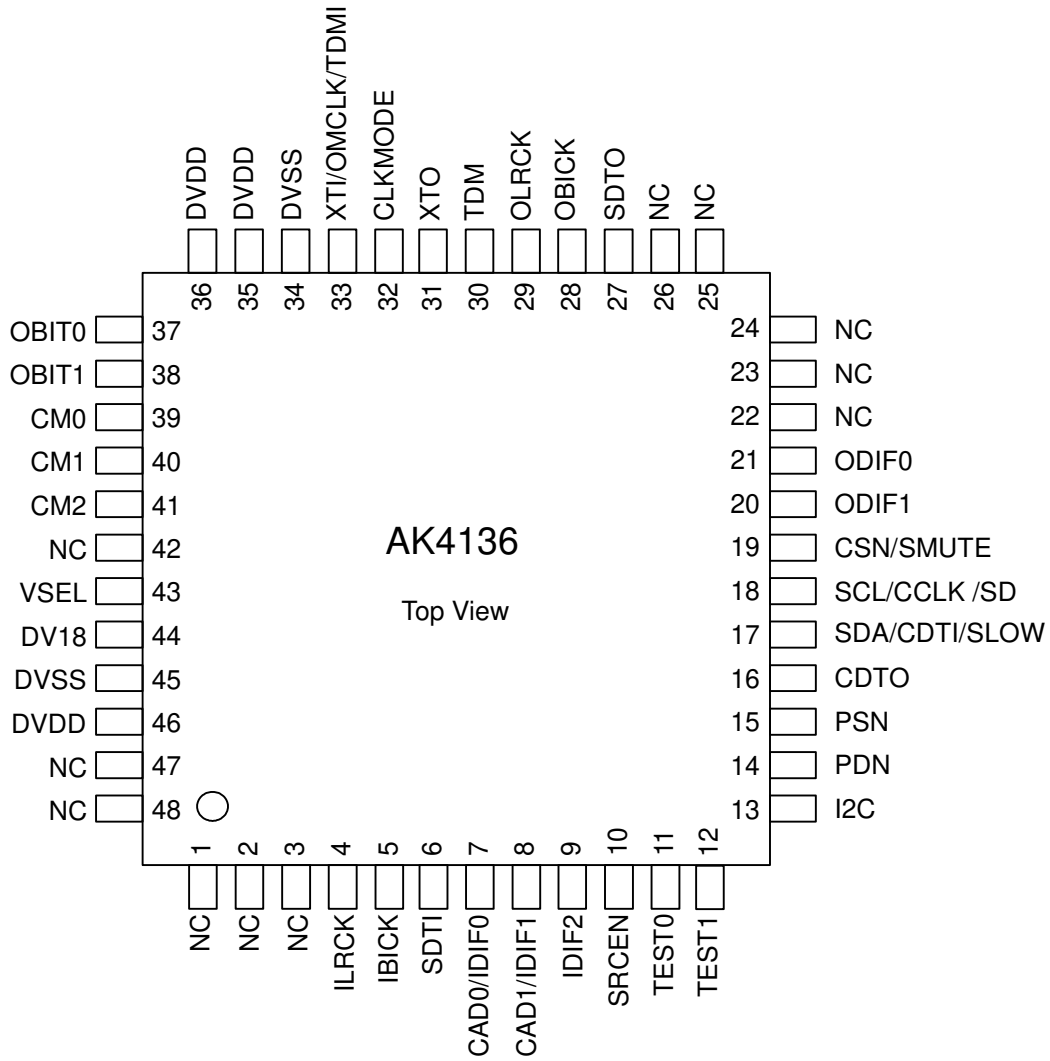

Figure 2. Pin Layout

## ■ Pin Functions

No.	Pin Name	I/O	Function
1	NC	-	This pin must be connected to DVSS.
2	NC	-	This pin must be connected to DVSS.
3	NC	-	This pin must be connected to DVSS.
4	ILRCK	I	L/R Clock Pin in PCM Mode
5	IBICK	I	Audio Serial Data Clock Pin in PCM Mode
6	SDTI	I	Audio Serial Data Input Pin in PCM Mode
7	CAD0	I	Chip Address 0 Pin in Serial Control Mode
	IDIF0	I	Digital Input Format 0 Pin in Parallel Control Mode
8	CAD1	I	Chip Address 1 Pin in Serial Control Mode
	IDIF1	I	Digital Input Format 1 Pin in Parallel Control Mode
9	IDIF2	I	Digital Input Format 2 Pin in Parallel Control Mode
10	SRCEN	O	Unlock Status Pin When the PDN pin= "L", this pin outputs "H".
11	TEST0	I	Test pin 0. Must be connected to DVSS in normal use.
12	TEST1	I	Test pin 1. Must be connected to DVSS in normal use.
13	I2C	I	Select serial mode "L": 4-wire serial Mode , "H": I2C Mode
14	PDN	I	Power-Down Mode Pin "H": Power up, "L": Power down reset and initializes the control register. The AK4136 should be reset once by bringing PDN pin = "L" upon power-up.
15	PSN	I	Parallel/Serial Mode Select "L": Serial Mode , "H": Parallel Mode
16	CDTO	O	I2C= "L": Control Data Output Pin in Serial Control Mode
17	SDA	I/O	I2C= "H": Control Data In/Out Pin in Serial Control Mode
	CDTI	I	I2C= "L": Control Data Input Pin in Serial Control Mode
	SLOW	I	Digital Filter Select Pin in Parallel Control Mode
18	SCL	I	I2C= "H": Control Data Clock Input Pin in Serial Control Mode
	CCLK	I	I2C= "L": Control Data Clock Pin in Serial Control Mode
	SD	I	Digital Filter Select Pin in Parallel Control Mode
19	CSN	I	Chip Select Pin in Serial Control Mode, I2C= "L"
	SMUTE	I	Soft Mute Pin in Parallel Control Mode When this pin is changed to "H", soft mute cycle is initiated. When returning "L", the output mute releases.
20	ODIF1	I	Audio Interface Format #1 Pin for Output PORT
21	ODIF0	I	Audio Interface Format #0 Pin for Output PORT
22	NC	-	This pin must be connected to DVSS.
23	NC	-	This pin must be connected to DVSS.
24	NC	-	This pin must be connected to DVSS.
25	NC	-	This pin must be connected to DVSS.
26	NC	-	This pin must be connected to DVSS.

Note 1. All input pins must not be allowed to float. DVDD must be connected to the same power supply.

Note 2. PSN, CM2-0, OBIT1-0, TDM, ODIF1-0, IDIF2-0 and CAD1-0 pins must be changed when the PDN pin = "L".

No.	Pin Name	I/O	Function
27	SDTO	O	Audio Serial Data Output Pin for Output PORT When the PDN pin = "L", the SDTO pin outputs "L".
28	OBICK	I/O	Audio Serial Data Clock Pin for Output PORT When the PDN pin = "L" in master mode, the OBICK pin outputs "L".
29	OLRCK	I/O	Output Channel Clock Pin for Output PORT When the PDN pin = "L" in master mode, the OLRCK pin outputs "L".
30	TDM	I	TDM Format Select Pin "L"(connected to DVSS): Stereo Mode "H"(connected to DVDD): TDM mode for Output
31	XTO	O	X'tal Output Pin When the PDN pin = "L" or CM2-0 pins = "HHL" or "HHH", XTO outputs "L".
32	CLKMODE	I	Master Clock Select Pin "L"(connected to DVSS): X'tal Mode "H"(connected to DVDD): External Master Clock or TDM pin = "H"
33	XTI	I	X'tal Input Pin
	OMCLK	I	External Master Clock Input
	TDMI	I	TDMI Daisy-Chain Input Pin
34	DVSS	-	Digital Ground Pin
35	DVDD	-	Digital Power Supply Pin, 3.0 ~ 3.6V or 1.7 ~ 1.9V
36	DVDD	-	Digital Power Supply Pin, 3.0 ~ 3.6V or 1.7 ~ 1.9V
37	OBIT0	I	Bit Length Select #0 Pin for Output Data
38	OBIT1	I	Bit Length Select #1 Pin for Output Data
39	CM0	I	Clock Select or Mode Select #0 Pin for Output PORT
40	CM1	I	Clock Select or Mode Select #1 Pin for Output PORT
41	CM2	I	Clock Select or Mode Select #2 Pin for Output PORT
42	NC	-	This pin must be connected to DVSS.
43	VSEL	I	Digital Power select "L": DV18 is Output pin, "H": DV18 is Power Supply Pin
44	DV18	I/O	Digital Power Pin, Typ 1.8V VSEL= "L", Output When the PDN pin= "L", the DV18 pin outputs "L". Current must not be taken from this pin. A 10 $\mu$ F ( $\pm$ 30%; including the temperature characteristics) capacitor should be connected between this pin and DVSS. When this capacitor is polarized, the positive polarity pin should be connected to the DV18 pin. VSEL= "H", Input
45	DVSS	-	Digital Ground Pin
46	DVDD	-	Digital Power Supply Pin, 3.0 ~ 3.6V or 1.7 ~ 1.9V
47	NC	-	This pin must be connected to DVSS.
48	NC	-	This pin must be connected to DVSS.

Note 1. All input pins must not be allowed to float. DVDD must be connected to the same power supply.

Note 2. PSN, CM2-0, OBIT1-0, TDM, ODIF1-0, IDIF2-0 and CAD1-0 pins must be changed when the PDN pin = "L".

## \*Unused Input/Output Pins

Classification	Pin Name	Setting
Digital	CSN/SMUTE	Connect to DVSS
	XTI/OMCLK/TDMI	Connect to DVSS (Slave Mode)
	SRCEN, XTO, CDTO	Open

\* The status of OLRCK and OBICK pins, when the PDN pin = "L", are shown below. ("L" output in Master mode)

Setting Pins			OLRCK, OBICK
CM2	CM1	CM0	
L	L	L	"L" Output
L	L	H	
L	H	L	
L	H	H	
H	L	L	Input
H	L	H	"L" Output
H	H	L	
H	H	H	

\* The output pin status when the PDN pin = "L" is shown below.

Output Pin	Status
SDTO	"L" Output
SRCEN	"H" Output
XTO	"L" Output
CDTO	Hi-z



### 6. Absolute Maximum Ratings

(DVSS=0V; [Note 3](#))

Parameter		Symbol	Min.	Max.	Unit
Power Supplies	Digital	DVDD	-0.3	4.3	V
	(Internal Digital) ( <a href="#">Note 4</a> )	DV18	-0.3	2.5	V
Input Current, Any Pin Except Supplies		IIN	-	±10	mA
Digital Input Voltage ( <a href="#">Note 5</a> )		VDIN	-0.3	(DVDD+0.3) or 4.3	V
Ambient Temperature (Power applied) ( <a href="#">Note 6</a> )		Ta	-40	105	°C
Storage Temperature		Tstg	-65	150	°C

Note 3. All voltages are with respect to ground.

Note 4. DVSS must be connected to the same ground.

Note 5. ILRCK, IBICK, SDTI, IDIF0/CAD0, IDIF1/CAD1, IDIF2, PDN, PSN, I2C, SLOW/CDTI/SDA, SD/CCLK/SCL, SMUTE/CSN, OBIT1-0, ODIF1-0, CM2-0, VSEL, TEST1-0 pin. Regarding Digital Input pins, maximum value which is lower value (DVDD + 0.3) or 4.3 V.

Note 6. In the case that the PCB wiring density is more than 100%

WARNING: Operation at or beyond these limits may result in permanent damage to the device.  
Normal operation is not guaranteed at these extremes.

### 7. Recommended Operation Conditions

(DVSS=0V; [Note 3](#); VSEL= "L")

Parameter		Symbol	Min.	Typ.	Max.	Unit
Power Supplies	Digital	DVDD	3.0	3.3	3.6	V

(DVSS=0V; [Note 3](#); VSEL= "H")

Parameter		Symbol	Min.	Typ.	Max.	Unit
Power Supplies: ( <a href="#">Note 7</a> )	Digital	DVDD	1.7	1.8	1.9	V
	Digital	DV18	1.7	1.8	1.9	V
Difference		DVDD- DV18	-	0	-	V

Note 3. All voltages are with respect to ground.

Note 7. DVDD and DV18 should be connected externally.

The PDN pin must be "L" when power up the AK4136. Set the PDN pin to "H" after all power supplies are ON. Writing by a microcontroller should be executed with a 5ms interval after the PDN pin = "H".

<b>8. SRC Characteristics</b>
-------------------------------

■ PCMIN → PCMOUT

(Ta=-40~ +105°C; DVDD=3.0~3.6V or DVDD=DV18=1.7V~1.9V; DVSS=0V; Signal Frequency = 1kHz; data = 32bit; measurement bandwidth = 20Hz~FSO/2; unless otherwise specified.)

Parameter	Symbol	Min.	Typ.	Max.	Unit
Resolution				32	Bits
Input Sample Rate	FSI	8		384	kHz
Output Sample Rate	FSO	8		384	kHz
THD+N (Input = 1kHz, 0dBFS)					
FSO/FSI = 48kHz/48kHz		-	-140	-	dB
FSO/FSI = 48kHz/44.1kHz		-	-133	-	dB
FSO/FSI = 48kHz/192kHz		-	-143	-	dB
FSO/FSI = 192kHz/48kHz		-	-134	-	dB
Worst Case (FSO/FSI=32kHz/176.4kHz)		-	-	-100	dB
Dynamic Range (Input = 1kHz, -60dBFS)					
FSO/FSI = 48kHz/44.1kHz		-	170	-	dB
FSO/FSI = 48kHz/192kHz		-	174	-	dB
FSO/FSI = 192kHz/48kHz		-	170	-	dB
FSO/FSI = 32kHz/176.4kHz		-	170	-	dB
Worst Case (FSO/FSI = 48kHz/48kHz)		168	-	-	dB
Dynamic Range (Input = 1kHz, -60dBFS, A-weighted)					
FSO/FSI = 8kHz/48kHz		-	176	-	dB
Ratio between Input and Output Sample Rate	FSO/FSI	1/6		12	-

<b>9. Power Consumptions</b>
------------------------------

■ **Internal LDO Mode**

(Ta=-40~ +105°C; DVDD=3.0~3.6V)

Parameter	Symbol	Min.	Typ.	Max.	Unit
Power Supply Current Normal operation: (PDN = "H") FSI=FSO=48kHz at Master Mode : DVDD=3.3V		-	11	-	mA
FSI=FSO=192kHz at Master Mode: DVDD=3.3V		-	33	-	mA
FSI=FSO=384kHz at Master Mode: DVDD=3.3V		-	40	-	mA
: DVDD=3.6V		-	-	60	mA
Power down: PDN pin = "L" (Note 8) DVDD=3.6V			10	100	μA

Note 8. All digital inputs including clock pins are held to DVSS.

■ **DV18 External Supply Mode**

(Ta=-40~ +105°C; DVDD=DV18=1.7~1.9V)

Parameter	Symbol	Min.	Typ.	Max.	Unit
Power Supply Current Normal operation:					
FSI=FSO=48kHz at Master Mode : DVDD=DV18=1.8V		-	11	-	mA
FSI=FSO=192kHz at Master Mode: DVDD=DV18=1.8V		-	28	-	mA
FSI=FSO=384kHz at Master Mode: DVDD=DV18=1.8V		-	32	-	mA
: DVDD=DV18=1.9V		-	-	50	mA
Power down: PDN pin = "L" (Note 8) DVDD=DV18=1.9V			10	100	μA

Note 8. All digital inputs including clock pins are held to DVSS.

<b>10. Filter Characteristics</b>
-----------------------------------

■ Sharp Roll-Off Filter Characteristics

(Ta=-40~ +105°C; DVDD=3.0~3.6V or DVDD=DV18=1.7V~1.9V, DVSS=0V)

Parameter	Symbol	Min.	Typ.	Max.	Unit	
<b>Digital Filter</b>						
Passband -0.01dB	$0.985 \leq \text{FSO/FSI} \leq 12.000$	PB	0	-	0.4583FSI	kHz
	$0.905 \leq \text{FSO/FSI} < 0.985$	PB	0	-	0.4167FSI	kHz
	$0.714 \leq \text{FSO/FSI} < 0.905$	PB	0	-	0.3195FSI	kHz
	$0.656 \leq \text{FSO/FSI} < 0.714$	PB	0	-	0.2852FSI	kHz
	$0.536 \leq \text{FSO/FSI} < 0.656$	PB	0	-	0.2182FSI	kHz
	$0.492 \leq \text{FSO/FSI} < 0.536$	PB	0	-	0.2177FSI	kHz
	$0.452 \leq \text{FSO/FSI} < 0.492$	PB	0	-	0.1948FSI	kHz
	$0.357 \leq \text{FSO/FSI} < 0.452$	PB	0	-	0.1458FSI	kHz
	$0.324 \leq \text{FSO/FSI} < 0.357$	PB	0	-	0.1302FSI	kHz
	$0.246 \leq \text{FSO/FSI} < 0.324$	PB	0	-	0.0917FSI	kHz
	$0.226 \leq \text{FSO/FSI} < 0.246$	PB	0	-	0.0826FSI	kHz
	$0.1667 \leq \text{FSO/FSI} < 0.226$	PB	0	-	0.0583FSI	kHz
Stopband	$0.985 \leq \text{FSO/FSI} \leq 12.000$	SB	0.5417FSI	-	-	kHz
	$0.905 \leq \text{FSO/FSI} < 0.985$	SB	0.5021FSI	-	-	kHz
	$0.714 \leq \text{FSO/FSI} < 0.905$	SB	0.3965FSI	-	-	kHz
	$0.656 \leq \text{FSO/FSI} < 0.714$	SB	0.3643FSI	-	-	kHz
	$0.536 \leq \text{FSO/FSI} < 0.656$	SB	0.2974FSI	-	-	kHz
	$0.492 \leq \text{FSO/FSI} < 0.536$	SB	0.2813FSI	-	-	kHz
	$0.452 \leq \text{FSO/FSI} < 0.492$	SB	0.2604FSI	-	-	kHz
	$0.357 \leq \text{FSO/FSI} < 0.452$	SB	0.2116FSI	-	-	kHz
	$0.324 \leq \text{FSO/FSI} < 0.357$	SB	0.1969FSI	-	-	kHz
	$0.246 \leq \text{FSO/FSI} < 0.324$	SB	0.1573FSI	-	-	kHz
	$0.226 \leq \text{FSO/FSI} < 0.246$	SB	0.1471FSI	-	-	kHz
	$0.1667 \leq \text{FSO/FSI} < 0.226$	SB	0.1020FSI	-	-	kHz
Passband Ripple	$0.226 \leq \text{FSO/FSI} \leq 12.000$	PR	-	-	±0.01	dB
	$0.1667 \leq \text{FSO/FSI} < 0.226$	PR	-	-	±0.03	dB
Stopband Attenuation	$0.985 \leq \text{FSO/FSI} \leq 12.000$	SA	140.2	-	-	dB
	$0.905 \leq \text{FSO/FSI} < 0.985$	SA	140.9	-	-	dB
	$0.714 \leq \text{FSO/FSI} < 0.905$	SA	135.2	-	-	dB
	$0.656 \leq \text{FSO/FSI} < 0.714$	SA	135.1	-	-	dB
	$0.536 \leq \text{FSO/FSI} < 0.656$	SA	133.5	-	-	dB
	$0.492 \leq \text{FSO/FSI} < 0.536$	SA	115.3	-	-	dB
	$0.452 \leq \text{FSO/FSI} < 0.492$	SA	118.2	-	-	dB
	$0.357 \leq \text{FSO/FSI} < 0.452$	SA	123.3	-	-	dB
	$0.324 \leq \text{FSO/FSI} < 0.357$	SA	122.9	-	-	dB
	$0.246 \leq \text{FSO/FSI} < 0.324$	SA	117.9	-	-	dB
Group Delay (Note 9)	$0.226 \leq \text{FSO/FSI} \leq 12.000$	SA	119.7	-	-	dB
	$0.1667 \leq \text{FSO/FSI} < 0.226$	SA	90.3	-	-	dB
Group Delay (Note 9)		GD	-	64	-	1/fs

Note 9. This is the time from a rising edge of ILRCK after L and R channels data is input to a rising edge of OLRCK before the L and R channels data is output, when there is no phase difference between input and output data.

### ■ Slow Roll-Off Filter Characteristics

(Ta=-40~ +105°C; DVDD=3.0~3.6V or DVDD=DV18=1.7V~1.9V, DVSS=0V)

Parameter		Symbol	Min.	Typ.	Max.	Unit
<b>Digital Filter</b>						
Passband -0.01dB	$0.1667 \leq FSO/FSI < 12.000$	PB	0	-	$0.0417FSI$	kHz
Stopband	$0.1667 \leq FSO/FSI < 12.000$	SB	$0.4167FSI$	-		kHz
Passband Ripple		PR	-	-	$\pm 0.01$	dB
Stopband Attenuation		SA	-	108.1	-	dB
Group Delay	(Note 9)	GD	-	64	-	1/fs

Note 9. This is the time from a rising edge of ILRCK after L and R channels data is input to a rising edge of OLRCK before the L and R channels data is output, when there is no phase difference between input and output data.

### ■ Short Delay Sharp Roll-Off Filter Characteristics

(Ta=-40~ +105°C; DVDD=3.0~3.6V or DVDD=DV18=1.7V~1.9V, DVSS=0V)

Parameter	Symbol	Min.	Typ.	Max.	Unit	
<b>Digital Filter</b>						
Passband -0.01dB	$0.985 \leq \text{FSO/FSI} \leq 12.000$	PB	0	-	0.4583FSI	kHz
	$0.905 \leq \text{FSO/FSI} < 0.985$	PB	0	-	0.4167FSI	kHz
	$0.714 \leq \text{FSO/FSI} < 0.905$	PB	0	-	0.3195FSI	kHz
	$0.656 \leq \text{FSO/FSI} < 0.714$	PB	0	-	0.2852FSI	kHz
	$0.536 \leq \text{FSO/FSI} < 0.656$	PB	0	-	0.2182FSI	kHz
	$0.492 \leq \text{FSO/FSI} < 0.536$	PB	0	-	0.2177FSI	kHz
	$0.452 \leq \text{FSO/FSI} < 0.492$	PB	0	-	0.1948FSI	kHz
	$0.357 \leq \text{FSO/FSI} < 0.452$	PB	0	-	0.1458FSI	kHz
	$0.324 \leq \text{FSO/FSI} < 0.357$	PB	0	-	0.1302FSI	kHz
	$0.246 \leq \text{FSO/FSI} < 0.324$	PB	0	-	0.0917FSI	kHz
	$0.226 \leq \text{FSO/FSI} < 0.246$	PB	0	-	0.0826FSI	kHz
$0.1667 \leq \text{FSO/FSI} < 0.226$	PB	0	-	0.0583FSI	kHz	
Stopband	$0.985 \leq \text{FSO/FSI} \leq 12.000$	SB	0.5417FSI	-	-	kHz
	$0.905 \leq \text{FSO/FSI} < 0.985$	SB	0.5021FSI	-	-	kHz
	$0.714 \leq \text{FSO/FSI} < 0.905$	SB	0.3965FSI	-	-	kHz
	$0.656 \leq \text{FSO/FSI} < 0.714$	SB	0.3643FSI	-	-	kHz
	$0.536 \leq \text{FSO/FSI} < 0.656$	SB	0.2974FSI	-	-	kHz
	$0.492 \leq \text{FSO/FSI} < 0.536$	SB	0.2813FSI	-	-	kHz
	$0.452 \leq \text{FSO/FSI} < 0.492$	SB	0.2604FSI	-	-	kHz
	$0.357 \leq \text{FSO/FSI} < 0.452$	SB	0.2116FSI	-	-	kHz
	$0.324 \leq \text{FSO/FSI} < 0.357$	SB	0.1969FSI	-	-	kHz
	$0.246 \leq \text{FSO/FSI} < 0.324$	SB	0.1573FSI	-	-	kHz
	$0.226 \leq \text{FSO/FSI} < 0.246$	SB	0.1471FSI	-	-	kHz
$0.1667 \leq \text{FSO/FSI} < 0.226$	SB	0.1020FSI	-	-	kHz	
Passband Ripple	$0.226 \leq \text{FSO/FSI} \leq 12.000$	PR	-	-	±0.01	dB
	$0.1667 \leq \text{FSO/FSI} < 0.226$	PR	-	-	±0.03	dB
Stopband Attenuation	$0.985 \leq \text{FSO/FSI} \leq 24.000$	SA	140.2	-	-	dB
	$0.905 \leq \text{FSO/FSI} < 0.985$	SA	140.9	-	-	dB
	$0.714 \leq \text{FSO/FSI} < 0.905$	SA	135.2	-	-	dB
	$0.656 \leq \text{FSO/FSI} < 0.714$	SA	135.1	-	-	dB
	$0.536 \leq \text{FSO/FSI} < 0.656$	SA	133.5	-	-	dB
	$0.492 \leq \text{FSO/FSI} < 0.536$	SA	115.3	-	-	dB
	$0.452 \leq \text{FSO/FSI} < 0.492$	SA	118.2	-	-	dB
	$0.357 \leq \text{FSO/FSI} < 0.452$	SA	123.3	-	-	dB
	$0.324 \leq \text{FSO/FSI} < 0.357$	SA	122.9	-	-	dB
	$0.246 \leq \text{FSO/FSI} < 0.324$	SA	117.9	-	-	dB
	$0.226 \leq \text{FSO/FSI} < 0.246$	SA	119.7	-	-	dB
$0.1667 \leq \text{FSO/FSI} < 0.226$	SA	90.3	-	-	dB	
Group Delay (Note 9)	$0.905 \leq \text{FSO/FSI} \leq 12.000$	GD	-	20	-	1/fs
	$0.656 \leq \text{FSO/FSI} < 0.905$	GD	-	22	-	1/fs
	$0.536 \leq \text{FSO/FSI} < 0.656$	GD	-	26	-	1/fs
	$0.492 \leq \text{FSO/FSI} < 0.536$	GD	-	23	-	1/fs
	$0.452 \leq \text{FSO/FSI} < 0.492$	GD	-	24	-	1/fs
	$0.324 \leq \text{FSO/FSI} < 0.452$	GD	-	26	-	1/fs
	$0.246 \leq \text{FSO/FSI} < 0.324$	GD	-	29	-	1/fs
	$0.226 \leq \text{FSO/FSI} < 0.246$	GD	-	30	-	1/fs
$0.1667 \leq \text{FSO/FSI} < 0.226$	GD	-	32	-	1/fs	

Note 9. This is the time from a rising edge of ILRCK after L and R channels data is input to a rising edge of OLRCK before the L and R channels data is output, when there is no phase difference between input and output data.

### ■ Short Delay Slow Roll-Off Filter Characteristics

(Ta=-40~ +105°C; DVDD=3.0~3.6V or DVDD=DV18=1.7V~1.9V, DVSS=0V)

Parameter		Symbol	Min.	Typ.	Max.	Unit
<b>Digital Filter</b>						
Passband -0.01dB	0.1667≤FSO/FSI < 12.000	PB	0	-	0.0417FSI	kHz
Stopband	0.1667≤FSO/FSI < 12.000	SB	0.4167FSI	-		kHz
Passband Ripple		PR	-	-	±0.01	dB
Stopband Attenuation		SA	-	108.1	-	dB
Group Delay (Note 9)		GD	-	21	-	1/fs

Note 9. This is the time from a rising edge of ILRCK after L and R channels data is input to a rising edge of OLRCK before the L and R channels data is output, when there is no phase difference between input and output data.

## 11. Input and Output Examples

Possible Input and Output data combinations are shown below.

Fsi is the sampling rate of input data, and Fso is the sampling rate of output data.

Fsi[kHz]	Fso[kHz]	
PCM	PCM	
	min	max
8	8	96
11.025	8	132.3
16	8	192
32	8	384
44.1	8	384
48	8	384
88.2	14.7	384
96	16	384
176.4	29.6	384
192	32	384

When the input data is 384 kHz and down converted, THD+N may degrade to 80dB.

### 12. DC Characteristics

(Ta=-40~ +105°C; DVDD=3.0~3.6V; VSEL pin = "L" or DVDD=DV18=1.7V~1.9V: VSEL pin = "H")

Parameter	Symbol	Min.	Typ.	Max.	Unit
High-Level Input Voltage	V <sub>IH</sub>	70%DVDD	-	-	V
Low-Level Input Voltage	V <sub>IL</sub>	-	-	30%DVDD	V
High-Level Output Voltage Except SDA pin (I <sub>out</sub> =-400μA)	V <sub>OH</sub>	DVDD-0.4	-	-	V
Low-Level Output Voltage Except SDA pin (I <sub>out</sub> =400μA)	V <sub>OL</sub>	-	-	0.4	V
SDA pin (I <sub>out</sub> =3mA)	V <sub>OL</sub>	-	-	0.4	V
Input Leakage Current	I <sub>in</sub>	-	-	±10	μA

### 13. Switching Characteristics

(Ta=-40~ +105°C; DVDD=3.0~3.6V; VSEL pin = "L" or DVDD=DV18=1.7V~1.9V: VSEL pin = "H"; C<sub>L</sub>=20pF)

Parameter	Symbol	Min.	Typ.	Max.	Unit
<b>Master Clock Timing</b>					
Crystal Oscillator Frequency (256 times of 44.1, 48, 88.2 or 96kHz)	f <sub>X<sub>TAL</sub></sub>	11.2896	-	24.576	MHz
OMCLK Input					
128 FSO:	f <sub>CLK</sub>	1.024		49.152	MHz
Pulse Width Low	t <sub>CLKL</sub>	7			ns
Pulse Width High	t <sub>CLKH</sub>	7			ns
256 FSO:	f <sub>CLK</sub>	2.048		49.152	MHz
Pulse Width Low	t <sub>CLKL</sub>	7			ns
Pulse Width High	t <sub>CLKH</sub>	7			ns
384 FSO:	f <sub>CLK</sub>	3.072		36.864	MHz
Pulse Width Low	t <sub>CLKL</sub>	10			ns
Pulse Width High	t <sub>CLKH</sub>	10			ns
512 FSO:	f <sub>CLK</sub>	4.096		49.152	MHz
Pulse Width Low	t <sub>CLKL</sub>	7			ns
Pulse Width High	t <sub>CLKH</sub>	7			ns
768 FSO:	f <sub>CLK</sub>	6.144		36.864	MHz
Pulse Width Low	t <sub>CLKL</sub>	10			ns
Pulse Width High	t <sub>CLKH</sub>	10			ns



Parameter	Symbol	Min.	Typ.	Max.	Unit
<b>Input PORT ILRCK</b>					
Frequency					kHz
Normal speed mode	FSIN	8		54	kHz
Double speed mode	FSID	54		108	kHz
Quad speed mode	FSIQ	108		216	kHz
Oct speed mode	FSIO		384		kHz
Duty Cycle Slave Mode	Duty	48	50	52	%
<b>Output PORT OLRCK</b>					
Frequency					
Slave mode					
Normal speed mode	FSON	8		54	kHz
Double speed mode	FSOD	54		108	kHz
Quad speed mode	FSOQ	108		216	kHz
Oct speed mode	FSOO		384		kHz
Master mode					
OMCLK Input, 128FSO mode	FSO	8		384	kHz
OMCLK Input, 256FSO mode	FSO	8		192	kHz
OMCLK Input, 384FSO mode	FSO	8		96	kHz
OMCLK Input, 512FSO mode	FSO	8		96	kHz
OMCLK Input, 768FSO mode	FSO	8		48	kHz
Duty Cycle					
Slave Mode	Duty	48	50	52	%
Master Mode	Duty		50		%
<b>Input PORT ILRCK for TDM256 Mode</b>					
Frequency	FSI	8		96	kHz
"H" time (slave mode)	tLRH	1/256FSI			ns
"L" time (slave mode)	tLRL	1/256FSI			ns
<b>Input PORT ILRCK for TDM512 Mode</b>					
Frequency	FSI	8		48	kHz
"H" time (slave mode)	tLRH	1/512FSI			ns
"L" time (slave mode)	tLRL	1/512FSI			ns
<b>Output PORT OLRCK for TDM256 Mode</b>					
Frequency	FSO	8		96	kHz
"H" time (slave mode)	tLRH	1/256 FSO			ns
"L" time (slave mode)	tLRL	1/256 FSO			ns
<b>Output PORT OLRCK for TDM512 Mode</b>					
Frequency	FSO	8		48	kHz
"H" time (slave mode)	tLRH	1/512 FSO			ns
"L" time (slave mode)	tLRL	1/512 FSO			ns

Parameter	Symbol	Min.	Typ.	Max.	Unit
<b>Audio Interface Timing</b>					
<b>Input PORT (Slave mode)</b>					
IBICK Period					
Normal speed mode	tBCK	1/256 FSIN			ns
Double speed mode	tBCK	1/128 FSID			ns
Quad speed mode	tBCK	1/64 FSIQ			ns
Oct speed mode	tBCK	1/64 FSIO			ns
IBICK Pulse Width Low	tBCKL	16			ns
IBICK Pulse Width High	tBCKH	16			ns
ILRCK Edge to IBICK "↑" (Note 10)	tLRB	10			ns
IBICK "↑" to ILRCK Edge (Note 10)	tBLR	10			ns
SDTI Hold Time from IBICK "↑"	tSDH	10			ns
SDTI Setup Time to IBICK "↑"	tSDS	6			ns
<b>Input PORT (TDM256 slave mode)</b>					
IBICK Period	tBCK	40			ns
IBICK Pulse Width Low	tBCKL	16			ns
IBICK Pulse Width High	tBCKH	16			ns
ILRCK Edge to IBICK "↑" (Note 10)	tLRB	10			ns
IBICK "↑" to ILRCK Edge (Note 10)	tBLR	10			ns
SDTI Hold Time from IBICK "↑"	tSDH	10			ns
SDTI Setup Time to IBICK "↑"	tSDS	6			ns
<b>Input PORT (TDM512 slave mode)</b>					
IBICK Period	tBCK	40			ns
IBICK Pulse Width Low	tBCKL	16			ns
IBICK Pulse Width High	tBCKH	16			ns
ILRCK Edge to IBICK "↑" (Note 10)	tLRB	10			ns
IBICK "↑" to ILRCK Edge (Note 10)	tBLR	10			ns
SDTI Hold Time from IBICK "↑"	tSDH	10			ns
SDTI Setup Time to IBICK "↑"	tSDS	6			ns

Note 10. IBICK rising edge must not occur at the same time as ILRCK edge.

Note 11. Maximum frequency of IBICK and OBICK is 24.576MHz.

Parameter	Symbol	Min.	Typ.	Max.	Unit
<b>Audio Interface Timing</b>					
<b>Output PORT (Slave mode)</b>					
OBICK Period					
Normal speed mode	tBCK	1/256 FSON			
Double speed mode	tBCK	1/128 FSOD			
Quad speed mode	tBCK	1/64 FSOQ			
Oct speed mode	tBCK	1/64 FSOO			
OBICK Pulse Width Low	tBCKL	16			ns
OBICK Pulse Width High	tBCKH	16			ns
OLRCK Edge to OBICK "↑" (Note 10)	tLRB	10			ns
OBICK "↑" to OLRCK Edge (Note 10)	tBLR	10			ns
DVDD=3.0V~3.6V (VSEL pin= "L")					
OLRCK to SDTO(MSB) (Except I <sup>2</sup> S mode)	tLRS			10	ns
OBICK "↓" to SDTO	tBSD			10	ns
DVDD=1.7V~1.9V (VSEL pin= "H")					
(Except fso=384kHz)					
OLRCK to SDTO(MSB) (Except I <sup>2</sup> S mode)	tLRS			20	ns
OBICK "↓" to SDTO	tBSD			20	ns

Note 10. IBICK rising edge must not occur at the same time as ILRCK edge.

Parameter	Symbol	Min.	Typ.	Max.	Unit
<b>Audio Interface Timing</b>					
<b>Output PORT (TDM256 slave mode)</b>					
DVDD=3.0V~3.6V (VSEL pin= "L")					
OBICK Period	tBCK	40			ns
OBICK Pulse Width Low	tBCKL	16			ns
OBICK Pulse Width High	tBCKH	16			ns
OLRCK Edge to OBICK "↑" (Note 10)	tLRB	10			ns
OBICK "↑" to OLRCK Edge (Note 10)	tBLR	10			ns
OBICK "↓" to SDTO	tBSD			10	ns
DVDD=1.7V~1.9V (VSEL pin= "H")					
OBICK Period	tBCK	80			ns
OBICK Pulse Width Low	tBCKL	32			ns
OBICK Pulse Width High	tBCKH	32			ns
OLRCK Edge to OBICK "↑" (Note 10)	tLRB	20			ns
OBICK "↑" to OLRCK Edge (Note 10)	tBLR	20			ns
OBICK "↓" to SDTO	tBSD			20	sn
<b>Output PORT (TDM512 slave mode)</b>					
DVDD=3.0V~3.6V(VSEL pin= "L")					
OBICK Period	tBCK	40			ns
OBICK Pulse Width Low	tBCKL	16			ns
OBICK Pulse Width High	tBCKH	16			ns
OLRCK Edge to OBICK "↑" (Note 10)	tLRB	10			ns
OBICK "↑" to OLRCK Edge (Note 10)	tBLR	10			ns
OBICK "↓" to SDTO	tBSD			10	ns
<b>Output PORT (Master mode)</b>					
OBICK Frequency	fBCK		64 FSO		Hz
OBICK Duty	dBCK		50		%
OBICK "↓" to OLRCK Edge	tMBLR	-5		5	ns
OBICK "↓" to SDTO	tBSD	-5		5	ns
<b>Reset Timing</b>					
PDN "L" Width after DVDD is on. (Note 13)	tAPD1	150			ns
PDN Accept Pulse Width (Note 13)	tAPD2	700			ms
PDN pin Pulse Width of Spike Noise Suppressed by Input Filter (Note 14)	tPDS	0		50	ns

Note 10. IBICK rising edge must not occur at the same time as ILRCK edge.

Note 12. TDM modes are only supported in slave mode.

Note 13. The AK4136 can be reset by bringing the PDN pin = "L".

Note 14. "L" pulse width of spike noise suppressed by input filter of the PDN pin.

Parameter	Symbol	Min.	Typ.	Max.	Unit
<b>Control Interface Timing</b>					
CCLK Period	tCCK	200		-	ns
CCLK Pulse Width High	tCCKH	80		-	ns
CCLK Pulse Width Low	tCCKL	80		-	ns
CDTI Setup Time	tCDS	50		-	ns
CDTI Hold Time	tCDH	50		-	ns
CSN High Time	tCSW	150		-	ns
CSN "↓" to CCLK "↑"	tCSS	50		-	ns
CCLK "↑" to CSN "↑"	tCSH	50		-	ns
CCLK "↓" to CDTO	tDCD			45	ns
CSN "↑" to CDTO "Hi-Z"	tCCZ			70	ns
<b>Control Interface Timing (I<sup>2</sup>C Bus):</b>					
SCL Clock Frequency	fSCL	-		400	kHz
Bus Free Time Between Transmissions	tBUF	1.3		-	μs
Start Condition Hold Time (prior to first clock pulse)	tHD:STA	0.6		-	μs
Clock Low Time	tLOW	1.3		-	μs
Clock High Time	tHIGH	0.6		-	μs
Setup Time for Repeated Start Condition	tSU:STA	0.6		-	μs
SDA Hold Time from SCL Falling (Note 15)	tHD:DAT	0		-	μs
SDA Setup Time from SCL Rising	tSU:DAT	0.1		-	μs
Rise Time of Both SDA and SCL Lines	tR	-		0.3	μs
Fall Time of Both SDA and SCL Lines	tF	-		0.3	μs
Setup Time for Stop Condition	tSU:STO	0.6		-	μs
Pulse Width of Spike Noise Suppressed by Input Filter	tSP	0		50	ns
Capacitive load on bus	Cb	-		400	pF

Note 15. Data must be held for sufficient time to bridge the 300 ns transition time of SCL.

■ Timing Diagrams

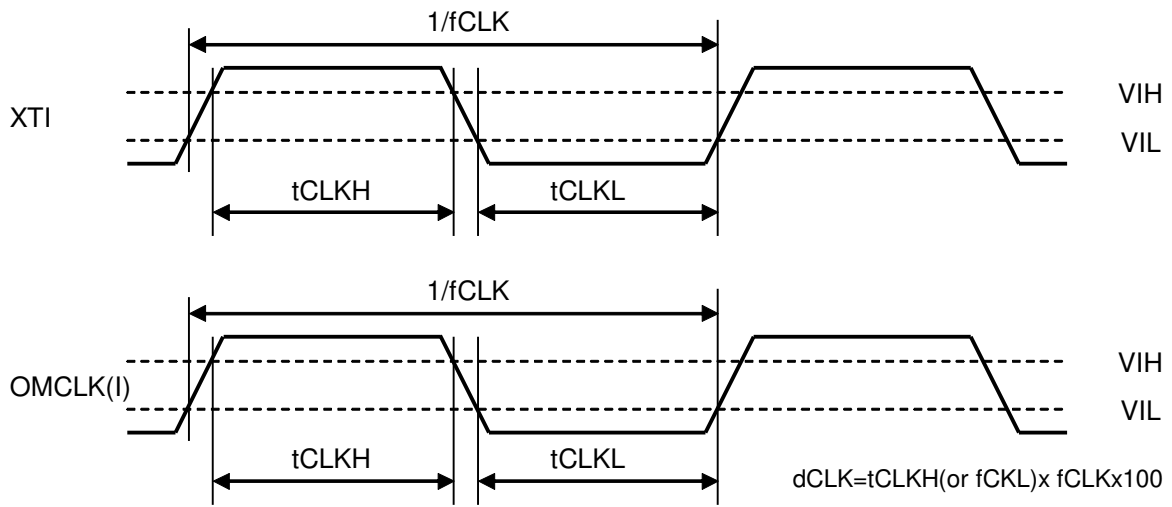
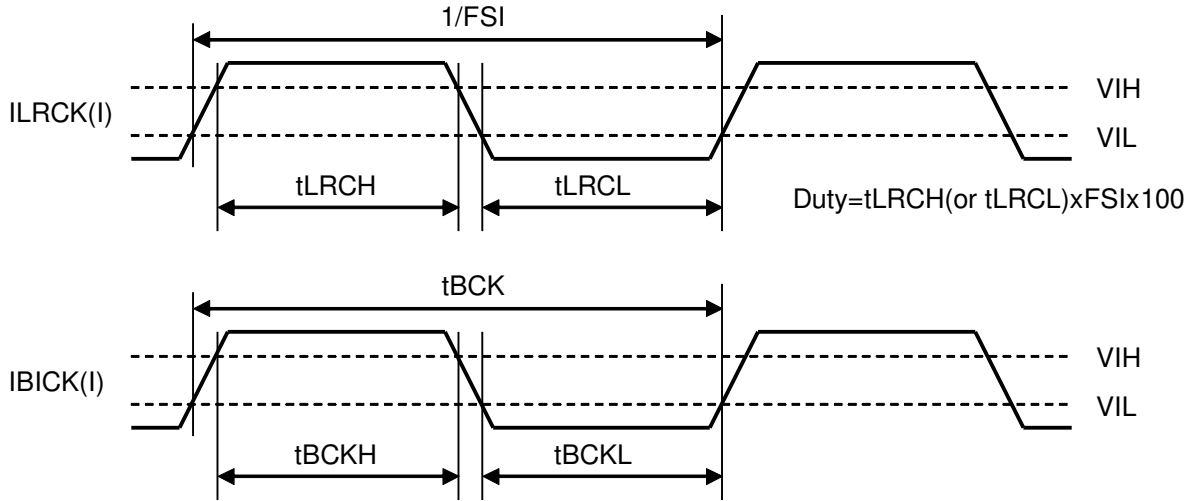

Figure 3. OMCLK, Clock Timing

**Slave Mode**



**TDM256 or TDM512 Mode and Slave Mode**

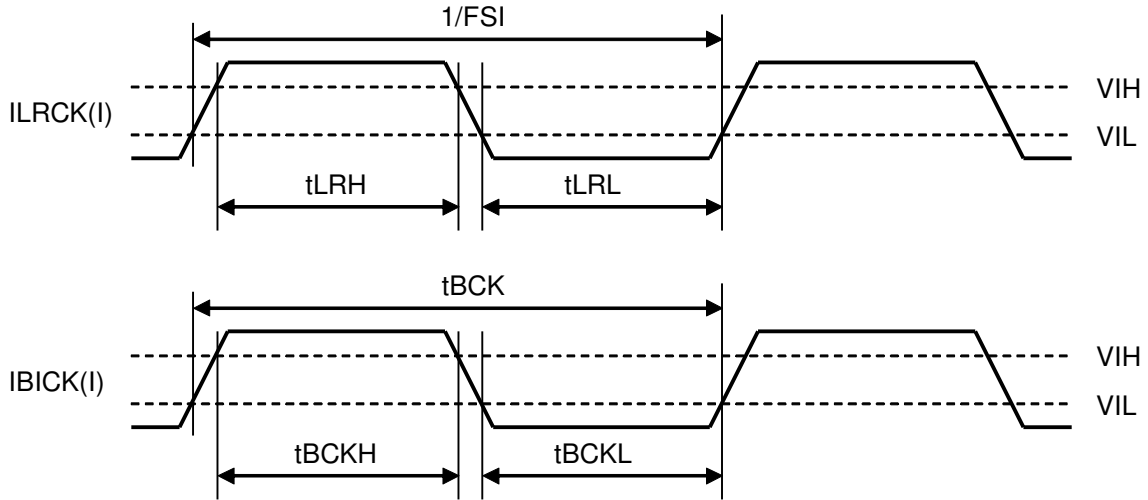
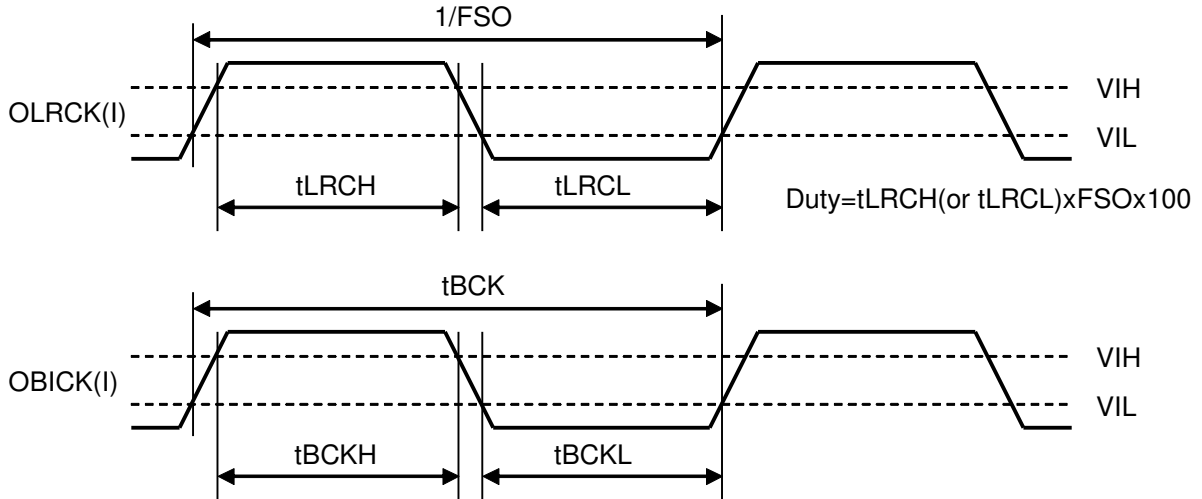

Figure 4. ILRCK, IBICK Clock Timing

**Slave Mode**



**TDM256 or TDM512 Mode and Slave Mode**

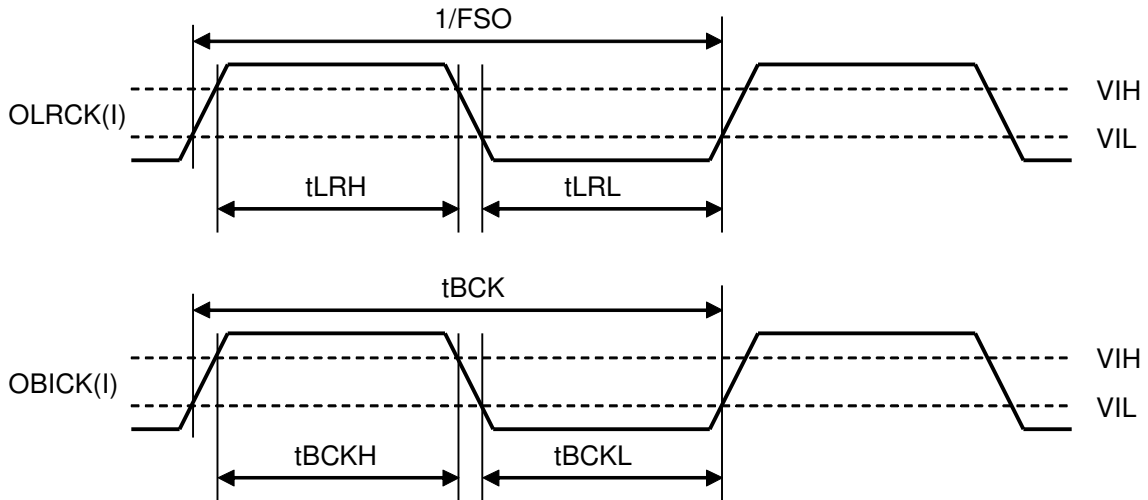

Figure 5. OLRCK, OBICK Clock Timing (Slave Mode)

**Master Mode**

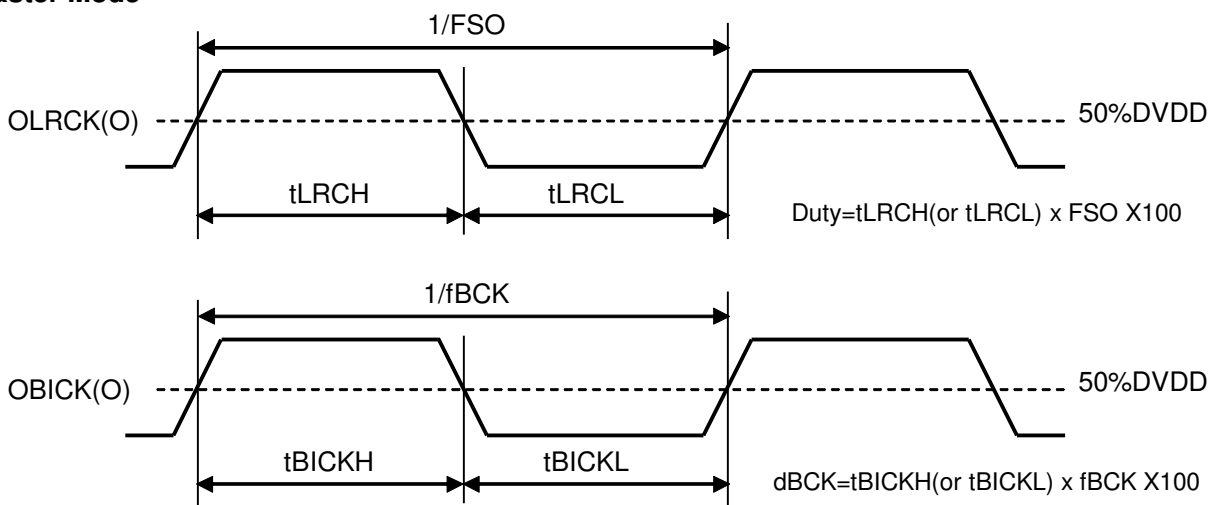

Figure 6. OLRCK, OBICK Clock Timing (Master Mode)



**Slave mode and TDM256 or TDM512 Slave Mode**

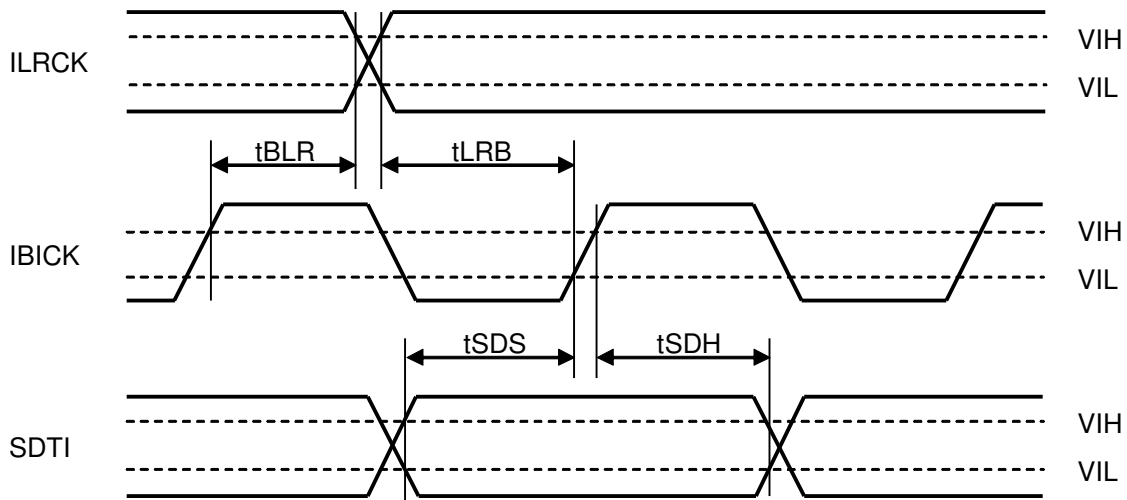

Figure 7. Input PORT Audio Interface Timing

**Slave mode and TDM256 or TDM512 Slave Mode**

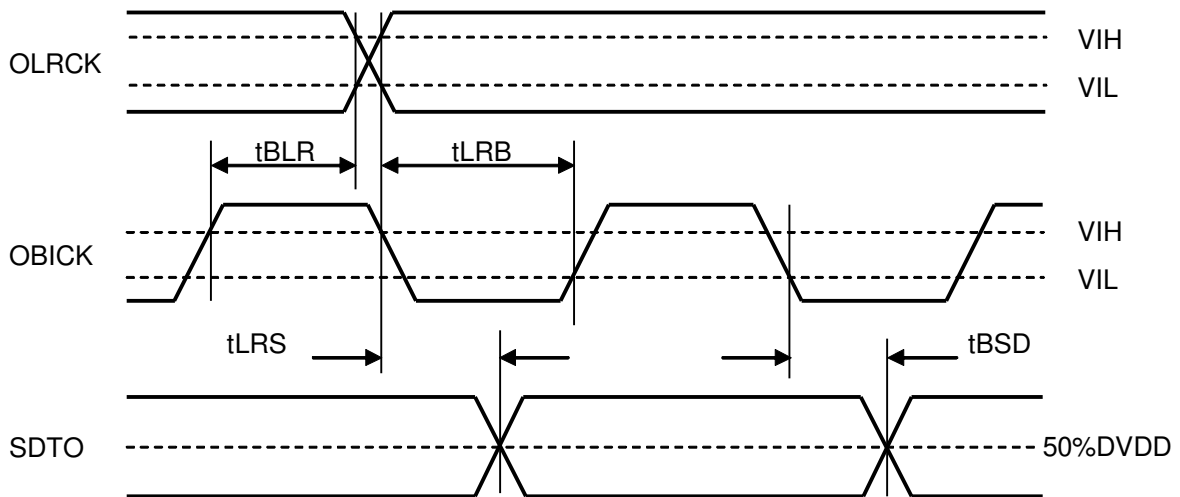

Figure 8. Output PORT Audio Interface Timing

**Master mode and TDM256 or TDM512 Master mode**

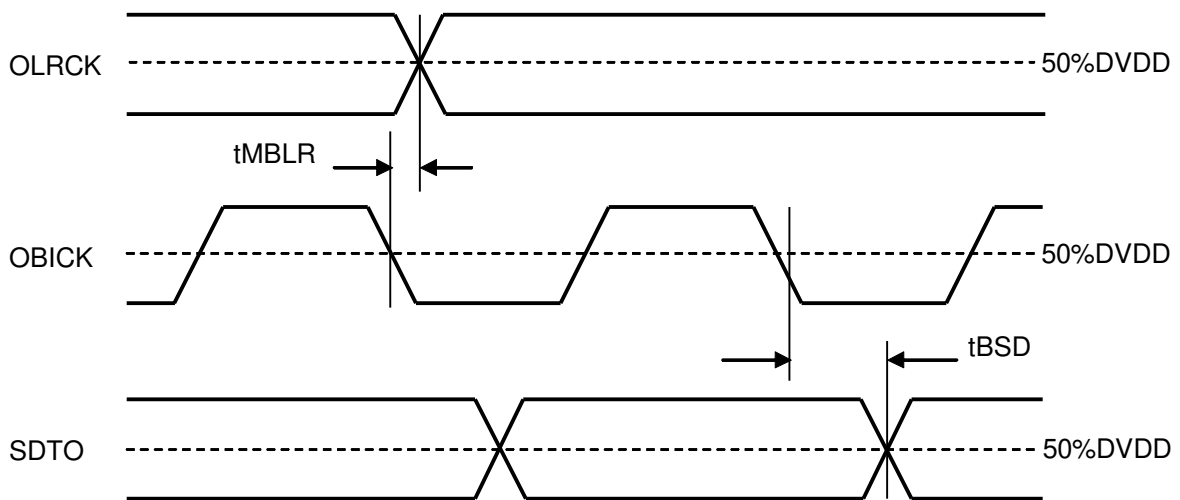

Figure 9. Output PORT Audio Interface Timing

4-Wire Read

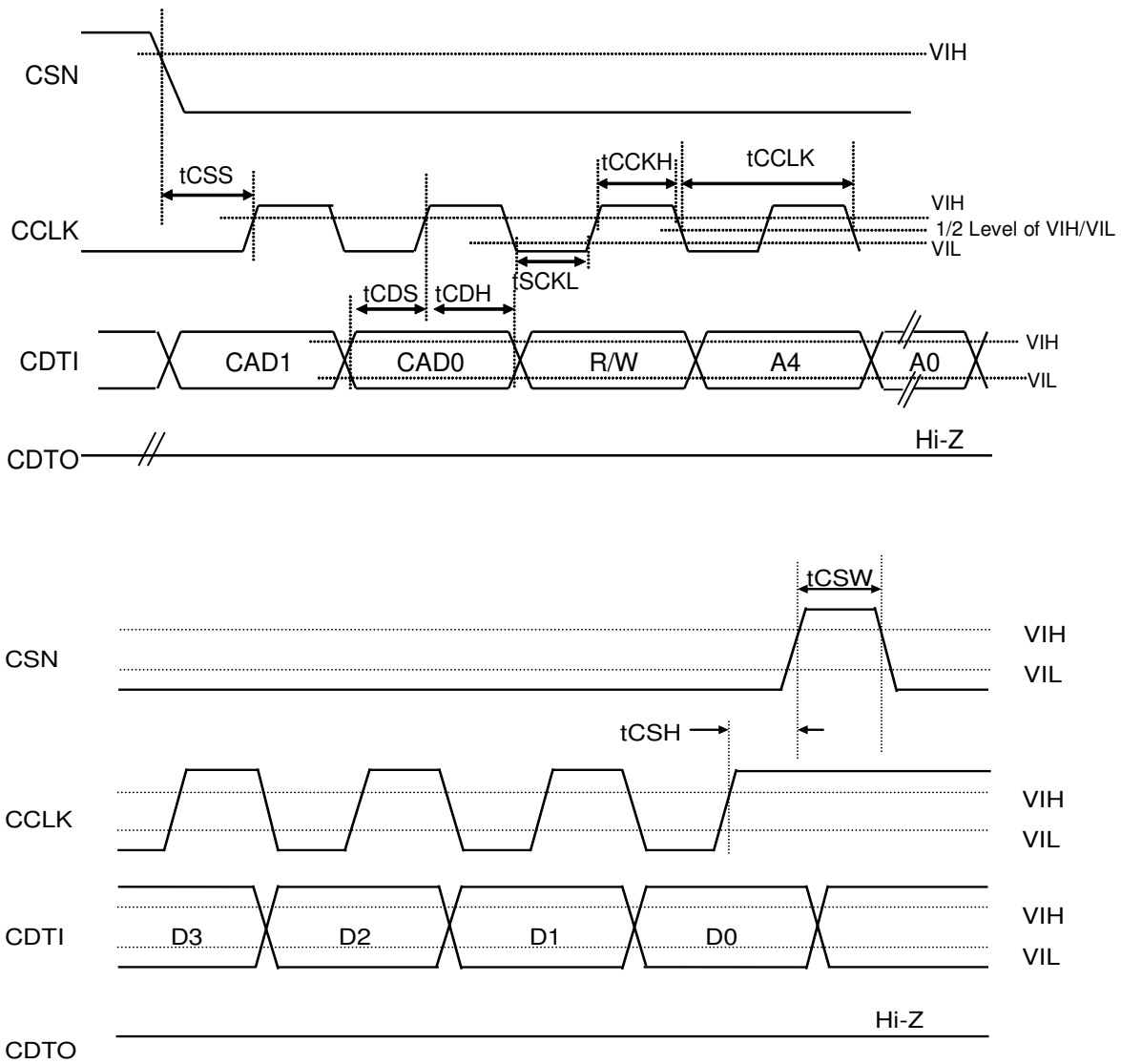

Figure 10. 4-wire Serial Control Mode

4Wire Write

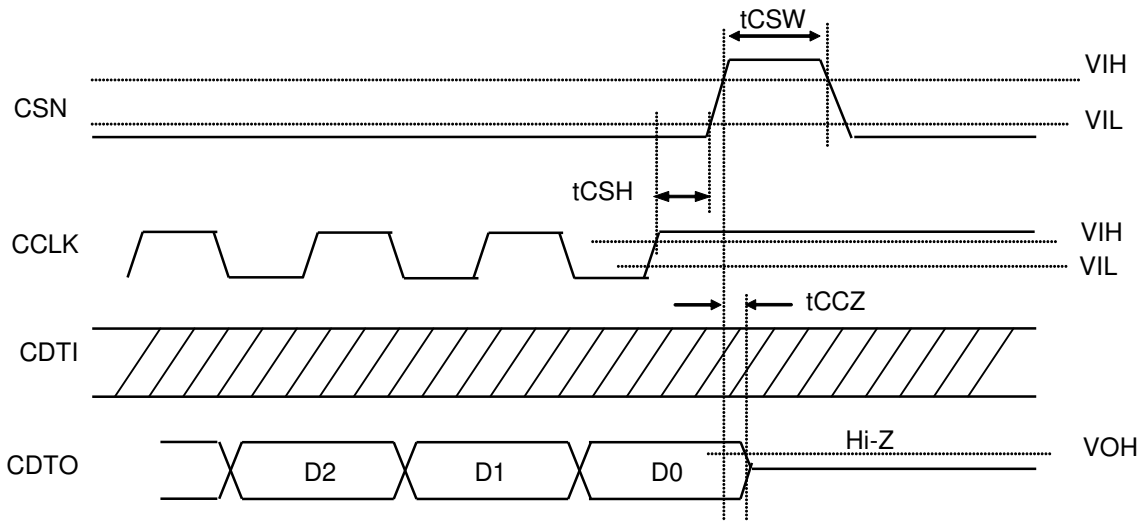
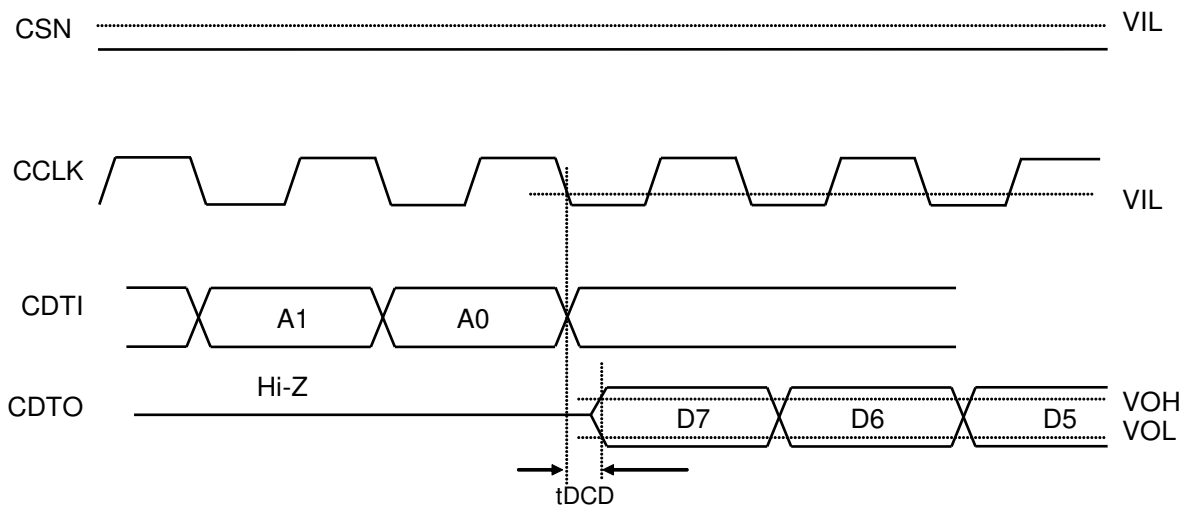

Figure 11. 4-wire Serial Control Mode

I2C Bus Control Mode

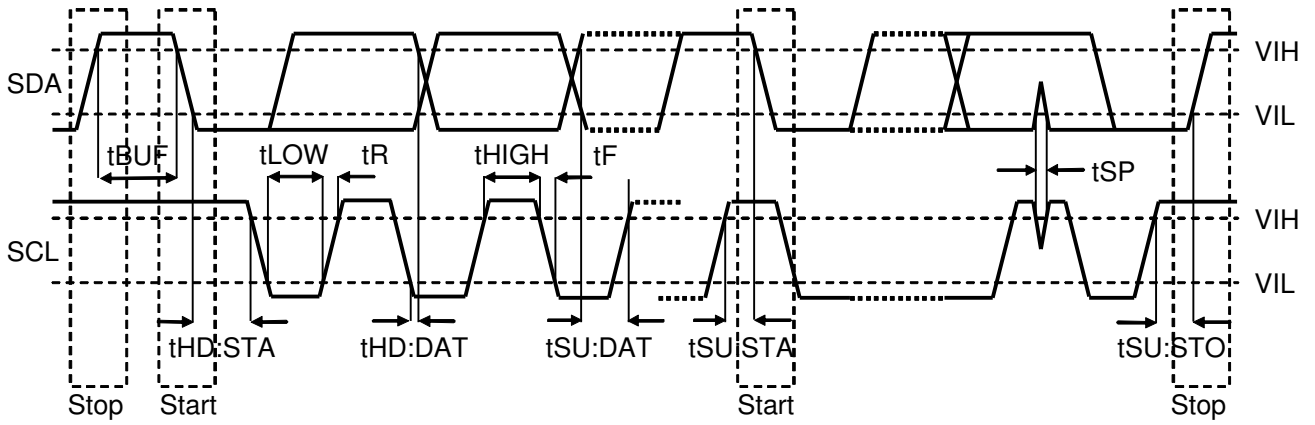

Figure 12. I2C Bus Control Mode

PDN

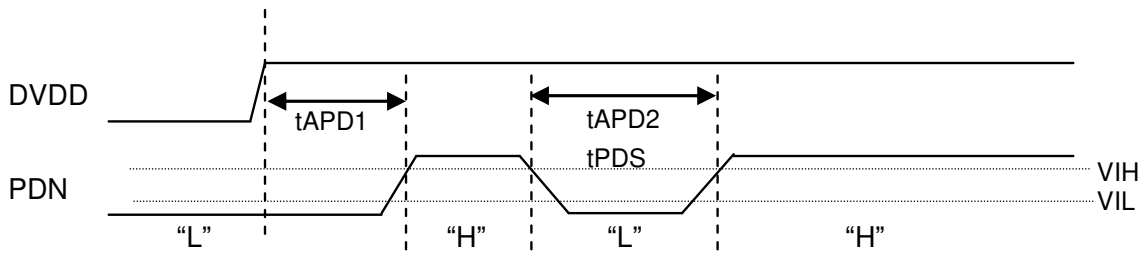

Figure 13. Power Down & Reset Timing

**14.Functional Descriptions**

**■ Power-up Sequence**

VSEL pin= "L" (regulator mode)

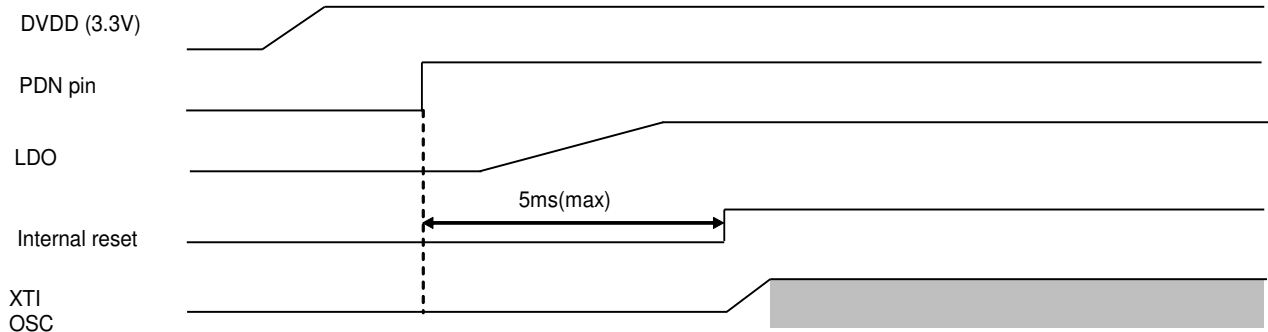

Figure 14. Power-up Sequence (Regulator Mode)

VSEL pin= "H" (regulator off mode)

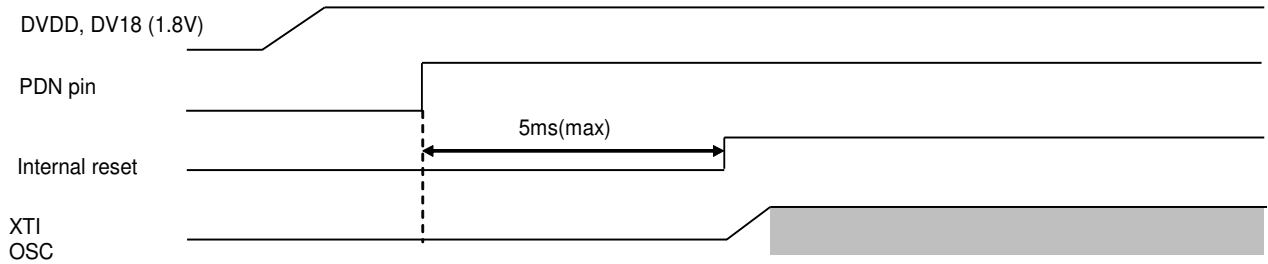

Figure 15. Power-up Sequence (Regulator Off Mode)

■ SRC Bypass Mode

1. SRC Mode Setting

In parallel control mode (PSN pin = "H"), the CM2-0 pins selects SRC bypass mode or SRC mode. The CM2-0 pins select the master/slave mode and system clock simultaneously. (Table 6)

Table 1. SRC/SRC Bypass Mode Setting (@Parallel Control Mode)

Mode	CM2 pin	CM1 pin	CM0 pin	SRC Mode / SRC Bypass Mode
0	L	L	L	SRC Mode
1	L	L	H	
2	L	H	L	
3	L	H	H	
4	H	L	L	
5	H	L	H	SRC Bypass Mode
6	H	H	L	
7	H	H	H	

In serial control mode (PSN pin = "L"), BYPS bit selects SRC bypass mode or SRC mode. The default value of the BYPS bit is "0" (SRC mode).

Table 2. SRC/SRC Bypass Mode Setting (@Serial Control Mode)

BYPS bit	SRC mode
0	SRC (Default)
1	Bypass

2. SRC Bypass Mode

- PCMIN → PCMOUT Mode (Slave Mode)

SDTI input data is clocked in by ILRCK and IBICK according to the audio interface format shown in Table 3. SDTO output data is clocked out by OLRCK and OBICK according to the audio interface format shown in Table 8 and Table 9. OBICK must be synchronized with IBICK but the phase is not critical. OLRCK must be synchronized with ILRCK but the phase is not critical.

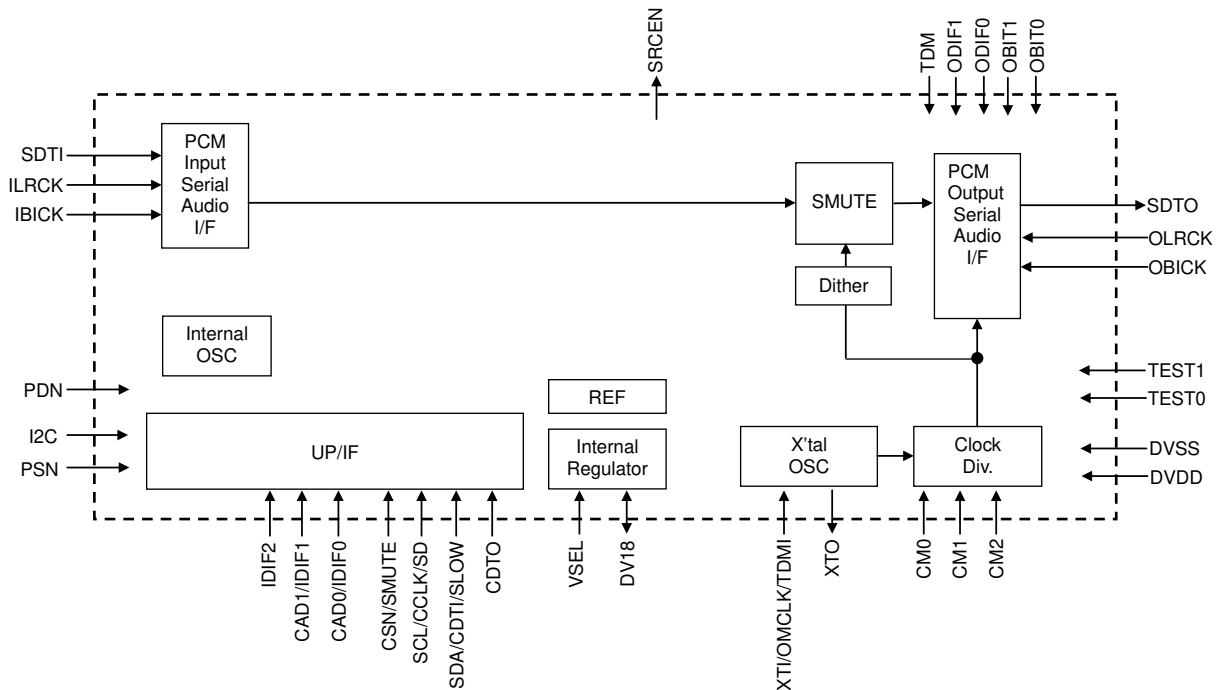

Figure 16. BYPASS Mode Slave (PCMIN→PCMOUT)

• PCMIN → PCMOUT Mode (Master Mode)

SDTI input data is clocked in by ILRCK and IBICK according to the audio interface format shown in Table 3. SDTO output data is clocked out by ILRCK and IBICK according to the audio interface format shown in Table 8 and Table 9. In this case, ILRCK is directly output from the OLRCK pin, and IBICK is directly output from the OBICK pin.

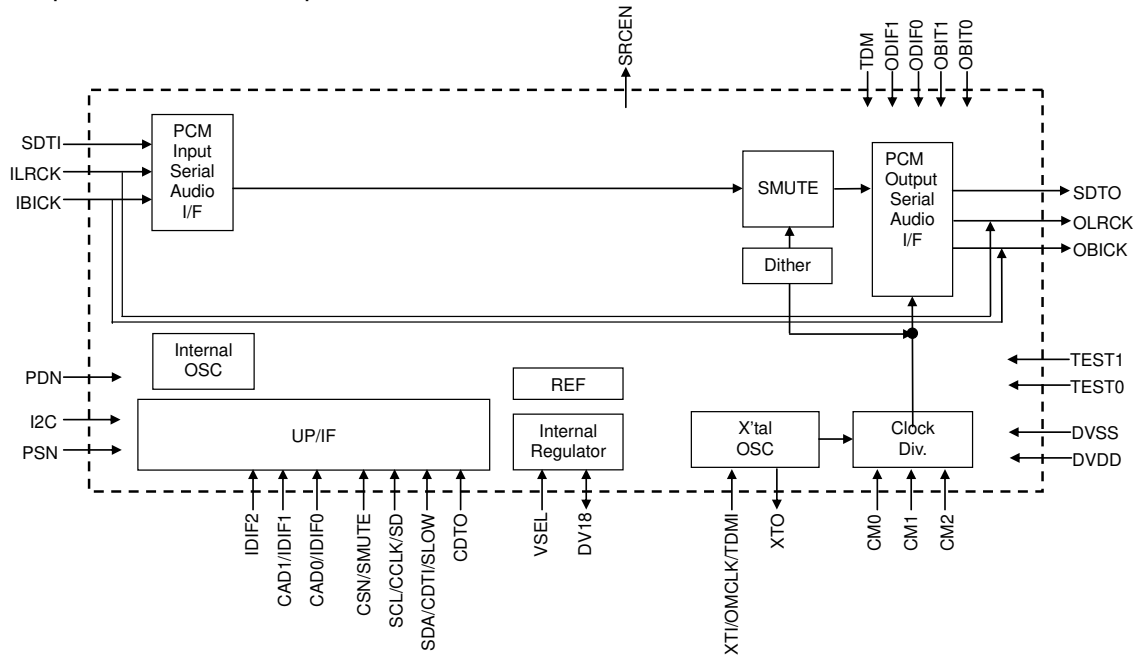

Figure 17. BYPASS Mode Master (PCMIN→PCMOUT)

## ■ System Clock and Audio Interface Format for Input PORT

The input port of the AK4136 only supports slave mode. Both ILRCK and IBICK pins are inputs and master clock supplies are not necessary. The audio data format of input port is MSB first, 2's complement format. The SDTI is latched on the rising edge of IBICK.

In parallel control mode (PSN pin= "H"), IDIF2-0 pins control all audio interface formats of the input port. IDIF2-0 pins must be set during the PDN pin= "L".

In serial control mode (PSN pin = "L"), the setting of IDIF2-0 pins is ignored and IDIF2-0 bits setting is reflected. IDIF2-0 bits should be changed after all SDTO output codes become zero during soft mute by SMUTE bit = "1" or the SMUTE pin = "H".

Table 3. Input PORT Audio Interface Format

Mode	IDIF2 Pin/Bit (Note 17)	IDIF1 Pin/Bit (Note 17)	IDIF0 Pin/Bit (Note 17)	SDTI Format	ILRCK	IBICK	IBICK Freq
0	L	L	L	32bit, LSB justified	Input	Input	256FSI ≥ ≥64FSI
1	L	L	H	24bit, LSB justified			256FSI ≥ ≥ 48FSI
2	L	H	L	32bit, MSB justified			256FSI ≥ ≥ 64FSI
3	L	H	H	32 or 16 bit, I <sup>2</sup> S Compatible			256FSI ≥ ≥ 64FSI
				16 bit, I <sup>2</sup> S Compatible			32FSI
4	H	L	L	TDM 32bit, MSB justified			256FSI
5	H	L	H	TDM 32bit, I <sup>2</sup> S Compatible			
6	H	H	L	TDM 32bit, MSB justified			
7	H	H	H	TDM 32bit, I <sup>2</sup> S Compatible	512FSI		

Note 16. When IBICK = 32FSI, the AK4136 only supports 16-bit I<sup>2</sup>S Compatible format.

Note 17. In serial control mode (PSN pin = "L"), the setting of IDIF2-0 bit is valid. In parallel control mode (PSN pin = "H"), the setting of IDIF2-0 pin is valid.

Note 18. In case parallel control mode, L1 and R1 are selected data channels in TDM input mode. In case serial control mode, the data channels are selected by TDMICH2-0 bits setting in TDM input mode.

Mode 4 and 5 (TDM256), R1 is available in below frequency range.

ILRCK: 8kHz to 18kHz, 21.8295kHz to 36kHz, 43.4385kHz to 71.5kHz, 86.436kHz to 96kHz

Mode 6 and 7 (TDM512), R1 is available in below frequency range.

ILRCK: 8kHz to 9kHz

Mode 6 and 7 (TDM512), in case TDMICH2-0bit = "001" (just Parallel Control mode), R2 is available in below frequency range.

ILRCK: 8kHz to 18kHz, 21.8295kHz to 36kHz, 43.4385kHz to 48kHz

Regarding L1, R1 and R2, please refer [Figure 22](#), [Figure 23](#), [Figure 24](#) and [Figure 25](#).



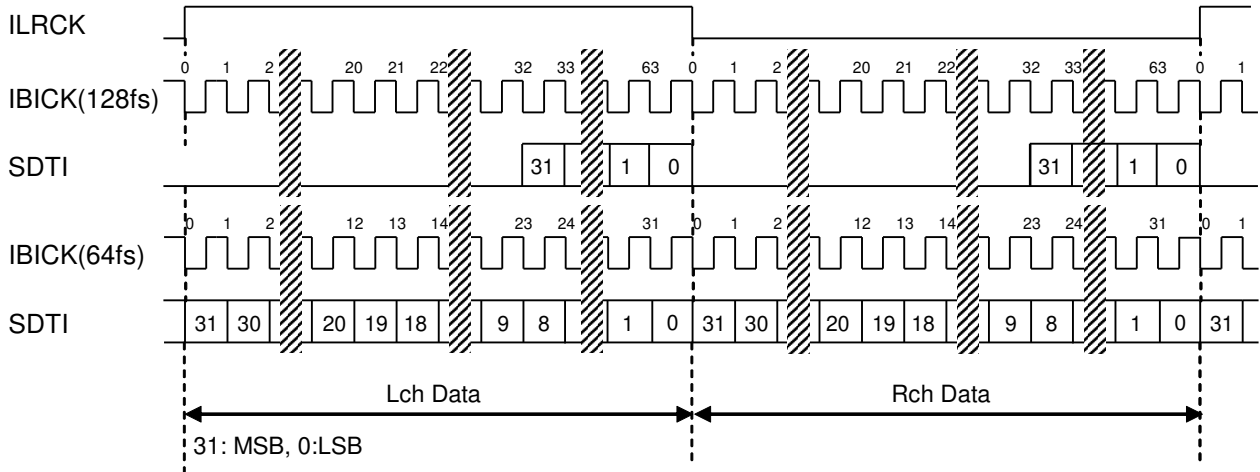

Figure 18. Mode0 Timing (32-bit LSB)

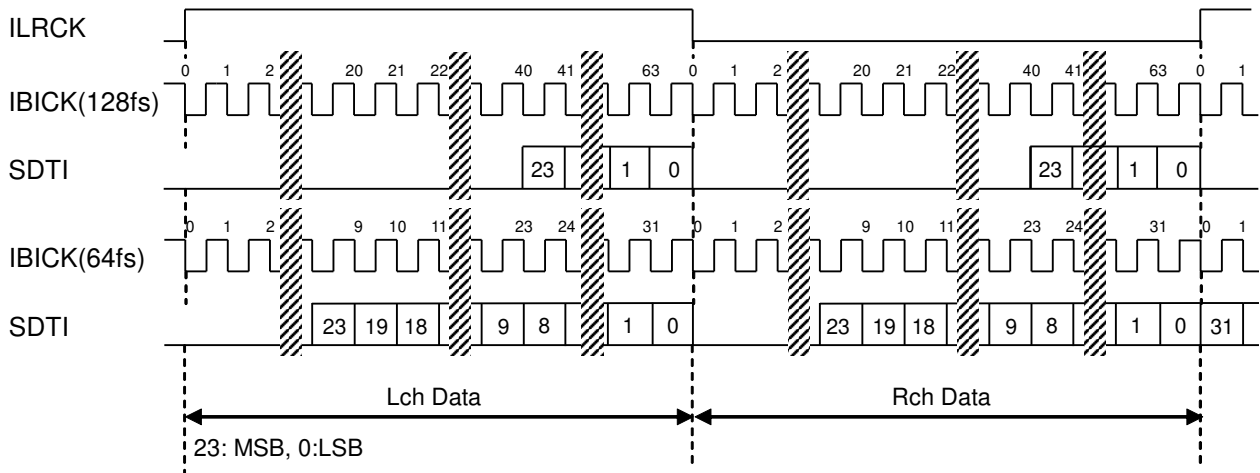

Figure 19. Mode1 Timing (24-bit LSB)

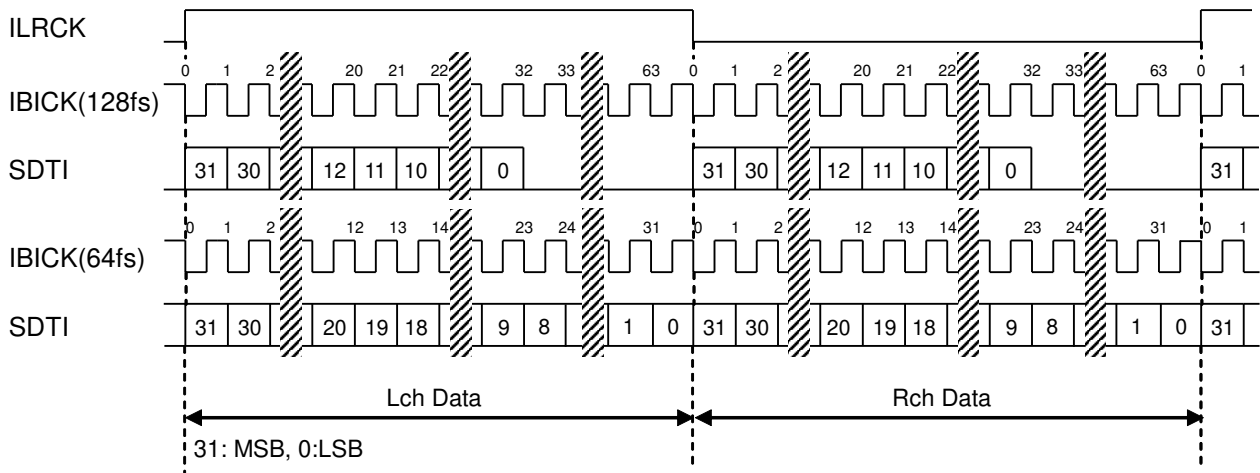

Figure 20. Mode2 timing (32-bit MSB)

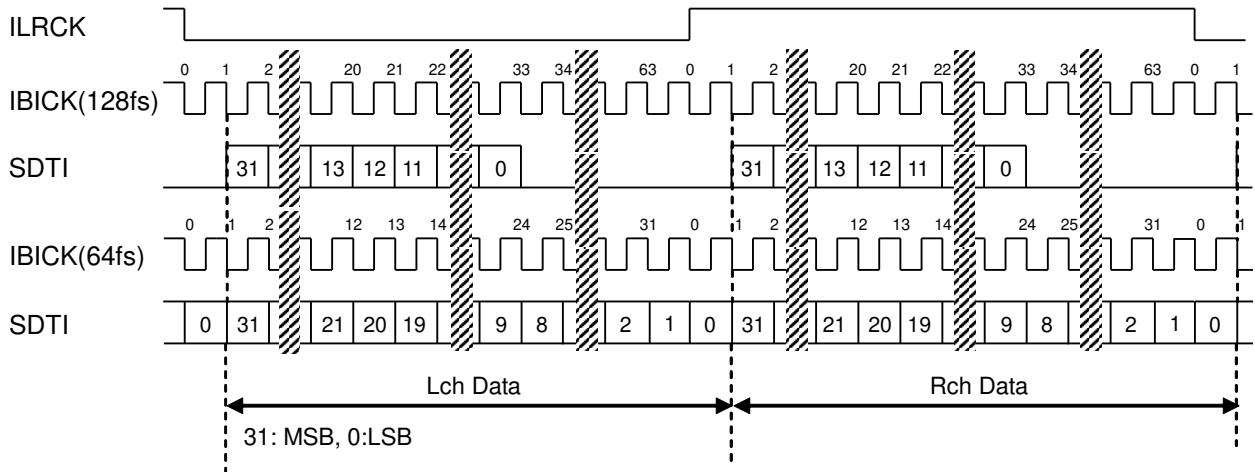

Figure 21. Mode3 Timing (32-bit I<sup>2</sup>S)

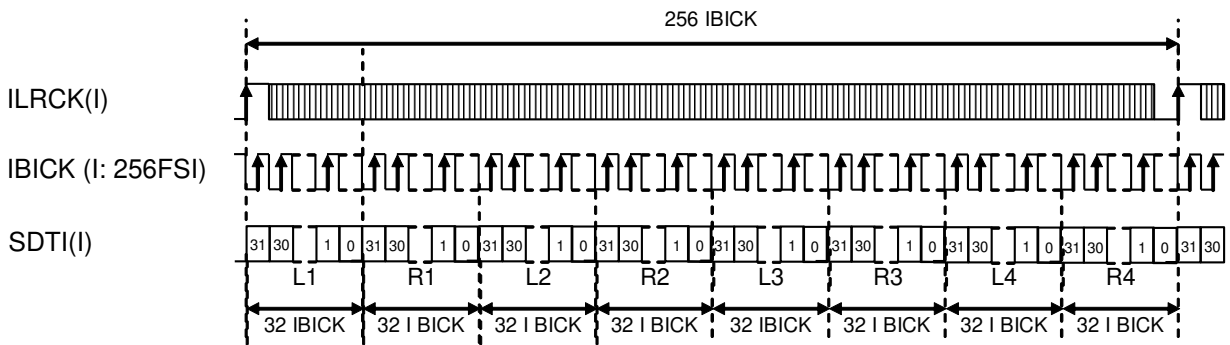

Figure 22. Mode4 Timing (32-bit MSB TDM256fs)

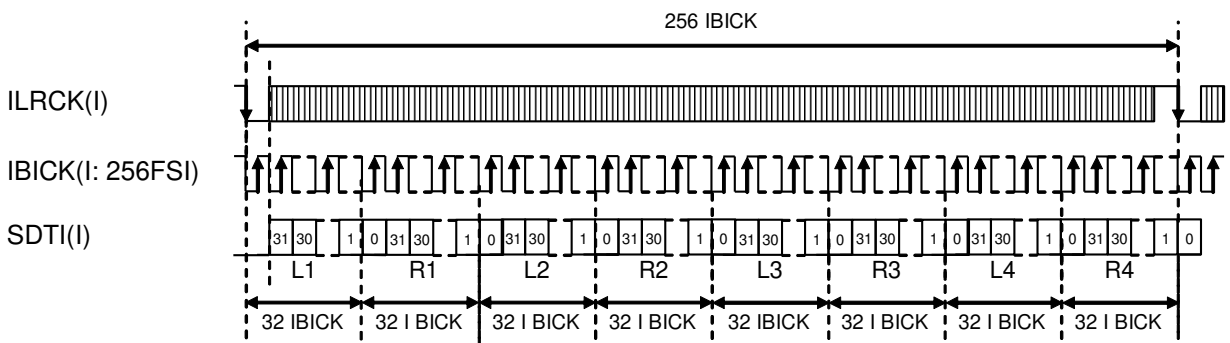

Figure 23. Mode5 Timing (32-bit I<sup>2</sup>S TDM256fs)

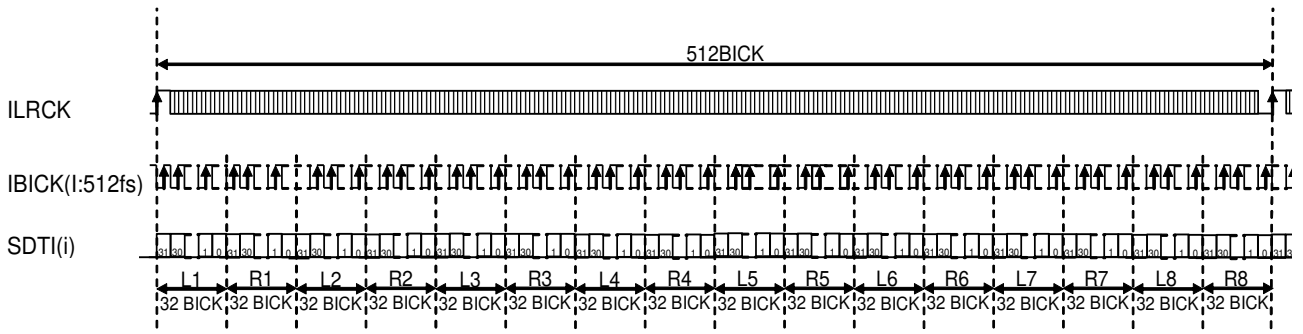

Figure 24. Mode6 Timing (32-bit MSB TDM512fs)

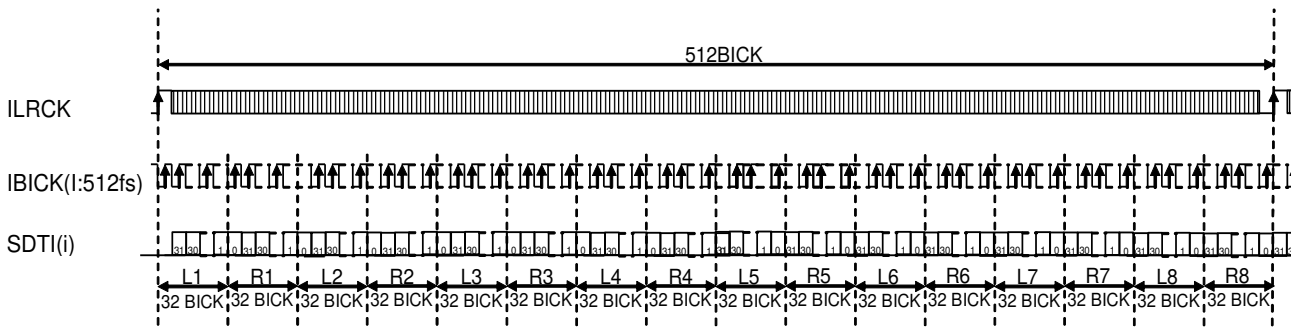

Figure 25. Mode7 Timing (32-bit I<sup>2</sup>S TDM512fs)

■ System Clock for Output PORT

The output ports work both in master and slave modes.

1. Slave Mode

Both OLRCK and OBICK pins are input when the AK4136 is in slave mode. Master clock is unnecessary.

2. Master Mode

Both OLRCK pin and OBICK pin are output when the AK4136 is in master mode. Master clock is supplied to the XTI/OMCLK/TDMI pin. The supplying method of Master clock is selected by CLKMODE pin.

Table 4. Master/Slave Mode Setting

Mode	OLRCK pin	OBICK pin	CLKMODE pin	XTI/OMCLK/TDMI pin	XTO pin
Slave Mode	Input	Input	Connect to DVSS	Connect to DVSS	OPEN
Master Mode	Output	Output	L	X'tal Input	X'tal Output
			H	External Clock Input	"L" Output

• X'tal Mode

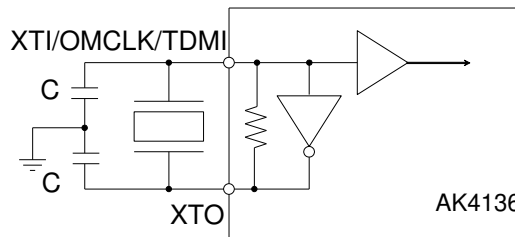

Note: Refer to Table 5 for the capacitor and resistance values for the X'tal oscillator.  
Figure 26. X'tal (XTI) Mode

Table 5. Equivalent Series Resistor and External Capacitor for External X'tal Oscillator

Normal Frequency [MHz]	11.2896	12.288	22.5792	24.576
Equivalent Series Resistance [ $\Omega$ ] max	60			
External Capacitor C[pF] max	15			

- In X'tal mode at 256FSO mode OMCLK input, FSO ranges from 44.1kHz to 96kHz.
- In X'tal mode at 384FSO mode OMCLK input, FSO ranges from 29.4kHz to 64kHz.
- In X'tal mode at 512FSO mode OMCLK input, FSO ranges from 22.05kHz to 48kHz.
- In X'tal mode at 768FSO mode OMCLK input, FSO ranges from 14.7kHz to 32kHz.
- In X'tal mode at 128FSO mode OMCLK input, FSO ranges from 88.2kHz to 192kHz.

• External Clock Mode

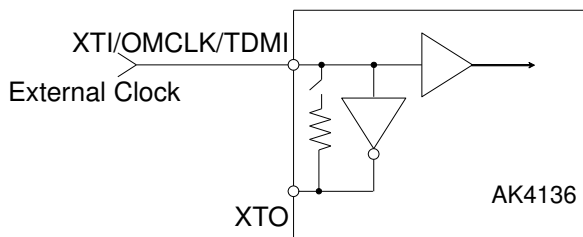

The XTO pin = "L" in External Clock mode.

Figure 27. External Clock (OMCLK) Mode

The CM2-0 pins select the master/slave mode and SRC bypass mode.

Table 6. Output PORT Master/Slave/ Bypass Mode Control (@Parallel Control Mode)

Mode	CM2 pin	CM1 pin	CM0 pin	Master / Slave	OMCLK Input (Note 19)	FSO
						PCM
0	L	L	L	Master	256FSO	8k ~ 192kHz
1	L	L	H	Master	384FSO	8k ~ 96kHz
2	L	H	L	Master	512FSO	8k ~ 96kHz
3	L	H	H	Master	768FSO	8k ~ 48kHz
4	H	L	L	Slave	Not used	8k ~ 384kHz
5	H	L	H	Master	128FSO	8k ~ 384kHz
6	H	H	L	Slave (Bypass)	Not used	-
7	H	H	H	Master (Bypass)		

Note 19. Use for a clock input or connect to DVSS.

In Mode 6-7, OMCLK/XTI input is ignored internally.

Table 7. Output PORT Master/Slave/ Bypass Mode Control (@Serial Control Mode)

Mode	CM2 pin	CM1 pin	CM0 pin	BYPSS bit	Master / Slave	OMCLK Input (Note 21)	FSO
							PCM
0	L	L	L	0	Master	256FSO	8k ~ 192kHz
1	L	L	H	0	Master	384FSO	8k ~ 96kHz
2	L	H	L	0	Master	512FSO	8k ~ 96kHz
3	L	H	H	0	Master	768FSO	8k ~ 48kHz
4	H	L	L	0	Slave	Not used. (Note 20)	8k ~ 384kHz
5	H	L	H	0	Master	128FSO	8k ~ 384kHz
6	H	H	L	0	Slave (Bypass)	Not used. (Note 20)	-
7	H	H	H	0	Master (Bypass)		
8	L	L	L	1	Master (Bypass)	Not used. (Note 20)	-
9	L	L	H	1	Master (Bypass)		
10	L	H	L	1	Master (Bypass)		
11	L	H	H	1	Master (Bypass)		
12	H	L	L	1	Slave (Bypass)		
13	H	L	H	1	Master (Bypass)		
14	H	H	L	1	Slave (Bypass)		
15	H	H	H	1	Master (Bypass)		

Note 20. Use for a clock input or connect to DVSS. Mode 6, 7, 8-15, OMCLK/XTI/TDMI input is ignored internally.

Note 21. In SRC mode, even if input port clocks ILRCK and IBICK are stopped, the AK4136 keeps outputting divided clock of the XTI/OMCLK/TDMI inputs if the device is in master mode and a clock input to the XTI/OMCLK/TDMI pin is supplied. In SRC bypass mode of master mode, ILRCK is input through and output from the OLRCK pin, and IBICK is input through and output from the OBICK pin. Therefore the OLRCK output will be stopped if ILRCK clock at the input port is stopped, and the OBICK will be stopped if IBICK clock at the input port is stopped.

## ■ Audio Interface Format for Output PORT

The ODIF1-0 pins and OBIT1-0 pins select the audio interface format for the output port. The audio data is MSB first, 2's complement format. The SDTO is clocked out on a falling edge of OBICK.

Select the audio interface format for output port while the PDN pin = "L". If the AK4136 is in slave mode at bypass mode, IBICK and OBICK must be synchronized but the phase is not critical. ILRCK and OLRCK must be synchronized but the phase is not critical. The audio interface format of SDTO is controlled by ODIF1-0 pins, OBIT1-0 pins and TDM pin.

Output ports become TDM mode when the TDM pin = "H". 6 channels or 14 channels serial data should be input to the XTI/OMCLK/TDMI pin. The SDTO pin outputs serial data for 8 channels or 16 channels. TDM mode is only available when the AK4136 is in slave mode.

Table 8. Output PORT Audio Interface Format 1

Mode	TDM	ODIF1	ODIF0	SDTO Format
0	L	L	L	LSB justified
1	L	L	H	I <sup>2</sup> S Compatible
2	L	H	L	MSB justified
3	L	H	H	I <sup>2</sup> S Compatible
4	H	L	L	TDM256 mode 32bit MSB justified
5	H	L	H	TDM256 mode 32bit I <sup>2</sup> S Compatible
6	H	H	L	TDM512 mode 32bit MSB justified
7	H	H	H	TDM512 mode 32bit I <sup>2</sup> S Compatible

Table 9. Output PORT Audio Interface Format 2

Mode	TDM pin	Master / Slave setting	OBIT1 pin	OBIT0 pin	SDTO pin	OLRCK	OBICK	OBICK Frequency	
								MSB justified, I <sup>2</sup> S	LSB justified
0	L	Slave (CM2-0 = "HLL"/"HHL")	L	L	32bit	Input	Input	≥ 64FSO	64FSO
1			L	H	24bit			≥ 48FSO	
2			H	L	20bit			≥ 40FSO	
3			H	H	16bit			≥ 32FSO	
4		Master (CM2-0 ≠ "HLL"/"HHL")	L	L	32bit	Output	Output	64FSO	
5			L	H	24bit				
6			H	L	20bit				
7			H	H	16bit				
8	H	Slave (CM2-0 = "HLL"/"HHL")	*	*	TDM mode 32bit	Input	Input	256FSO 512FSO	
9									
10									
11									

(\* The data length is fixed to 32 bits in TDM mode. The OBIT1-0 pin settings are ignored. Connect these pins to DVSS.)

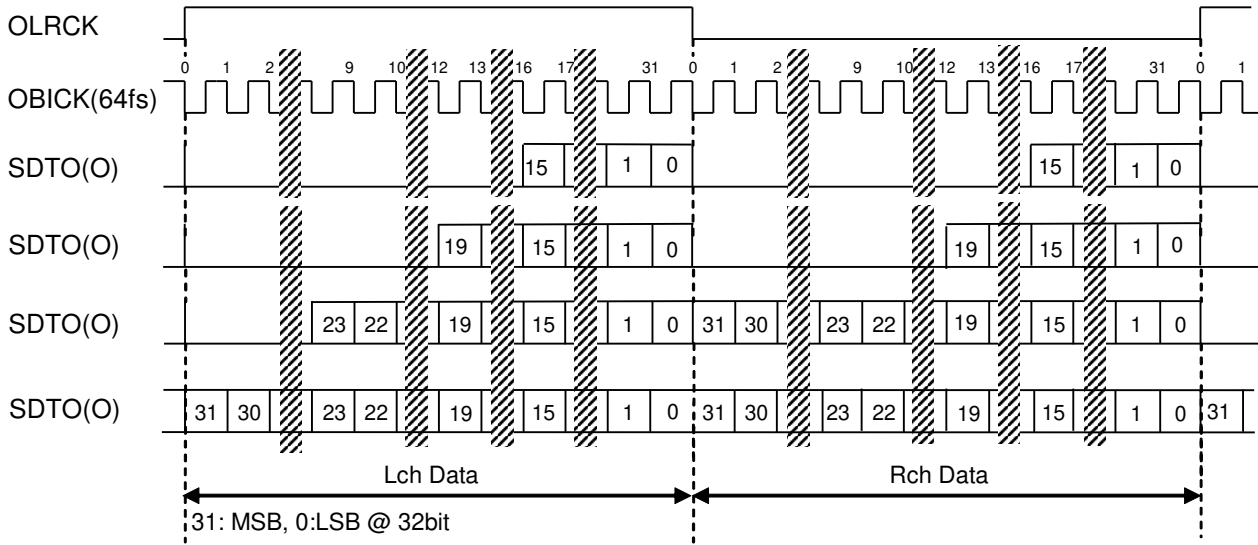

Figure 28. Stereo Mode LSB Justified Timing

(Except when the output port is Master (Bypass) Mode and the audio interface of the input port is TDM mode (24bit MSB justified or 24bit I<sup>2</sup>S Compatible))

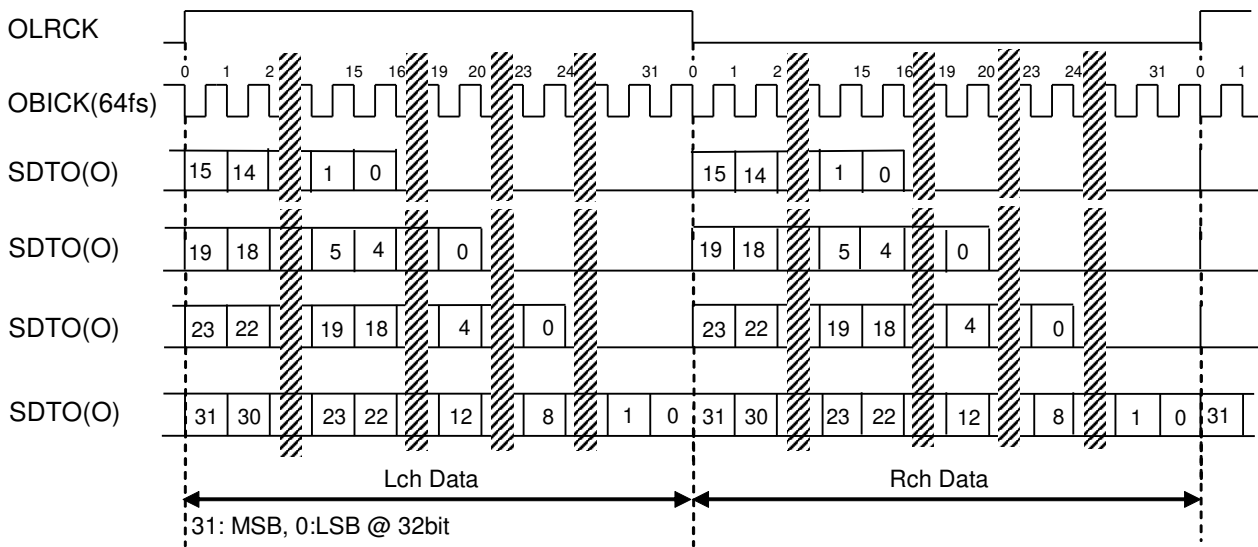

Figure 29. TDM 256 mode 32bit MSB Justified Timing at Slave Mode

(Except when the output port is Master (Bypass) Mode and the audio interface of the input port is TDM mode (24bit MSB justified or 24bit I<sup>2</sup>S Compatible))

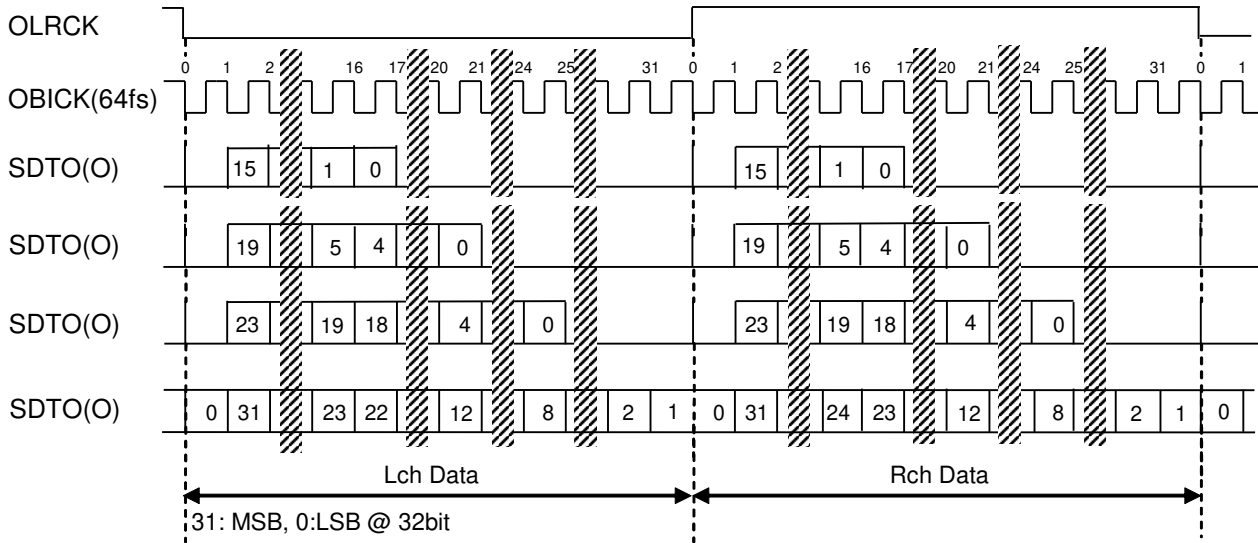

Figure 30. Stereo Mode I<sup>2</sup>S Compatible Timing

(Except when the output port is Master (Bypass) Mode and the audio interface of the input port is TDM mode (32bit MSB justified or 24bit I<sup>2</sup>S Compatible))

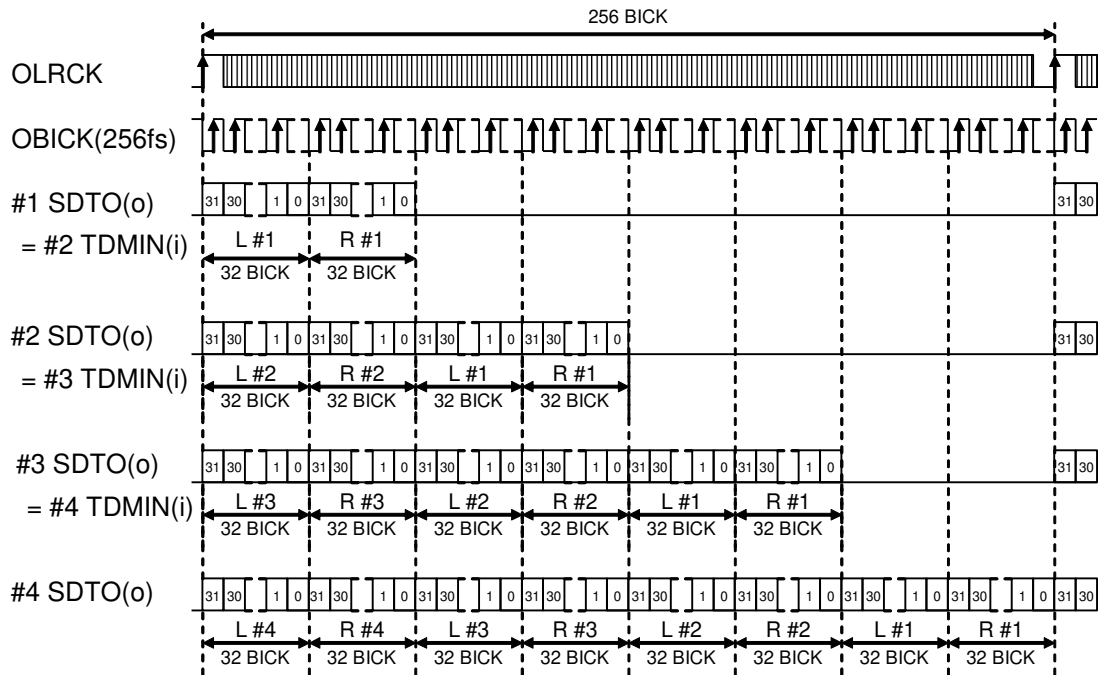

Figure 31. TDM 256 Mode 32bit MSB Justified Timing at Slave Mode



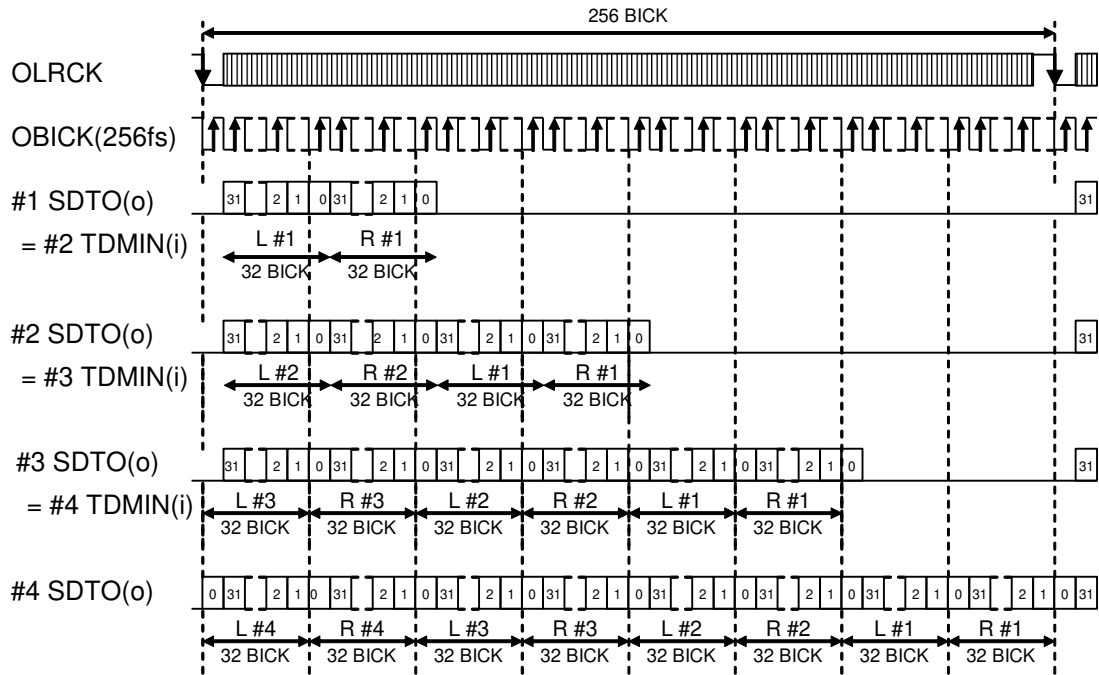

Figure 32. TDM 256 Mode 32bit I²S Compatible Timing at Slave Mode

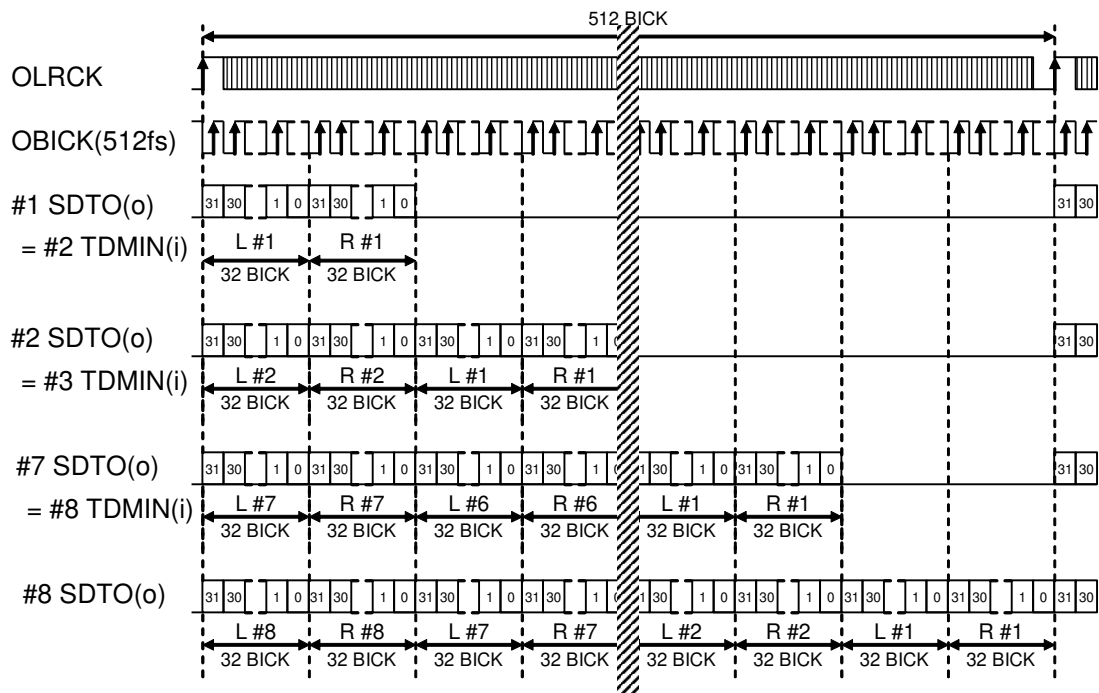

Figure 33. TDM 512 Mode 32bit MSB Justified Timing at Slave Mode

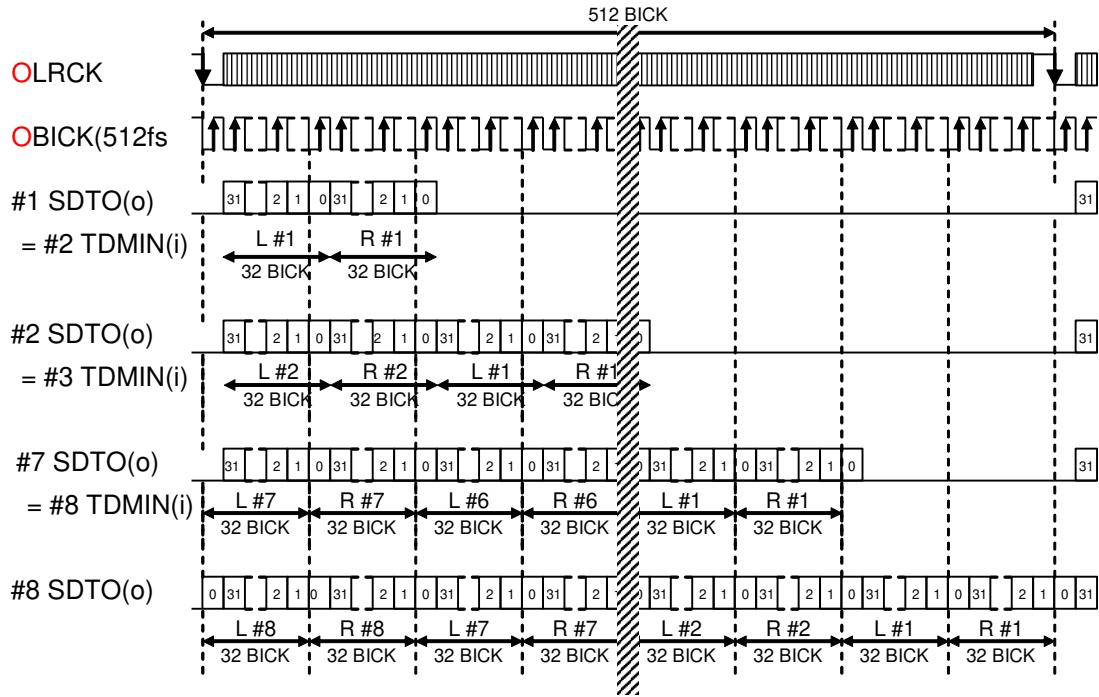

Figure 34. TDM 512 Mode 32bit I<sup>2</sup>S Compatible Timing at Slave Mode

■ Cascade Connection in TDM Mode

The AK4136 supports cascading of up to four devices (8 channels data) in a daisy chain configuration in TDM mode. In this mode, SDTO pin of device #1 is connected to OMCLK (TDMIN) pin of device #2. The SDTO pin of device #2 can output 4 channels of TDM data multiplexed with 2-channel of TDM data from device #1 and 2-channel of TDM data from device #2. Figure 35 shows a connection example of a daisy chain.

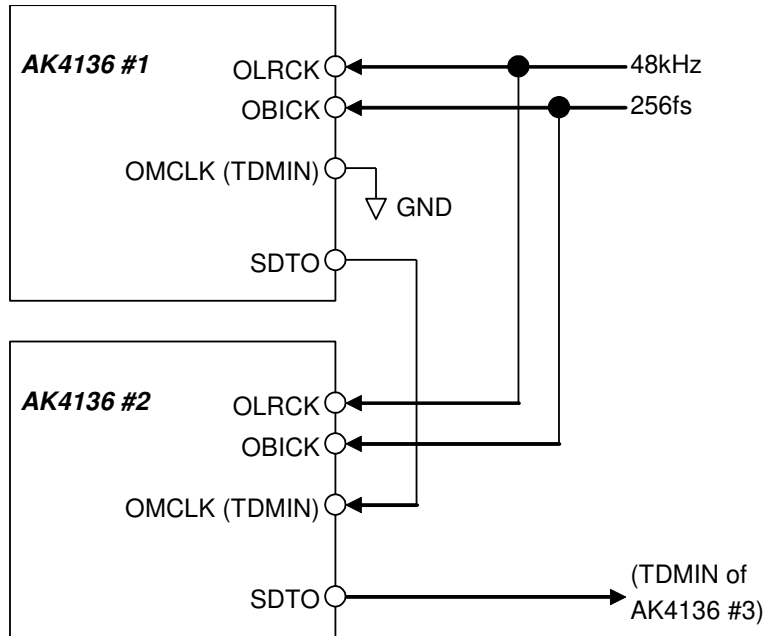

Figure 35. Cascade Connection Example

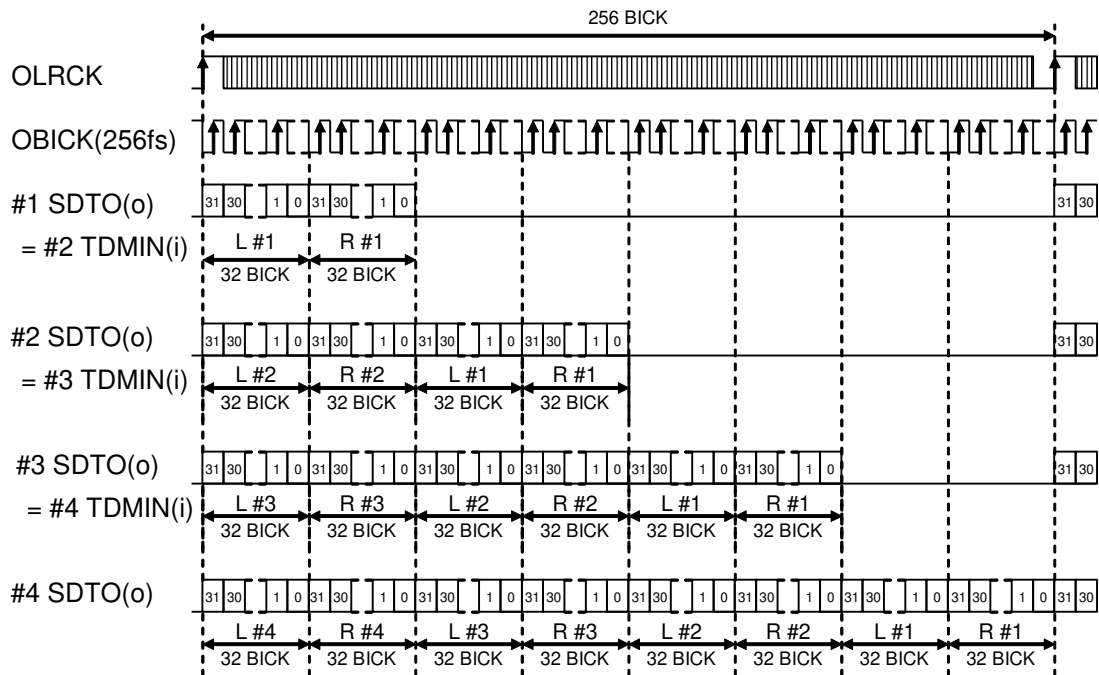

Figure 36. TDM Cascade

## ■ Soft Mute Function

### 1. Manual Mode

The soft mute operation is performed in the digital domain of the SRC output. SRC soft mute is controlled by the SMUTE pin in parallel control mode (PSN pin = "H") or SMUTE bit in serial control mode (PSN pin = "L"). The SRC output data is attenuated to  $-\infty$  in 1024 OLRCK cycles by setting SMUTE pin to "H" (or SMUTE bit = "1"). When setting the SMUTE pin to "L" (or SMUTE bit to "0"), the mute is cancelled and the output attenuation level gradually changes to 0dB in 1024 OLRCK cycles. If the soft mute is cancelled before attenuating to  $-\infty$ , the attenuation is discontinued and the attenuation level returns to 0dB by the same cycle. The soft mute is effective for changing the signal source without stopping the signal transmission. Soft mute cycle is set by SMT2-0 bits (PSN pin= "L"). The setting of SMT2-0 bits must not be changed during soft mute transition.

Table 10. Soft Mute Cycle Setting (PCM)

SMT2 bit	SMT1 bit	SMT0 bit	Period	fso=48kHz	fso=96kHz	fso=192kHz	fso=384kHz
0	0	0	1024/fso	21.3ms	10.7ms	5.3ms	2.7ms
0	0	1	2048/fso	42.7ms	21.3ms	10.7ms	5.3ms
0	1	0	4096/fso	85.3ms	42.7ms	21.3ms	10.7ms
0	1	1	8192/fso	170.7ms	85.3ms	42.7ms	21.3ms
1	0	0	16384/fso	341.3ms	170.7ms	85.3ms	42.7ms
1	0	1	32768/fso	682.7ms	341.1ms	170.7ms	85.3ms
1	1	0	reserved	-	-	-	-
1	1	1	reserved	-	-	-	-

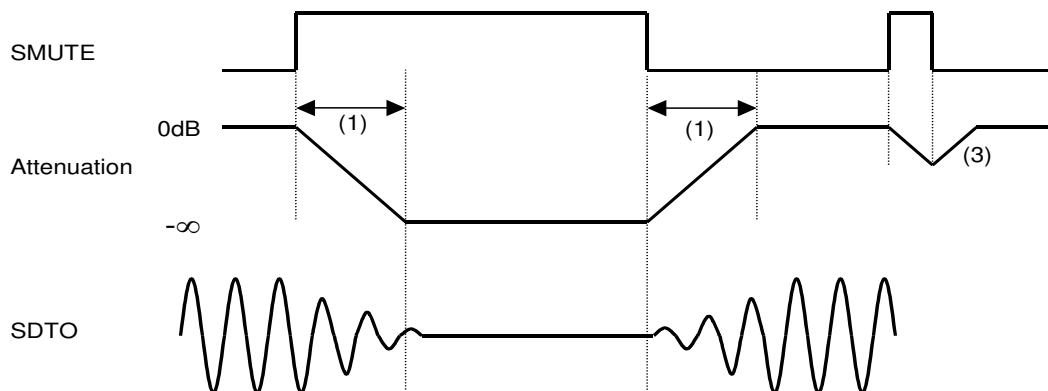

Figure 37. Soft Mute Manual Mode

1. Soft mute cycle is set by SMT2-0 bits (Table 10). The output data is attenuated to  $-\infty$  in the soft mute cycle.
2. If the soft mute is cancelled before attenuating to  $-\infty$ , the attenuation is discontinued and the attenuation level returns to 0dB by the same clock cycles.
3. If the soft mute is cancelled within the soft mute cycle after starting soft mute operation, the attenuation is discontinued and the attenuation level returns to 0dB by the same cycle.
4. The transition time can only be set by registers.

## 2. Semi-Auto Mode

The AK4136 enters Semi-auto Soft Mute mode by detecting reset release (RSTN bit="0"→"1") while the PSN pin="L" and SMUTE bit = "1".

The soft mute is cancelled automatically in  $4410/F_{SO}=100\text{ms}$  @ $F_{SO}=44.1\text{kHz}$  after detecting a rising edge of the RSTN bitn = "0" → "1". Soft mute will not be cancelled if the SMUTE bit is "1" after reset is released. The setting of SMSEMI bit must be changed during RSTN bit = "0".

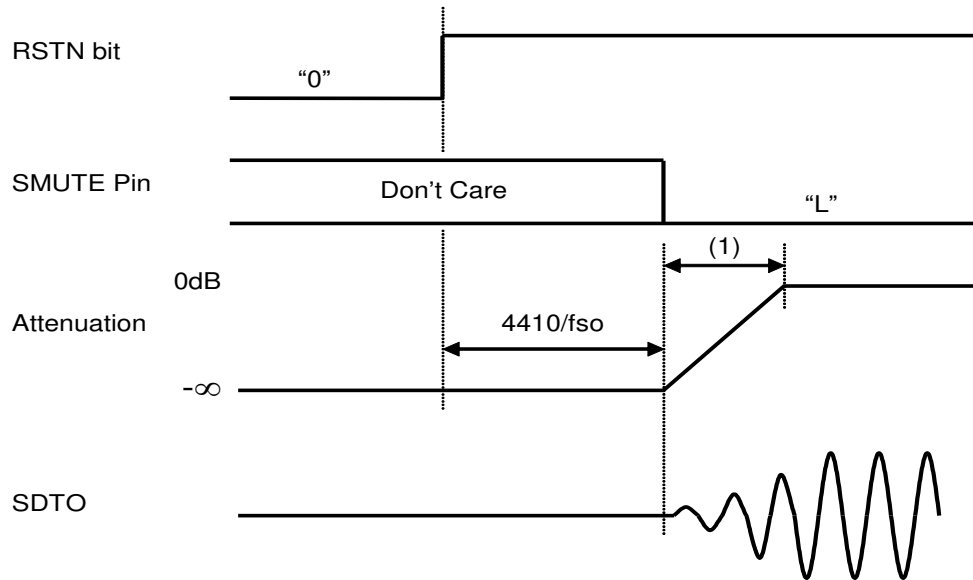

Figure 38. Soft Mute Semi-Auto Mode

- (1) The output data is attenuated by  $-\infty$  during the soft mute cycle (Table 10). (only When the SMUTE pin="L". When the SMUTE pin="H", the output data is kept muted.)
- (2) When the attenuation level is 0dB by a soft mute release after  $4410/F_{SO}$ , the output signal is able to mute or release mute by the soft mute cycle (Table 10).

### ■ Dither Circuit

The AK4137 includes a dither circuit. The dither circuit adds a dither signal after the lowest bit of all the output data set by the OBIT1-0 pins when DITHER bit = "1", regardless of SRC and SRC bypass modes. If the output data has 32-bit length in SRC bypass mode, the output code will not be affected by the DITHER bit setting.

## ■ Digital Filter

The AK4136 has four kinds of digital filters and they are selected by the SD pin and the SLOW pin in parallel control mode (PSN pin = "H").

In serial control mode (PSN pin = "L"), the SD pin and the SLOW pin becomes the SCLK/CCLK pin and the SDA/CDTI pin, respectively and the filter setting by these pins are ignored.

Table 11. Digital Filter Setting (@Parallel Control Mode)

SD pin	SLOW pin	Mode
L	L	Sharp roll-off filter
L	H	Slow roll-off filter
H	L	Short delay Sharp roll-off filter
H	H	Short delay Slow roll-off filter

Table 12. Digital Filter Setting (@Serial Control Mode)

SD bit	SLOW bit	Mode
0	0	Sharp Roll-off Filter
0	1	Slow Roll-off Filter
1	0	Short delay Sharp Roll-off Filter
1	1	Short delay Slow Roll-off Filter

(default)

## ■ De-emphasis Filter

In serial control mode (PSN pin = "L"), de-emphasis setting of the SRC is controlled by DEM1-0 bits. In parallel control mode (PSN pin = "H"), DEM1-0 bits setting is invalid and de-emphasis setting of the SRC is controlled by DEM1-0 pins.

Table 13. De-emphasis Filter Setting

DEM1bit	DEM0 bit	Mode
0	0	44.1kHz
0	1	OFF
1	0	48kHz
1	1	32kHz

## ■ Regulator

The AK4136 has an internal regulator which suppresses the voltage to 1.8V from DVDD. The generated 1.8V power is used as power supply for internal circuits only. When an over-current flows into the regulator output, over-current detection circuit will work. When an over-voltage flows into the regulator output, over-voltage detection circuit will work. The regulator block is powered-down and the AK4136 becomes reset state when over-current detection or over-voltage detection is executed. The AK4136 does not return to normal operation without a reset by the PDN pin when these detection circuits are worked. When over-current or over-voltage is detected, the PDN pin should be brought into "L" at once, and set to "H" again to recover normal operation.

The SRCEN pin indicates the internal status of the device. It outputs "L" in SRC normal operation and outputs "H" when over-current or over-voltage is detected.

■ System Reset

Bringing the PDN pin = “L” sets the AK4136 power-down mode and initializes digital filters. The AK4136 should be reset once by bringing the PDN pin = “L” upon power-up. When the PDN pin is “L”, the SDTO output is “L”. It takes 32ms (max) to output SDTO data after power-down state is released by a clock input. Until then, the SDTO pin outputs “L”. The internal SRC circuit is powered up on an edge of ILRCK after the internal regulator is powered up.

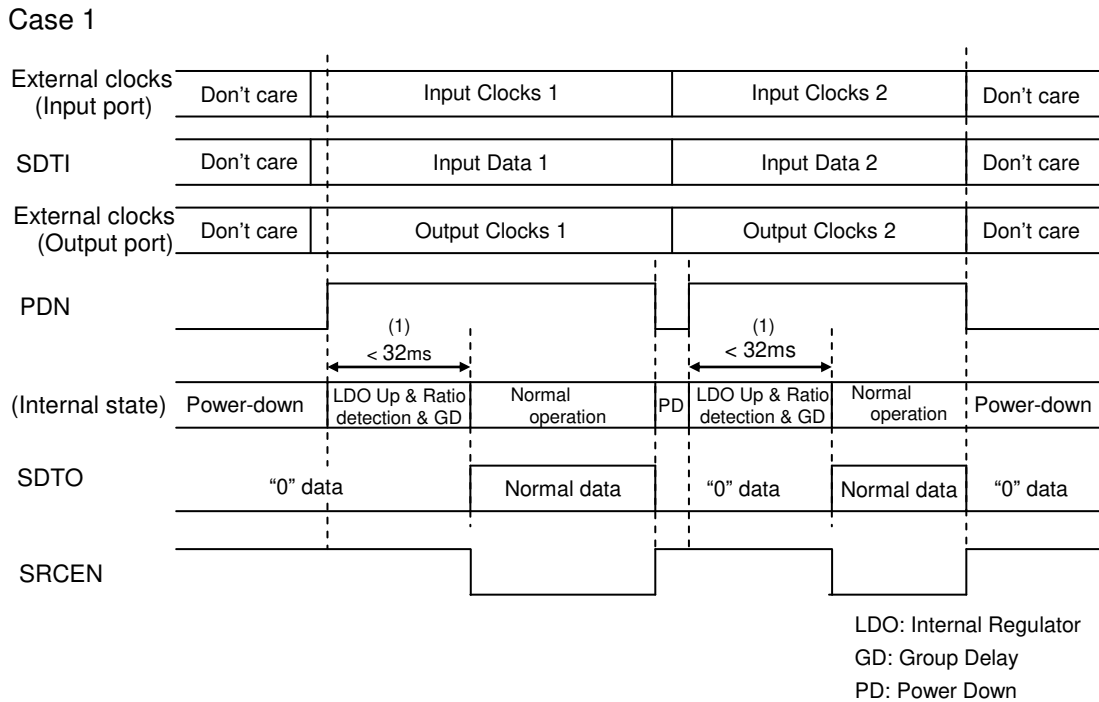

Figure 39. System Reset 1

The setting of the PSN, CM2-0, OBIT1-0, TDM, ODIF1-0, IDIF2-0, CAD1-0 pins must be changed while the PDN pin is “L”. The SRCEN pin outputs “H” during “L” period of the PDN pin. If the internal regulator is normal operation and ratio detection is completed, SRC data is output from the SDTO pin after a rising edge of the PDN pin.

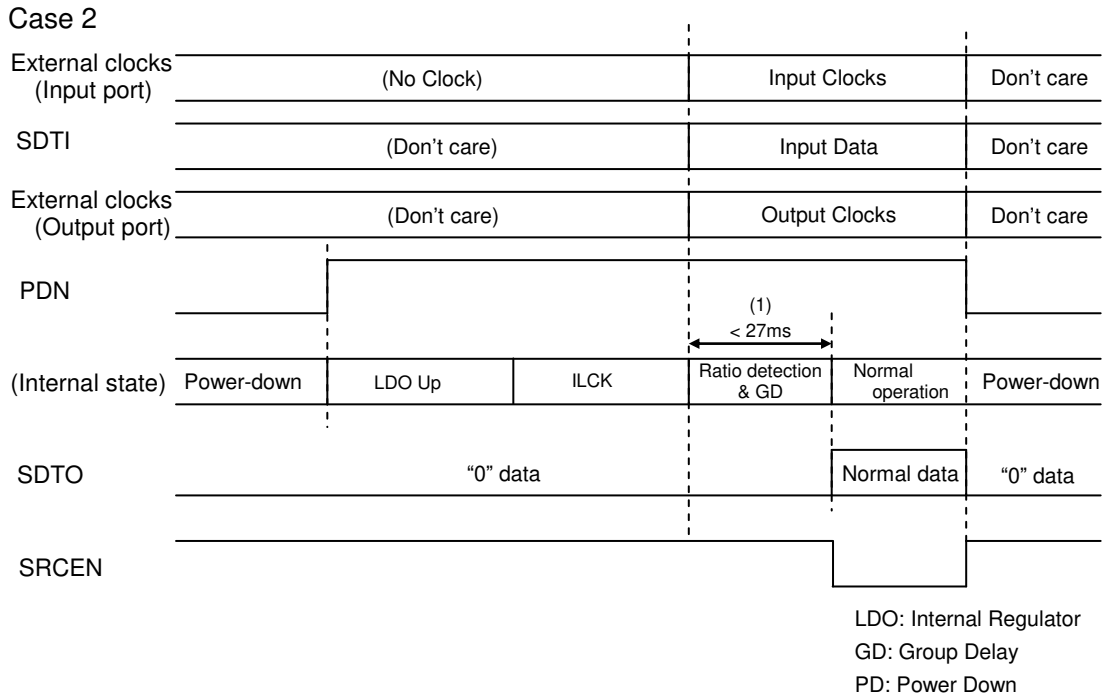

Figure 40. System Reset 2

■ Internal Reset Function for Clock Change

Clock change timing is shown in Figure 41 and Figure 42. When changing the clock, the AK4136 should be reset by the PDN pin in parallel control mode and it should be reset by the PDN pin or RSTN bit in serial control mode.

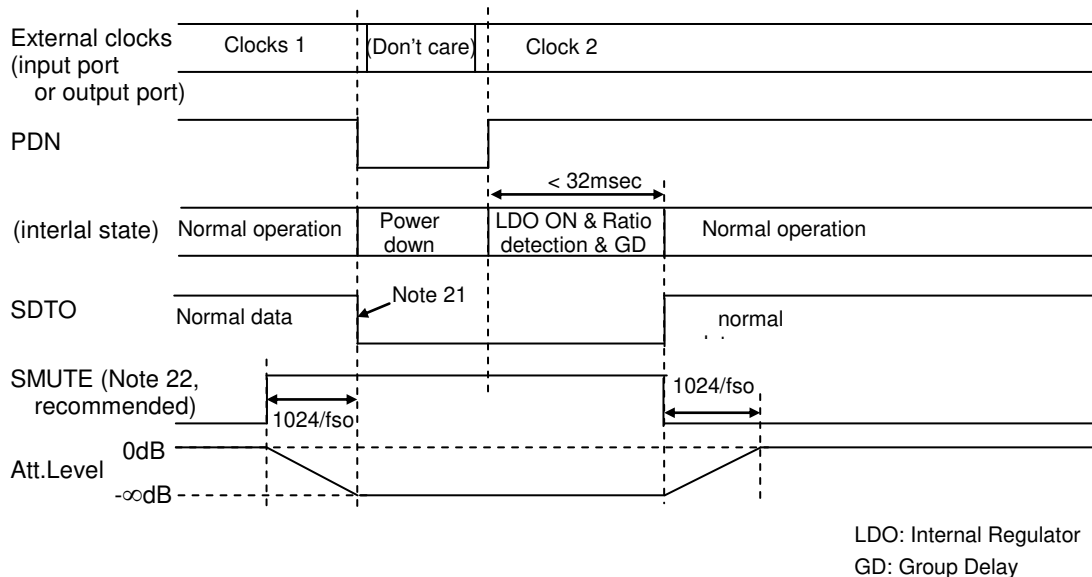

Figure 41. Sequence of Changing Clocks (Parallel Control Mode, PSN pin="H")

Note 22. The data on SDTO may cause a clicking noise. To prevent this, set "0" to the SDTI more than  $1024/fs$  (GD) before the PDN pin changes to "L". It makes the data on SDTO remain as "0".

Note 23. SMUTE can also remove the clicking noise (Note 22).



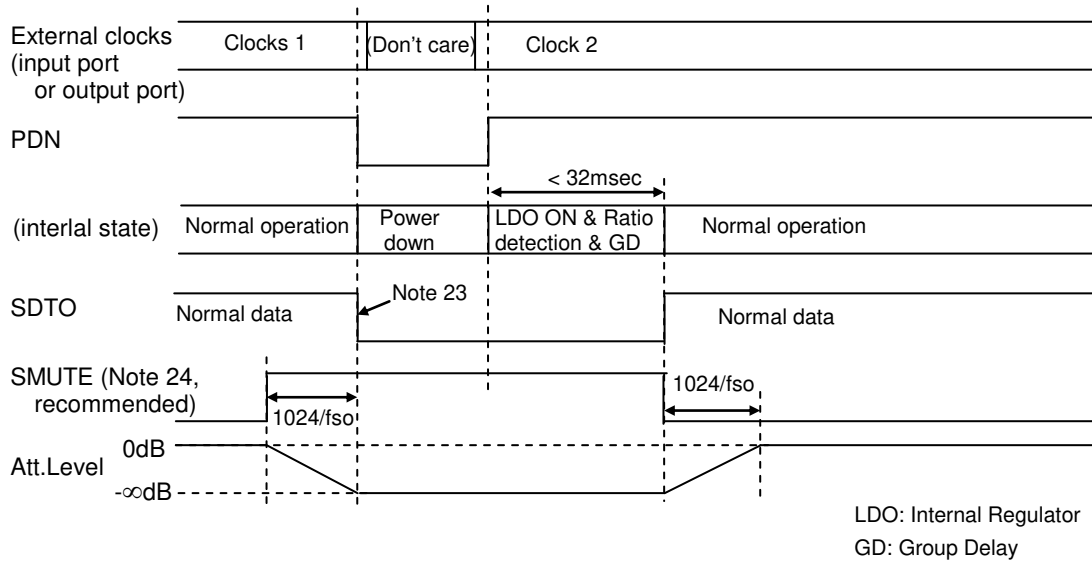

Figure 42. Sequence of Changing Clocks (Serial Control Mode, PSN pin= "L")

- Note 24. The data on SDTO may cause a clicking noise. To prevent this, set "0" to the SDTI more than  $1024/f_s$  (GD) before the PDN pin changes to "L". It makes the data on SDTO remain as "0".
- Note 25. SMUTE can also remove the clicking noise (Note 24).
- Note 26. The digital block except serial control interface and registers is powered-down. The internal oscillator and regulator are not powered-down.
- Note 27. It is the total time of  $0.5/FSI+8/FSI(O)+204/FSO$  or  $1.5/FSI+8/FSI(O)+204/FSO$ . (FSI(O) is lower frequency between FSI and FSO)

### ■ When the Frequency of ILRCK at Input Port Is Changed Without A Reset by The PDN Pin or RSTN Bit

When the difference of internal oscillator clock number in one ILRCK cycle between before ILRCK frequency is changed (FSO/FSI ratio is stabilized) and after the change is more than 1/16 for 8 cycles, an internal reset is made automatically and sampling frequency ratio detection is executed again. SDTO outputs "L" when the internal reset is made, and SRC data is output after "214/FSO" (FSI(O) is lower frequency between FSI and FSO).

If the difference of internal oscillator clock number in one ILRCK cycle between before ILRCK frequency is changed and after the change is less than 1/16 or more than 1/16 but shorter than 8 cycles, the internal reset is not executed. In both cases; when ILRCK frequency is changed immediately without transition time or with transition time which is not long enough for an internal reset, it takes 5148/FSO\*\* (max. 643.5ms PCM Output @FSO=8kHz) to output normal SRC data. Distorted data may be output until normal SRC output.

When ILRCK is stopped, an internal reset is executed automatically. It takes "214/FSO" [s] to output normal SRC data after ILRCK is input again (FSI(O) is lower frequency between FSI and FSO).

### ■ When the Frequency of OLRCK at Output Port Is Changed Without A Reset by The PDN Pin or RSTN Bit

When the difference of internal oscillator clock number in one OLRCK cycle between before OLRCK frequency is changed (FSO/FSI ratio is stabilized) and after the change is more than 1/16 for 8 cycles, an internal reset is made automatically and sampling frequency ratio detection is executed again. SDTO outputs "L" when the internal reset is made, and SRC data is output after "214/FSO" (FSI(O) is lower frequency between FSI and FSO).

If the difference of internal oscillator clock number in one OLRCK cycle between before an OLRCK frequency change and after the change is less than 1/16 or more than 1/16 but shorter than 8 cycles, the internal reset is not executed. It takes 5148/FSO\*\* (max. 643.5ms PCM output @FSO=8kHz) to output normal SRC data. Distorted data may be output until normal SRC output.

When OLRCK is stopped, an internal reset is executed automatically. It takes "214/FSO" [s] to output normal SRC data after ILRCKx is input again.

\*\* When FSO=8kHz and FSO/FSI ratio is changed from 1/6 to 1/5.99. It is 160.9ms when FSO=32kHz and FSO/fSI ratio is changed from 1/6 to 1/5.99.

### ■ Pop Noise Reduction in Sampling Rate Conversion

When ILRCK and OLRCK frequencies of the input port are changed without a reset by the PDN pin or RSTN bit, the output signal is soft muted automatically if internal reset is executed by ASCHON bit = "1". Soft mute time is the setting value shown in [Table 10](#).

## ■ Internal Status Pin

The SRCEN pin indicates internal status of the device. This pin outputs “H” when the PDN pin = “L”. SRC data is output from the SDTO pin, which corresponds to the each sampling frequency ratio detected SRC, after a rising edge “↑” of PDN if the internal regulator is in normal operation.

When an over-current/voltage flows into the internal regulator, the SRCEN pin outputs “H”. An OR’ed result of the flags between over-current/voltage detection at the internal regulator and SRC sampling frequency detection complete is output from this pin.

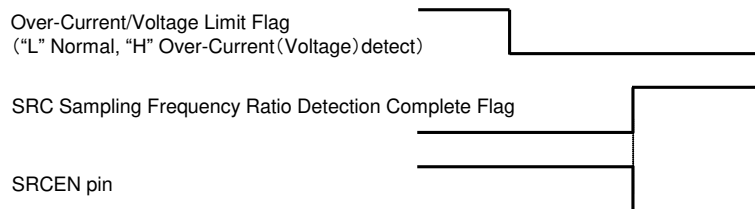

Figure 43. Internal Flags and SRCEN pin Output

In parallel control mode, if the AK4136 is set in SRC bypass mode by CM2-0 pins during the PDN pin = “L” and powered-up, the SRCEN pin outputs “L” after the power-up time of the internal regulator (max. 5ms) from a rising edge “↑” of the PDN pin.

In serial control mode, if BYPS bit is set to “1” while RSTN bit = “0”, the SRCEN pin immediately outputs “L” after register writing.

■ Serial Control Interface

The AK4136 becomes serial control mode by setting the PSN pin to “L”. The AK4136 supports 4-wire serial Interface (I2S pin = “L”) and I2C bus (I2S pin = “H”) modes for internal register accessing.

1. 4-wire Serial Control Mode (I2C pin = “L”)

The internal registers may be written by the 4-wire  $\mu$ P interface pins: CSN, CCLK and CDTI. The data on this interface consists of Chip address (2bits, C1/0), Read/Write (Write= “1”, Read= “0”), Register address (MSB first, 5bits) and Control data (MSB first, 8bits). Address and data are clocked in on the rising edge of CCLK and data is clocked out on the falling edge. Data write becomes available by a rising edge of CSN pin. For read operations, the CDTO output goes high impedance after a low-to-high transition of CSN. The maximum speed of CCLK is 5MHz. Internal register values are initialized by setting the PDN pin to “L”. The internal register timing circuit is reset by setting RSTN bit to “0” in serial control mode. In this case, the register values are not initialized.

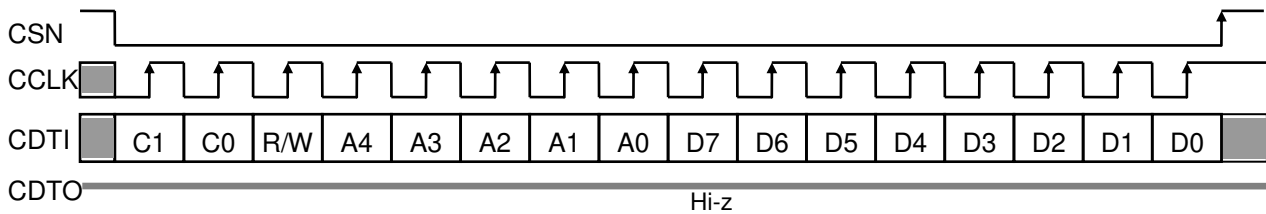

Figure 44. Write Operation

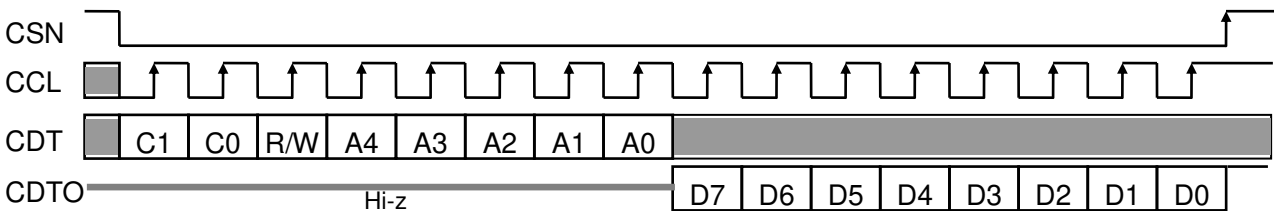

Figure 45. Read Operation

- C1-C0: Chip Address (C1 bit =CAD1 pin, C0 bit =CAD0 pin)
- R/W: READ/WRITE (Write=“1”, Read=“0”)
- A4-A0: Register Address
- D7-D0: Control Data

## 2. I<sup>2</sup>C-bus Control Mode (I<sup>2</sup>C pin = “H”)

The AK4136 supports High speed mode I<sup>2</sup>C-bus (max: 400kHz)

### 2-1. WRITE Operation

Figure 46 shows the data transfer sequence of the I<sup>2</sup>C-bus mode. All commands are preceded by START condition. A HIGH to LOW transition on the SDA line while SCL is HIGH indicates START condition (Figure 52). After the START condition, a slave address is sent. This address is 7 bits long followed by the eighth bit that is a data direction bit (R/W). The most significant five bits of the slave address are fixed as “00100”. The next 6th and 7th bits are CAD0/CAD1(device address bit). This bit identifies the specific device on the bus. The hard-wired input pin (CAD0/CAD1 pin) set these device address bits. If the slave address matches that of the AK4136, the AK4136 generates an acknowledge and the operation is executed. The master must generate the acknowledge-related clock pulse and release the SDA line (HIGH) during the acknowledge clock pulse (Figure 53). R/W bit = “1” indicates that the read operation is to be executed. “0” indicates that the write operation is to be executed.

The second byte consists of the control register address of the AK4136. The format is MSB first, and those most significant 3-bits are fixed to zeros (Figure 48). The data after the second byte contains control data. The format is MSB first, 8bits (Figure 49). The AK4136 generates an acknowledge after each byte is received. Data transfer is always terminated by STOP condition generated by the master. A LOW to HIGH transition on the SDA line while SCL is HIGH defines STOP condition (Figure 52).

The AK4136 can execute multiple one byte write operations in a sequence. After receipt of the third byte the AK4136 generates an acknowledge and awaits the next data. The master can transmit more than one byte instead of terminating the write cycle after the first data byte is transferred. After receiving each data packet the internal 6-bit address counter is incremented by one, and the next data is automatically taken into the next address. If the address exceeds 02H prior to generating a stop condition, the address counter will “roll over” to 00H and the previous data will be overwritten.

The data on the SDA line must remain stable during the HIGH period of the clock. The HIGH or LOW state of the data line can only change when the clock signal on the SCL line is LOW (Figure 54) except for the START and STOP conditions.

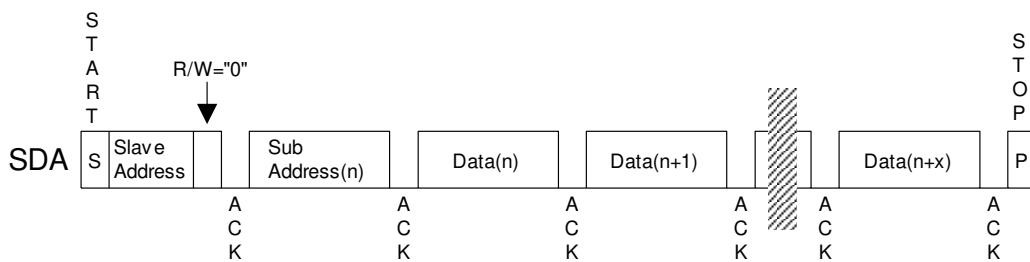

Figure 46. Data Transfer Sequence at the I<sup>2</sup>C-Bus Mode

0	0	1	0	0	CAD1	CAD0	R/W
---	---	---	---	---	------	------	-----

Figure 47. The First Byte

0	0	0	A4	A3	A2	A1	A0
---	---	---	----	----	----	----	----

Figure 48. The Second Byte

D7	D6	D5	D4	D3	D2	D1	D0
----	----	----	----	----	----	----	----

Figure 49. Byte Structure after the second byte

## 2-2. READ Operation

Set the R/W bit = "1" for the READ operation of the AK4136. After transmission of data, the master can read the next address's data by generating an acknowledge instead of terminating the write cycle after the receipt of the first data word. After receiving each data packet the internal 6-bit address counter is incremented by one, and the next data is automatically taken into the next address. If the address exceeds 02H prior to generating stop condition, the address counter will "roll over" to 00H and the data of 00H will be read out.

The AK4136 supports two basic read operations: Current Address Read and Random Address Read.

### 2-2-1. Current Address Read

The AK4136 contains an internal address counter that maintains the address of the last word accessed, incremented by one. Therefore, if the last access (either a read or write) was to address "n", the next CURRENT READ operation would access data from the address "n+1". After receipt of the slave address with R/W bit "1", the AK4136 generates an acknowledge, transmits 1-byte of data to the address set by the internal address counter and increments the internal address counter by 1. If the master does not generate an acknowledge but generates a stop condition instead, the AK4136 discontinues transmission.

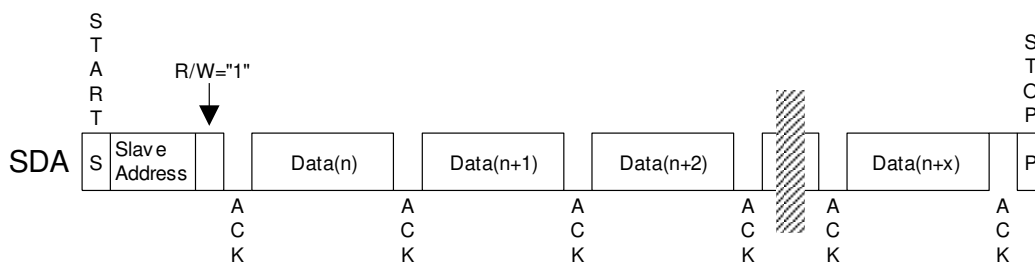

Figure 50. Current Address Read

### 2-2-2. Random Address Read

The random read operation allows the master to access any memory location at random. Prior to issuing a slave address with the R/W bit = "1", the master must execute a "dummy" write operation first. The master issues a start request, a slave address (R/W bit = "0") and then the register address to read. After the register address is acknowledged, the master immediately reissues the start request and the slave address with the R/W bit = "1". The AK4136 then generates an acknowledge, 1 byte of data and increments the internal address counter by 1. If the master does not generate an acknowledge but generates a stop condition instead, the AK4136 discontinues transmission.

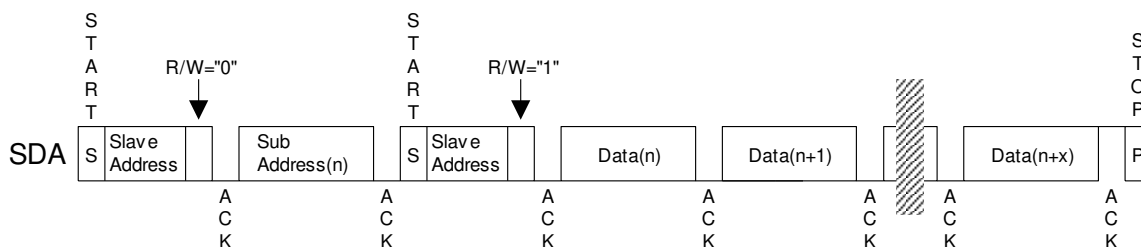

Figure 51. Random Address Read

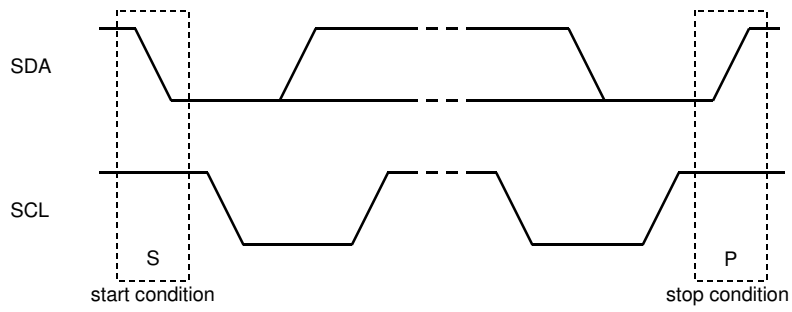

Figure 52. START and STOP Conditions

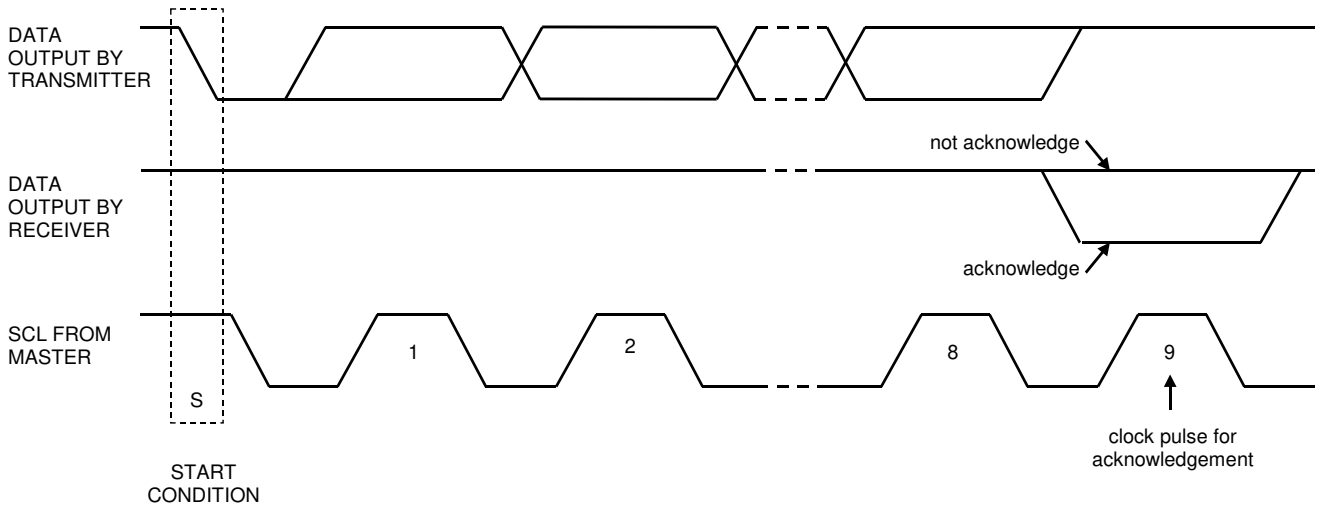

Figure 53. Acknowledge on the I<sup>2</sup>C-Bus

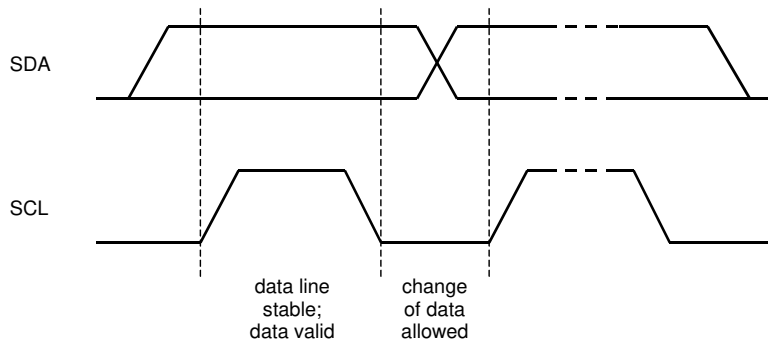

Figure 54. Bit Transfer on the I<sup>2</sup>C-Bus

The pull-up resistance of SCL and SDA pins should be connected below the voltage of DVDD+0.3V.

## ■ Register Map

Addr	Register Name	D7	D6	D5	D4	D3	D2	D1	D0	default
00H	Reset & Mute	SMSEMI	SMT2	SMT1	SMT0	SMUTE	BYPS	FORCE STB	RSTN	0x01
01H	PCMCONT0	SLOW	SD	DEM1	DEM0	DITHER	IDIF2	IDIF1	IDIF0	0x12
02H	PCMCONT1	0	0	0	0	ASCHON	TDMICH2	TDMICH1	TDMICH0	0x00

Note 28. Register values are initialized by setting the PDN pin to “L”.

Note 29. Writing to the address except 00H ~ 02H is prohibited. The bits defined as 0 must contain a “0” value.

Note 30.  $\mu$ P interface access becomes valid 5ms (max) after from the PDN pin “ $\uparrow$ ”.



## ■ Register Definitions

Addr	Register Name	D7	D6	D5	D4	D3	D2	D1	D0
00H	Reset & Mute	SMSEMI	SMT2	SMT1	SMT0	SMUTE	BYP	FORCE STB	RSTN
	R/W	R/W	R/W	R/W	R/W	R/W	R/W	R/W	R/W
	Default	0	0	0	0	0	0	0	1

SMSEMI: Semi Auto Soft Mute

0: Semi Auto Soft Mute Off (default)

1: Semi Auto Soft Mute ON

SMT2-0: Soft Mute Period

000: 1024/fso (default)

001: 2048/fso

010: 4096/fso

011: 8192/fso

100: 16384/fso

101: 32768/fso

110: reserved

111: reserved

Soft Mute Cycle is determined.

SMUTE: Soft Mute Control

0: Soft Mute Release (default)

1: Soft Mute

In Serial Control Mode (PSN pin = "L"), the CSN/SMUTE pin functions as the CSN pin, and SMUTE setting is ignored. In Parallel Control Mode (PSN pin = "H"), the SMUTE pin setting is valid.

BYP: Bypass Mode Control ([Table 7](#))

0: SRC Mode (default)

1: SRC Bypass Mode

FORCESTB: CLKSTABLE signal (Checking signal for IRCK and OLRCK changes) is set to "1" forcibly.

0: Normal Operation (default)

1: CLKSTABLE = "1"

RSTN: Digital Reset Control

0: Reset

1: Reset Release (default)

Digital blocks are powered down by setting RSTN bit = "0". However, I<sup>2</sup>C serial control interface and control register blocks are not powered down, and control register values are not initialized. In this case, control register writing is also available. Internal oscillator that generates internal clock, regulator and reference voltage generation circuits are not powered down.

Addr	Register Name	D7	D6	D5	D4	D3	D2	D1	D0
01H	PCMCONT0	SLOW	SD	DEM1	DEM0	DITHER	IDIF2	IDIF1	IDIF0
	R/W	R/W	R/W	R/W	R/W	R/W	R/W	R/W	R/W
	Default	0	0	0	1	0	0	1	0

**SLOW: FIR1 Filter Coefficient Select**

0: Sharp Roll OFF Filter (default)

1: Slow Roll OFF Filter

In Serial Control Mode (PSN pin = "L"), the SDA/CDTI/SLOW pin functions as SDA/CDTI pin and SLOW setting is ignored.

In Parallel Control Mode (PSN pin = "H"), the SLOW pin setting is valid.

**SD: FIR1 Filter Coefficient Select**

0: Normal Delay Filter (default)

1: Short Delay Filter

In Serial Control Mode (PSN pin = "L"), the SCL/CCLK/SD pin functions as SCL/CCLK pin and SD setting is ignored.

In Parallel Control Mode (PSN pin = "H"), the SD pin setting is valid.

**DEM1, DEM0: De-emphasis Control**

00: 44.1kHz

01: OFF (default)

10: 48kHz

11: 32kHz

**DITHER: Dither is added.**

0: DITHER OFF (default)

1: DITHER ON

**IDIF2, IDIF1, IDIF0: Audio Interface Mode Select for Input Port (Table 3)**

000: 32bit, LSB justified

001: 24bit, LSB justified

010: 32bit, MSB justified (default)

011: 32 or 16bit, I2S justified

100: TDM 32bit, MSB justified

101: TDM 32bit, I2S Compatible

110: TDM 32bit, MSB justified

111: TDM 32bit, I2S Compatible

In Parallel Control Mode (PSN pin = "H"), IDIF2-0 bits settings are valid.

Addr	Register Name	D7	D6	D5	D4	D3	D2	D1	D0
02H	PCMCONT1	0	0	0	0	ASCHON	TDMICH2	TDMICH1	TDMICH0
	R/W	R	R	R	R	R/W	R/W	R/W	R/W
	Default	0	0	0	0	0	0	0	0

ASCHON: Auto Input Source Change Mode ON

0: Auto Input Source Change Mode OFF (default)

1: Auto Input Source Change Mode ON

TDMICH2, TDMICH1, TDMICH0 : TDM Input Mode Channel Select

• 256fs Mode

000: Ch1 (Lch), Ch2 (Rch) (default)

001: Ch3 (Lch), Ch4 (Rch)

010: Ch5 (Lch), Ch6 (Rch)

011: Ch7 (Lch), Ch8 (Rch)

100: Ch1 (Lch), Ch2 (Rch)

101: Ch3 (Lch), Ch4 (Rch)

110: Ch5 (Lch), Ch6 (Rch)

111: Ch7 (Lch), Ch8 (Rch)

• 512fs Mode

000: Ch1 (Lch), Ch2 (Rch) (default)

001: Ch3 (Lch), Ch4 (Rch)

010: Ch5 (Lch), Ch6 (Rch)

011: Ch7 (Lch), Ch8 (Rch)

100: Ch9 (Lch), Ch10 (Rch)

101: Ch11 (Lch), Ch12 (Rch)

110: Ch13 (Lch), Ch14 (Rch)

111: Ch15 (Lch), Ch16 (Rch)

In Parallel Control Mode (PSN pin = "H"), Ch1 (Lch) and Ch2 (Rch) are selected.

## 15. Jitter Tolerance

Figure 55 shows the jitter tolerance to ILRCK. The jitter quantity is defined by the jitter frequency and the jitter amplitude shown in Figure 55. When the jitter amplitude is 0.02UI<sub>pp</sub> or less, the AK4136 operates normally regardless of the jitter frequency.

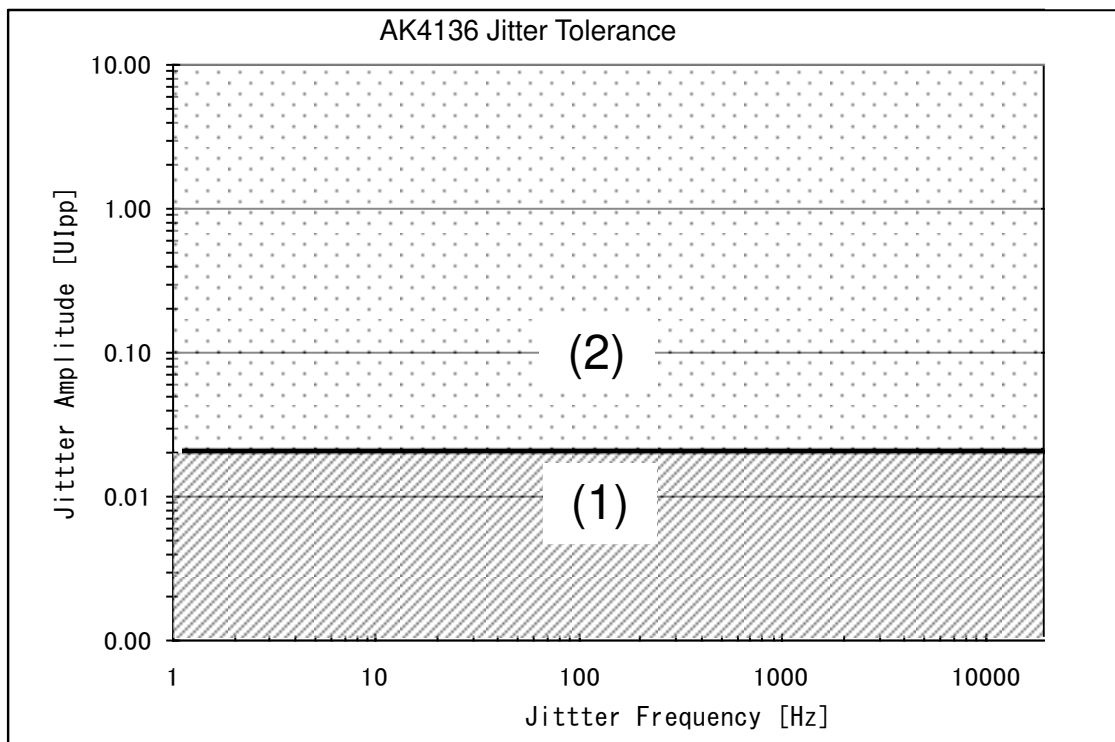

Figure 55. Jitter Tolerance

- (1) Normal Operation
- (2) There is a possibility that the output data is lost.

### Note

- Y axis is the jitter amplitude of ILRCK just before THD+N degradation starts.  
1UI (Unit Interval) is one cycle of ILRCK. When FSI = 48kHz, 1[UI<sub>pp</sub>]=1/48kHz  
=20.8μs
- This data is evaluated by adding jitter to ILRCK and IBICK, and comparing to the corresponding data input.

**16.Recommended External Circuit**

Figure 56 and Figure 57 shows the system connection diagram. An evaluation board (AKD4136) demonstrates application circuits, the optimum layout, power supply arrangements and measurement results.

- Serial Control mode (PSN pin = “L”)
- 4-wire serial Control Mode, Chip Address = “00”
- XT1/XTO = 256FSO, X’tal is used
- Input PORT: Slave mode, 64FSI IBICK  
Input audio interface format can be set by registers.
- Output PORT: Master mode, 32bit I2S Compatible, 64FSO OBICK.
- De-emphasis filter can be switched ON/OFF by the register setting.

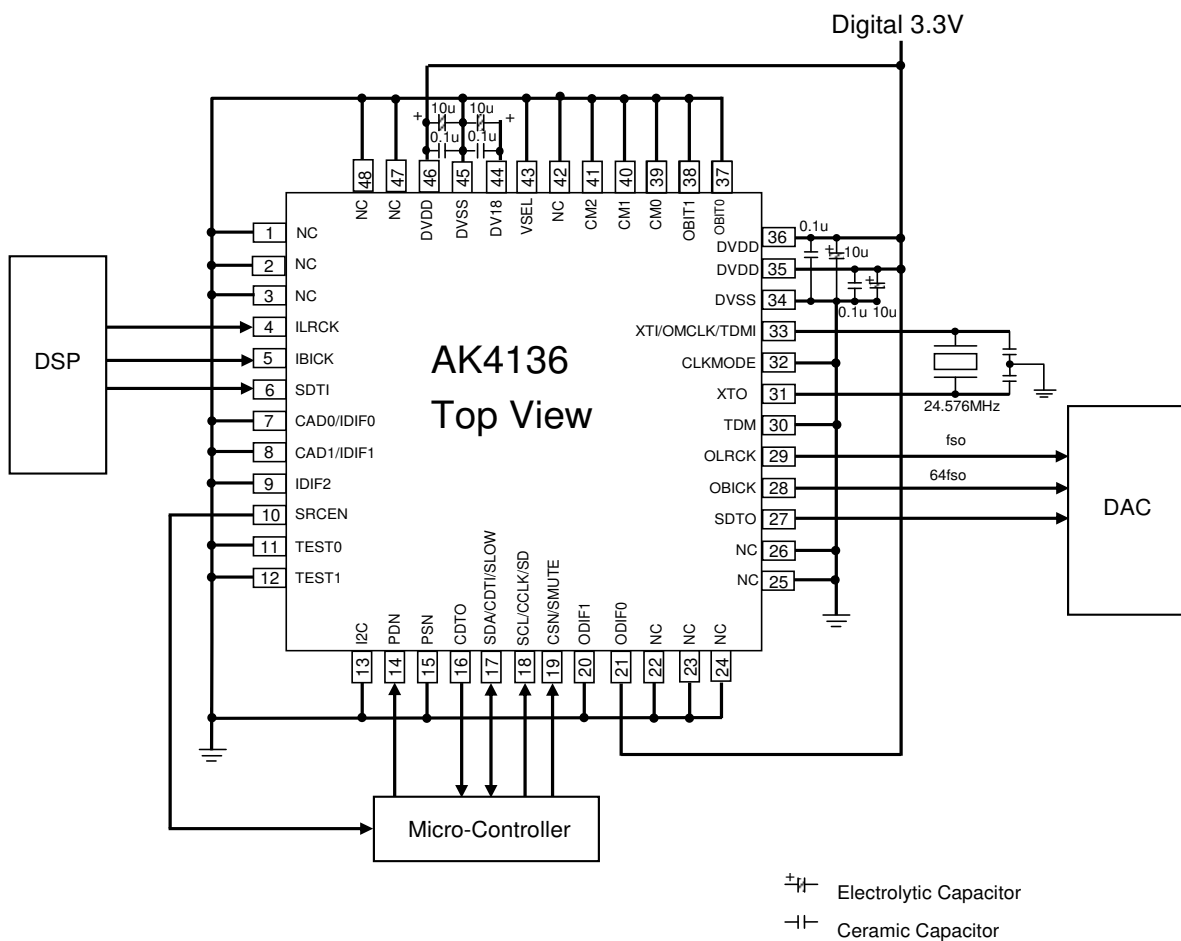

Notes:

- DVSS of the AK4136 must be distributed separately from the ground of external controllers.
- All digital input pins should not be allowed to float.
- Refer to Table 5 for the capacitor values near the X’tal.

Figure 56. Typical Connection Diagram (serial control mode)

- Parallel Control Mode (PSN pin = “H”).
- XT1/XTO = 256FSO, X’tal is used.
- Input PORT: Slave mode, 32 or 16 bit I2S Compatible, 64 FSI IBICK  
Input audio interface format can be set by registers.
- Output PORT: Master mode, 32 bit I2S Compatible, 64FSO OBICK.
- De-emphasis filter is fixed to OFF.

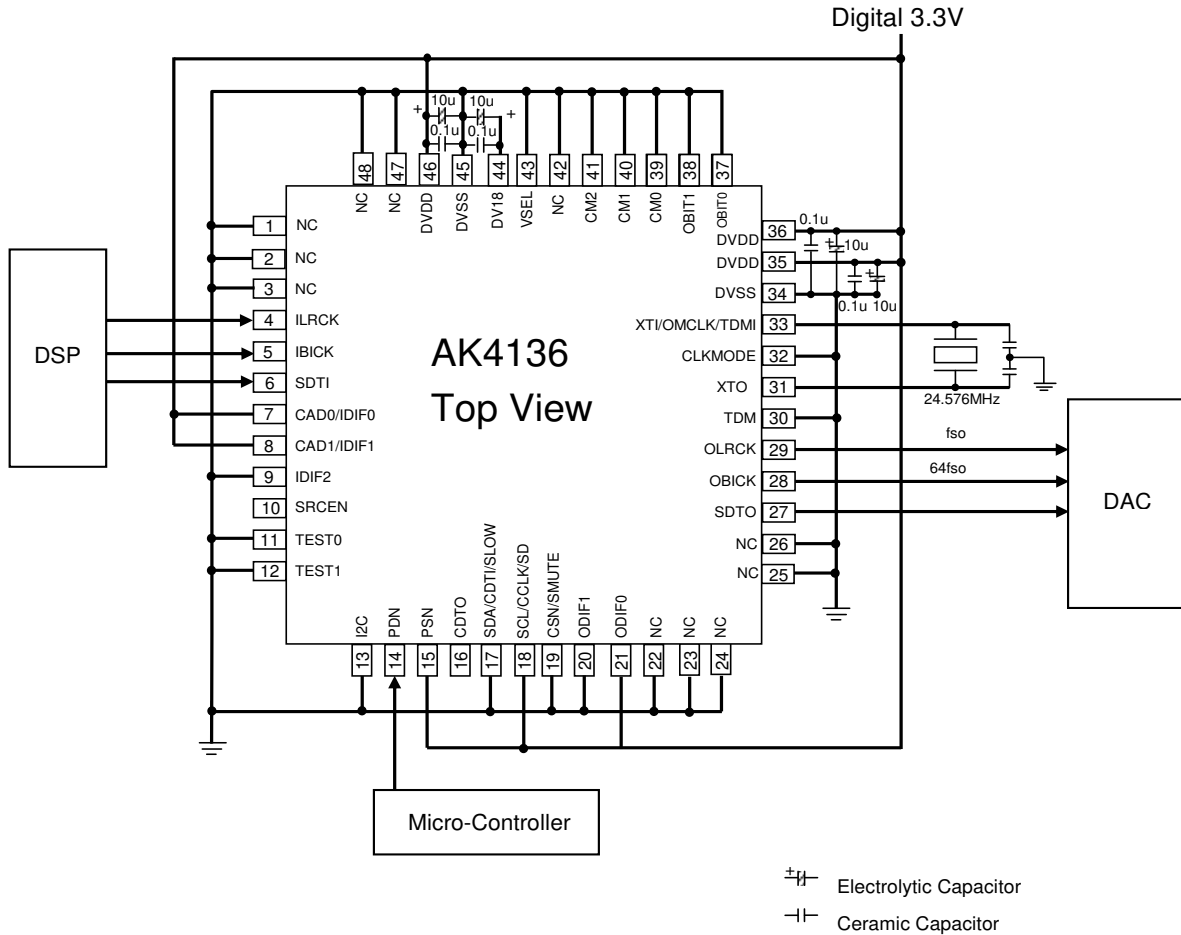

Notes:

- DVSS of the AK4136 must be distributed separately from the ground of external controllers.
- All digital input pins should not be allowed to float.
- Refer to Table 5 for the capacitor values near the X’tal.

Figure 57. Typical Connection Diagram (parallel control mode)

**17.Package**

■ Outline Dimensions

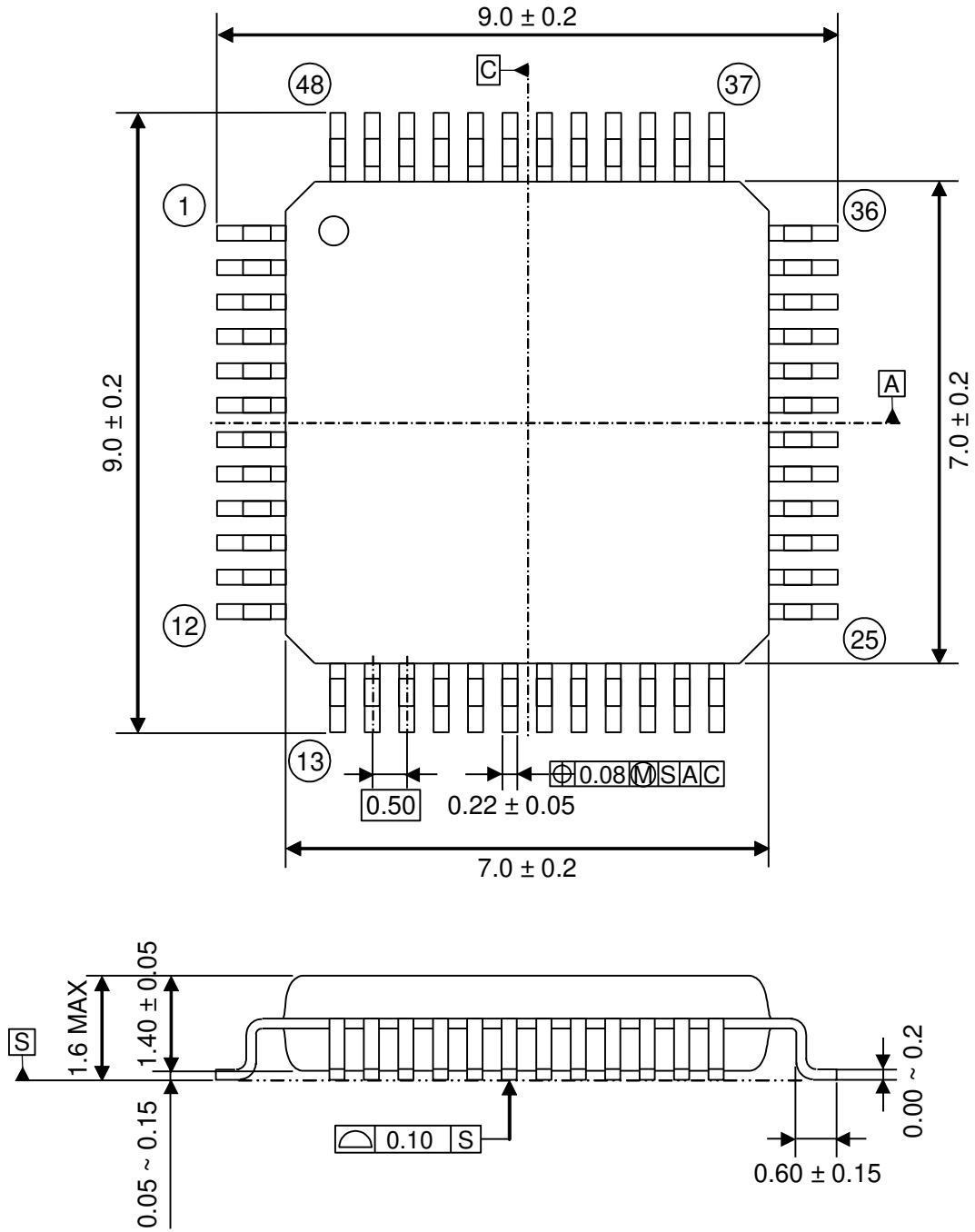

■ Material & Lead Finish

- Package molding compound: Epoxy
- Lead frame material: Cu
- Pin surface treatment: Solder (Pb free) plate

■ **Marking**

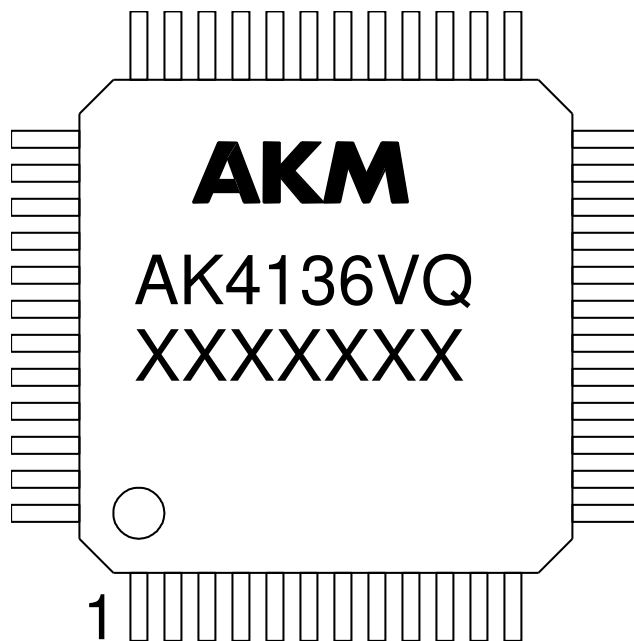

XXXXXXXX: Date code identifier

**18. Ordering Guide**

AK4136VQ  
AKD4136

-40 ~ +105°C      48-pin LQFP (0.5mm pitch)  
Evaluation Board for AK4136



<b>19. Revision History</b>
-----------------------------

Date (Y/M/D)	Revision	Reason	Page	Contents
16/01/21	00	First Edition		
22/04/22	01	Error Condition	5	Figure 2 Pin names are visible. #7, #17, #18
		Description Addition	9	Note 5 Below sentence is added. Regarding Digital Input pins, maximum value which is lower value (DVDD + 0.3) or 4.3 V.
		Decsription Changed	32	Table3 and Table4 are integrated one Table.
		Decsription Changed	32	Note 17 In serial control mode (PSN pin = "L"), the setting of IDIF2-0 bit is valid. In parallel control mode (PSN pin = "H"), the setting of IDIF2-0 pin is valid.
		Description Addition	32	Note 18 In case parallel control mode, L1 and R1 are selected data channels in TDM input mode. In case serial control mode, the data channels are selected by TDMICH2-0 bits setting in TDM input mode. Mode 4 and 5 (TDM256), R1 is available in below frequency range. ILRCK: 8kHz to 18kHz, 21.8295kHz to 36kHz, 43.4385kHz to 71.5kHz, 86.436kHz to 96kHz Mode 6 and 7 (TDM512), R1 is available in below frequency range. ILRCK: 8kHz to 9kHz Mode 6 and 7 (TDM512), in case TDMICH2-0bit = "001" (just Parallel Control mode), R2 is available in below frequency range. ILRCK: 8kHz to 18kHz, 21.8295kHz to 36kHz, 43.4385kHz to 48kHz  Regarding L1, R1 and R2, please refer <a href="#">Figure 22</a> , <a href="#">Figure 23</a> , <a href="#">Figure 24</a> and <a href="#">Figure 25</a> .
Decsription Changed	36, 37	Pin name of XTI/OMCLK in Master mode explanation, Table 4 and Figure 26, 27: XTI/OMCLK → XTI/OMCLK/TDMI		

**IMPORTANT NOTICE**

0. Asahi Kasei Microdevices Corporation (“AKM”) reserves the right to make changes to the information contained in this document without notice. When you consider any use or application of AKM product stipulated in this document (“Product”), please make inquiries the sales office of AKM or authorized distributors as to current status of the Products.
1. All information included in this document are provided only to illustrate the operation and application examples of AKM Products. AKM neither makes warranties or representations with respect to the accuracy or completeness of the information contained in this document nor grants any license to any intellectual property rights or any other rights of AKM or any third party with respect to the information in this document. You are fully responsible for use of such information contained in this document in your product design or applications. **AKM ASSUMES NO LIABILITY FOR ANY LOSSES INCURRED BY YOU OR THIRD PARTIES ARISING FROM THE USE OF SUCH INFORMATION IN YOUR PRODUCT DESIGN OR APPLICATIONS.**
2. The Product is neither intended nor warranted for use in equipment or systems that require extraordinarily high levels of quality and/or reliability and/or a malfunction or failure of which may cause loss of human life, bodily injury, serious property damage or serious public impact, including but not limited to, equipment used in nuclear facilities, equipment used in the aerospace industry, medical equipment, equipment used for automobiles, trains, ships and other transportation, traffic signaling equipment, equipment used to control combustions or explosions, safety devices, elevators and escalators, devices related to electric power, and equipment used in finance-related fields. Do not use Product for the above use unless specifically agreed by AKM in writing.
3. Though AKM works continually to improve the Product’s quality and reliability, you are responsible for complying with safety standards and for providing adequate designs and safeguards for your hardware, software and systems which minimize risk and avoid situations in which a malfunction or failure of the Product could cause loss of human life, bodily injury or damage to property, including data loss or corruption.
4. Do not use or otherwise make available the Product or related technology or any information contained in this document for any military purposes, including without limitation, for the design, development, use, stockpiling or manufacturing of nuclear, chemical, or biological weapons or missile technology products (mass destruction weapons). When exporting the Products or related technology or any information contained in this document, you should comply with the applicable export control laws and regulations and follow the procedures required by such laws and regulations. The Products and related technology may not be used for or incorporated into any products or systems whose manufacture, use, or sale is prohibited under any applicable domestic or foreign laws or regulations.
5. Please contact AKM sales representative for details as to environmental matters such as the RoHS compatibility of the Product. Please use the Product in compliance with all applicable laws and regulations that regulate the inclusion or use of controlled substances, including without limitation, the EU RoHS Directive. AKM assumes no liability for damages or losses occurring as a result of noncompliance with applicable laws and regulations.
6. Resale of the Product with provisions different from the statement and/or technical features set forth in this document shall immediately void any warranty granted by AKM for the Product and shall not create or extend in any manner whatsoever, any liability of AKM.
7. This document may not be reproduced or duplicated, in any form, in whole or in part, without prior written consent of AKM.