

Switching Power Supply S82J

DIN-Rail Mounting Industrial Power Supplies with Capacity Up to 600 W

- Models range from 10 to 600 W.
- UL 508 approval.
- Class 2 approval available for models below 100 W.
- Universal input or selectable input.
- Wide range of output voltages: 5 V, 12 V, 15 V, or 24 V.
- UL, CSA, VDE, and CE Approvals.
- 3-Year warranty.

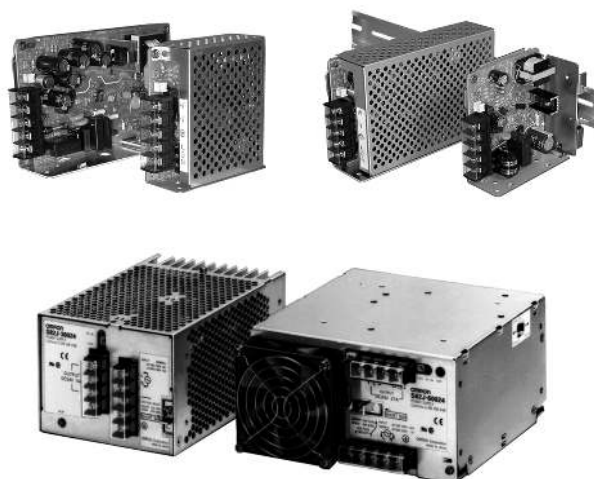

Ordering Information

■ OPEN-FRAME TYPE POWER SUPPLIES

Stock Note: Shaded models are normally stocked.

Rated input voltage	Power ratings	Output		Part number	
		Voltage	Current	Front-mounting bracket	DIN-rail mounting bracket
100 to 240 VAC	10 W	5 V	2 A	S82J-01005A	S82J-01005AD
		12 V	1 A	S82J-01012A	S82J-01012AD
		15 V	0.7 A	S82J-01015A	S82J-01015AD
		24 V	0.5 A	S82J-01024A	S82J-01024AD
	25 W	5 V	5 A	S82J-02505A	S82J-02505AD
		12 V	2.1 A	S82J-02512A	S82J-02512AD
		15 V	1.7 A	S82J-02515A	S82J-02515AD
		24 V	1.1 A	S82J-02524A	S82J-02524AD
	50 W	5 V	10 A	S82J-05005A	S82J-05005AD
		12 V	4.2 A	S82J-05012A	S82J-05012AD
		24 V	2.1 A	S82J-05024A	S82J-05024AD
	120 or 240 VAC (automatically selected)	100 W	5 V	20 A	S82J-10005A
100 to 240 VAC	12 V		8.5 A	S82J-10012A	S82J-10012AD
	15 V		7 A	S82J-10015A	S82J-10015AD
	24 V		4.5 A	S82J-10024A	S82J-10024AD
120 or 240 VAC (automatically selected)	150 W	24 V	6.5 A	S82J-15024A	S82J-15024AD

■ COVERED-FRAME TYPE POWER SUPPLIES

Stock Note: Shaded models are normally stocked.

Rated input voltage	Power ratings	Output		Part number	
		Voltage	Current	Front-mounting bracket	DIN-rail mounting bracket
100 to 240 VAC	10 W	5 V	2 A	S82J-01005D	S82J-01005DD
		12 V	1 A	S82J-01012D	S82J-01012DD
		15 V	0.7 A	S82J-01015D	S82J-01015DD
		24 V	0.5 A	S82J-01024D	S82J-01024DD
	25 W	5 V	5 A	S82J-02505D	S82J-02505DD
		12 V	2.1 A	S82J-02512D	S82J-02512DD
		15 V	1.7 A	S82J-02515D	S82J-02515DD
		24 V	1.1 A	S82J-02524D	S82J-02524DD
	50 W	5 V	10 A	S82J-05005D	S82J-05005DD
		12 V	4.2 A	S82J-05012D	S82J-05012DD
		24 V	2.1 A	S82J-05024D	S82J-05024DD
	120 or 240 VAC (automatically selected)	100 W	5 V	20 A	S82J-10005D
	12 V		8.5 A	S82J-10012D	S82J-10012DD
	15 V		7 A	S82J-10015D	S82J-10015DD
100 to 240 VAC	24 V		4.5 A	S82J-10024D	S82J-10024DD
120 or 240 VAC (automatically selected)	150 W	24 V	6.5 A	S82J-15024D	S82J-15024DD

■ ENCLOSED-FRAME TYPE POWER SUPPLIES

Stock Note: Shaded models are normally stocked.

Input voltage	Power rating	Output		Part number
		Voltage	Current	
120 or 230 VAC (selectable)	300 W	24 V	14.0 A	S82J-30024
	600 W	24 V	27.0 A	S82J-60024

- Note: 1. A mounting bracket is included with each power supply.
 2. To order without a mounting bracket (normally included with the 300 W or 600 W), add an "N" at the end of the part number.
 3. For other accessories, refer to the *Accessories* section that follows.

■ ACCESSORIES

Stock Note: Shaded models are normally stocked.

Description	Applicable power supplies	Part number
Front-mounting bracket	for 100-W, 24-V models	S82Y-J10F
DIN-rail	1 m (3.28 ft) length for 10- to 150-W models	PFP-100N/PFP-100N2
	0.5 m (1.64 ft) length for 10- to 150-W models	PFP-50N
Cover	for 10-W models	S82Y-J01K
	for 25-W models	S82Y-J02K
	for 50-W models	S82Y-J05K
	for 100-W, 24-V models	S82Y-J10K
Fan	for 600-W models	S82Y-JFAN
Ferrite ring core (a set of 3 pieces in package)	for 300-W and 600-W models	S82Y-JC-T
Noise filter	for 300-W models for 200 to 230 VAC input	S82Y-JF3-N
	for 600-W models for 200 to 230 VAC input	S82Y-JF6-N

■ MODEL NUMBER LEGEND

S82J -

1		2	3	4		

1. Power ratings

010: 10 W
 025: 25 W
 050: 50 W
 100: 100 W
 150: 150 W
 300: 300 W
 600: 600 W

2. Output voltage

05: 5 V
 12: 12 V
 15: 15 V
 24: 24 V

3. Configuration

A: Open-frame type, front terminals
 B: Covered-type, front terminals
 None: Enclosed-type, front terminals
 with mounting bracket

4. Mounting Bracket

None: Front-mounting Bracket Type
 D: DIN-rail Mounting Bracket Type

Specifications

Item		100 to 240 VAC input				120 or 240 VAC (selected automatically)		120 or 230 VAC (selectable)		
		10 W	25 W	50 W	100 W (24 V)	100 W (5, 12, 15 V)	150 W	300 W	600 W	
Efficiency (typical)		67% min. (77% min. for 50-W, 24-V models)			83% min.	75% min.	82% min.			
Input	Voltage	100 to 240 VAC (85 to 264 VAC) 110 to 170 VDC (set the terminal (L) to + side) (See Note 1.)			100 to 240 VAC (85 to 264 VAC)		120 (85 to 132) or 240 (170 to 264) VAC (selected automatically)		120 (85 to 132) or 230 (170 to 253) VAC (selectable)	
	Frequency	50/60 Hz (47 to 450 Hz)								
	Current (See Note 2.)	100 VAC input	0.35 A max.	0.8 A max.	1.4 A max.	2.5 A max.	2.5 A max.	3.5 A max.	8 A max.	14 A max.
		200 VAC input	0.3 A max.	0.6 A max.	0.8 A max.	1.15 A max.	1.4 A max.	2.1 A max.	4 A max.	7 A max.
	Leakage current (See Note 2.)	100 VAC input	0.5mA max.							
		200 VAC input	1mA max.							
	Inrush current (25°C, cold start) (See Note 2.)	100 VAC input	25 A max.							30 A max.
		200 VAC input	50 A max.							60 A max.
Noise filter	Yes									
Output (See Note 3.)	Voltage adjustment range	±10% (adjustable with variable resistor (V.ADJ))								
	Ripple (See Note 2.)	2% (p-p) max.								
	Input variation influence	0.4% max								
	Load variation influence	0.8% max. (with rated input, 10% to 100% load)								
	Temperature variation influence	0.05%/°C max. (with rated input and output)								
	Startup time	500 ms max. (up to 90% of output voltage at rated input and output)						300 ms max. (up to 90% of output voltage at rated input and output)		
	Hold time (See Note 2.)	20 ms min.								
Additional function	Overload protection	105% to 160% of rated load current, inverted L drop/intermittent operation type, automatic reset				105% min. of rated load current, inverted L drop type, automatic reset (For the 600-W model, the circuit will be shut OFF when the overload exceeds 5s. Protection-ON alarm indicator lit (See Note 5.)				
	Overvoltage protection	NO			Yes (See Note 4.)	Yes (5-V output models only) (See Note 4.)	No		Yes, protection-ON alarm indicator lit (See Note 5.)	
	Overheat protection	No							Yes, protection ON alarm indicator lit (See Note 5.)	

(This table continues on the next page.)

Engineering Data

DERATING CURVE

S82J 10/25/50/100/150 W

- Note: 1. The derating curve shown is for standard installation. The derating curve depends on the mounting direction of the Power Supply.
2. Provide a minimum clearance of 20 mm between the Power Supplies. Refer to the *Mounting* information in the *Dimensions* section.

Open-frame type

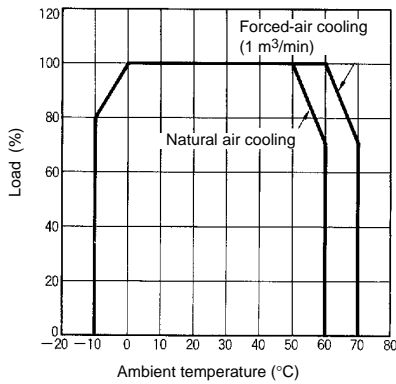

Covered-type

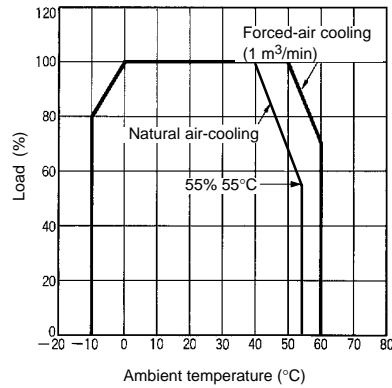

Mounting Position for Standard Installation

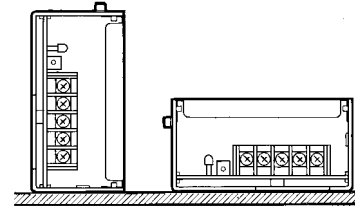

300-W Model Single Operation

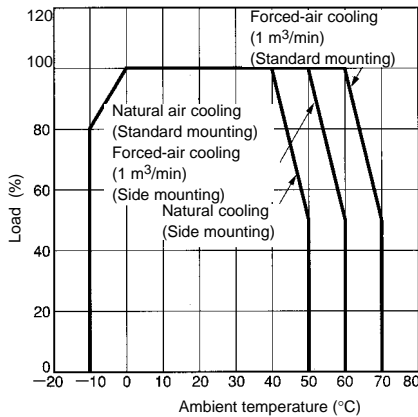

Parallel Operation

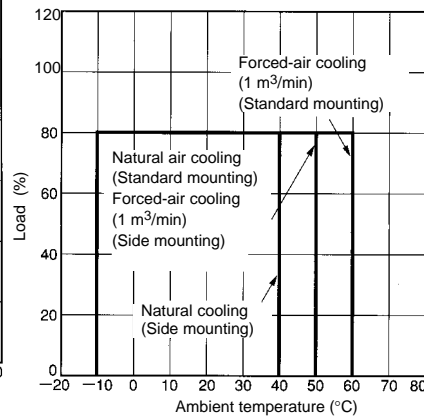

Mounting Position for Standard Installation

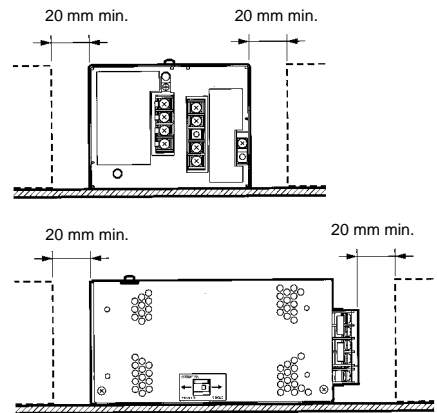

600-W Model

Single Operation

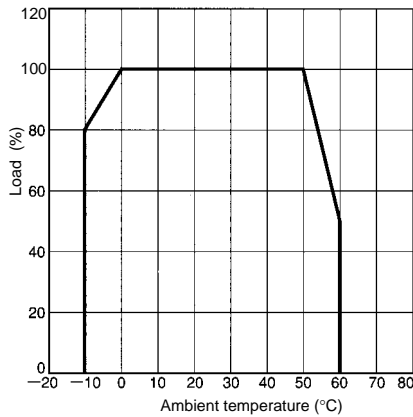

Parallel Operation

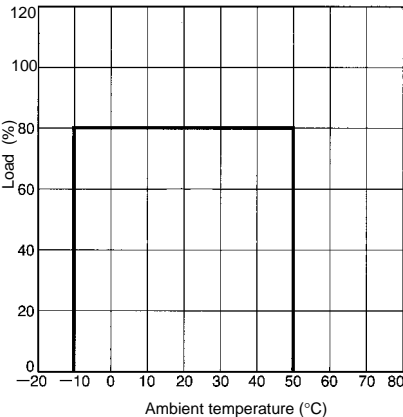

Mounting Position for Standard Installation

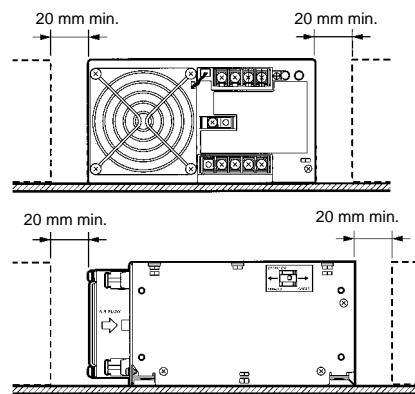

OVERLOAD PROTECTION

10- to 300-W Models

The Power Supply is provided with an overload protection function that protects the load and the power supply from possible damage by overcurrent. When the output current rises above 105% to 160% of the rated output current, the protection function is triggered, decreasing the output voltage. When the output current falls within the rated range, the overload protection function is automatically cleared.

10-W to 100-W (24-V) Models

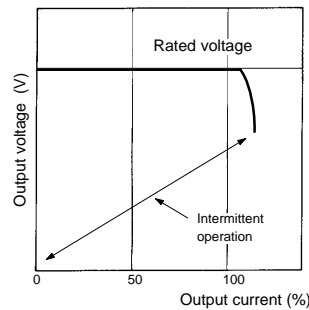

100-W (5, 12, 15-V), 150-W, 300-W models

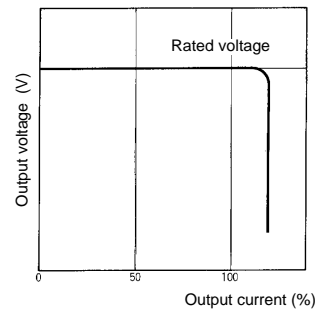

600-W Models

If an excessive current flows for 5 sec or more, the output will be turned off and simultaneously protection-ON alarm indicator will be lit. To reset the S82J, turn off the input voltage, leave the S82J for at least three minutes, and then apply the input voltage again.

Note: Do not continue using the S82J with the output terminals short-circuited or the overcurrent condition continued, otherwise the internal elements of the S82J may be damaged or broken.

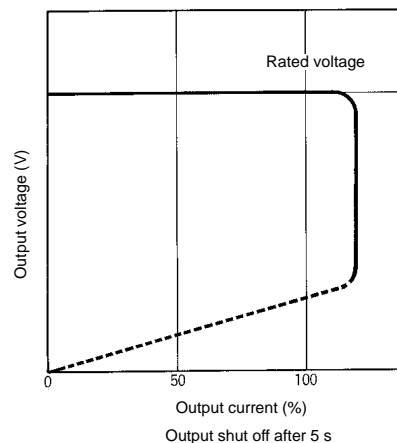

OVERVOLTAGE PROTECTION

100-W (5, 24 V) Output Models

These power supplies have an overvoltage protection function that protects the load and the power supply from possible damage by overvoltage. When the output voltage rises above a set value (120% of the rated output voltage), the protection function is triggered, shutting off the output voltage. If this occurs, reset the power supply by turning it off for 1 minute minimum and then turning it on again.

300- and 600-W Models

If a voltage that is 120% of the rated output voltage or above is output, the output voltage will be turned off and simultaneously protection-ON alarm indicator will be lit. To reset the S82J, turn off the input voltage, leave the S82J for at least three minutes if it is a 600-W model or at least 90 seconds if it is a 300-W model, and then apply the input voltage again.

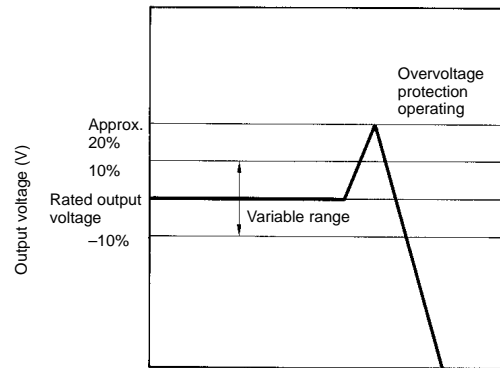

Note: The output voltage can be varied by the V. ADJ adjuster on the front panel. When it is set to a value 10% higher than the rated value, the overvoltage protection function may be effected.

OVERHEAT PROTECTION FUNCTION

600-W Model Only

If the internal temperature of the S82J rises excessively as a result of fan failure or any other reason, the overheat protection circuit will be triggered to protect the internal elements of the S82J and simultaneously a protection-ON alarm indicator will be lit. To reset the S82J, turn off the input voltage, leave the S82J for at least three minutes, and then apply the input voltage again.

INRUSH CURRENT, START UP TIME, HOLD TIME

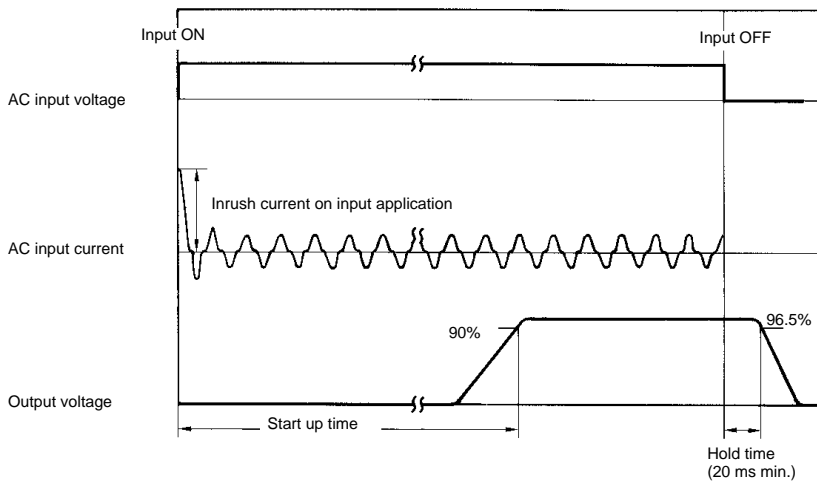

Installation

■ S82J 10 W TO 150 W

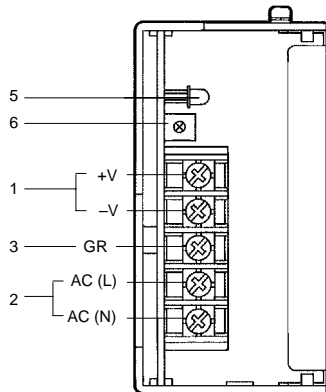

300-W Models

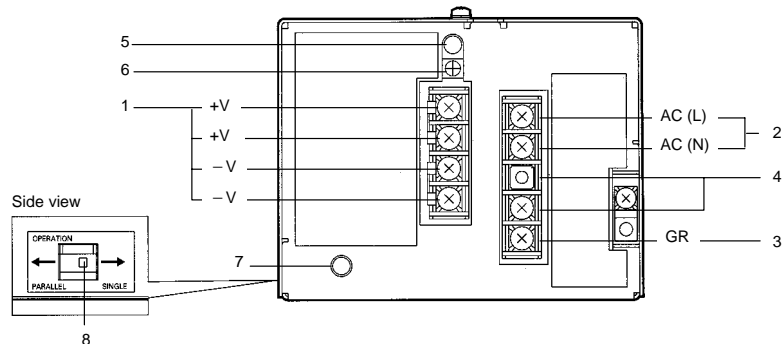

600-W Models

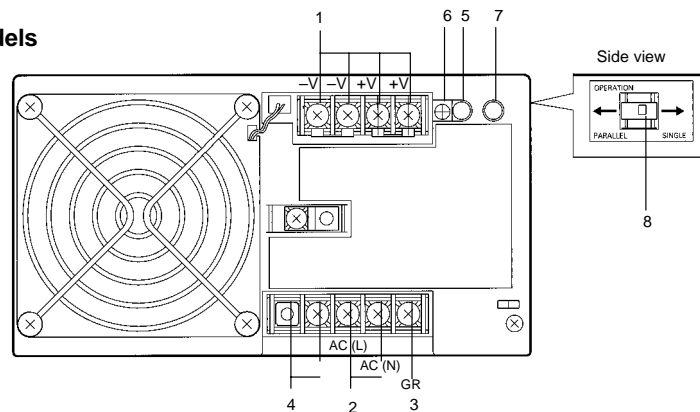

1. **DC Output Terminals:** Connect the load lines to these terminals.
2. **Input Terminals:** Connect the input lines to these terminals.
3. **Ground Terminal (GR):** Connect a ground line to this terminal.
4. **Input Voltage Selector Terminals:** Short-circuit the terminals if the input is 100 to 120 VAC and open the terminals if the input is 200 to 230 VAC
 - Only for 300-W and 600-W unit.
5. **Output Indicator (DC ON):** Lights while a Direct Current (DC) output is ON.
6. **Output Voltage Adjuster (V.ADJ):** It is possible to increase or decrease the output voltage by 10%.
7. **Protection-ON Alarm Indicator:** The red indicator will be lit if the overvoltage (for a 300-/600-W model) or overheat protection (for a 600-W model) circuit is triggered. This indicator will also be lit when overcurrent (for a 600-W model) is detected.
8. **Parallel/Single Operation Selector:** Set the selector to PARALLEL if the Units are in parallel operation.

Operation

■ BLOCK DIAGRAMS

S82J-010□□□□ (10 W)

S82J-025□□□□ (25 W)

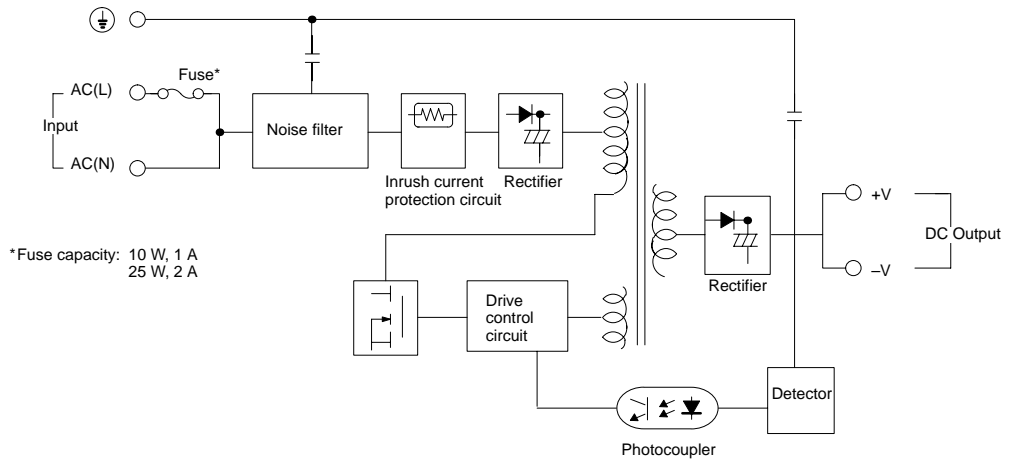

S82J-050□□□□ (50 W)

S82J-10024□□ (100 W)

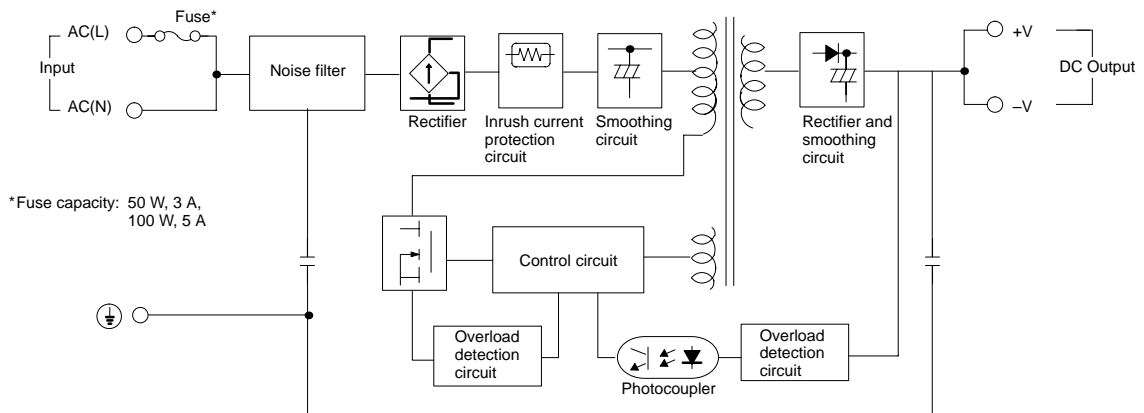

S82J-10005□□ (100 W)
 S82J-10012□□ (100 W)
 S82J-10015□□ (100 W)
 S82J-15024□□ (150 W)

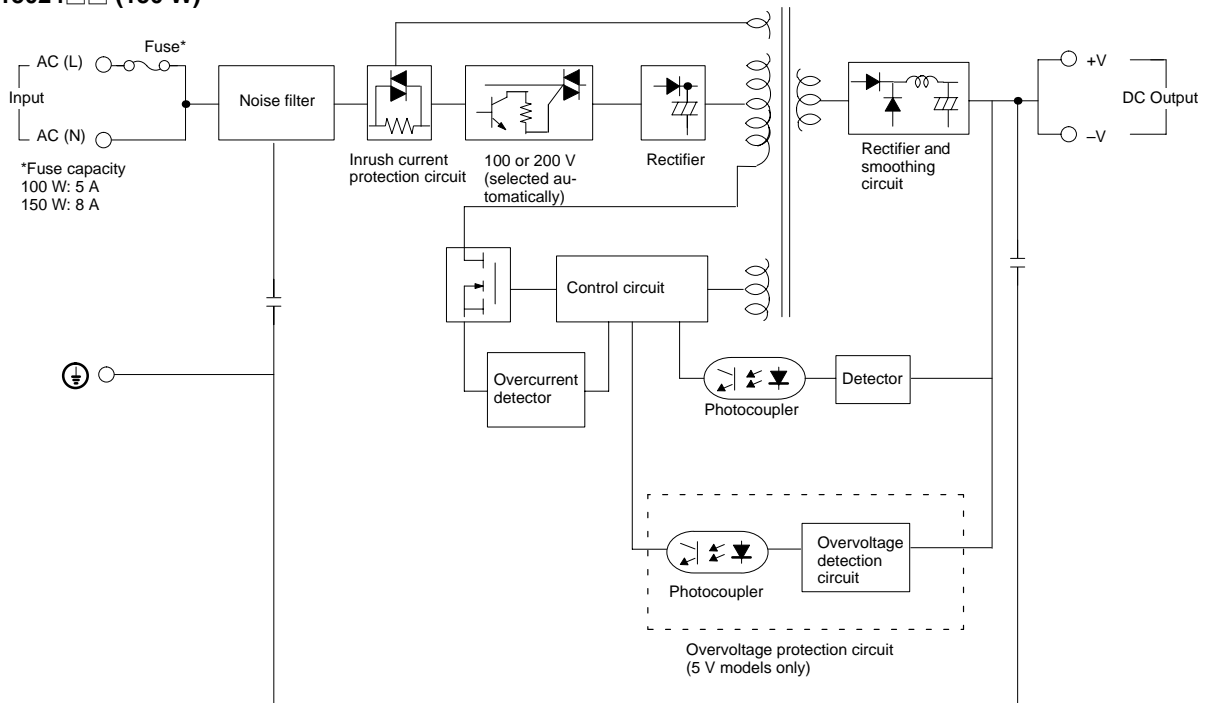

S82J-30024 (300 W)

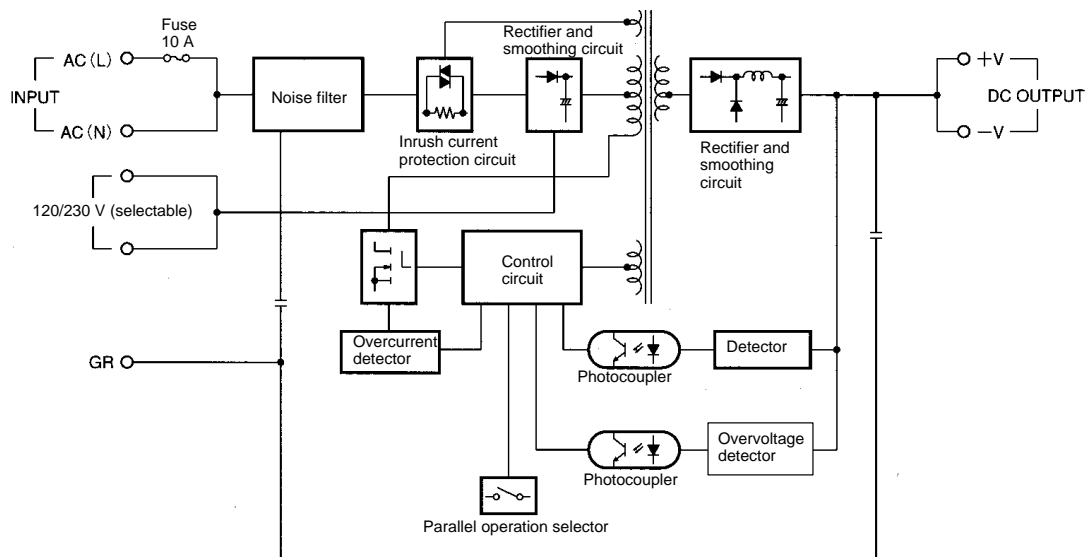

Note: Short-circuit the input voltage selector terminals if the input is 100 to 120 VAC. Keep the terminals open if the input is 200 to 230 VAC.

S82J-60024 (600 W)

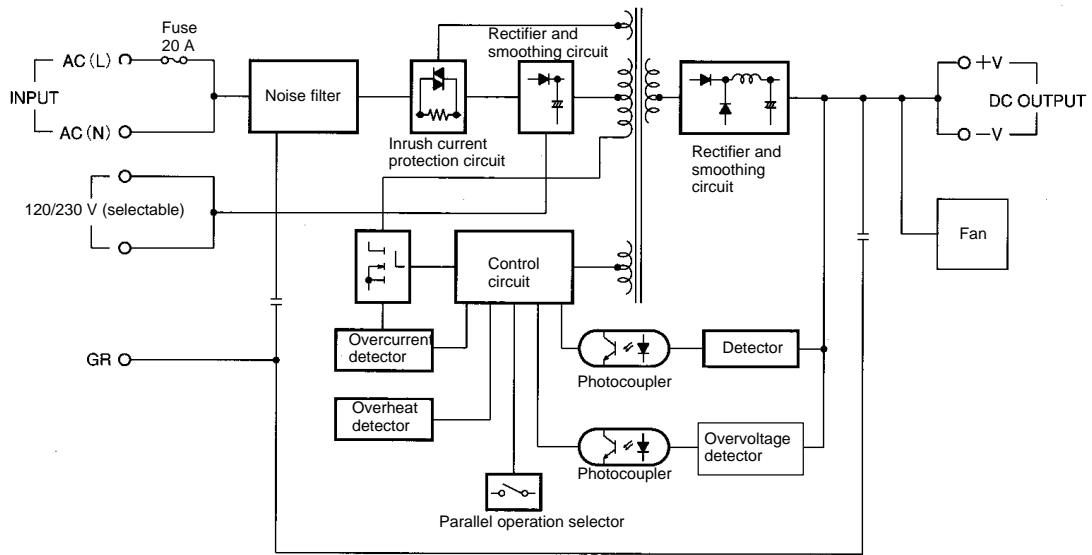

Note: Short-circuit the input voltage selector terminals if the input is 100 to 120 VAC. Keep the terminals open if the input is 200 to 230 VAC.

■ GENERATING OUTPUT VOLTAGE (\pm)

An output of \pm can be generated by using two power supplies as shown below, because the power supply produces a floating output.

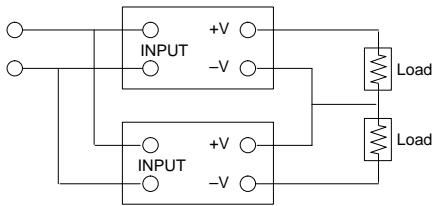

If operation amplifiers as loads are connected in series, connect a diode between the positive and negative output terminals of each Switching Power Supplies as shown in the illustration below. Without these diodes, the Power Supplies may not start when power is turned on, possibly damaging internal circuits over a period of time.

Use Schottky barrier diodes with a low forward voltage (V_F). Other types of diodes will not be effective.

Guidelines for the dielectric strength and current of the diodes are as follows:
 Dielectric strength: At least twice the rated output voltage of the Power Supply
 Forward current: At least twice the rated output current

No diodes are required for models that allow series operation.

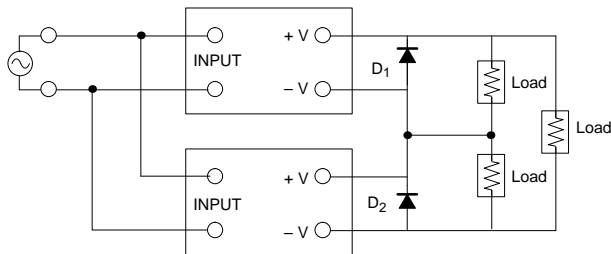

■ SERIES OPERATION

Only models with power ratings of 50/100/150/300/600 W allow series operation. As shown in the following diagram, the output voltage from each Switching Power Supply can be added.

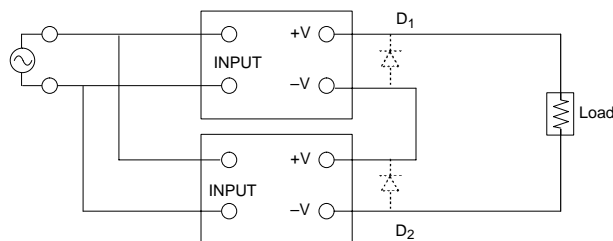

With the S82J-050□□□□ or S82J-10024□□, if the load is shorted a reverse voltage may result in the Power Supply causing deterioration and damage. It is recommended that diodes are connected as shown in the previous diagram (D_1 , D_2).

■ PARALLEL OPERATION

Only 300- and 600-W models can be in parallel operation. Do not operate any other models in parallel. The output of the models in parallel operation is a maximum of 80% of the rated output.

Set the parallel operation selector to PARALLEL if the Units are in parallel operation and make sure that the thickness and the length of all wires connected to the load are the same to ensure that the wires will have no voltage drop differences.

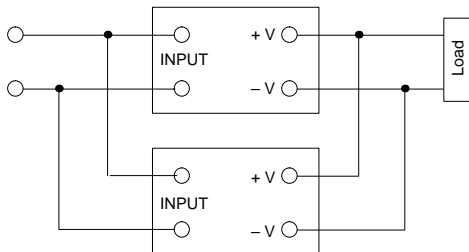

Dimensions

Unit: mm (inch)

FRONT-MOUNTING BRACKET TYPES

S82J-010□□□□ (10 W)

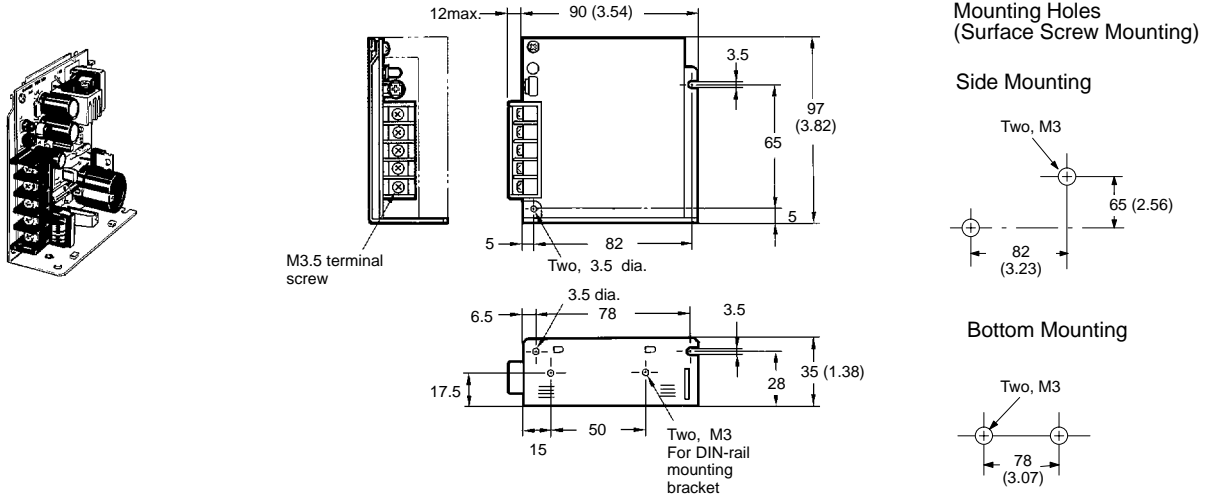

S82J-025□□□□ (25 W)

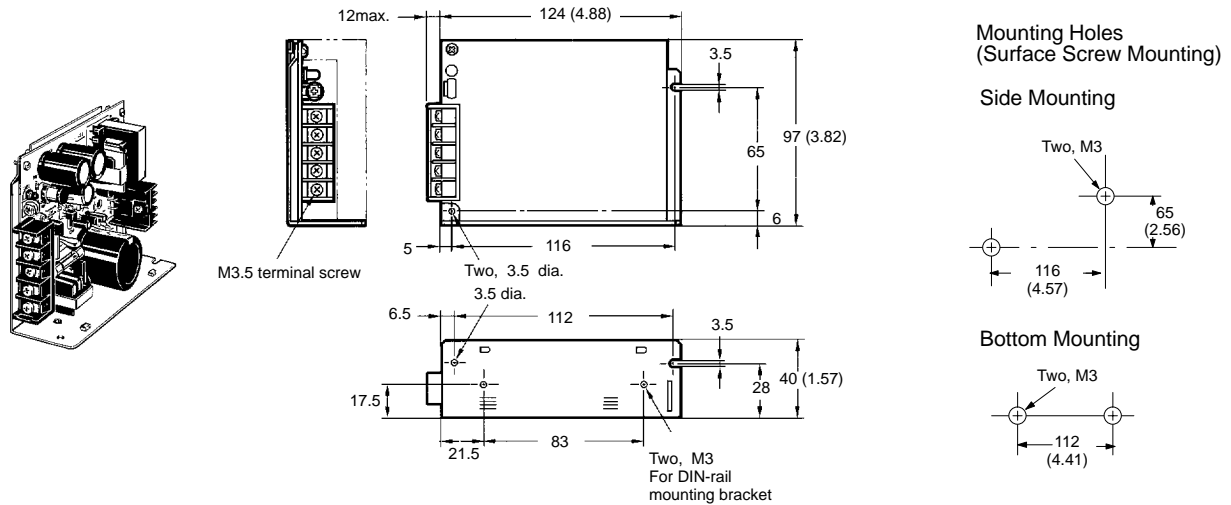

Unit: mm (inch)

S82J-050 □□□□ (50 W)

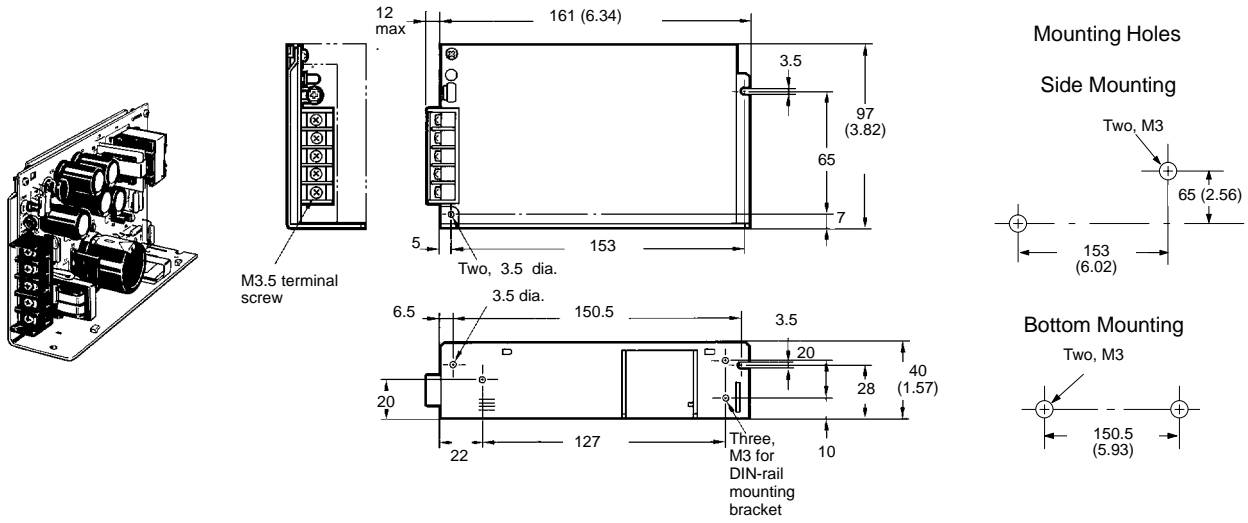

S82J-10024 □□ (100 W)

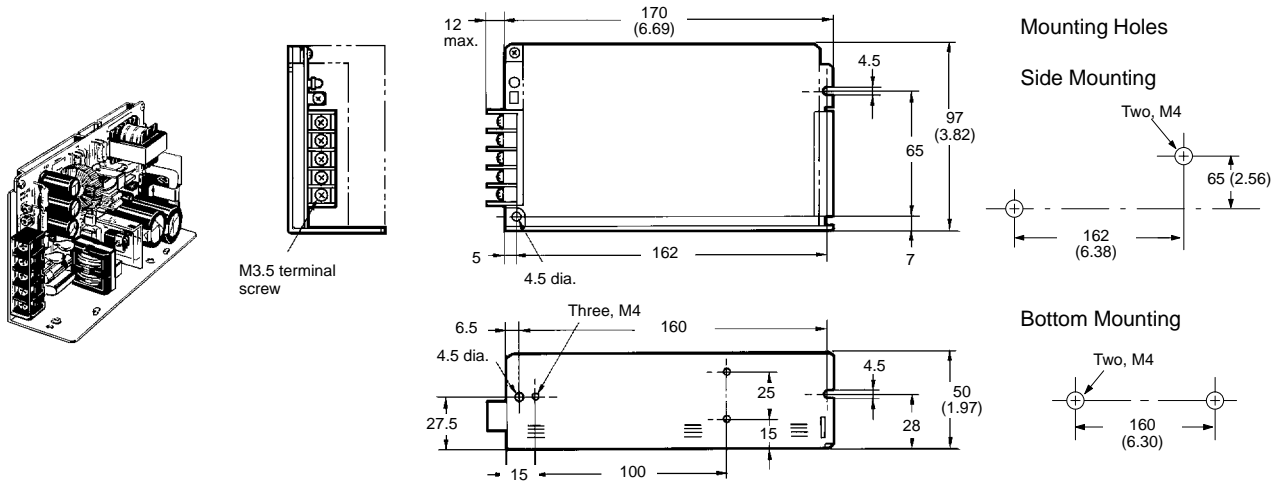

- S82J-10005 □ □ (100 W)
- S82J-10012 □ □ (100 W)
- S82J-10015 □ □ (100 W)
- S82J-15024 □ □ (150 W)

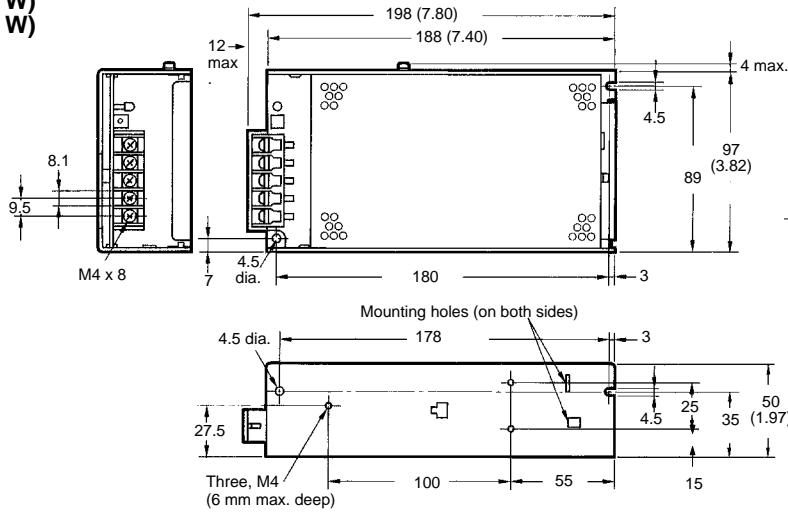
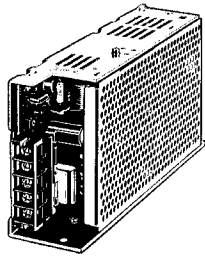

Mounting Holes

Side Mounting

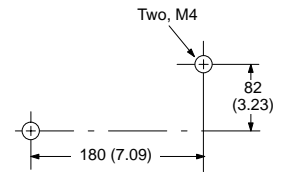

Bottom Mounting

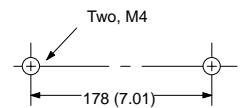

S82J-30024 (300 W)

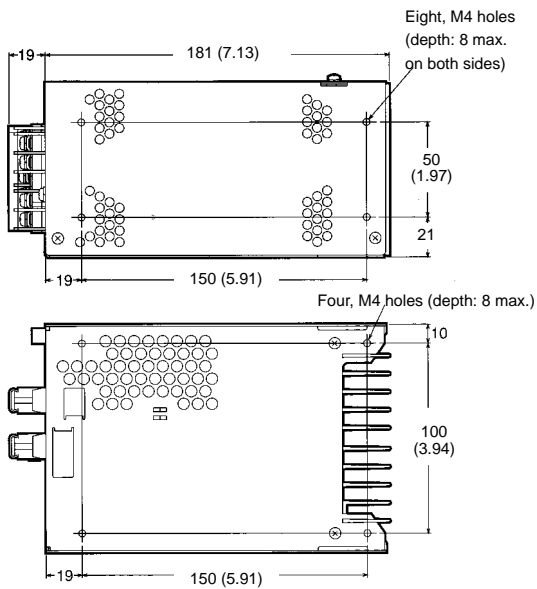
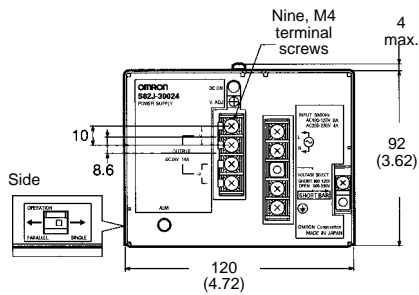
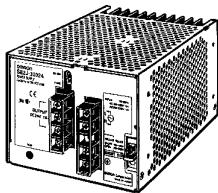

Mounting Holes

Side Mounting

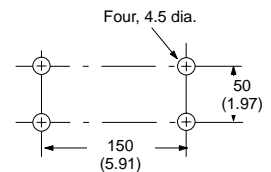

Bottom Mounting

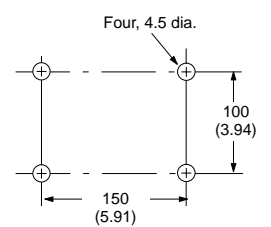

Unit: mm (inch)

S82J-60024 (600 W)

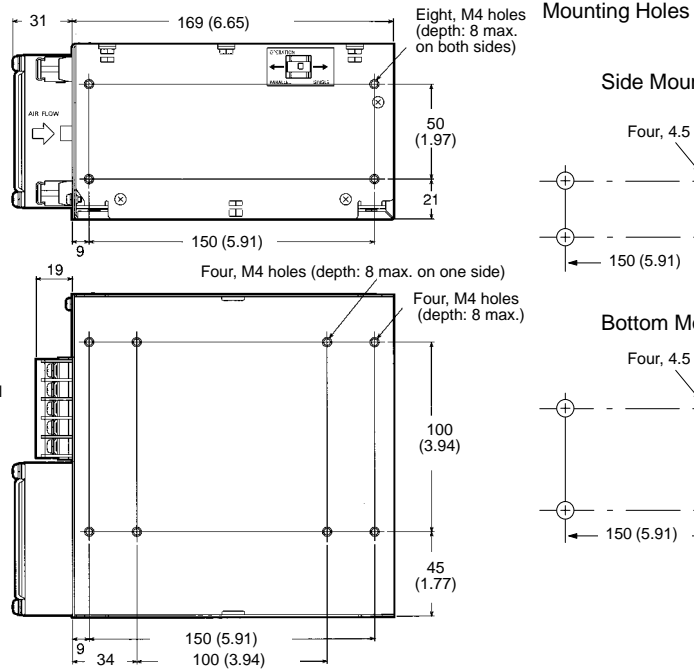
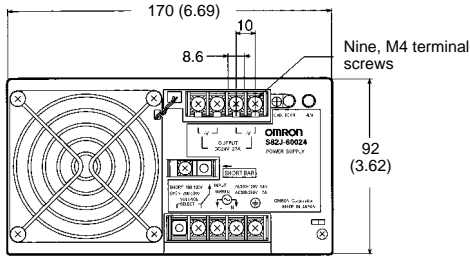
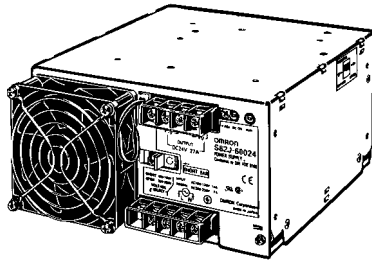

■ **MOUNTING BRACKET (INCLUDED WITH POWER SUPPLY UNIT)**

S82J 10-/25-/50-/100-W (24-V) Models

Front-mounting Bracket (Included)

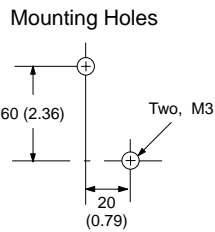
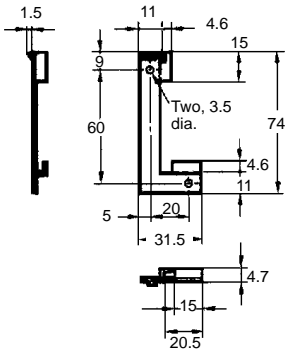

Using the Mounting Bracket

Attach the mounting bracket to the panel and loosely tighten the two screws. Insert the projected parts of the bracket (b) to the square holes of the power supply (a). Then securely tighten the screws.

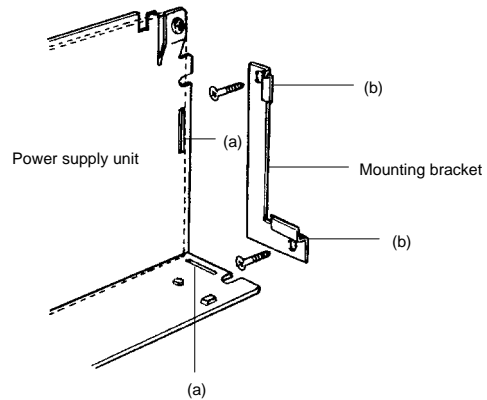

**S82J 100-W (5-/12-/15-V) Models or 150-W Models
Front Mounting Brackets (Included)**

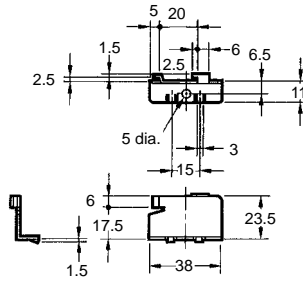
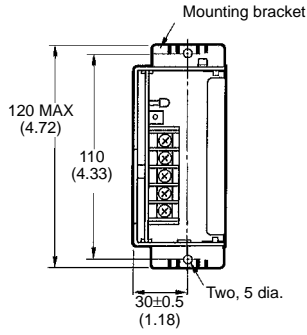

Mounting with Brackets

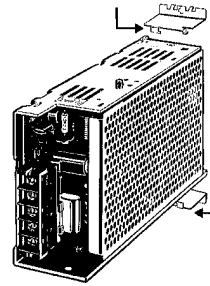

300-W Models

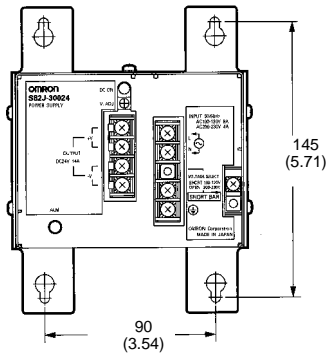

Appearance and Mounting Dimensions

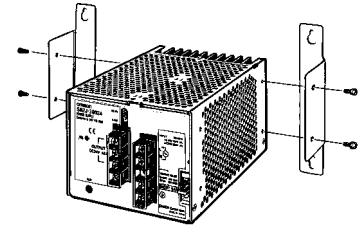
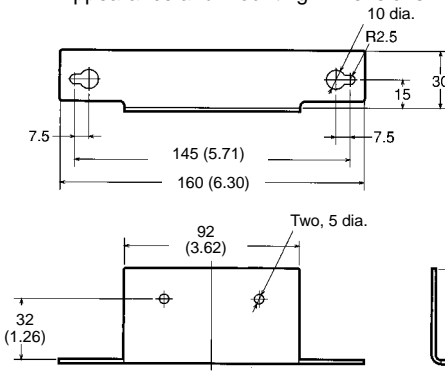

Note: Using the bracket provides 21.6 mm ventilation space.

600-W Models

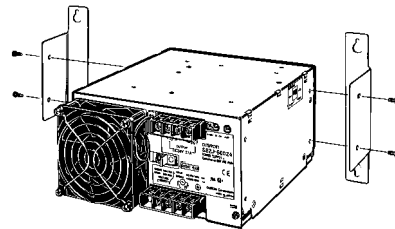
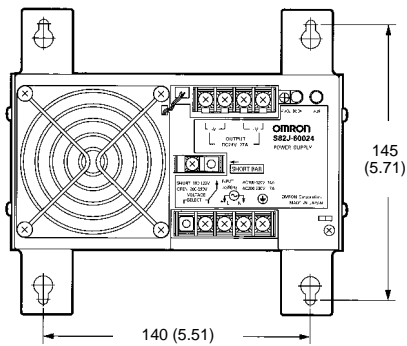

Note: Using the bracket provides 23.6 mm ventilation space.

■ DIN-RAIL MOUNTING BRACKET TYPES

S82J-010□□□□D (10 W)

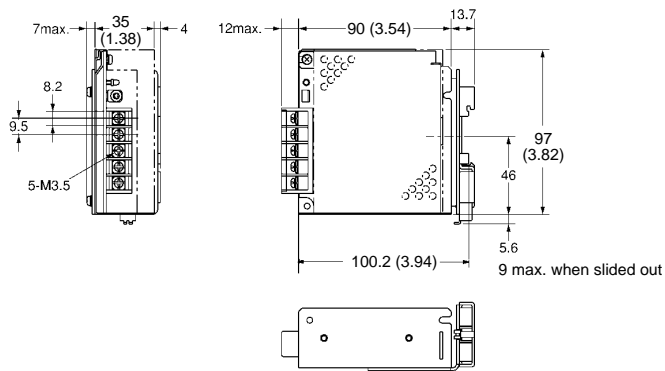
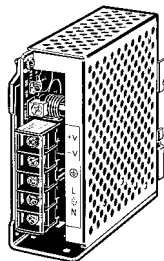

S82J-025□□□□D (25 W)

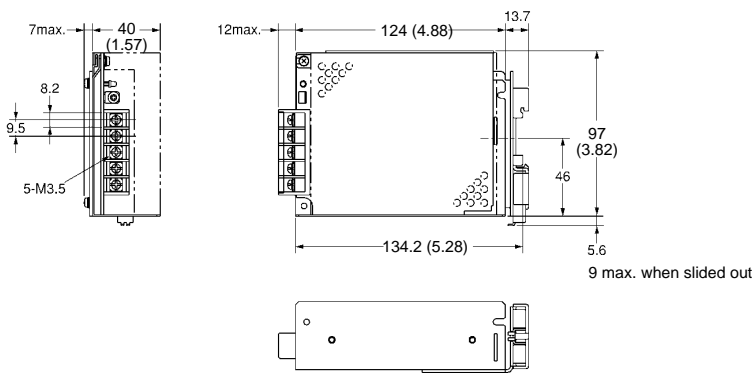
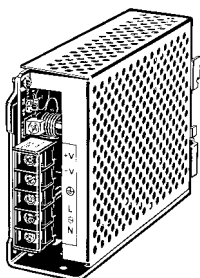

S82J-050□□□□D (50 W)

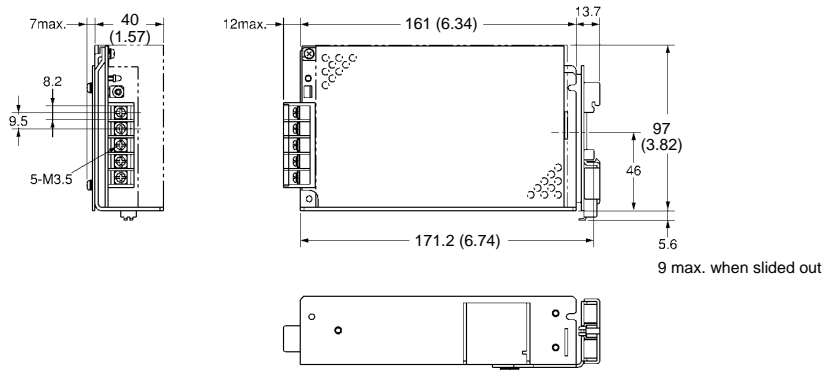
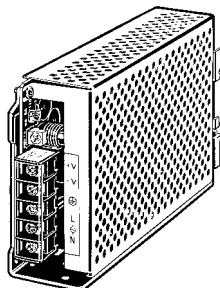

S82J-10024□□D (100 W, 24-V Output)

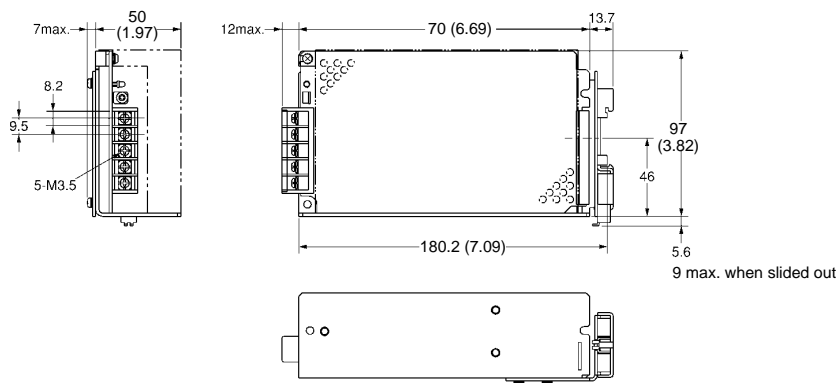
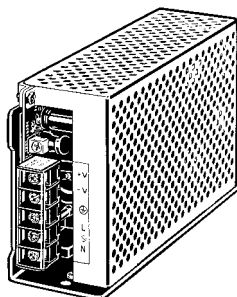

S82J-10005□D (100 W)
 S82J-10012□D (100 W)
 S82J-10015□D (100 W)
 S82J-15024□D (150 W)

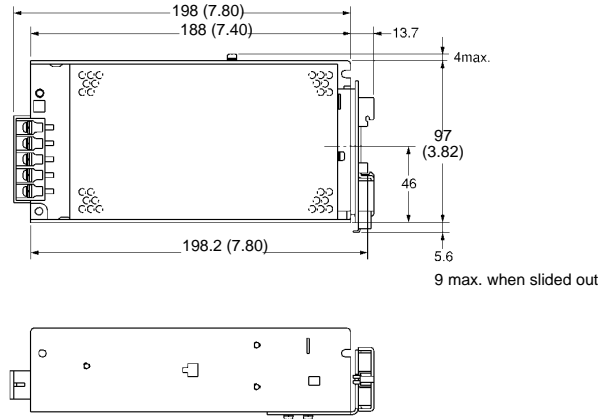
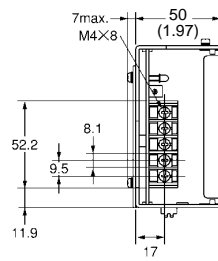
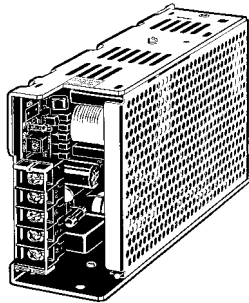

Accessories (Order Separately)

■ DIN RAIL (ORDER SEPARATELY)

PFP-100N/PFP-50N

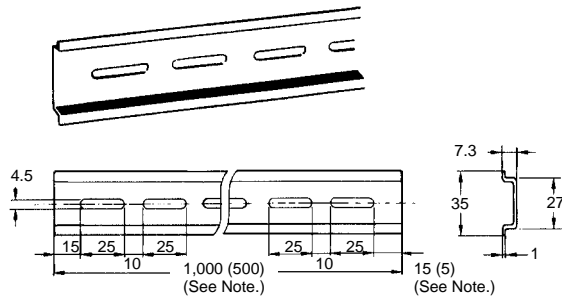

PFP-100N2

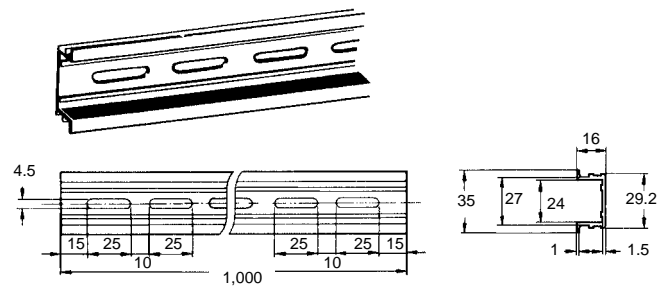

Note: The values shown in parentheses are for the PFP-50N.

■ FRONT-MOUNTING BRACKET FOR S82J-10024A AND S82J-10024D (ORDER SEPARATELY)

S82Y-J10F

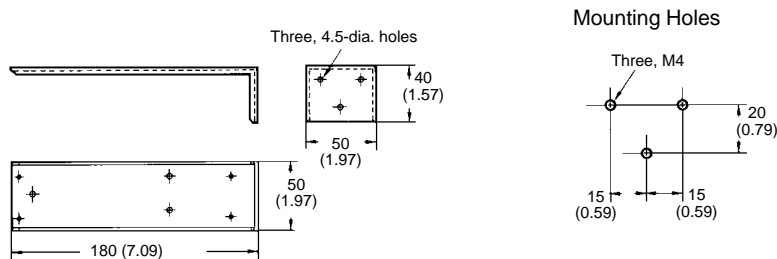

Note: The front mounting bracket (above) cannot be used for S82J 100-W (5, 12, 15 V) or 150-W models.

■ COVER (ORDER SEPARATELY)

Note: This optional cover is available for the open-frame models also.

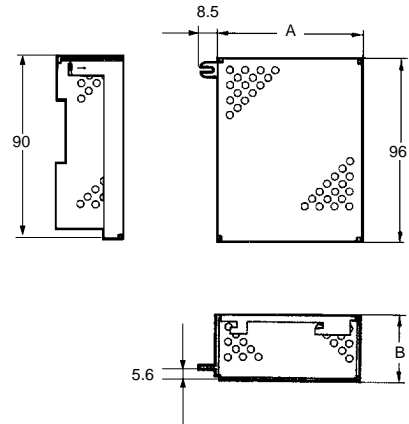
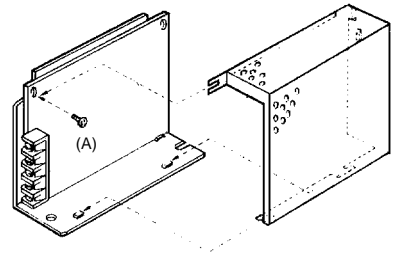
Item	S82Y-J01K	S82Y-J02K	S82Y-J05K	S82Y-J10K
Applicable supply unit	S82J-010□□□□	S82J-025□□□□	S82J-050□□□□	S82J-10024□□□
Dimensions	 <p>Attaching Cover to Power Supply</p> <p>Remove screw (A) before attaching the cover to the Power Supply. Tighten the screw to secure the cover on the Power Supply.</p> <p>Note: The derating curve shown in <i>Engineering Data</i> may change with changes in ambient temperature when the cover is attached to the Power Supply.</p> 			
Dimensions: A	75 mm (2.95)	109 mm (4.29)	146 mm (5.75)	154 mm (6.06)
B	35 mm (1.38)	39 mm (1.54)	38 mm (1.50)	48 mm (1.89)

■ FERRITE RING CORE (ORDER SEPARATELY)

S82Y-JC-T

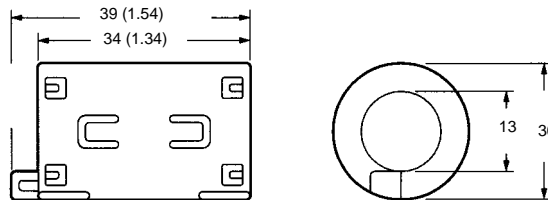
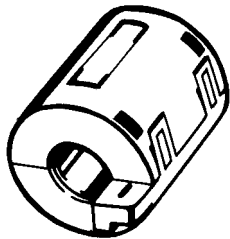

■ NOISE FILTER (ORDER SEPARATELY)

S82Y-JF3-N for 300-W Models for 200 to 230 VAC input
 S82Y-JF6-N for 600-W Models for 200 to 230 VAC input

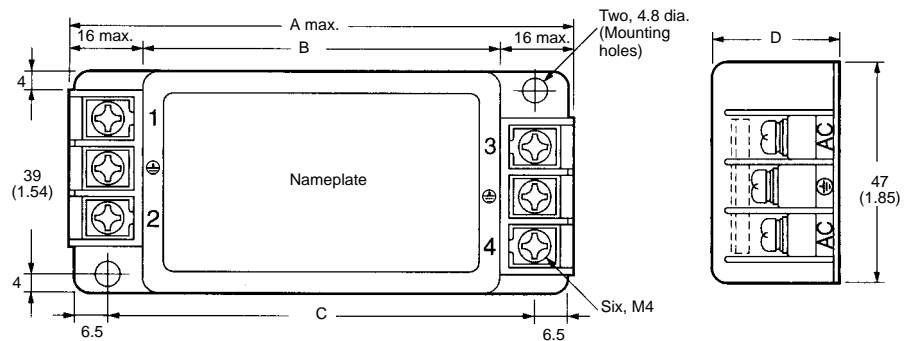
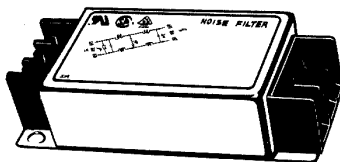

Model	A	B	C	D
S82Y-JF3-N	107 (4.21)	75 (2.95)	90 (3.54)	26 (1.02)
S82Y-JF6-N	117 (4.60)	85 (3.35)	100 (3.94)	30 (1.18)

■ MOUNTING METHODS

S82J 10/25/50/100 (24 V) W

The following three mounting methods are available.

- (A) Side mounting
- (B) Bottom mounting

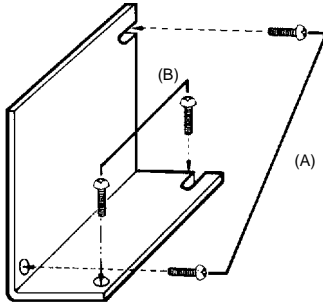

S82J 100 (5, 12, 15 V)/150 W

The following mounting methods are available.

- (A) Side mounting
- (B) Bottom mounting (secured with screws from the inside of the power supply)
- (C) Bottom mounting (secured with screws from the back of the power supply)

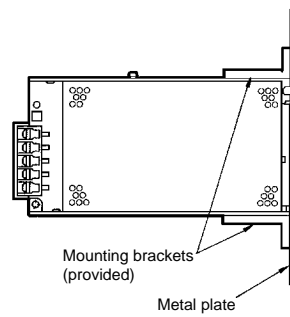
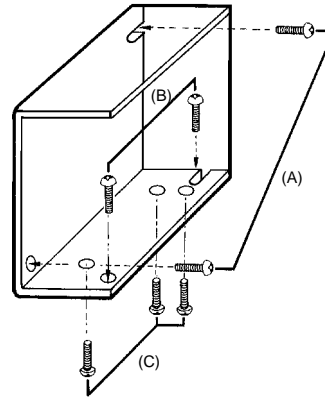

- (D) Front mounting
Front mounting is possible with the mounting brackets provided. Refer to the *Dimensions* Section.

Certain Terms and Conditions of Sale

1. **Offer: Acceptance.** These terms and conditions (these "Terms") are deemed part of all catalogs, manuals or other documents, whether electronic or in writing, relating to the sale of goods or services (collectively, the "Goods") by Omron Electronics LLC and its subsidiary companies ("Seller"). Seller hereby objects to any terms or conditions proposed in Buyer's purchase order or other documents which are inconsistent with, or in addition to, these Terms. Please contact your Omron representative to confirm any additional terms for sales from your Omron company.
2. **Prices.** All prices stated are current, subject to change without notice by Seller. Buyer agrees to pay the price in effect at time of shipment.
3. **Discounts.** Cash discounts, if any, will apply only on the net amount of invoices sent to Buyer after deducting transportation charges, taxes and duties, and will be allowed only if (i) the invoice is paid according to Seller's payment terms and (ii) Buyer has no past due amounts owing to Seller.
4. **Orders.** Seller will accept no order less than \$200 net billing.
5. **Governmental Approvals.** Buyer shall be responsible for, and shall bear all costs involved in, obtaining any government approvals required for the importation or sale of the Goods.
6. **Taxes.** All taxes, duties and other governmental charges (other than general real property and income taxes), including any interest or penalties thereon, imposed directly or indirectly on Seller or required to be collected directly or indirectly by Seller for the manufacture, production, sale, delivery, importation, consumption or use of the Goods sold hereunder (including customs duties and sales, excise, use, turnover and license taxes) shall be charged to and remitted by Buyer to Seller.
7. **Financial.** If the financial position of Buyer at any time becomes unsatisfactory to Seller, Seller reserves the right to stop shipments or require satisfactory security or payment in advance. If Buyer fails to make payment or otherwise comply with these Terms or any related agreement, Seller may (without liability and in addition to other remedies) cancel any unshipped portion of Goods sold hereunder and stop any Goods in transit until Buyer pays all amounts, including amounts payable hereunder, whether or not then due, which are owing to it by Buyer. Buyer shall in any event remain liable for all unpaid accounts.
8. **Cancellation: Etc.** Orders are not subject to rescheduling or cancellation unless Buyer indemnifies Seller fully against all costs or expenses arising in connection therewith.
9. **Force Majeure.** Seller shall not be liable for any delay or failure in delivery resulting from causes beyond its control, including earthquakes, fires, floods, strikes or other labor disputes, shortage of labor or materials, accidents to machinery, acts of sabotage, riots, delay in or lack of transportation or the requirements of any government authority.
10. **Shipping: Delivery.** Unless otherwise expressly agreed in writing by Seller:
 - a. Shipments shall be by a carrier selected by Seller;
 - b. Such carrier shall act as the agent of Buyer and delivery to such carrier shall constitute delivery to Buyer;
 - c. All sales and shipments of Goods shall be FOB shipping point (unless otherwise stated in writing by Seller), at which point title to and all risk of loss of the Goods shall pass from Seller to Buyer, provided that Seller shall retain a security interest in the Goods until the full purchase price is paid by Buyer;
 - d. Delivery and shipping dates are estimates only.
 - e. Seller will package Goods as it deems proper for protection against normal handling and extra charges apply to special conditions.
11. **Claims.** Any claim by Buyer against Seller for shortage or damage to the Goods occurring before delivery to the carrier must be presented in writing to Seller within 30 days of receipt of shipment and include the original transportation bill signed by the carrier noting that the carrier received the Goods from Seller in the condition claimed.
12. **Warranties.** (a) **Exclusive Warranty.** Seller's exclusive warranty is that the Goods will be free from defects in materials and workmanship for a period of twelve months from the date of sale by Seller (or such other period expressed in writing by Seller). Seller disclaims all other warranties, express or implied. (b) **Limitations.** SELLER MAKES NO WARRANTY OR REPRESENTATION, EXPRESS OR IMPLIED, ABOUT NON-INFRINGEMENT, MERCHANTABILITY OR FITNESS FOR A PARTICULAR PURPOSE OF THE GOODS. BUYER ACKNOWLEDGES THAT IT ALONE HAS DETERMINED THAT THE GOODS WILL SUITABLY MEET THE REQUIREMENTS OF THEIR INTENDED USE. Seller further disclaims all warranties and responsibility of any type for claims or expenses based on infringement by the Goods or otherwise of any intellectual property right. (c) **Buyer Remedy.** Seller's sole obligation hereunder shall be to replace (in the form originally shipped with Buyer responsible for labor charges for removal or replacement thereof) the non-complying Good or, at Seller's election, to repay or credit Buyer an amount equal to the purchase price of the Good; provided that in no event shall Seller be responsible for warranty, repair, indemnity or any other claims or expenses regarding the Goods unless Seller's analysis confirms that the Goods were properly handled, stored, installed and maintained and not subject to contamination, abuse, misuse or inappropriate modification. Return of any goods by Buyer must be approved in writing by Seller before shipment. Seller shall not be liable for the suitability or unsuitability or the results from the use of Goods in combination with any electrical or electronic components, circuits, system assemblies or any other materials or substances or environments. Any advice, recommendations or information given orally or in writing, are not to be construed as an amendment or addition to the above warranty.
13. **Damage Limits: Etc.** SELLER SHALL NOT BE LIABLE FOR SPECIAL, INDIRECT OR CONSEQUENTIAL DAMAGES, LOSS OF PROFITS OR PRODUCTION OR COMMERCIAL LOSS IN ANY WAY CONNECTED WITH THE GOODS, WHETHER SUCH CLAIM IS BASED IN CONTRACT, WARRANTY, NEGLIGENCE OR STRICT LIABILITY. Further, in no event shall liability of Seller exceed the individual price of the Good on which liability is asserted.
14. **Indemnities.** Buyer shall indemnify and hold harmless Seller, its affiliates and its employees from and against all liabilities, losses, claims, costs and expenses (including attorney's fees and expenses) related to any claim, investigation, litigation or proceeding (whether or not Seller is a party) which arises or is alleged to arise from Buyer's acts or omissions under these Terms or in any way with respect to the Goods. Without limiting the foregoing, Buyer (at its own expense) shall indemnify and hold harmless Seller and defend or settle any action brought against Seller to the extent that it is based on a claim that any Good made to Buyer specifications infringed intellectual property rights of another party.
15. **Property: Confidentiality.** The intellectual property embodied in the Goods is the exclusive property of Seller and its affiliates and Buyer shall not attempt to duplicate it in any way without the written permission of Seller. Notwithstanding any charges to Buyer for engineering or tooling, all engineering and tooling shall remain the exclusive property of Seller. All information and materials supplied by Seller to Buyer relating to the Goods are confidential and proprietary, and Buyer shall limit distribution thereof to its trusted employees and strictly prevent disclosure to any third party.
16. **Miscellaneous.** (a) **Waiver.** No failure or delay by Seller in exercising any right and no course of dealing between Buyer and Seller shall operate as a waiver of rights by Seller. (b) **Assignment.** Buyer may not assign its rights hereunder without Seller's written consent. (c) **Amendment.** These Terms constitute the entire agreement between Buyer and Seller relating to the Goods, and no provision may be changed or waived unless in writing signed by the parties. (d) **Severability.** If any provision hereof is rendered ineffective or invalid, such provision shall not invalidate any other provision. (e) **Setoff.** Buyer shall have no right to set off any amounts against the amount owing in respect of this invoice. (f) As used herein, "including" means "including without limitation".

Certain Precautions on Specifications and Use

1. **Suitability of Use.** Seller shall not be responsible for conformity with any standards, codes or regulations which apply to the combination of the Good in the Buyer's application or use of the Good. At Buyer's request, Seller will provide applicable third party certification documents identifying ratings and limitations of use which apply to the Good. This information by itself is not sufficient for a complete determination of the suitability of the Good in combination with the end product, machine, system, or other application or use. The following are some examples of applications for which particular attention must be given. This is not intended to be an exhaustive list of all possible uses of this Good, nor is it intended to imply that the uses listed may be suitable for this Good:
 - (i) Outdoor use, uses involving potential chemical contamination or electrical interference, or conditions or uses not described in this document.
 - (ii) Energy control systems, combustion systems, railroad systems, aviation systems, medical equipment, amusement machines, vehicles, safety equipment, and installations subject to separate industry or government regulations.
 - (iii) Systems, machines and equipment that could present a risk to life or property. Please know and observe all prohibitions of use applicable to this Good.

NEVER USE THE PRODUCT FOR AN APPLICATION INVOLVING SERIOUS RISK TO LIFE OR PROPERTY WITHOUT ENSURING THAT THE SYSTEM AS A WHOLE HAS BEEN DESIGNED TO ADDRESS THE RISKS, AND THAT THE SELLER'S PRODUCT IS PROPERLY RATED AND INSTALLED FOR THE INTENDED USE WITHIN THE OVERALL EQUIPMENT OR SYSTEM.
2. **Programmable Products.** Seller shall not be responsible for the user's programming of a programmable Good, or any consequence thereof.
3. **Performance Data.** Performance data given in this catalog is provided as a guide for the user in determining suitability and does not constitute a warranty. It may represent the result of Seller's test conditions, and the user must correlate it to actual application requirements. Actual performance is subject to the Seller's Warranty and Limitations of Liability.
4. **Change in Specifications.** Product specifications and accessories may be changed at any time based on improvements and other reasons. It is our practice to change part numbers when published ratings or features are changed, or when significant construction changes are made. However, some specifications of the Good may be changed without any notice. When in doubt, special part numbers may be assigned to fix or establish key specifications for your application. Please consult with your Seller's representative at any time to confirm actual specifications of purchased Good.
5. **Errors and Omissions.** The information in this catalog has been carefully checked and is believed to be accurate; however, no responsibility is assumed for clerical, typographical or proofreading errors, or omissions.

Complete "Terms and Conditions of Sale" for product purchase and use are on Omron's website at www.omron.com/oei – under the "About Us" tab, in the Legal Matters section.

ALL DIMENSIONS SHOWN ARE IN MILLIMETERS.

To convert millimeters into inches, multiply by 0.03937. To convert grams into ounces, multiply by 0.03527.



OMRON ELECTRONICS LLC

One Commerce Drive
Schaumburg, IL 60173

847-843-7900

For US technical support or other inquiries:

800-556-6766

OMRON CANADA, INC.

885 Milner Avenue
Toronto, Ontario M1B 5V8

416-286-6465

OMRON ON-LINE

Global - <http://www.omron.com>
USA - <http://www.omron.com/oei>
Canada - <http://www.omron.ca>