

General Description

BDE-BW2837 is a Wi-Fi 2.4GHz and 5GHz Dual-Band and Bluetooth & Bluetooth Low Energy (BLE) Dual-mode high throughput and extended range along with Wi-Fi and Bluetooth coexistence in a power-optimized design.



Key Features

General

- Wi-Fi 2.4GHz/5GHz Dual-Band and Bluetooth & BLE Dual-Mode.
- Integrates RF, Power Amplifiers (PAs), Clock, RF Switches, Filters, Passives, and Power Management
- Operating Temperature: -40°C to $+85^{\circ}\text{C}$
- Dimension: $13.3 \times 13.4 \times 2.0$ mm
- LGA-100 pin Package
- Certifications
- FCC ID: 2ABRU-BW2837, IC: 25657-BW2837, CE-RED compliant
- Wi-Fi-Bluetooth Single Antenna Coexistence

Bluetooth® and BLE

- Bluetooth 4.2 Secure Connection Compliant and
- CSA2 Support
- Host Controller Interface (HCI) Transport for
- Bluetooth Over UART
- Dedicated Audio Processor Support of SBC Encoding + A2DP
- Certified Bluetooth- and BLE Dual mode Stack
- BLE up to 10 low energy connections

Wi-Fi®

- WLAN Baseband Processor and RF Transceiver Support of IEEE Std 802.11a, 802.11b, 802.11g, and 802.11n
- 20- and 40-MHz SISO and 20-MHz 2×2 MIMO at 2.4 GHz for High Throughput: 80 Mbps (TCP), 100 Mbps (UDP)
- 2.4-GHz MRC Support for Extended Range and 5-GHz Diversity Capable
- Wi-Fi Direct Concurrent Operation (Multichannel, Multirole)
- Fully calibrated system (production calibration not required)
- Hardware-based encryption-decryption using 64-, 128-, and 256-bit WEP, TKIP, or AES keys
- Requirements for Wi-Fi-protected access (WPA and WPA2.0) and IEEE Std 802.11i (includes hardware-accelerated Advanced Encryption Standard [AES])
- Advanced coexistence scheme with Bluetooth and Bluetooth low energy wireless technology
- 4-bit SDIO host interface, including high speed (HS) and V3 modes
- Low Wi-Fi Power Consumption in Connected Idle ($< 800 \mu\text{A}$)
- Configurable Wake on WLAN Filters to Only Wake Up the System

Applications

- Internet of Things (IoT)
- Multimedia
- Home Electronics
- Home Appliances and White Goods
- Industrial and Home Automation
- Smart Gateway and Metering
- Video Conferencing
- Video Camera and Security

Contents

General Description	1		
Key Features.....	1		
Applications.....	1		
Contents.....	2		
1. References.....	3		
2. Block Diagram.....	4		
3. Terminal Configuration and Functions	5		
3.1 Pin Diagram.....	5		
3.2 Pin Attributes and Pin Multiplexing.....	5		
4. Specifications	8		
4.1 General Requirements and Operating Conditions	8		
4.1.1 Absolute Maximum Ratings	8		
4.1.2 ESD Ratings	8		
4.1.3 Recommended Operating Conditions	9		
4.1.4 External Digital Slow Clock Requirements	9		
4.2 WLAN Performance	10		
4.2.1 WLAN 2.4-GHz Receiver Characteristics	10		
4.2.2 WLAN 2.4-GHz Transmitter Power...	11		
4.2.3 WLAN 5-GHz Receiver Characteristics	12		
4.2.4 WLAN 5-GHz Transmitter Power....	12		
4.2.5 WLAN Power Consumption.....	13		
4.3 Bluetooth Performance	14		
4.3.1 BR, EDR Receiver Characteristics—In-Band Signals.....	14		
4.3.2 Bluetooth Transmitter, BR.....	15		
4.3.3 Bluetooth Transmitter, EDR	15		
4.3.4 Bluetooth Modulation, BR.....	15		
4.3.5 Bluetooth Modulation, EDR	16		
4.3.6 Bluetooth BR / EDR Power Consumption.....	16		
4.4 Bluetooth Low Energy Performance	17		
4.4.1 Receiver Characteristics – In-Band Signals	17		
4.4.2 Bluetooth low energy Transmitter Characteristics.....	17		
4.4.3 Bluetooth low energy Modulation Characteristics.....	17		
4.4.4 Bluetooth Low Energy Power Consumption	18		
5. Typical RF Parameters and Power Consumptions	19		
6. Power Management.....	20		
6.1 Internal DC-DCs.....	20		
6.2 Power-Up and Shut-Down States.....	20		
6.3 Chip Top-level Power-Up Sequence	21		
6.4 WLAN Power-Up Sequence	22		
6.5 Bluetooth-Bluetooth Low Energy Power-Up Sequence	22		
7. WLAN SDIO Transport Layer	23		
7.1 SDIO Default Rate Timing Specifications ...	23		
7.2 SDIO HS Switching Characteristics	24		
8. HCI UART Shared-Transport Layers for All Functional Blocks (Except WLAN)	26		
9. Bluetooth Codec-PCM (Audio) Timing Specifications	28		
10. Reference Design	29		
10.1 Block Diagram.....	29		
10.2 Typical Application Schematic	30		
10.3 Design Recommendations.....	31		
11. Baking and SMT Recommendations	33		
11.1 Baking Recommendations	33		
11.2 SMT Recommendations.....	33		
12. Mechanical Specifications	34		
12.1 Dimensions	34		
12.2 PCB Footprint	34		
12.3 Marking	35		
13. Packaging Information	36		
14. Ordering Information	37		
15. Revision History	37		

1. References

- [1] WL1837MOD Datasheet
https://www.ti.com/lit/ds/symlink/wl1837mod.pdf?ts=1618144492050&ref_url=https%253A%252F%252Fwww.ti.com%252Fproduct%252FWL1837MOD%253FkeyMatch%253DWL1837MOD%2526tsearch%253Dsearch-everything%2526usecase%253DGPN
- [2] WL18xx Module Hardware Integration Guide (Rev. B)
<https://www.ti.com/lit/ug/swru437b/swru437b.pdf?ts=1618116072326>
- [3] WL1837MODCOM8I WLAN MIMO and BT Module EVB for TI Sitara Platform (Rev. A)
<https://www.ti.com/lit/ug/swru382a/swru382a.pdf?ts=1618129156502>

2. Block Diagram

BDE-BW2837 is a Wi-Fi 2.4GHz and 5GHz Dual-Band and Bluetooth & Bluetooth Low Energy (BLE) Dual-mode high throughput and extended range along with Wi-Fi and Bluetooth coexistence in a power-optimized design.

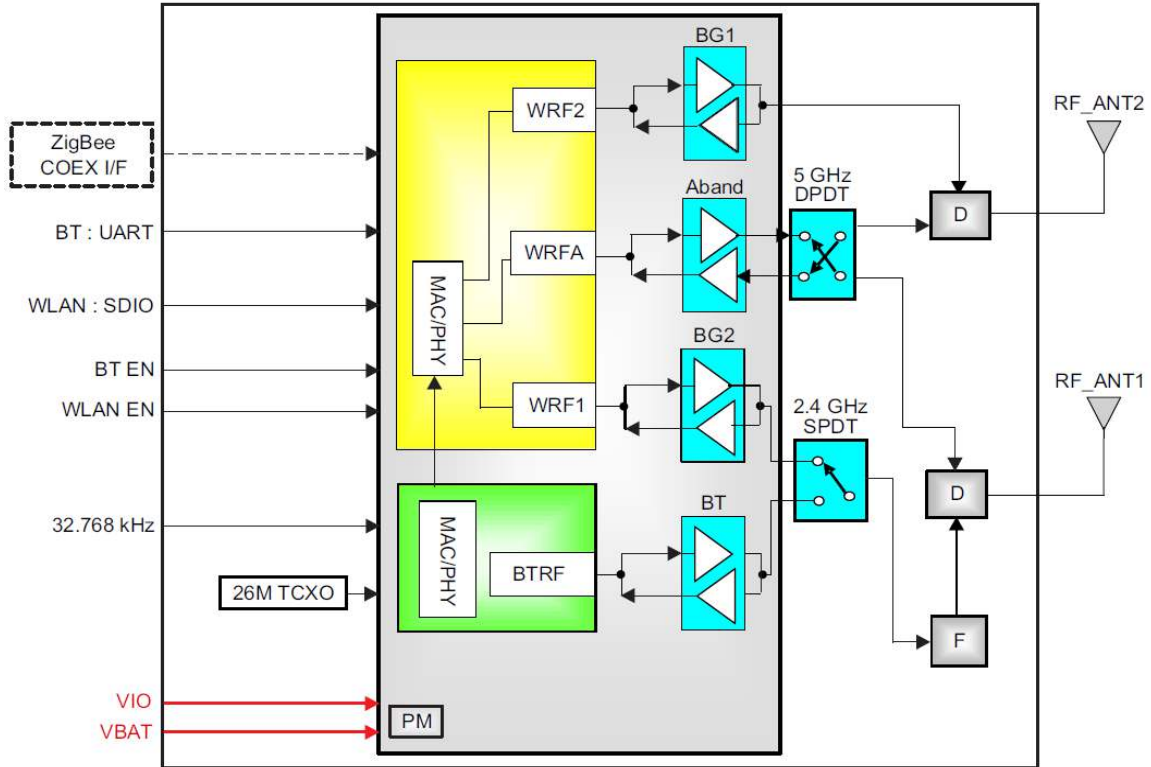

NOTE: Dashed lines indicate optional configurations and are not applied by default.

Figure 2-1. BDE-BW2837 Module Block Diagram

3. Terminal Configuration and Functions

3.1 Pin Diagram

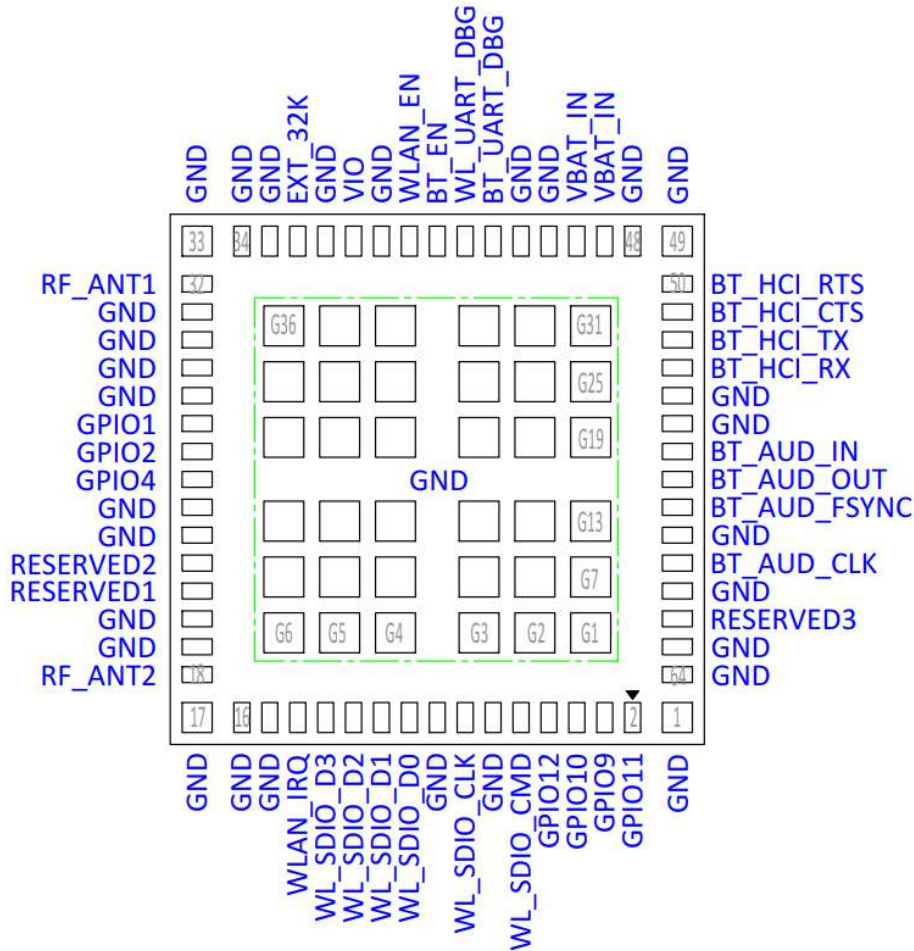

Figure 3-1. Pin Diagram Bottom View

3.2 Pin Attributes and Pin Multiplexing

Table 3-1. Pin Description

Pin #	Pin Name	Type	Shut Down State ⁽¹⁾	After Power Up ⁽¹⁾	Voltage Level	Description
1	GND	GND			-	Ground
2	GPIO11	I/O	PD	PD	1.8V	Reserved for future use. NC if not used.
3	GPIO9	I/O	PD	PD	1.8V	Reserved for future use. NC if not used.
4	GPIO10	I/O	PU	PU	1.8V	Reserved for future use. NC if not used.
5	GPIO12	I/O	PU	PU	1.8V	Reserved for future use. NC if not used.
6	WL_SDIO_CMD	I/O	HiZ	HiZ	1.8V	WLAN SDIO Command ⁽²⁾
7	GND	GND			-	Ground
8	WL_SDIO_CLK	I	HiZ	HiZ	1.8V	WLAN SDIO Clock.

Pin #	Pin Name	Type	Shut Down State ⁽¹⁾	After Power Up ⁽¹⁾	Voltage Level	Description
						Must be driven by the host.
9	GND	GND			-	Ground
10	WL_SDIO_D0	I/O	HiZ	HiZ	1.8V	WLAN SDIO Data bit 0 ⁽²⁾
11	WL_SDIO_D1	I/O	HiZ	HiZ	1.8V	WLAN SDIO Data bit 1 ⁽²⁾
12	WL_SDIO_D2	I/O	HiZ	HiZ	1.8V	WLAN SDIO Data bit 2 ⁽²⁾
13	WL_SDIO_D3	I/O	HiZ	PU	1.8V	WLAN SDIO Data bit 3. Changes state to PU at WL_EN or BT_EN assertion for card detects. Later disabled by software during initialization. ⁽²⁾
14	WLAN_IRQ	O	PD	0	1.8V	SDIO available, interrupt out. Active high. (For WL_RS232_TX/RX pull up is at power up.) Set to rising edge (active high) on power up. The Wi - Fi interrupt line can be configured by the driver according to the IRQ configuration (Polarity / Level / Edge).
15	GND	GND			-	Ground
16	GND	GND			-	Ground
17	GND	GND			-	Ground
18	RF_ANT2	ANA			-	WLAN 2.4GHz RF Port. NC if not used.
19	GND	GND			-	Ground
20	GND	GND			-	Ground
21	RESERVED1	I	PD	PD	1.8V	Reserved for future use. NC if not used.
22	RESERVED2	I	PD	PD	1.8V	Reserved for future use. NC if not used.
23	GND	GND			-	Ground
24	GND	GND			-	Ground
25	GPIO4	I/O	PD	PD	1.8V	Reserved for future use. NC if not used.
26	GPIO2	I/O	PD	PD	1.8V	WL_RS232_RX (when WLAN_IRQ = 1 at power up)
27	GPIO1	I/O	PD	PD	1.8V	WL_RS232_TX (when WLAN_IRQ = 1 at power up)
28	GND	GND			-	Ground
29	GND	GND			-	Ground
30	GND	GND			-	Ground
31	GND	GND			-	Ground
32	RF_ANT1	ANA			-	WLAN / Bluetooth 2.4GHz RF Port
33	GND	GND			-	Ground
34	GND	GND			-	Ground
35	GND	GND			-	Ground
36	EXT_32K	ANA			-	Input sleep clock: 32.768 kHz
37	GND	GND			-	Ground

Pin #	Pin Name	Type	Shut Down State ⁽¹⁾	After Power Up ⁽¹⁾	Voltage Level	Description
38	VIO	POW	PD	PD	1.8V	Connect to 1.8V external VIO
39	GND	GND			-	Ground
40	WLAN_EN	I	PD	PD	1.8V	Mode setting: high = enable
41	BT_EN	I	PD	PD	1.8V	Mode setting: high =enable. If Bluetooth is not used, connect to ground.
42	WL_UART_DBG	O	PU	PU	1.8V	Option: WLAN logger
43	BT_UART_DEB UG	O	PU	PU	1.8V	Option: Bluetooth logger
44	GND	GND			-	Ground
45	GND	GND			-	Ground
46	VBAT_IN	POW			VBAT	Power supply input, 2.9 to 4.8 V
47	VBAT_IN	POW			VBAT	Power supply input, 2.9 to 4.8 V
48	GND	GND			-	Ground
49	GND	GND			-	Ground
50	BT_HCI_RTS	O	PU	PU	1.8V	UART RTS to host. NC if not used.
51	BT_HCI_CTS	I	PU	PU	1.8V	UART CTS to host. NC if not used.
52	BT_HCI_TX	O	PU	PU	1.8V	UART TX to host. NC if not used.
53	BT_HCI_RX	I	PU	PU	1.8V	UART RX to host. NC if not used.
54	GND	GND			-	Ground
55	GND	GND			-	Ground
56	BT_AUD_IN	I	PD	PD	1.8V	Bluetooth PCM/I2S bus. Data in. NC if not used.
57	BT_AUD_OUT	O	PD	PD	1.8V	Bluetooth PCM/I2S bus. Data in. NC if not used.
58	BT_AUD_FSYN C	I/O	PD	PD	1.8V	Bluetooth PCM/I2S bus. Data in. NC if not used.
59	GND	GND			-	Ground
60	BT_AUD_CLK	I/O	PD	PD	1.8V	Bluetooth PCM/I2S bus. Data in. NC if not used.
61	GND	GND			-	Ground
62	RESERVED3	O	PD	PD	1.8V	Reserved for future use. NC if not used. Option: External TCXO.
63	GND	GND			-	Ground
64	GND	GND			-	Ground
G1~G36	GND	GND			-	Ground

(1) PU = pullup; PD = pulldown.

(2) Host must provide PU using a 10-K resistor for all non-CLK SDIO signals.

4. Specifications

4.1 General Requirements and Operating Conditions

All specifications are based on typical values $V_{BAT} = 3.7\text{ V}$, $V_{IO} = 1.8\text{ V}$, over operating free-air temperature range unless otherwise noted.

4.1.1 Absolute Maximum Ratings (1)

PARAMETER	MIN	MAX	UNIT
V_{BAT}		4.8 ⁽²⁾	V
V_{IO}	-0.5	2.1	V
Input voltage to analog pins	-0.5	2.1	V
Input voltage limits (CLK_IN)	-0.5	VDD_IO	V
Input voltage to all other pins	-0.5	(VDD_IO + 0.5)	V
Operating ambient temperature	-40	85 ⁽³⁾	°C
Storage temperature, T_{stg}	-40	85	°C

- (1) Stresses beyond those listed under Absolute Maximum Ratings may cause permanent damage to the device. These are stress ratings only and functional operation of the device at these or any other conditions beyond those indicated under Operating Conditions is not implied. Exposure to absolute-maximum-rated conditions for extended periods may affect device reliability.
- (2) 4.8 V cumulative to 2.33 years, including charging dips and peaks
- (3) In the system, a control mechanism exists to ensure $T_i < 125^\circ\text{C}$. When T_i approaches this threshold, the control mechanism manages the transmitter patterns.

4.1.2 ESD Ratings

		VALUE	UNIT
VESD Electrostatic discharge	Human body model (HBM), per ANSI/ESDA/JEDEC JS001 ⁽¹⁾	±1000	V
	Charged device model (CDM), per JEDEC specification JESD22-C101 ⁽²⁾	±250	

- (1) JEDEC document JEP155 states that 500-V HBM allows safe manufacturing with a standard ESD control process.
- (2) JEDEC document JEP157 states that 250-V CDM allows safe manufacturing with a standard ESD control process.

4.1.3 Recommended Operating Conditions

PARAMETER			MIN	TYP	MAX	UNIT
V _{BAT} ⁽¹⁾	DC supply range for all modes		2.9	3.7	4.8	V
V _{IO}	1.8-V I/O ring power supply voltage		1.62	1.8	1.95	V
V _{IH}	I/O high-level input voltage		0.65 × VDD _{IO}		VDD _{IO}	V
V _{IL}	I/O low-level input voltage		0	0.35 × VDD _{IO}		V
V _{IH,EN}	Enable inputs high-level input voltage		1.365	VDD _{IO}		V
V _{IL,EN}	Enable inputs low-level input voltage		0	0.4		V
V _{OH}	High-level output voltage	@ 4 mA	VDD _{IO} - 0.45		VDD _{IO}	V
V _{OL}	Low-level output voltage	@ 4 mA	0	0.45		V
T _r , T _f	Input transitions time T _r , T _f from 10% to 90% (digital I/O) ⁽²⁾		1	10		ns
T _r	Output rise time from 10% to 90% (digital pins) ⁽²⁾	C _L < 25 pF			5.3	ns
T _f	Output fall time from 10% to 90% (digital pins) ⁽²⁾	C _L < 25 pF			4.9	ns
	Ambient operating temperature		-40	85		°C
Maximum power dissipation	WLAN operation				2.8	W
	Bluetooth operation				0.2	

(1) 4.8 V is applicable only for 2.33 years (30% of the time). Otherwise, maximum V_{BAT} must not exceed 4.3 V.

(2) Applies to all digital lines except SDIO, UART, I2C, PCM and slow clock lines

4.1.4 External Digital Slow Clock Requirements

The supported digital slow clock is 32.768 kHz digital (square wave). All core functions share a single input.

		CONDITION	MIN	TYP	MAX	UNIT
	Input slow clock frequency		32768			Hz
	Input slow clock accuracy (Initial + temp + aging)	WLAN, Bluetooth			±250	ppm
T _r , T _f	Input transition time (10% to 90%)				200	ns
	Frequency input duty cycle		15%	50%	85%	
V _{IH} , V _{IL}	Input voltage limits	Square wave, DC-coupled	0.65 × VDD _{IO}		VDD _{IO}	V _{peak}
			0	0.35 × VDD _{IO}		
	Input impedance		1			MΩ
	Input capacitance				5	pF

4.2 WLAN Performance

All specifications are over operating free-air temperature range. All RF and performance numbers are aligned to the module pin (unless otherwise noted).

4.2.1 WLAN 2.4-GHz Receiver Characteristics

PARAMETER	CONDITION	MIN	TYP	MAX	UNIT
RF_ANT1 pin 2.4-GHz SISO					
Operation frequency range		2412		2484	MHz
Sensitivity: 20-MHz bandwidth. At < 10% PER limit	1 Mbps DSSS		-95.0		dBm
	2 Mbps DSSS		-92.0		
	5.5 Mbps CCK		-89.2		
	11 Mbps CCK		-86.3		
	6 Mbps OFDM		-91.0		
	9 Mbps OFDM		-89.0		
	12 Mbps OFDM		-88.0		
	18 Mbps OFDM		-85.5		
	24 Mbps OFDM		-82.5		
	36 Mbps OFDM		-79.0		
	48 Mbps OFDM		-74.0		
	54 Mbps OFDM		-72.5		
	MCS0 MM 4K		-89.3		
	MCS1 MM 4K		-86.5		
	MCS2 MM 4K		-84.5		
	MCS3 MM 4K		-81.5		
	MCS4 MM 4K		-78.0		
	MCS5 MM 4K		-73.5		
	MCS6 MM 4K		-71.5		
	MCS7 MM 4K		-70.0		
MCS0 MM 4K 40 MHz		-86.0			
MCS7 MM 4K 40 MHz		-66.3			
MCS0 MM 4K MRC		-91.0			
MCS7 MM 4K MRC		-73.0			
MCS13 MM 4K		-70.0			
MCS14 MM 4K		-69.0			
MCS15 MM 4K		-68.3			
Maximum input level	OFDM	-20.0	-10.0		dBm
	CCK	-10.0	-6.0		
	DSSS	-4.0	-1.0		
Adjacent channel rejection: Sensitivity level +3 dB for OFDM; Sensitivity level +6 dB for 11b	2 Mbps DSSS	42.0			dB
	11 Mbps CCK	38.0			
	54 Mbps OFDM	2.0			
RX leakage			-70		dBm
PER floor			1.0%		
RSSI accuracy				±3	dB

4.2.2 WLAN 2.4-GHz Transmitter Power

PARAMETER	CONDITION ⁽¹⁾	MIN	TYP	MAX	UNIT
RF_ANT1 Pin 2.4-GHz SISO					
Output Power: Maximum RMS output power measured at 1 dB from IEEE spectral mask or EVM ⁽²⁾	1 Mbps DSSS		17.3		dBm
	2 Mbps DSSS		17.3		
	5.5 Mbps CCK		17.3		
	11 Mbps CCK		17.3		
	6 Mbps OFDM		17.1		
	9 Mbps OFDM		17.1		
	12 Mbps OFDM		17.1		
	18 Mbps OFDM		17.1		
	24 Mbps OFDM		16.2		
	36 Mbps OFDM		15.3		
	48 Mbps OFDM		14.6		
	54 Mbps OFDM		13.8		
	MCS0 MM		16.1		
	MCS1 MM		16.1		
	MCS2 MM		16.1		
	MCS3 MM		16.1		
	MCS4 MM		15.3		
	MCS5 MM		14.6		
	MCS6 MM		13.8		
	MCS7 MM ⁽³⁾		12.6		
MCS0 MM 40 MHz		14.8			
MCS7 MM 40 MHz		11.3			
RF_ANT1 + RF_ANT2 MIMO					
	MCS12 (BW2837)		18.5		dBm
	MCS13 (BW2837)		17.4		
	MCS14 (BW2837)		14.5		
	MCS15 (BW2837)		13.4		
RF_ANT1 + RF_ANT2					
Operation frequency range		2412		2484	MHz
Return loss			-10.0		dB
Reference input impedance			50.0		Ω

(1) Maximum transmitter power (TP) degradation of up to 30% is expected, starting from 80°C ambient temperature on MIMO operation

(2) Regulatory constraints limit module output power to the following:

- Channel 14 is used only in Japan; to keep the channel spectral shaping requirement, the power is limited: 14.5 dBm.
- Channels 1, 11 @ OFDM legacy and HT 20-MHz rates: 12 dBm
- Channels 1, 11 @ HT 40-MHz rates: 10 dBm
- Channel 7 @ HT 40-MHz lower rates: 10 dBm
- Channel 5 @ HT 40-MHz upper rates: 10 dBm
- All 11B rates are limited to 16 dBm to comply with the ETSI PSD 10 dBm/MHz limit.
- All OFDM rates are limited to 16.5 dBm to comply with the ETSI EIRP 20 dBm limit.

(3) To ensure compliance with the EVM conditions specified in the PHY chapter of IEEE Std 802.11™ – 2012:

- MCS7 20 MHz channel 12 output power is 2 dB lower than the typical value.
- MCS7 20 MHz channel 8 output power is 1 dB lower than the typical value.

4.2.3 WLAN 5-GHz Receiver Characteristics

PARAMETER	CONDITION	MIN	TYP	MAX	UNIT
RF_ANT1 or RF_ANT2					
Operation frequency range		4910.0		5825.0	MHz
Sensitivity: 20-MHz bandwidth. At < 10% PER limit	6 Mbps OFDM 1K		-92.5		dBm
	9 Mbps OFDM 1K		-90.5		
	12 Mbps OFDM 1K		-90.0		
	18 Mbps OFDM 1K		-87.5		
	24 Mbps OFDM 1K		-84.5		
	36 Mbps OFDM 1K		-81.0		
	48 Mbps OFDM 1K		-76.5		
	54 Mbps OFDM 1K		-74.6		
	MCS0 MM 4K		-91.4		
	MCS1 MM 4K		-88.0		
	MCS2 MM 4K		-86.0		
	MCS3 MM 4K		-83.0		
	MCS4 MM 4K		-79.8		
	MCS5 MM 4K		-75.5		
	MCS6 MM 4K		-74.0		
	MCS7 MM 4K		-72.4		
	MCS0 MM 4K 40 MHz		-88.5		
MCS7 MM 4K 40 MHz		-69.3			
Maximum input level	OFDM	-30.0	-15.0		dBm
Adjacent channel rejection sensitivity +3 dB	OFDM54	2.0			dBm
RX LO leakage			-52.0		dBm
PER floor			1.0%	2.0%	
RSSI accuracy			±3		dB

4.2.4 WLAN 5-GHz Transmitter Power ⁽¹⁾

PARAMETER	CONDITION ⁽²⁾	MIN	TYP	MAX	UNIT
RF_ANT1 or RF_ANT2					
Operation frequency range		4920		5825	MHz
RMS output power complies with IEEE mask and EVM requirements	6 Mbps OFDM		18.0		dBm
	9 Mbps OFDM		18.0		
	12 Mbps OFDM		18.0		
	18 Mbps OFDM		18.0		
	24 Mbps OFDM		17.4		
	36 Mbps OFDM		16.5		
	48 Mbps OFDM		15.8		
	54 Mbps OFDM		14.5		
	MCS0 MM		18.0		
	MCS1 MM 4K		18.0		
	MCS2 MM 4K		18.0		
	MCS3 MM 4K		18.0		
	MCS4 MM 4K		16.5		
	MCS5 MM 4K		15.8		
	MCS6 MM 4K		14.5		
	MCS7 MM 4K		13.0		
	MCS0 MM 40 MHz		16.5		
MCS7 MM 40 MHz		12.0			
Output power resolution			0.125		dB

PARAMETER	CONDITION ⁽²⁾	MIN	TYP	MAX	UNIT
Return loss			-10.0		dB
Reference input impedance			50.0		Ω

(1) All RF and performance numbers are aligned to the module pin.

(2) Maximum TP degradation of up to 30% is expected, starting from 80°C ambient temperature on 5-GHz TX operation.

4.2.5 WLAN Power Consumption ⁽¹⁾

PARAMETER	SPECIFICATION	TYP (AVG) -25°C	UNIT
Receiver	Low-power mode (LPM) 2.4-GHz RX SISO20 single chain	49	mA
	2.4 GHz RX search SISO20	58	
	2.4-GHz RX search MIMO20	74	
	2.4-GHz RX search SISO40	63	
	2.4-GHz RX 20 M SISO 11 CCK	60	
	2.4-GHz RX 20 M SISO 6 OFDM	61	
	2.4-GHz RX 20 M SISO MCS7	69	
	2.4-GHz RX 20 M MRC 1 DSSS	74	
	2.4-GHz RX 20 M MRC 6 OFDM	81	
	2.4-GHz RX 20 M MRC 54 OFDM	85	
	2.4-GHz RX 40-MHz MCS7	81	
	5-GHz RX 20-MHz OFDM6	68	
	5-GHz RX 20-MHz MCS7	77	
	5-GHz RX 40-MHz MCS7	85	
Transmitter ⁽²⁾	2.4-GHz TX 20 M SISO 6 OFDM	285	mA
	2.4-GHz TX 20 M SISO 11 CCK	283	
	2.4-GHz TX 20 M SISO 54 OFDM	247	
	2.4-GHz TX 20 M SISO MCS7	238	
	2.4-GHz TX 20 M MIMO MCS15	510	
	2.4-GHz TX 40 M SISO MCS7	243	
	5-GHz TX 20 M SISO 6 OFDM	366	
	5-GHz TX 20 M SISO 54 OFDM	329	
	5-GHz TX 20 M SISO MCS7	324	
5-GHz TX 40 M SISO MCS7	332		

(1) All RF and performance numbers are aligned to the module pin.

(2) Numbers reflect the typical current consumption at maximum output power per rate.

4.3 Bluetooth Performance

All specifications are over operating free-air temperature range (unless otherwise noted)

4.3.1 BR, EDR Receiver Characteristics—In-Band Signals ⁽¹⁾

PARAMETER	CONDITION	MIN	TYP	MAX	UNIT
Bluetooth BR, EDR operation frequency range		2402		2480	MHz
Bluetooth BR, EDR channel spacing			1		MHz
Bluetooth BR, EDR input impedance			50		Ω
Bluetooth BR, EDR sensitivity ⁽²⁾ dirty TX on	BR, BER = 0.1%		-92.2		dBm
	EDR2, BER = 0.01%		-91.7		
	EDR3, BER = 0.01%		-84.7		
Bluetooth EDR BER floor at sensitivity + 10 dB Dirty TX off (for 1,600,000 bits)	EDR2	1e-6			
	EDR3	1e-6			
Bluetooth BR, EDR maximum usable input power	BR, BER = 0.1%	-5.0			dBm
	EDR2, BER = 0.1%	-15.0			
	EDR3, BER = 0.1%	-15.0			
Bluetooth BR intermodulation	Level of interferers for n = 3, 4, and 5	-36.0	-30.0		dBm
Bluetooth BR, EDR C/I performance Numbers show wanted signal-to-interfering-signal ratio. Smaller numbers indicate better C/I performances (Image frequency = -1 MHz)	BR, co-channel				10
	EDR, co-channel	EDR2			12
		EDR3			20
	BR, adjacent ±1 MHz				-3.0
	EDR, adjacent ±1 MHz, (image)	EDR2			-3.0
		EDR3			2.0
	BR, adjacent +2 MHz				-33.0
	EDR, adjacent +2 MHz	EDR2			-33.0
		EDR3			-28.0
	BR, adjacent -2 MHz				-20.0
	EDR, adjacent -2 MHz	EDR2			-20.0
		EDR3			-13.0
	BR, adjacent ≥ ±3 MHz				-42.0
EDR, adjacent ≥ ±3 MHz	EDR2			-42.0	
	EDR3			-36.0	
Bluetooth BR, EDR RF return loss			-10.0		dB

(1) All RF and performance numbers are aligned to the module pin.

(2) Sensitivity degradation up to -3 dB may occur due to fast clock harmonics with dirty TX on.

4.3.2 Bluetooth Transmitter, BR ⁽¹⁾

PARAMETER	MIN	TYP	MAX	UNIT
BR RF output power ⁽²⁾	$V_{BAT} \geq 3 V^{(3)}$	11.7		dBm
	$V_{BAT} < 3 V^{(3)}$	7.2		
BR gain control range		30.0		dB
BR power control step		5.0		dB
BR adjacent channel power $ M-N = 2$		-43.0		dBm
BR adjacent channel power $ M-N > 2$		-48.0		dBm

- (1) All RF and performance numbers are aligned to the module pin.
- (2) Values reflect maximum power. Reduced power is available using a vendor-specific (VS) command.
- (3) VBAT is measured with an on-chip ADC that has an accuracy error of up to 5%.

4.3.3 Bluetooth Transmitter, EDR ⁽¹⁾

PARAMETER	MIN	TYP	MAX	UNIT
EDR output power ⁽²⁾	$V_{BAT} \geq 3 V^{(3)}$	7.2		dBm
	$V_{BAT} < 3 V^{(3)}$	5.2		
EDR gain control range		30		dB
EDR power control step		5		dB
EDR adjacent channel power $ M-N = 1$		-36		dBc
EDR adjacent channel power $ M-N = 2$		-30		dBm
EDR adjacent channel power $ M-N > 2$		-42		dBm

- (1) All RF and performance numbers are aligned to the module pin.
- (2) Values reflect default maximum power. Maximum power can be changed using a Vendor-Specific VS command.
- (3) VBAT is measured with an on-chip ADC that has an accuracy error of up to 5%.

4.3.4 Bluetooth Modulation, BR ⁽¹⁾

CHARACTERISTICS	CONDITION ⁽²⁾		MIN	TYP	MAX	UNIT
BR -20-dB bandwidth				925	995	kHz
BR modulation characteristics	$\Delta f1_{avg}$	Mod data = 4 1s, 4 0s: 111100001111...	145	160	170	kHz
	$\Delta f2_{max} \geq$ limit for at least 99.9% of all $\Delta f2_{max}$	Mod data = 1010101...	120	130		kHz
	$\Delta f2_{avg}, \Delta f1_{avg}$		85%	88%		
BR carrier frequency drift	One-slot packet		-25		25	kHz
	Three- and five-slot packet		-35		35	kHz
BR drift rate	$ f_{k+5} - f_k , k = 0 \dots max$				15	kHz/50 μ s
BR initial carrier frequency tolerance ⁽³⁾	$f_0 - f_{TX}$		± 75		± 75	kHz

- (1) All RF and performance numbers are aligned to the module pin.
- (2) Performance values reflect maximum power.
- (3) Numbers include XTAL frequency drift over temperature and aging.

4.3.5 Bluetooth Modulation, EDR ⁽¹⁾

PARAMETER ⁽²⁾	CONDITION	MIN	TYP	MAX	UNIT
EDR carrier frequency stability		-5		5	kHz
EDR initial carrier frequency tolerance ⁽³⁾		±75		±75	kHz
EDR RMS DEVM	EDR2		4%	15%	
	EDR3		4%	10%	
EDR 99% DEVM	EDR2			30%	
	EDR3			20%	
EDR peak DEVM	EDR2		9%	25%	
	EDR3		9%	18%	

(1) All RF and performance numbers are aligned to the module pin.

(2) Performance values reflect maximum power.

(3) Numbers include XTAL frequency drift over temperature and aging.

4.3.6 Bluetooth BR / EDR Power Consumption

Current is measured at output power as follows: BR at 11.7 dBm; EDR at 7.2 dBm.

USE CASE ⁽¹⁾⁽²⁾	TYP	UNIT
BR voice HV3 + sniff	11.6	mA
EDR voice 2-EV3 no retransmission + sniff	5.9	mA
Sniff 1 attempt 1.28 s	178.0	μA
EDR A2DP EDR2 (master). SBC high quality – 345 kbps	10.4	mA
EDR A2DP EDR2 (master). MP3 high quality – 192 kbps	7.5	mA
Full throughput ACL RX: RX-2DH5 ⁽³⁾⁽⁴⁾	18.0	mA
Full throughput BR ACL TX: TX-DH5 ⁽⁴⁾	50.0	mA
Full throughput EDR ACL TX: TX-2DH5 ⁽⁴⁾	33.0	mA
Page scan or inquiry scan (scan interval is 1.28 s or 11.25 ms, respectively)	253.0	μA
Page scan and inquiry scan (scan interval is 1.28 s and 2.56 s, respectively)	332.0	μA

(1) The role of Bluetooth in all scenarios except A2DP is slave.

(2) CL1P5 PA is connected to V_{BAT}, 3.7 V.

(3) ACL RX has the same current in all modulations.

(4) Full throughput assumes data transfer in one direction.

4.4 Bluetooth Low Energy Performance

4.4.1 Receiver Characteristics – In-Band Signals ⁽¹⁾

PARAMETER	CONDITION ⁽²⁾	MIN	TYP	MAX	UNIT
Bluetooth low energy operation frequency range		2402		2480	MHz
Bluetooth low energy channel spacing			2		MHz
Bluetooth low energy input impedance			50		Ω
Bluetooth low energy sensitivity ⁽³⁾ Dirty TX on			-92.2		dBm
Bluetooth low energy maximum usable input power		-5			dBm
Bluetooth low energy intermodulation characteristics	Level of interferers. For n = 3, 4, 5	-36	-30		dBm
Bluetooth low energy C/I performance. Note: Numbers show wanted signal-to-interfering-signal ratio. Smaller numbers indicate better C/I performance. Image = -1 MHz	low energy, co-channel			12	dB
	low energy, adjacent ±1 MHz			0	
	low energy, adjacent +2 MHz			-38	
	low energy, adjacent -2 MHz			-15	
	low energy, adjacent ≥ ±3 MHz			-40	

- (1) All RF and performance numbers are aligned to the module pin.
- (2) BER of 0.1% corresponds to PER of 30.8% for a minimum of 1500 transmitted packets, according to the Bluetooth low energy test specification.
- (3) Sensitivity degradation of up to -3 dB can occur due to fast clock harmonics.

4.4.2 Bluetooth low energy Transmitter Characteristics ⁽¹⁾

PARAMETER		MIN	TYP	MAX	UNIT
Bluetooth low energy RF output power ⁽²⁾	V _{BAT} ≥ 3 V ⁽³⁾		7.0		dBm
	V _{BAT} < 3 V ⁽³⁾		7.0		
Bluetooth low energy adjacent channel power M-N = 2			-51.0		dBm
Bluetooth low energy adjacent channel power M-N > 2			-54.0		dBm

- (1) All RF and performance numbers are aligned to the module pin.
- (2) Bluetooth low energy power is restricted to comply with the ETSI 10-dBm EIRP limit requirement.
- (3) VBAT is measured with an on-chip ADC that has an accuracy error of up to 5%.

4.4.3 Bluetooth low energy Modulation Characteristics ⁽¹⁾

CHARACTERISTICS	CONDITION ⁽²⁾		MIN	TYP	MAX	UNIT
Bluetooth low energy modulation characteristics	Δf1avg	Mod data = four 1s and four 0s: 111100001111...	240	250	260	kHz
	Δf2max ≥ limit for at least 99.9% of all	Mod data = 1010101...	195	215		
	Δf2max					
	Δf2avg, Δf1avg		85%	90%		
Bluetooth low energy carrier frequency drift	f0 - fn , n = 2,3 K		-25		25	kHz
Bluetooth low energy drift rate	f1 - f0 and fn - fn-5 , n = 6,7.... K				15	kHz/50 μs
Bluetooth low energy initial carrier frequency tolerance ⁽³⁾	fn - fTX		-75		+75	kHz

- (1) All RF and performance numbers are aligned to the module pin.
- (2) Performance values reflect maximum power.
- (3) Numbers include XTAL frequency drift over temperature and aging.

4.4.4 Bluetooth Low Energy Power Consumption

All current measured at output power of 6.5 dBm

USE CASE ⁽¹⁾	TYP	UNIT
Advertising, not connectable ⁽²⁾	131	μA
Advertising, discoverable ⁽²⁾	143	μA
Scanning ⁽³⁾	266	μA
Connected, master role, 1.28-s connect interval ⁽⁴⁾	124	μA
Connected, slave role, 1.28-s connect interval ⁽⁴⁾	132	μA

(1) CL1p% PA is connected to V_{BAT} , 3.7 V.

(2) Advertising in all three channels, 1.28-s advertising interval, 15 bytes advertise data

(3) Listening to a single frequency per window, 1.28-s scan interval, 11.25-ms scan window

(4) Zero slave connection latency, empty TX and RX LL packets

5. Typical RF Parameters and Power Consumptions

Table 5-1. WLAN Performance Parameters

WLAN ⁽¹⁾	CONDITIONS	SPECIFICATION (TYP)	UNIT
Maximum TX power, 5 GHz (OFDM6)	6-Mbps OFDM	18	dBm
Maximum TX power, 2.4 GHz (1DSSS)	1-Mbps DSSS	16.5	dBm
Minimum sensitivity, 5 GHz (OFDM6)	6-Mbps OFDM	-92.5	dBm
Minimum sensitivity, 2.4GHz (1DSSS)	1-Mbps DSSS	-95	dBm
Sleep current	Leakage, firmware retained	160	IJA
Connected IDLE	No traffic IDLE connect	750	IJA
RX search	2.4-GHz SISO 20	58	mA
RX current (SIS020)	MCS7, 2.4 GHz	69	mA
RX current (SIS020)	MCS7, 5 GHz	77	mA
TX current (SIS020)	MCS7, 2.4 GHz	238	mA
TX current (SIS020)	MCS7, 5 GHz	324	mA

(1) System design power scheme must comply with both peak and average TX bursts.

Table 5-2. Bluetooth Performance Parameters

BLUETOOTH	CONDITIONS	SPECIFICATION (TYP)	UNIT
Maximum TX power	GFSK	11.7	dBm
Minimum sensitivity	GFSK	-92.2	dBm
Sniff	1 attempt, 1.28 s (+4 dBm)	178	μA
Page or inquiry	1.28-s interrupt, 11.25-ms scan window (+4 dBm)	253	μA
A2DP	MP3 high quality 192 kbps (+4 dBm)	7.5	mA

Table 5-3. Shutdown and Sleep Currents

PARAMETER	POWER SUPPLY CURRENT	TYP	UNIT
Shutdown mode All functions shut down	VBAT	10	μA
	VIO	2	
WLAN sleep mode	VBAT	160	μA
	VIO	60	
Bluetooth sleep mode	VBAT	110	μA
	VIO	60	

6. Power Management

6.1 Internal DC-DCs

The device incorporates three internal DC-DCs (switched-mode power supplies) to provide efficient internal supplies, derived from V_{BAT} .

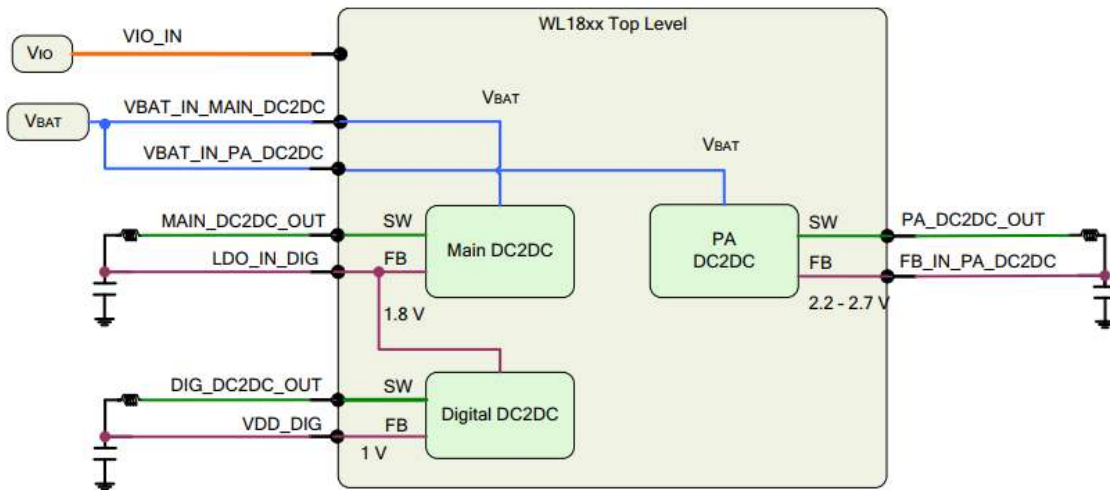

Figure 6-1. Internal DC-DCs

6.2 Power-Up and Shut-Down States

The correct power-up and shut-down sequences must be followed to avoid damage to the device.

While V_{BAT} or V_{IO} or both are de-asserted, no signals should be driven to the device. The only exception is the slow clock that is a fail-safe $1/0$.

While V_{BAT} , V_{IO} , and slow clock are fed to the device, but WL_EN is de-asserted (low), the device is in SHUTDOWN state. In SHUTDOWN state all functional blocks, internal DC-DCs, clocks, and LDOs are disabled.

To perform the correct power-up sequence, assert (high) WL_EN . The internal DC-DCs, LDOs, and clock start to ramp and stabilize. Stable slow clock, V_{IO} , and V_{BAT} are prerequisites to the assertion of one of the enable signals.

To perform the correct shut-down sequence, de-assert (low) WL_EN while all the supplies to the device (V_{BAT} , V_{IO} , and slow clock) are still stable and available. The supplies to the chip (V_{BAT} and V_{IO}) can be de-asserted only after both enable signals are de-asserted (low).

Below figure shows the general power scheme for the module, including the power-down sequence.

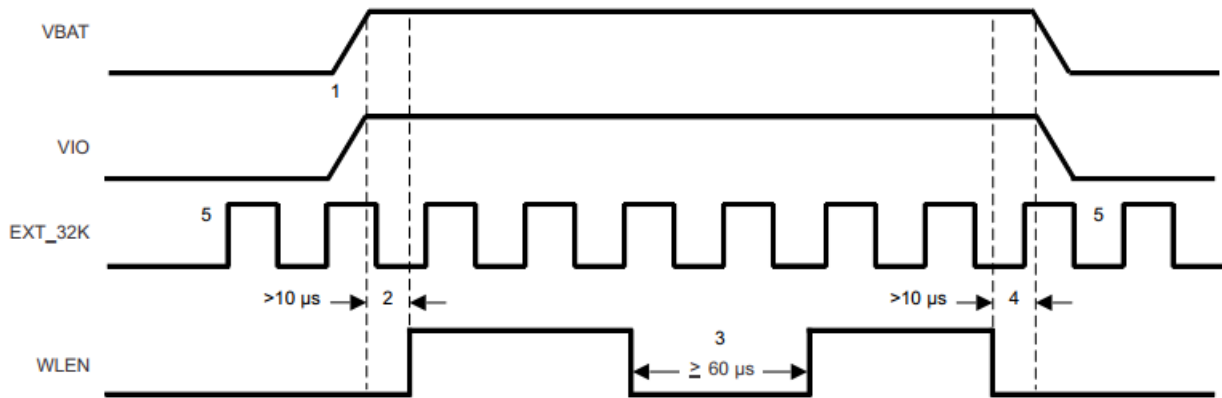

- NOTE: 1. Either VBAT or VIO can come up first.
 2. VBAT and VIO supplies and slow clock (SCLK), must be stable prior to EN being asserted and at all times when the EN is active.
 3. At least 60 IJS is required between two successive device enables. The device is assumed to be in shutdown state during that period, meaning all enables to the device are LOW for that minimum duration.
 4. EN must be de-asserted at least 10 IJS before VBAT or VIO supply can be lowered (order of supply turn off after EN shutdown is immaterial).
 5. EXT_32K- Fail safe I/O

Figure 6-2. Power-Up System

6.3 Chip Top-level Power-Up Sequence

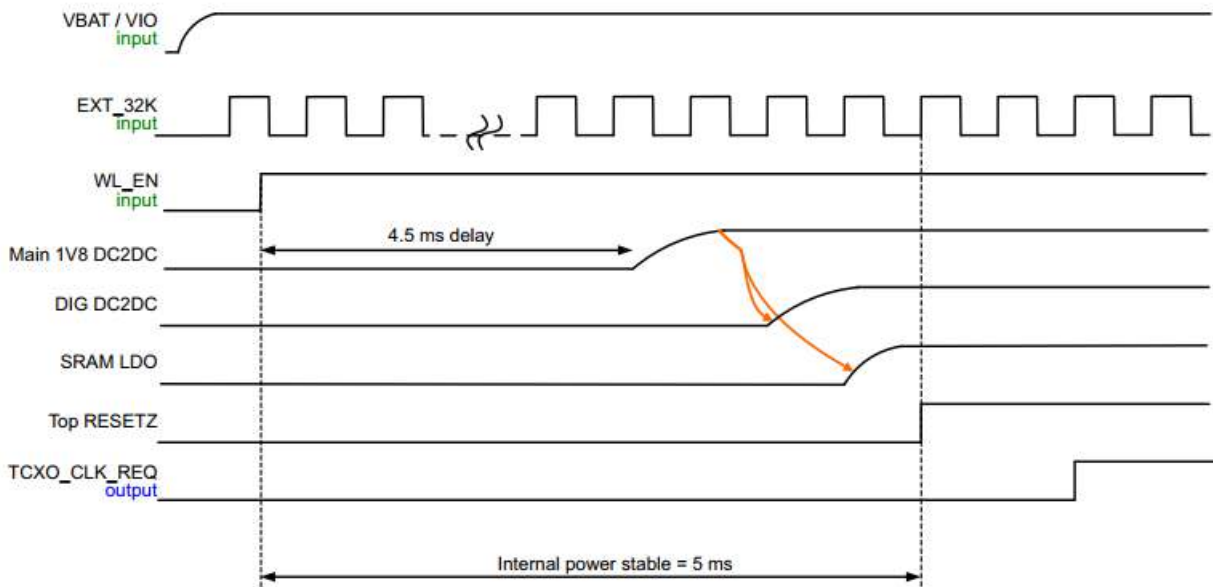

Figure 6-3. Chip Top-Level Power-Up Sequence

6.4 WLAN Power-Up Sequence

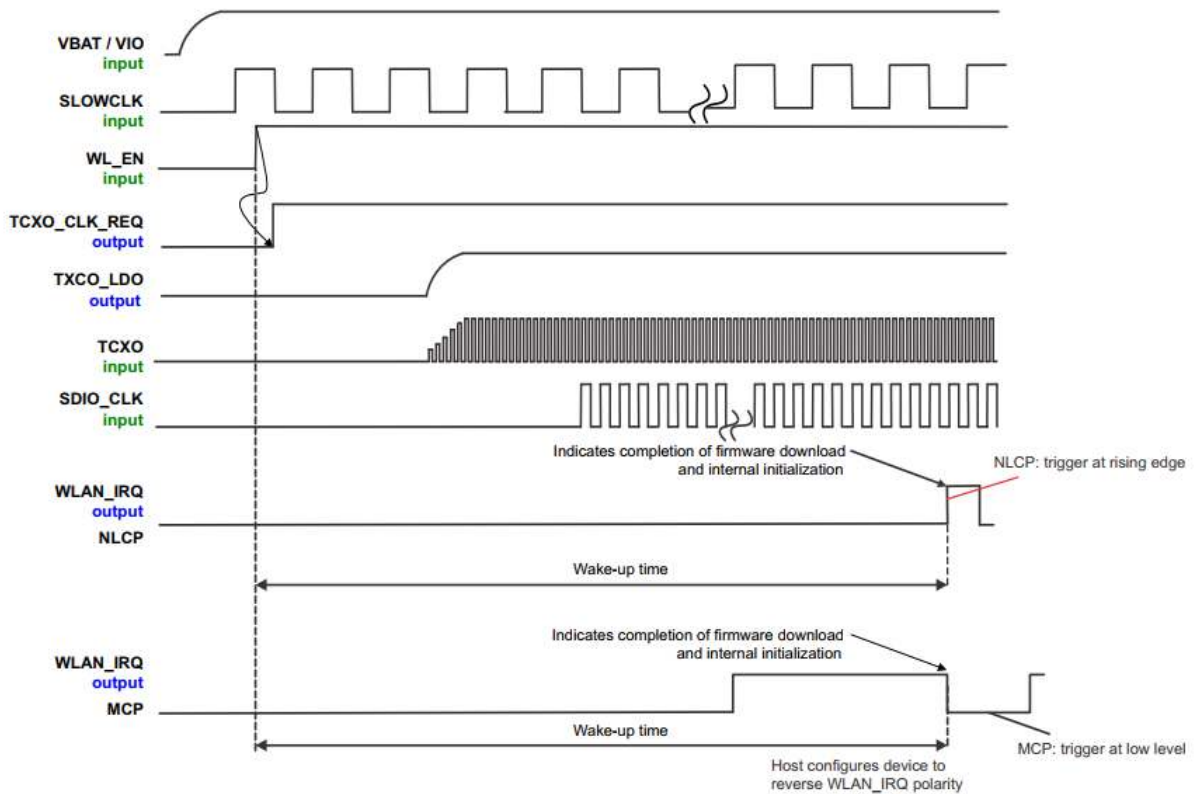

Figure 6-4. WLAN Power-Up Sequence

6.5 Bluetooth-Bluetooth Low Energy Power-Up Sequence

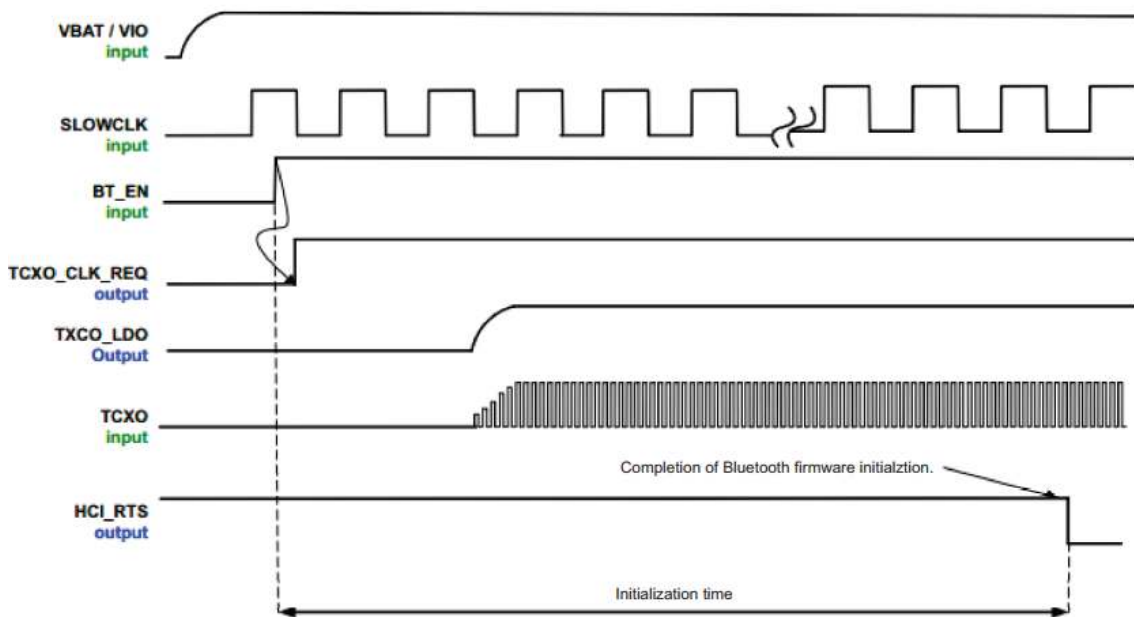

Figure 6-5. Bluetooth-Bluetooth low energy Power-Up Sequence

7. WLAN SDIO Transport Layer

The SDIO is the host interface for WLAN. The interface between the host and the module uses an SDIO interface and supports a maximum clock rate of 50 MHz.

The device SDIO also supports the following features of the SDIO V3 specification:

- 4-bit data bus
- Synchronous and asynchronous in-band interrupt
- Default and high-speed (HS, 50 MHz) timing
- Sleep and wake commands

7.1 SDIO Default Rate Timing Specifications

SDIO switching characteristics over recommended operating conditions and with the default rate.

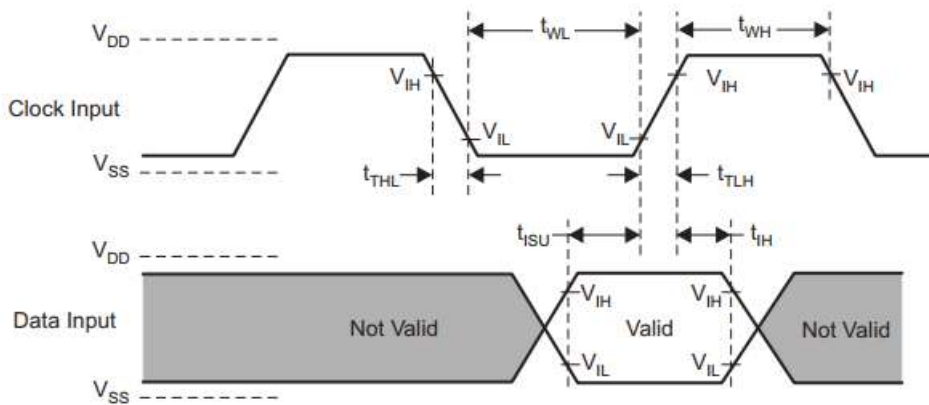

Figure 7-1. SDIO Default Input Timing

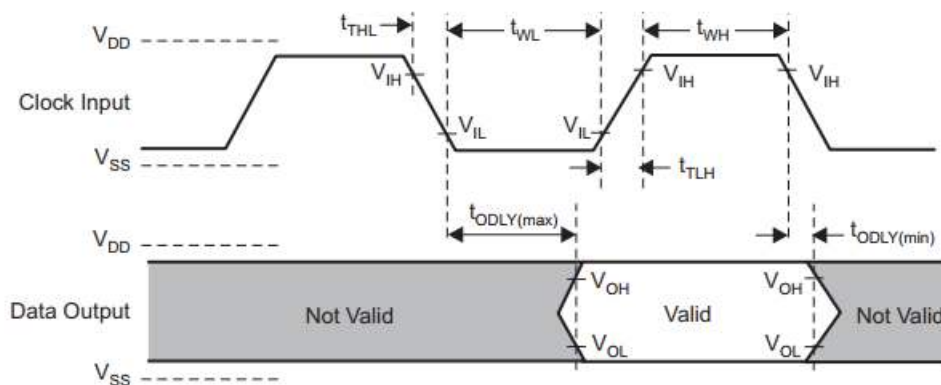

Figure 7-2. SDIO Default Output Timing

Table 7-1 lists the SDIO default timing characteristics.

Table 7-1. SDIO Default Rate Timing Characteristics(1)

		MIN	MAX	UNIT
f_{clock}	Clock frequency, CLK ⁽²⁾	0.0	26.0	MHz
DC	Low, high duty cycle ⁽²⁾	40.0%	60.0%	
t_{TLH}	Rise time, CLK ⁽²⁾		10.0	ns
t_{THL}	Fall time, CLK ⁽²⁾		10.0	ns
t_{ISU}	Setup time, input valid before CLK \uparrow ⁽²⁾	3.0		ns
t_{IH}	Hold time, input valid after CLK \uparrow ⁽²⁾	2.0		ns
t_{ODLY}	Delay time, CLK \downarrow to output valid ⁽²⁾	7.0	10.0	ns
C_1	Capacitive load on outputs ⁽²⁾		15.0	pF

- (1) To change the data out clock edge from the falling edge (default) to the rising edge, set the configuration bit.
- (2) Parameter values reflect maximum clock frequency.

7.2 SDIO HS Switching Characteristics

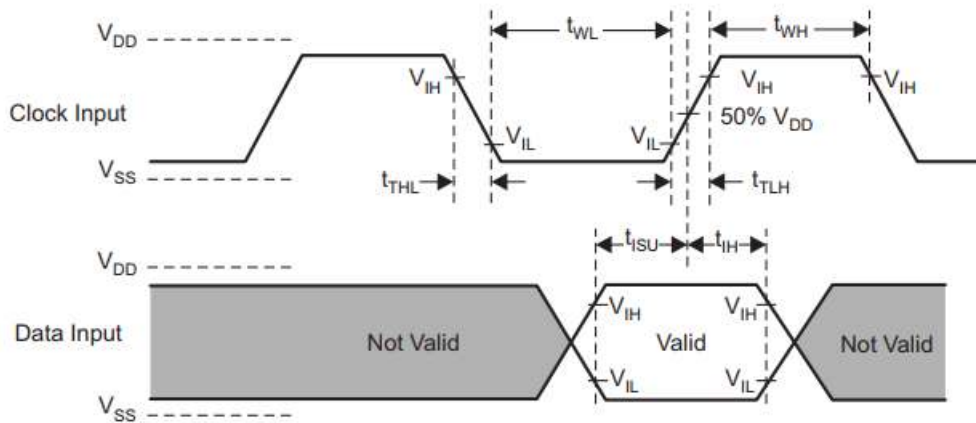

Figure 7-3. SDIO HS Input Timing

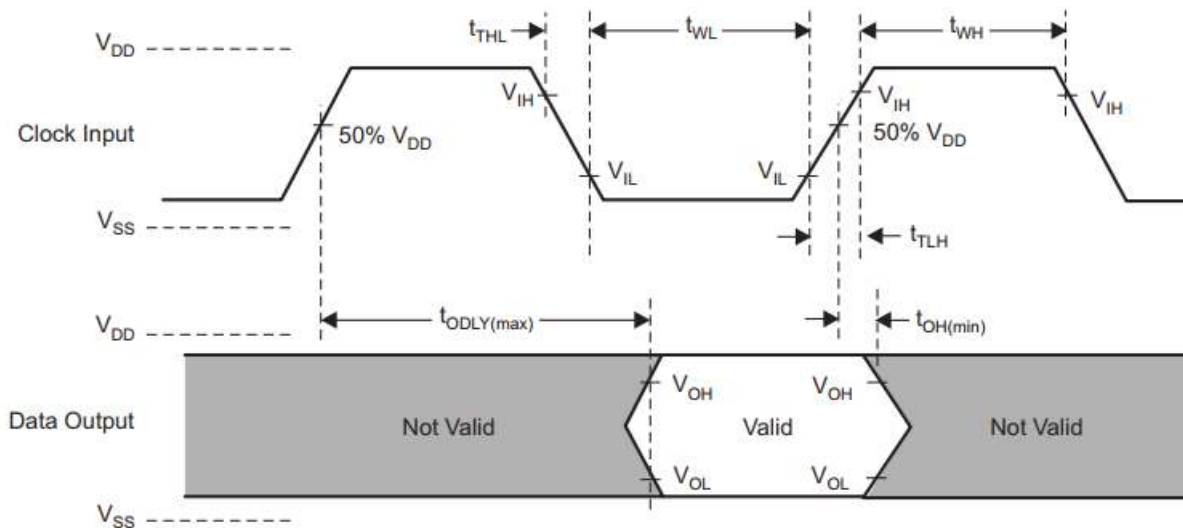

Figure 7-4. SDIO HS Output Timing

Table 7-2 lists the SDIO high-rate timing characteristics.

Table 7-2. SDIO HS Timing Characteristics

		MIN	MAX	UNIT
f_{clock}	Clock frequency, CLK	0.0	52.0	MHz
DC	Low, high duty cycle	40.0%	60.0%	
t_{TLH}	Rise time, CLK		3.0	ns
t_{THL}	Fall time, CLK		3.0	ns
t_{ISU}	Setup time, input valid before CLK \uparrow	3.0		ns
t_{IH}	Hold time, input valid after CLK \uparrow	2.0		ns
t_{ODLY}	Delay time, CLK \downarrow to output valid	7.0	10.0	ns
C_1	Capacitive load on outputs		10.0	pF

8. HCI UART Shared-Transport Layers for All Functional Blocks (Except WLAN)

The device includes a UART module dedicated to the Bluetooth shared-transport, host controller interface (HCI) transport layer. The HCI transports commands, events, and ACL between the Bluetooth device and its host using HCI data packets ack as a shared transport for all functional blocks except WLAN. Below Table lists the transport mechanism for WLAN and Bluetooth audio.

Table 8-1. Transport Mechanism

WLAN	SHARED HCI FOR ALL FUNCTIONAL BLOCKS EXCEPT WLAN	BLUETOOTH VOICE-AUDIO
WLAN HS SDIO	Over UART	Bluetooth PCM

The HCI UART supports most baud rates (including all PC rates) for all fast-clock frequencies up to a maximum of 4 Mbps. After power up, the baud rate is set for 115.2 Kbps, regardless of the fast-clock frequency. The baud rate can then be changed using a VS command. The device responds with a Command Complete Event (still at 115.2 Kbps), after which the baud rate change occurs.

HCI hardware includes the following features:

- Receiver detection of break, idle, framing, FIFO overflow, and parity error conditions
- Receiver-transmitter underflow detection
- CTS, RTS hardware flow control
- 4 wire (H4)

Table 8-2. UART Default Setting

PARAMETER	VALUE
Bit rate	115.2 Kbps
Data length	8 bits
Stop-bit	1
Parity	None

UART 4-Wire Interface – H4

The interface includes four signals:

- TXD
- RXD
- CTS
- RTS

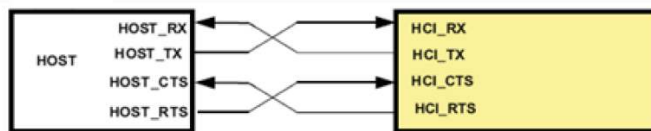

Flow control between the host and the device is byte-wise by hardware.

When the UART RX buffer of the device passes the flow-control threshold, the buffer sets the UART_RTS signal high to stop transmission from the host. When the UART_CTS signal is set high, the device stops transmitting on the interface. If HCI_CTS is set high in the middle of transmitting a byte, the device finishes transmitting the byte and stops the transmission.

Figure 8-1 shows the UART timing.

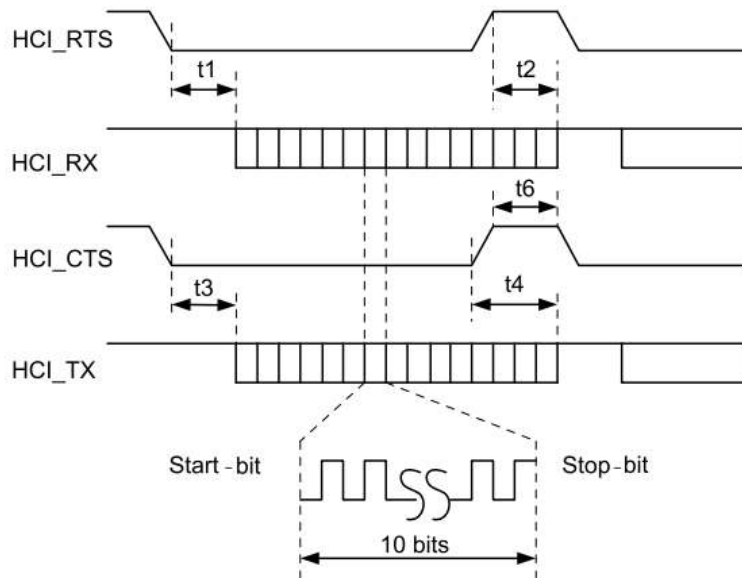

Figure 8-1. UART Timing Diagram

Table 8-3. UART Timing Characteristics

PARAMETER		CONDITION	MIN	TYP	MAX	UNIT
	Baud rate		37.5		4364	Kbps
	Baud rate accuracy per byte	Receive-transmit	-2.5%		1.5%	
	Baud rate accuracy per bit	Receive-transmit	-12.5%		12.5%	
t3	CTS low to TX_DATA on		0.0	2.0		μs
t4	CTS high to TX_DATA off	Hardware flow control			1.0	Byte
t6	CTS high pulse width		1.0			Bit
t1	RTS low to RX_DATA on		0.0	2.0		μs
t2	RTS high to RX_DATA off	Interrupt set to 1/4 FIFO			16.0	Bytes

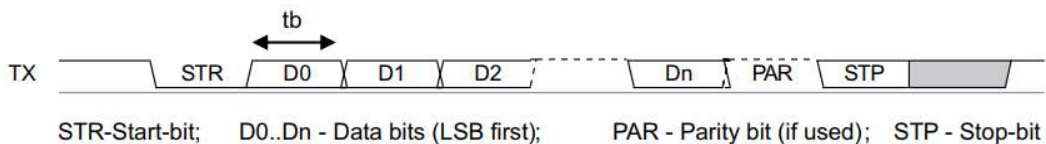

Figure 8-2. UART Data Frame

9. Bluetooth Codec-PCM (Audio) Timing Specifications

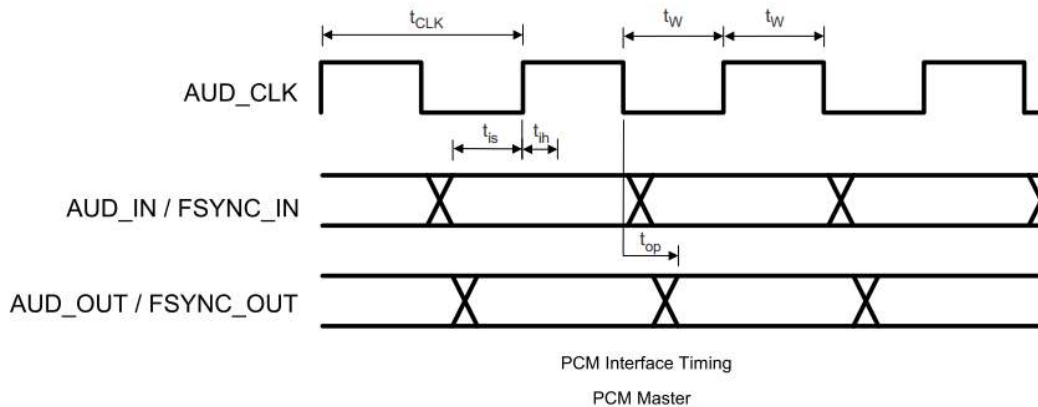

Figure 9-1. Bluetooth Codec-PCM (Audio) Master Timing Diagram

Table 9-1. Bluetooth Codec-PCM Master Timing Characteristics

PARAMETER		MIN	MAX	UNIT
T_{clk}	Cycle time	162.76 (6.144 MHz)	15625 (64 kHz)	ns
T_w	High or low pulse width	35% of T_{clk} min		
t_{is}	AUD_IN setup time	10.6		
t_{ih}	AUD_IN hold time	0		
t_{op}	AUD_OUT propagation time	0	15	
t_{op}	FSYNC_OUT propagation time	0	15	
C_l	Capacitive loading on outputs		40	pF

Table 9-2. Bluetooth Codec-PCM Slave Timing Characteristics

PARAMETER		MIN	MAX	UNIT
T_{clk}	Cycle time	81.38 (12.288 MHz)		ns
T_w	High or low pulse width	35% of T_{clk} min		
t_{is}	AUD_IN setup time	5		
t_{ih}	AUD_IN hold time	0		
t_{is}	AUD_FSYNC setup time	5		
t_{ih}	AUD_FSYNC hold time	0		
t_{op}	AUD_OUT propagation time	0	19	
C_l	Capacitive loading on outputs		40	pF

10. Reference Design

10.1 Block Diagram

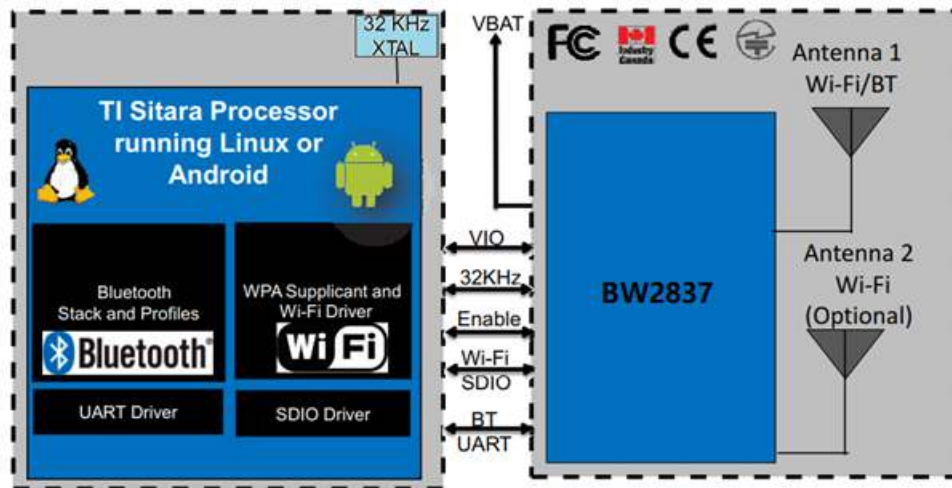

Figure 10-1. BDE-BW2837 High-Level System Diagram

BDE-BW2837

Dual-Band Industrial Module –Wi-Fi, BT, and BLE

10.2 Typical Application Schematic

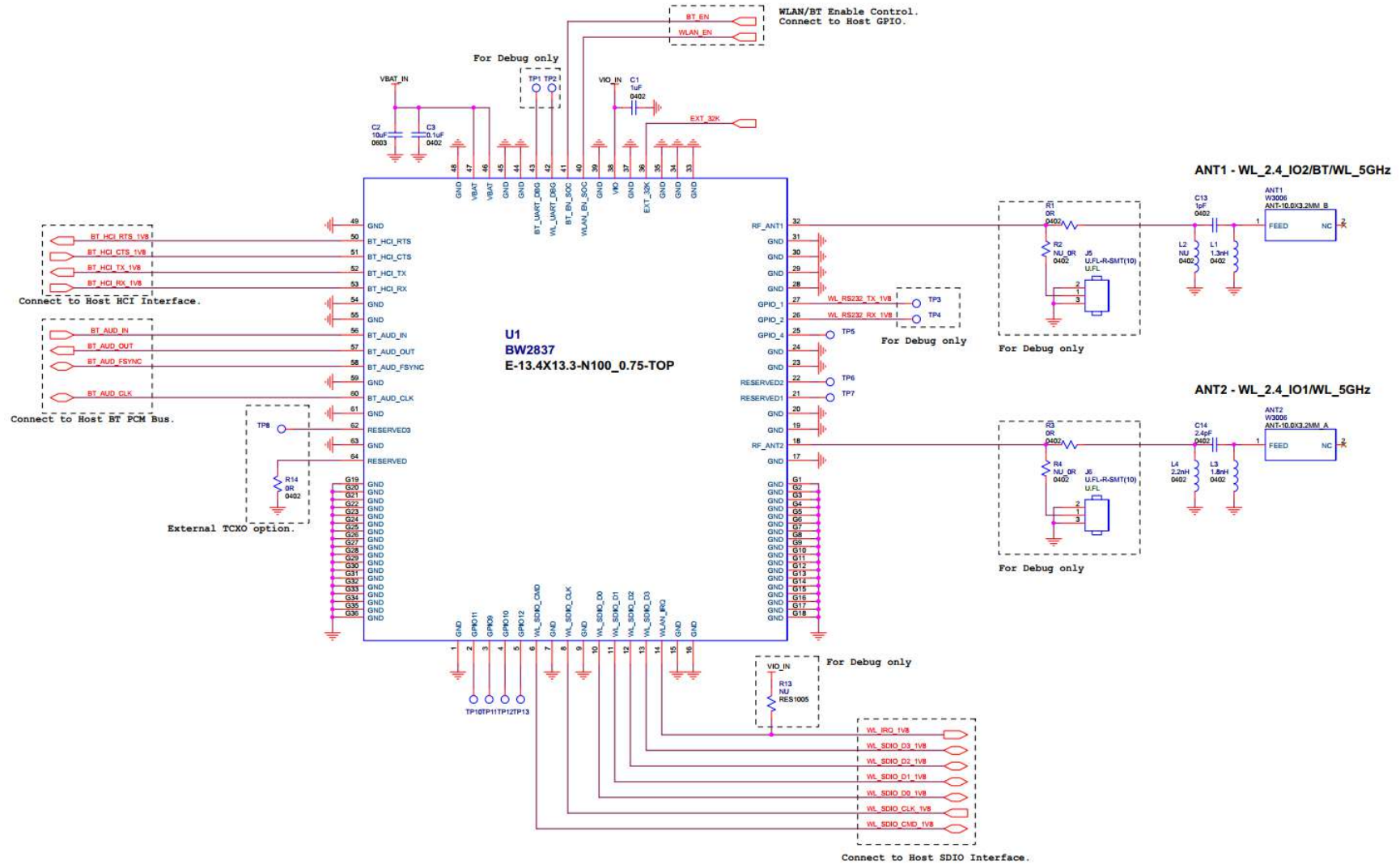

Figure 10-2. BDE-BW2837 Typical Application Schematic

Table 10-1. Bill of Materials

ITEM	DESCRIPTION	PART NO.	PACKAGE	REFERENCE	QTY	MFR
1	BDE-BW2837 Wi-Fi / Bluetooth module	BDE-BW2837	13.4 × 13.3 × 2.0 mm	U1	1	BDE
2	XOSC 3225 / 32.768 kHz / 1.8 V / ±50 ppm	7XZ3200005	3.2 × 2.5 × 1.0 mm	OSC1	1	TXC
3	ANT / Chip / 2.4 GHz and 5 GHz	W3006	10.0 × 3.2 × 1.5 mm	ANT1, ANT2	2	Pulse
4	Mini-RF header receptacle	UFL-R-SMT-1 (10)	3.0 × 2.6 × 1.25 mm	J5, J6	2	Hirose
5	Inductor 0402 / 1.3 nH / ±0.1 nH / SMD	LQP15MN1N3B02	0402	L1	1	Murata
6	Inductor 0402 / 1.8 nH / ±0.1 nH / SMD	LQP15MN1N8B02	0402	L3	1	Murata
7	Inductor 0402 / 2.2 nH / ±0.1 nH / SMD	LQP15MN2N2B02	0402	L4	1	Murata
8	Capacitor 0402 / 1 pF / 50 V / C0G / ±0.1 pF	GJM1555C1H1R0BB01	0402	C13	1	Murata
9	Capacitor 0402 / 2.4 pF / 50 V / C0G / ±0.1 pF	GJM1555C1H2R4BB01	0402	C14	1	Murata
10	Capacitor 0402 / 0.1 μF / 10 V / X7R / ±10%	0402B104K100CT	0402	C3	1	Walsin
11	Capacitor 0402 / 1 μF / 6.3 V / X5R / ±10%/HF	GRM155R60J105KE19D	0402	C1	1	Murata
12	Capacitor 0603 / 10 μF / 6.3 V / X5R / ±20%	C1608X5R0J106M	0603	C2	1	TDK
13	Resistor 0402 / 0R / ±5%	WR04X000 PTL	0402	R1, R3	2	Walsin

10.3 Design Recommendations

Table 10-2. Layout Recommendations Summary

ITEM	DESCRIPTION
Thermal	
1	The proximity of ground vias must be close to the pad.
2	Signal traces must not be run underneath the module on the layer where the module is mounted.
3	Have a complete ground pour in layer 2 for thermal dissipation.
4	Have a solid ground plane and ground vias under the module for stable system and thermal dissipation.
5	Increase the ground pour in the first layer and have all of the traces from the first layer on the inner layers, if possible.
6	Signal traces can be run on a third layer under the solid ground layer, which is below the module mounting layer.
RF Trace and Antenna Routing	
7	The RF trace antenna feed must be as short as possible beyond the ground reference. At this point, the trace starts to radiate.
8	The RF trace bends must be gradual with an approximate maximum bend of 45° with trace mitered. RF traces must not have sharp corners.
9	RF traces must have via stitching on the ground plane beside the RF trace on both sides.
10	RF traces must have constant impedance (microstrip transmission line).
11	For best results, the RF trace ground layer must be the ground layer immediately below the RF trace. The ground layer must be solid.
12	There must be no traces or ground under the antenna section.
13	RF traces must be as short as possible. The antenna, RF traces, and modules must be on the edge of the PCB product. The proximity of the antenna to the enclosure and the enclosure material must also be considered.

ITEM	DESCRIPTION
Supply and Interface	
14	The power trace for VBAT must be at least 40-mil wide.
15	The 1.8-V trace must be at least 18-mil wide.
16	Make VBAT traces as wide as possible to ensure reduced inductance and trace resistance.
17	If possible, shield VBAT traces with ground above, below, and beside the traces.
18	SDIO signals traces (CLK, CMD, D0, 01, 02, and 03) must be routed in parallel to each other and as short as possible (less than 12 em). In addition, every trace length must be the same as the others. There should be enough space between traces- greater than 1.5 times the trace width or ground- to ensure signal quality, especially for the SDIO_CLK trace. Remember to keep these traces away from the other digital or analog signal traces. TI recommends adding ground shielding around these buses.
19	SDIO and digital clock signals are a source of noise. Keep the traces of these signals as short as possible. If possible, maintain a clearance around them.

Figure 10-3 shows the MIMO antenna spacing. The distance between ANT1 and ANT2 must be greater than half the wavelength (62.5 mm at 2.4 GHz).

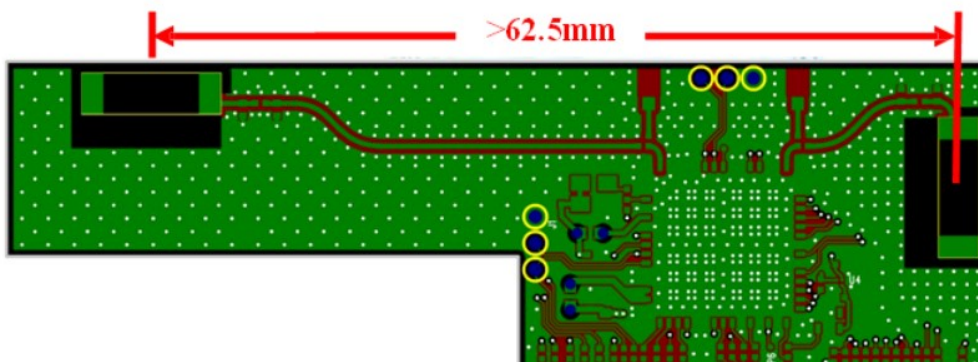

Figure 10-3. MIMO Antenna Spacing

11. Baking and SMT Recommendations

11.1 Baking Recommendations

- Follow MSL level 3 to perform the baking process.
- After the bag is open, devices subjected to reflow solder or other high temperature processes must be mounted within 72 hours of factory conditions (< 30°C/60% RH) or stored at <10% RH.
- If the Humidity Indicator Card reads >10%, devices require baking before they are mounted.
- If baking is required, bake devices for 8 hours at 125°C.

11.2 SMT Recommendations

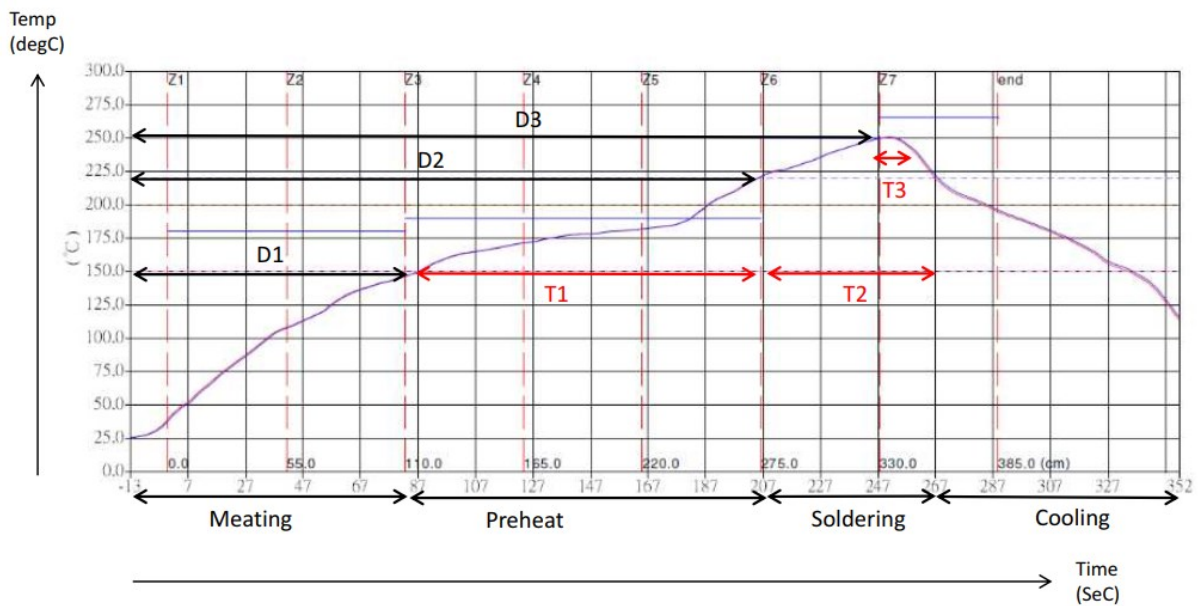

Figure 11-1. Reflow Profile for the WiLink 8 Module

Table 11-1. Temperature Values for Reflow Profile

Item	Temperature (°C)	Time (sec)
Pre - heat	D1 to approximately D2: 140 to 200	T1: 80 to approximately 120
Soldering	D2: 220	T2: 60 ± 10
Peak - Temp.	D3: 250 maximum	T3: 10

12. Mechanical Specifications

12.1 Dimensions

The module dimensions are presented in the following figure:

Note: All dimensions are in mm.

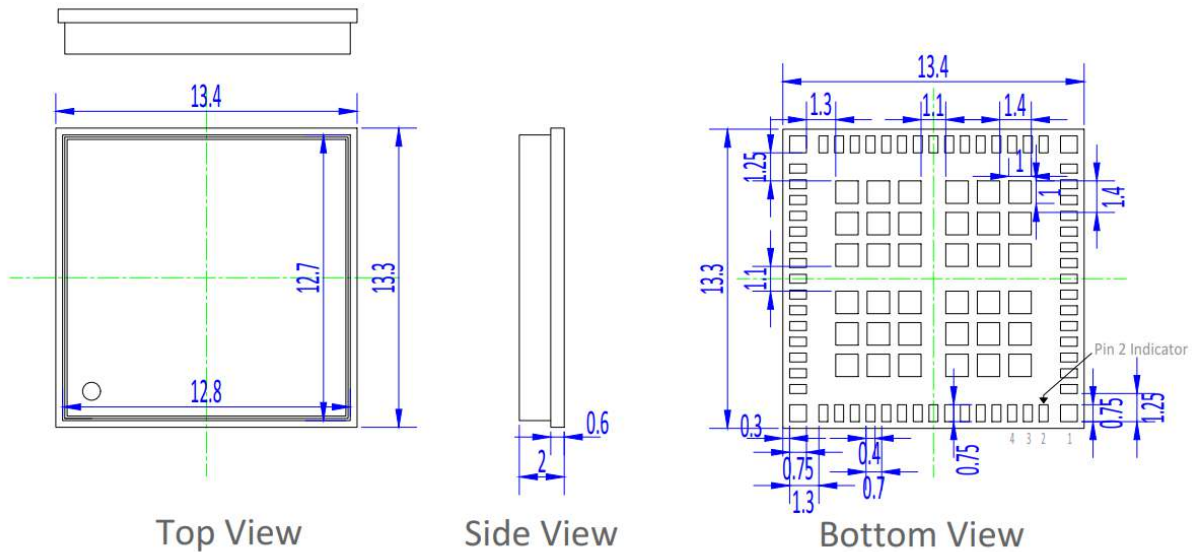

Notes:
 All dimensions are in mm
 Coplanarity applies to the exposed pads as well as the terminals
 Coplanarity shall not exceed 0.1 mm
 Warpage shall not exceed 0.1 mm

Figure 12-1. Mechanical Drawing

12.2 PCB Footprint

The footprint for the PCB is presented in the following figure:

Note: All dimensions are in mm.

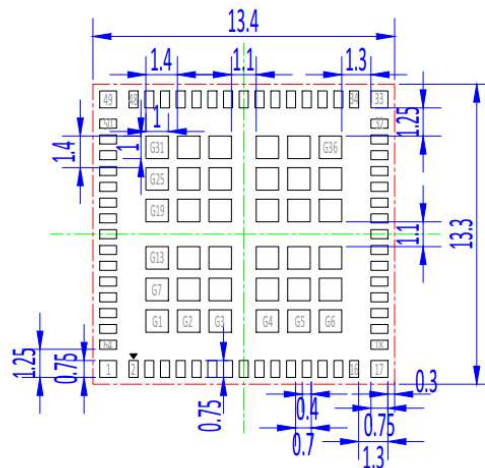

Figure 12-2. Module Footprint Top View

12.3 Marking

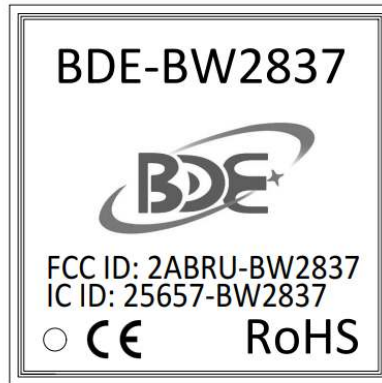

Figure 12-3. Indicative Module Shield Marking

13. Packaging Information

Tape and Reel Information

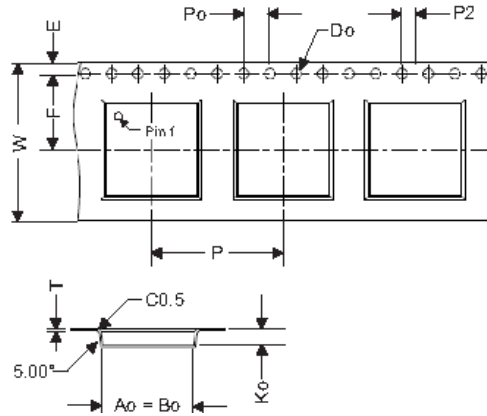

Figure 13-1. Tape Specification

Table 13-1. Dimensions for Tape Specification

ITEM	w	E	F	p	Po	P2	Do	T	Ao	Bo	Ko
DIMENSION (mm)	24.00 (±0.30)	1.75 (±0.10)	11.50 (±0.10)	20.00 (±0.10)	4.00 (±0.10)	2.00 (±0.10)	2.00 (±0.10)	0.35 (±0.05)	13.80 (±0.10)	13.80 (±0.10)	2.50 (±0.10)

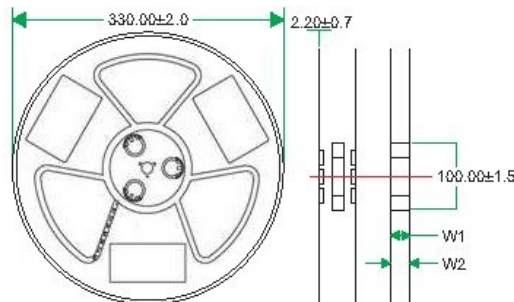

Figure 13-2. Reel Specification

Table 13-2. Dimensions for Reel Specification

ITEM	W1	W2
DIMENSION (mm)	244 (+1.5, -0.5)	304 (maximum)

14. Ordering Information

Part Number	Size (mm)	Core Chip	Package	MOQ
BDE-BW2837	13.3 × 13.4 × 2	WL1837	Tape & Reel	1000

15. Revision History

Revision	Date	Description
V0.9	7-Sept-2020	Initial Draft
V1.0	5-Oct-2020	Editorial Correction
V2.0	12-Apr-2021	Replacement of template

Contacts

BDE Technology Inc.

China: B2-403, 162 Science Avenue, Huangpu District, Guangzhou 510663, China

Tel: +86-20-28065335

Website: <http://www.bdecomm.com>

Email: shu@bdecomm.com

USA: 67 E Madison St, #1603A, Chicago, IL 60603, US

Tel: +1-312-379-9589

Website: <http://www.bdecomm.com>

Email: info@bdecomm.com