

TZV series

105°C 2000時間 低インピーダンス品
Load life : 105°C 2000 hours, Low Impedance

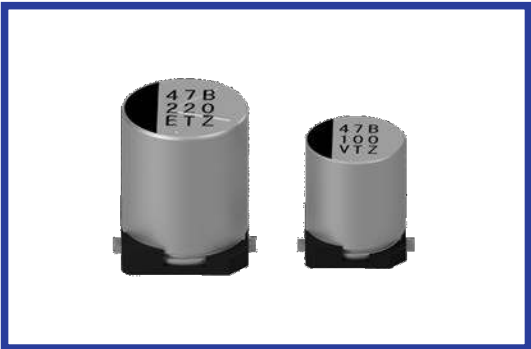

AEC-Q200



◆規格表 / SPECIFICATIONS

項目 Item	特性 Characteristics																																
カテゴリ温度範囲 Category Temperature Range	-55~+105°C																																
定格電圧範囲 Rated Voltage Range	6.3~50Vdc																																
静電容量許容差 Capacitance Tolerance	±20%(20°C, 120Hz)																																
漏れ電流 Leakage Current (MAX)	I=0.01CV又は3μAのいずれか大なる値以下(定格電圧印加2分後) I=0.01CV or 3 μA whichever is greater. (After 2 minutes) I=漏れ電流(μA) C=静電容量(μF) V=定格電圧(Vdc) Leakage Current Capacitance Rated Voltage																																
損失角の正接(tan δ) Dissipation Factor(MAX)	<table border="1"> <tr> <td>定格電圧 (Vdc) Rated Voltage</td> <td>6.3</td> <td>10</td> <td>16</td> <td>25</td> <td>35</td> <td>50</td> <td>(20°C, 120Hz)</td> </tr> <tr> <td>tan δ</td> <td>0.26</td> <td>0.19</td> <td>0.16</td> <td>0.14</td> <td>0.12</td> <td>0.10</td> <td></td> </tr> </table>	定格電圧 (Vdc) Rated Voltage	6.3	10	16	25	35	50	(20°C, 120Hz)	tan δ	0.26	0.19	0.16	0.14	0.12	0.10																	
定格電圧 (Vdc) Rated Voltage	6.3	10	16	25	35	50	(20°C, 120Hz)																										
tan δ	0.26	0.19	0.16	0.14	0.12	0.10																											
耐久性 Endurance	105°C中で2000時間定格電圧(リップル重畳)印加後、下記項目を満足すること。 After applying rated voltage with rated ripple current for 2000 hours at 105°C, the capacitors shall meet the following requirements. <table border="1"> <tr> <td>静電容量変化率 Capacitance Change</td> <td>初期値の ±30% 以内 Within ±30% of the initial value.</td> </tr> <tr> <td>損失角の正接 Dissipation Factor</td> <td>規格値の 200% 以下 Not more than 200% of the specified value.</td> </tr> <tr> <td>漏れ電流 Leakage Current</td> <td>規格値以下 Not more than the specified value.</td> </tr> </table>	静電容量変化率 Capacitance Change	初期値の ±30% 以内 Within ±30% of the initial value.	損失角の正接 Dissipation Factor	規格値の 200% 以下 Not more than 200% of the specified value.	漏れ電流 Leakage Current	規格値以下 Not more than the specified value.																										
静電容量変化率 Capacitance Change	初期値の ±30% 以内 Within ±30% of the initial value.																																
損失角の正接 Dissipation Factor	規格値の 200% 以下 Not more than 200% of the specified value.																																
漏れ電流 Leakage Current	規格値以下 Not more than the specified value.																																
低温特性 Low Temperature Stability (インピーダンス比) Impedance Ratio (MAX)	<table border="1"> <tr> <td>定格電圧 (Vdc) Rated Voltage</td> <td>6.3</td> <td>10</td> <td>16</td> <td>25</td> <td>35</td> <td>50</td> <td>(120Hz)</td> </tr> <tr> <td>Z(-25°C)/Z(20°C)</td> <td>2</td> <td>2</td> <td>2</td> <td>2</td> <td>2</td> <td>2</td> <td></td> </tr> <tr> <td>Z(-40°C)/Z(20°C)</td> <td>3</td> <td>3</td> <td>3</td> <td>3</td> <td>3</td> <td>3</td> <td></td> </tr> <tr> <td>Z(-55°C)/Z(20°C)</td> <td>4</td> <td>4</td> <td>4</td> <td>3</td> <td>3</td> <td>3</td> <td></td> </tr> </table>	定格電圧 (Vdc) Rated Voltage	6.3	10	16	25	35	50	(120Hz)	Z(-25°C)/Z(20°C)	2	2	2	2	2	2		Z(-40°C)/Z(20°C)	3	3	3	3	3	3		Z(-55°C)/Z(20°C)	4	4	4	3	3	3	
定格電圧 (Vdc) Rated Voltage	6.3	10	16	25	35	50	(120Hz)																										
Z(-25°C)/Z(20°C)	2	2	2	2	2	2																											
Z(-40°C)/Z(20°C)	3	3	3	3	3	3																											
Z(-55°C)/Z(20°C)	4	4	4	3	3	3																											

◆呼称方法 / PART NUMBER

□□□	TZV	□□□□□	M	□□□	D x L
定格電圧 Rated Voltage	シリーズ名 Series	静電容量 Capacitance	静電容量許容差 Capacitance Tolerance	副記号 Option	ケースサイズ Case Size

◆リップル電流補正係数 / MULTIPLIER FOR RIPPLE CURRENT

周波数 (Hz) Frequency	120	1k	10k	100k ≤
4.7 μF	0.30	0.60	0.80	1.00
10~47 μF	0.32	0.75	0.90	1.00
100 μF	0.50	0.80	0.95	1.00
220~1000 μF	0.60	0.85	0.95	1.00

◆表示 / MARKING

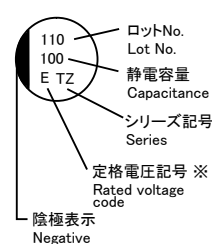

※電圧記号 Voltage code

定格電圧 (Vdc) Rated Voltage	6.3	10	16	25	35	50
電圧記号 Voltage code	j	A	C	E	V	H

◆寸法図／DIMENSIONS

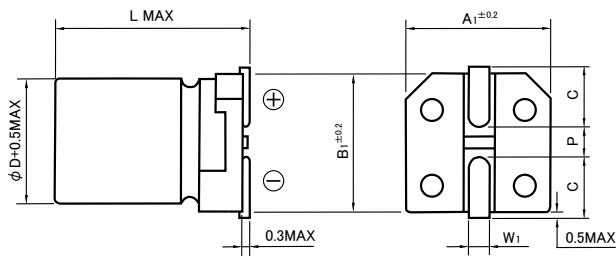

φD	L	A1	B1	C	W1	P
4	6.1	4.3	4.3	1.8	0.5~0.8	1.0
5	6.1	5.3	5.3	2.2	0.5~0.8	1.3
6.3	6.1	6.6	6.6	2.7	0.5~0.8	1.8
6.3	8	6.6	6.6	2.7	0.5~0.8	1.8
8	10.5	8.3	8.3	2.9	0.8~1.1	3.1
10	10.5	10.3	10.3	3.2	0.8~1.1	4.5

◆標準品一覧表／STANDARD SIZE

Size φD×L(mm), Rated Ripple Current (mA r.m.s./105°C, 100kHz), Impedance(Ω MAX/20°C, 100kHz)

Vdc	Cap (μF)	Size (φD×L)	Ripple	Impedance
6.3	22	4×6.1	90	1.35
	47	4×6.1	90	1.35
		5×6.1	170	0.70
	100	5×6.1	170	0.70
		6.3×6.1	250	0.36
	220	6.3×6.1	250	0.36
		6.3×8	300	0.34
	330	6.3×8	300	0.34
1000	8×10.5	600	0.16	
10	33	4×6.1	90	1.35
	220	6.3×8	300	0.34
	470	8×10.5	600	0.16
	680	8×10.5	600	0.16
	1000	10×10.5	850	0.08
16	10	4×6.1	90	1.35
	22	4×6.1	90	1.35
		5×6.1	170	0.70
	33	5×6.1	170	0.70
	47	5×6.1	170	0.70
		6.3×6.1	250	0.36
	100	6.3×6.1	250	0.36
		6.3×8	300	0.34
	220	6.3×8	300	0.34
	330	8×10.5	600	0.16
470	8×10.5	600	0.16	
680	10×10.5	850	0.08	

Vdc	Cap (μF)	Size (φD×L)	Ripple	Impedance
25	33	5×6.1	170	0.70
		6.3×6.1	250	0.36
	47	6.3×6.1	250	0.36
	100	6.3×8	300	0.34
	220	8×10.5	600	0.16
	330	8×10.5	600	0.16
	470	10×10.5	850	0.09
	35	4.7	4×6.1	90
10		4×6.1	90	1.45
		5×6.1	170	0.70
22		5×6.1	170	0.70
		6.3×6.1	250	0.36
33		6.3×6.1	250	0.36
47		6.3×6.1	250	0.36
		6.3×8	300	0.34
100		6.3×8	300	0.34
		8×10.5	600	0.16
220	8×10.5	600	0.16	
330	10×10.5	850	0.09	
50	4.7	4×6.1	60	2.90
	10	5×6.1	85	1.52
		6.3×6.1	165	0.88
	22	6.3×6.1	165	0.88
	33	6.3×8	195	0.68
	47	6.3×8	195	0.68
	100	8×10.5	350	0.34
	220	10×10.5	670	0.18