

Intel® MD882X ADSL G.Lite and V.90 Modem Chipset

Overview

The Intel® MD882X modem chipset delivers simultaneous G.Lite and V.90 operation. Dual functionality gives the user the ability to fully utilize their ADSL G.Lite connection while concurrently sending or receiving V.90 data, fax, or voice over a POTS line. Modems designed with the MD882X are easy for users to install—no truck roll required.

Based on Intel's Host Accelerated Modem technology (HaM), the MD882X delivers added savings by eliminating the controller chip. It uses a portion of the host's processor power to implement G.Lite and V.90 operation.

The MD882X G.Lite chipset is ITU G.992.2 compliant and uses discrete multitone encoding (DMT). It is capable of data transfer rates of up to 1.536 Mbits/second downstream, and 512 Kbits/second upstream depending on line conditions and distance from the central office.

This chipset consists of an accelerator/PCI chip and two Sigma Delta Analog Front End (SAFE) chips—one for ADSL and the other for V.90 operation. An optional AFE is available to

provide full-duplex speakerphone capability. The MD882X also offers future software upgradability for T1.413 compatibility, and support for G.992.2 Annex B and C, and G.992.1 Annex A, B, and C.

The MD882X includes a PCI (Rev 2.2) interface and runs on Pentium® III processor (500MHz and above) or equivalent. It is compatible with Windows® 98, ME, and 2000, and supports legacy modems and fax standards to insure interoperability with existing modems.

Intel has carried out extensive DSLAM interoperability testing, and will continue to do so. Entire end-to-end testing has also been conducted using the LAN encapsulation mode.

The Intel MD882X G.Lite chipset is a high-performance, cost effective PCI solution that delivers concurrent G.Lite and V.90 operation.

System Block Diagram

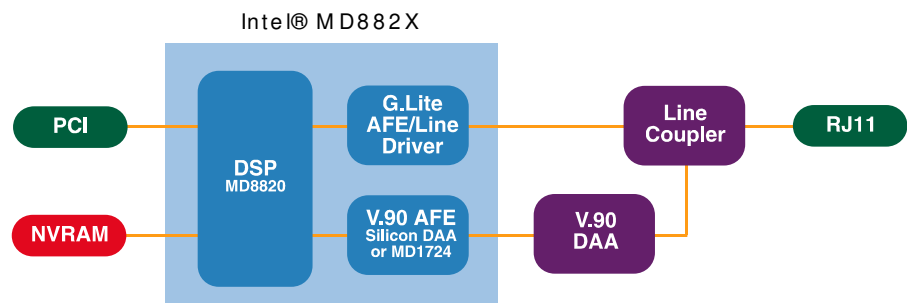

Features: MD882X

- MD882X chipset
 - Digital Signal Processor
 - ADSL SAFE and Line Driver
 - V.90 SAFE
- Concurrent G.Lite and V.90 operation
- PCI Rev 2.2 and ACPI compliant
- Supports Windows* 98, ME and 2000
- Pentium® III processor (500MHz and above, or similar)
- High integration solution
- Microsoft*, Windows TAPI compliant

ADSL

- ITU G.Lite (G.992.2) compliant
- Discrete Multitone (DMT) based encoding
- Annex A
- Up to 1.536 Mbits/sec. downstream
- Up to 512 Kbits/sec. upstream
- Splitterless operation
- Network interface via full ATM protocol stack
- Error correction using FEC (Reed Solomon) scheme
- Future software upgradability for T1.413 compatibility, and support for
 - G.992.2 Annex B and C
 - G.992.1 Annex A, B, and C

V.90 and Legacy

- ITU V.90 56K compliant
- ITU V.34 (33,600 to 2400bps) symmetrical and asymmetrical operation
- ITU V.32bis, V.23, V.22bis, V.21
- Bell* 212A and 103
- ITU V.17, V.29, and V.27 Fax modes (2400 to 14,400bps)
- Voice compression: ADPCM, linear, and CL1
- Voice sampling rates 4800, 7200, 8000, 9600, and 11025 samples per second
- IS-101 voice commands
- Fax Class 1
- Full-duplex digital speakerphone with echo-cancelling (optional)
- Error correction: ITU-V.42 and MNP* 2-4
- Data compression: ITU-V.42bis and MNP 5
- CTR-21 compliant
- Future software upgradeable to V.92/V.44

Product

MD8820 Digital Signal Processor (DSP)
MD1724 Sigma Delta Analog Front End (SAFE)
G.Lite AFE

Package

128-pin SQFP
44-pin LQFP, or Silicon DAA 16-pin SOIC (2)
64-pin HTQFP

Intel Access

World Wide Web	www.intel.com
Developer site	www.developer.intel.com
Intel, Modem Silicon Operations	
USA - California	(510) 683-6600
USA - North Carolina	(919) 870-5060
Germany	(49) 681-99272-0
Taiwan	(886) 2-2794-8855

Intel Corporation assumes no responsibility for the use of any circuitry other than circuitry embodied in an Intel product. No other circuit patent licenses are implied. Information contained herein is subject to change without notice and supersedes previously published specifications on these devices. *Other brands and names are the property of their respective owners. 11-00

For more information, visit the Intel Web site at: www.developer.intel.com



UNITED STATES AND CANADA
Intel Corporation
Robert Noyce Building
2200 Mission College Blvd.
P.O. Box 58119
Santa Clara, CA 95052-8119
USA
(800) 628-8686

EUROPE
Intel Corporation (UK) Ltd.
Pipers Way
Swindon
Wiltshire SN3 1RJ
UK
(44) 1793 403 0000

ASIA-PACIFIC
Intel Semiconductor Ltd.
32/F Two Pacific Place
88 Queensway, Central
Hong Kong, SAR
(852) 2844 4555

JAPAN
Intel Kabushiki Kaisha
P.O. Box 115 Tsukuba-gakuen
5-6 Tokodai, Tsukuba-shi
Ibaraki-ken 305
Japan
(81) 298 47 8522

SOUTH AMERICA
Intel Semicondutores do Brazil
Rue Florida, 1703-2 and CJ22
CEP 04565-001 Sao Paulo-SP
Brazil
(55) 11 5505 2296