

THIS DRAWING IS UNPUBLISHED. RELEASED FOR PUBLICATION
 © COPYRIGHT - By - ALL RIGHTS RESERVED.

LOC		DIST		REVISIONS			
P	LTR	DESCRIPTION	DATE	DWN	APVD		
GP	00	N	REVISED PER ECO-13-013280	21AUG2013	CJV	CWR	

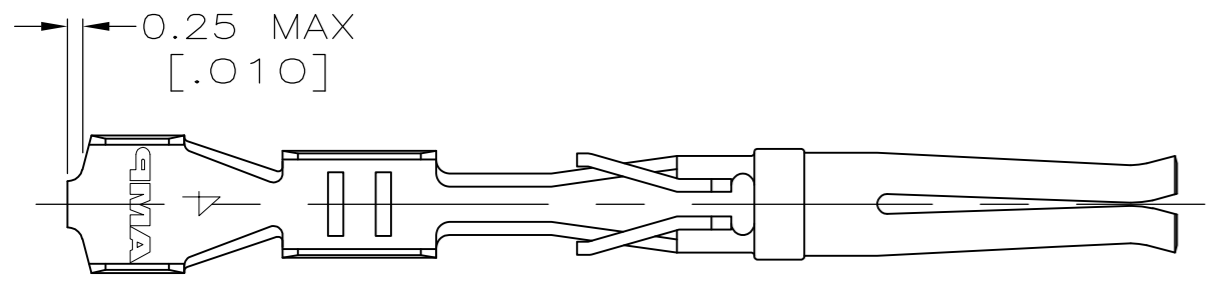

DETAIL Z
SCALE 8:1

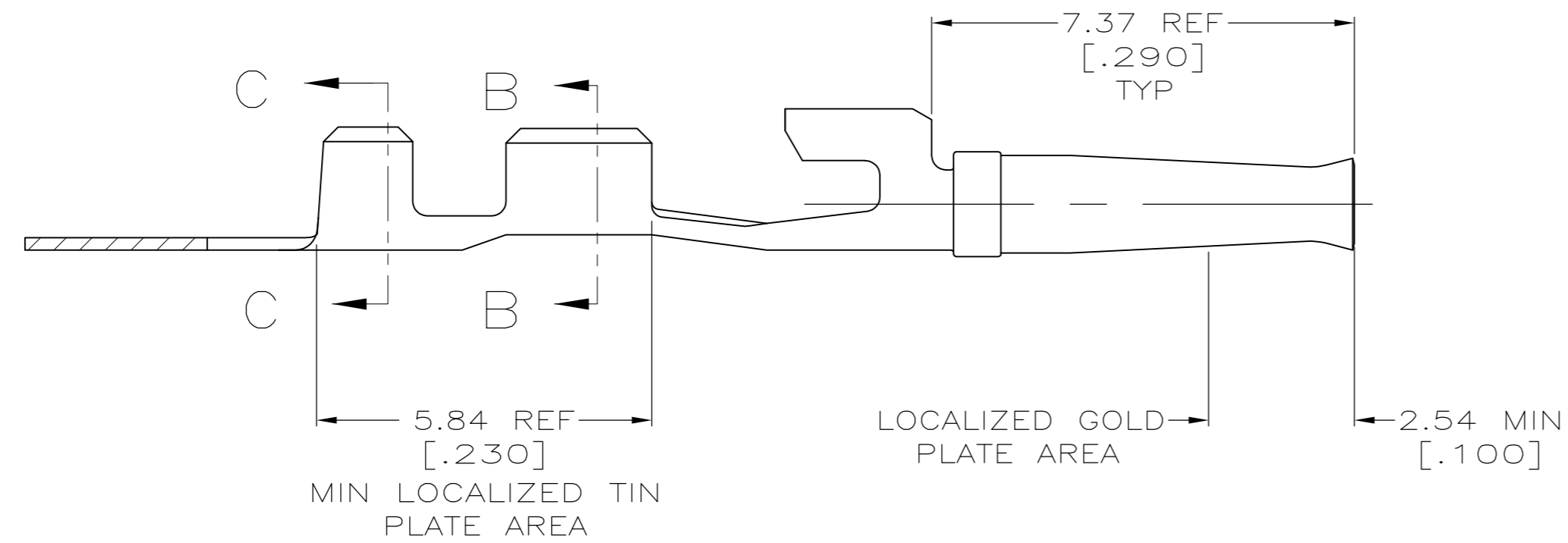
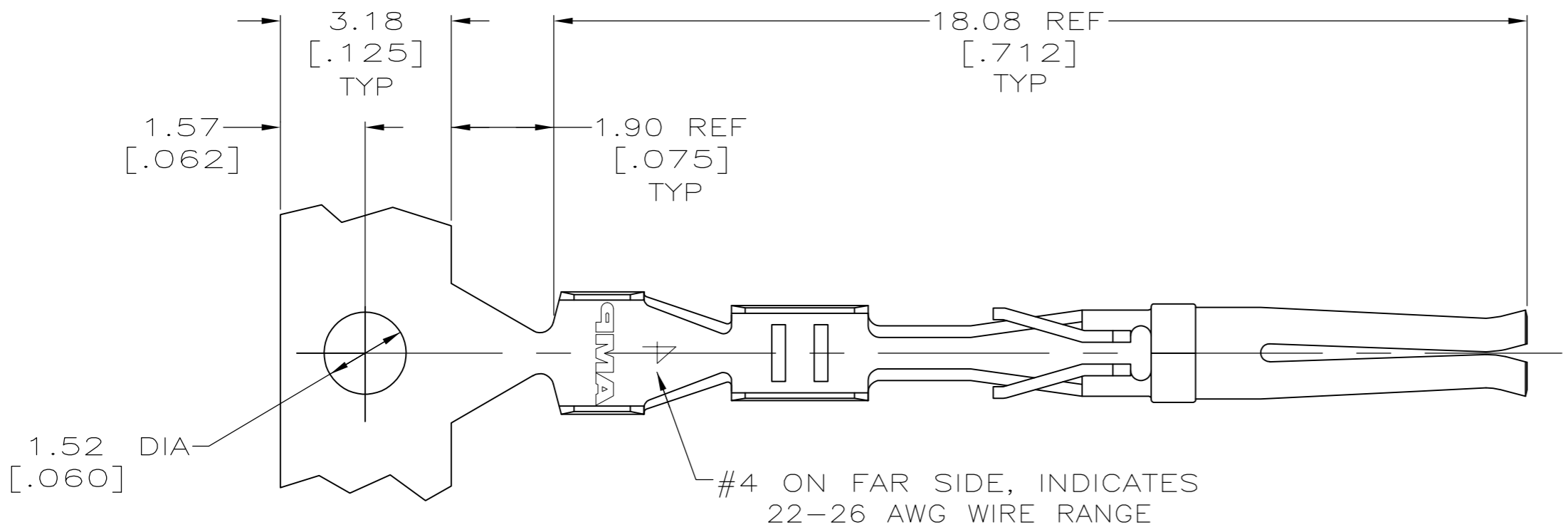

- ① GOLD PLATING PER MIL-G-45204, TIN PLATING PER MIL-T-10727, NICKEL PLATING PER QQ-N-290.
- ② 0.76 μm [.000030] MIN GOLD IN LOCALIZED GOLD PLATE AREA, 2.54 μm [.000100] MIN BRIGHT TIN OR BRIGHT TIN-LEAD IN MIN LOCALIZED TIN PLATE AREA, ALL OVER 0.76 μm [.000030] MIN NICKEL.
- ③ GOLD FLASH IN LOCALIZED GOLD PLATE AREA, 2.54 μm [.000100] MIN BRIGHT TIN OR BRIGHT TIN-LEAD IN MIN LOCALIZED TIN PLATE AREA, ALL OVER 0.76 μm [.000030] MIN NICKEL.
- ④ GOLD FLASH IN LOCALIZED GOLD PLATE AREA, 2.54 μm [.0001] MIN MATTE TIN IN LOCALIZED TIN PLATE AREA, ALL OVER 0.76 μm [.000030] MIN NICKEL UNDERPLATE.
- ⑤ 0.76 μm [.000030] MIN GOLD IN LOCALIZED GOLD PLATE AREA, 2.54 μm [.0001] MIN MATTE TIN IN LOCALIZED TIN PLATE AREA, ALL OVER 1.27 μm [.000050] MIN NICKEL UNDERPLATE.
- ⑥ PHOSPHOR BRONZE PER QQ-B-750.

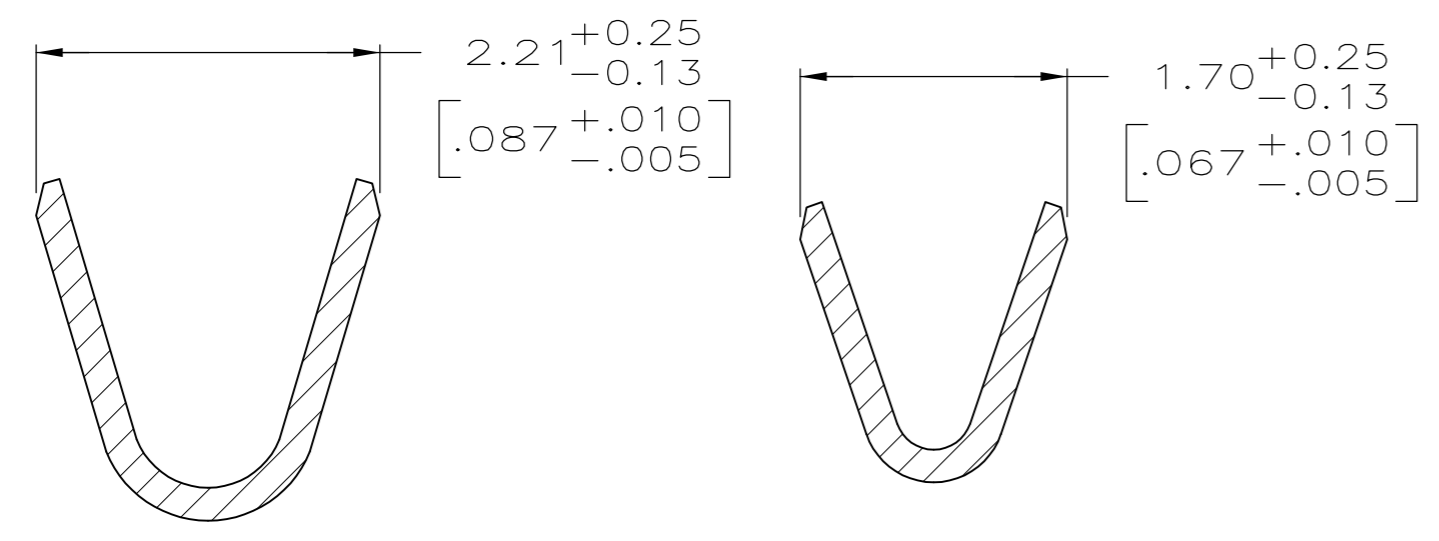
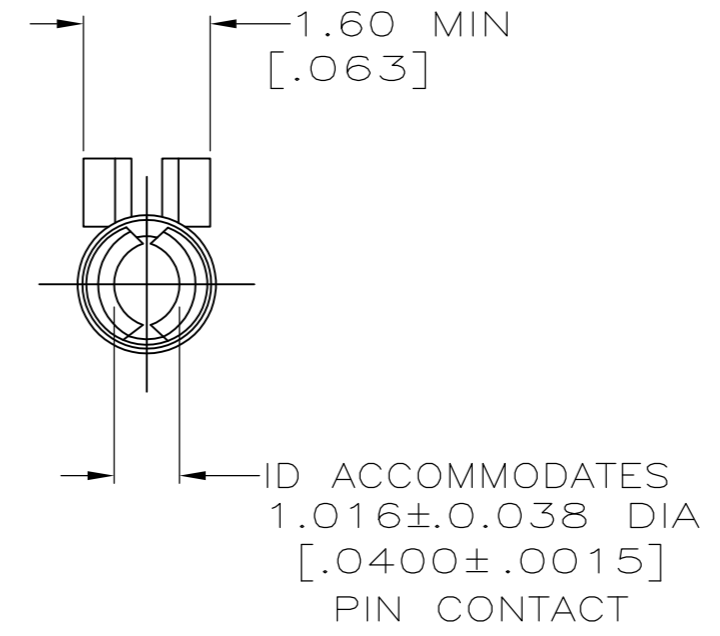

SECTION C-C
SCALE 20:1

SECTION B-B
SCALE 20:1

	⑤	-	1-745269-1
	④	-	1-745269-0
SUPERSEDED BY 745269-3	-	DETAIL Z	745269-9
SUPERSEDED BY 745269-2	-	-	745269-8
	OBSOLETE	③	DETAIL Z
	OBSOLETE	③	-
SUPERSEDED BY 745269-7	-	DETAIL Z	745269-5
SUPERSEDED BY 745269-6	-	-	745269-4
	OBSOLETE	②	DETAIL Z
	OBSOLETE	②	-
	FINISH	LOOSE PIECE	PART NO

THIS DRAWING IS A CONTROLLED DOCUMENT.		DWN L. VARELA - DOCK5 11-15-04	STE TE Connectivity	
		CHK J. GERACE 11-15-04		
DIMENSIONS: mm [INCHES]		APVD M. WALMSLEY 11-15-04	NAME CONTACT SOCKET, OPEN BARREL, #22-26, HDE-20, AMPLIMITE	
TOLERANCES UNLESS OTHERWISE SPECIFIED:		PRODUCT SPEC 108-40011	SIZE CAGE CODE DRAWING NO RESTRICTED TO	
0 PLC ± -		APPLICATION SPEC 114-40003	A2 00779	C=745269
1 PLC ± -		WEIGHT -	SCALE 10:1 SHEET 1 OF 1 REV N	
2 PLC ± 0.13 [.005]		CUSTOMER DRAWING		
3 PLC ± -				
4 PLC ± -				
ANGLES ± -				
MATERIAL ⑥	FINISH ① SEE TABLE			