

REV.	DATE	ECR NO.	DESCRIPTION
NC	07/01/03	XXXXXX	INITIAL RELEASE
A	07/05/03	XXXXXX	UPDATE DRAWING FORMAT
B	07/15/03	XXXXXX	CHANGE INSULATOR TO DELRIN
C	04/01/08	XXXXXX	CHANGE INSULATOR TO PTFE, REVISE CABLE DESCRIPTION
D	05/21/08	XXXXXX	CHANGE INSULATOR TO DELRIN
E	12/02/13	2663	ADD SPACER, ADD TABLE A AND MODIFY STRIPPING DIMENSIONS ADD ELECTRICAL/MECHANICAL NOTES, UPDATE DRAWING FORMAT

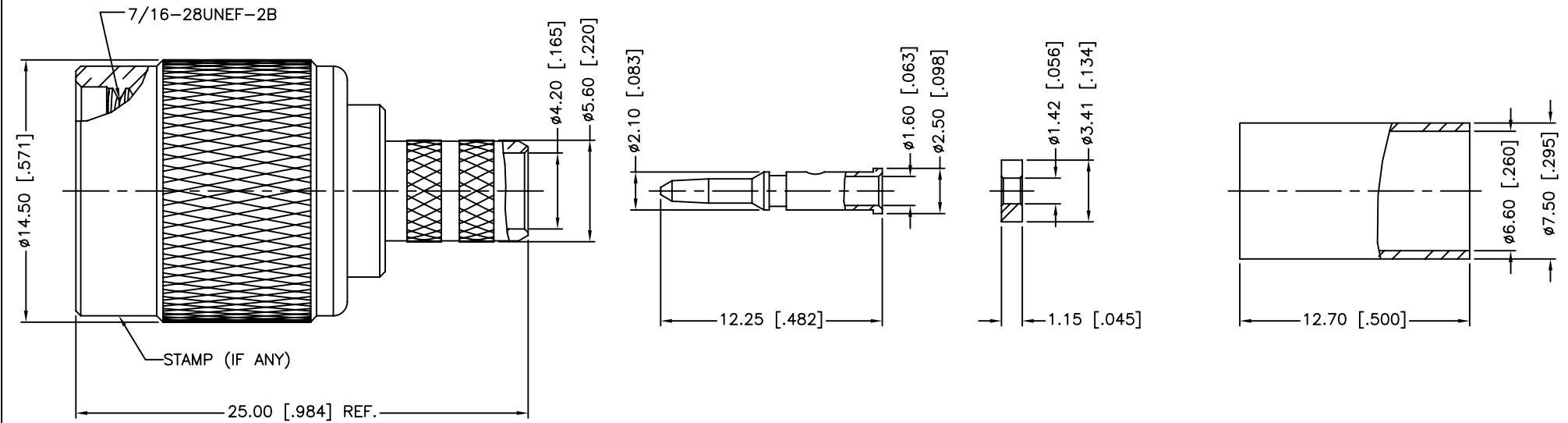

1. IMPEDANCE: 50 OHM
2. FREQUENCY RANGE: 0-11 GHZ
3. DIELECTRIC WITHSTANDING VOLTAGE: 1500 VRMS, MIN.
4. DURABILITY: 500 CYCLES MIN.
5. TEMPERATURE RANGE: -40°C TO +85°C
6. CRIMPED FERRULE
HEX. CRIMP SIZE .255"
7. CRIMPED CONTACT PIN
HEX. CRIMP SIZE .068"
8. SEE TABLE A FOR RECOMMENDED CABLE STRIPPING DIMENSIONS



TABLE A				
CABLE TYPE	DIMENSION A	DIMENSION B	DIMENSION C	SPACER REQUIRED
LMR-240	5.15 [.203]	7.70 [.303]	16.00 [.630]	YES
RG-8/X	4.00 [.157]	7.70 [.303]	16.00 [.630]	NO

NO	DESCRIPTION	MATERIAL	FINISH	QTY
10	FERRULE	BRASS	NICKEL	1
9	SPACER	PTFE	NATURAL	1
8	CONTACT PIN	BRASS	GOLD	1
7	WASHER	BRASS	NICKEL	1
6	RING	DELRIN	NATURAL	1
5	RETAINER RING	BRASS	NICKEL	1
4	GASKET	RUBBER	RED	1
3	INSULATOR	DELRIN	NATURAL	1
2	BODY	BRASS	NICKEL	1
1	SHELL	BRASS	NICKEL	1
	DESCRIPTION	MATERIAL	FINISH	QTY

UNLESS OTHERWISE SPECIFIED DIMENSIONS ARE IN MILLIMETERS. DIMENSIONS IN [] ARE IN INCHES AND FOR CUSTOMER REFERENCE ONLY.
UNLESS OTHERWISE SPECIFIED
TOLERANCES FOR MILLIMETERS ARE:
<0.5 ± 0.05mm
0.5 - 6mm ± 0.10mm
6 - 30mm ± 0.20mm
30 - 120mm ± 0.30mm
ANGLES ± 1°
UNLESS OTHERWISE SPECIFIED
TOLERANCES FOR INCHES ARE:
<.020 ± 0.002"
.020 - .236 ± 0.004"
.236 - 1.180 ± 0.007"
1.180 - 4.724 ± 0.012"
ANGLES ± 1°
DO NOT SCALE DRAWING

APPROVALS	DATE
DRAWN M.ZHANG	12/02/13
CHECKED	
ISSUED	
SHEET 1 OF 1	
CAD FILE C:/CONNEX/122408.DWG	

Amphenol Connex

PART DESCRIPTION
**TNC CRIMP PLUG
(FOR RG-8/X, LMR-240 CABLE)**

PART NO. **122408**

DWG. NO. 122408.DWG REV. E SIZE A SCALE NA