

REVISION RECORD				
REV	ECO	DESCRIPTION	DRFT	CHKD
△		add p/n.	By 07/05/05	
△		MODIFY LAYOUT	APR/06 02/15/06	

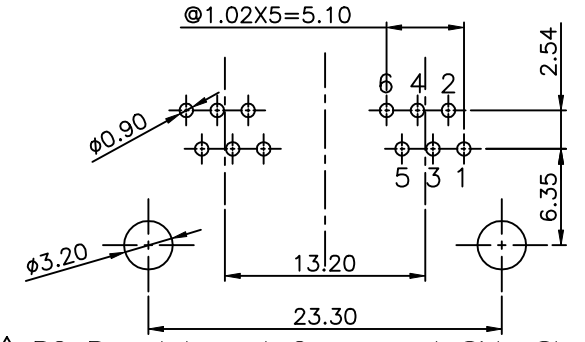
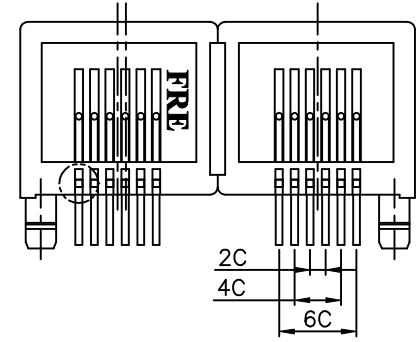
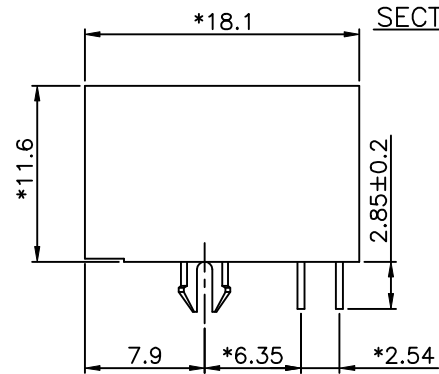
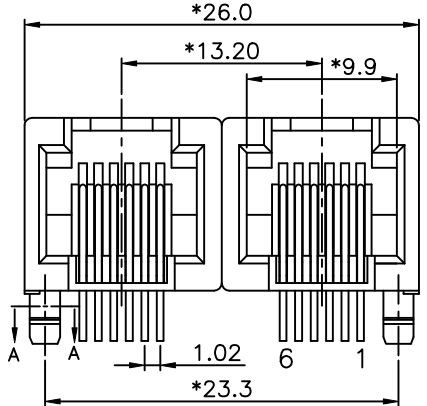
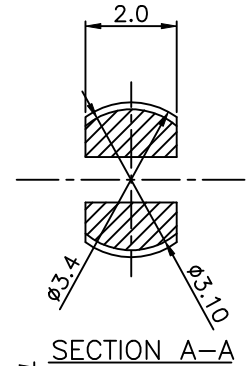
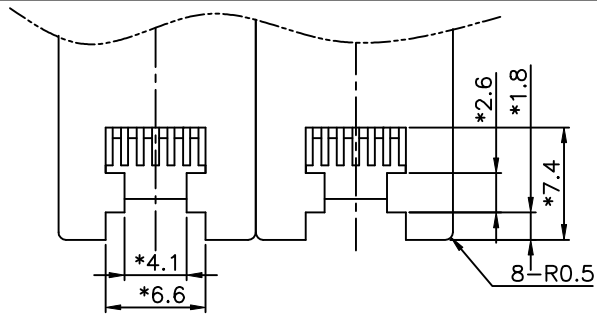

NOTES:

ELECTRICAL:

- VOLTAGE RATING : 150 VAC RMS.
- CURRENT RATING : 1.5 AMP.
- CONTACT RESISTANCE : 20 MILLIOHMS MAX.
- INSULATION RESISTANCE: 1000 MEGOHMS MIN @ 500 VDC.
- DIELECTRIC STRENGTH : 1000 VAC RMS 60Hz, 1MIN.

MECHANICAL:

- HOUSING MATERIAL : PBT+30%GF FR50 UL94V-0.
- CONTACT MATERIAL : PHOSPHOR BRONZE Ø0.46mm.
- PLATING : GOLD PLATING OVER NICKEL.
- OPERATING LIFE : 750 CYCLES MIN.
- PCB RETENTION PRE-SOLDER : 1 LB MIN.
- PCB RETENTION POST-SOLDER: 10 LBS MIN.

ENVIRONMENTAL:

- STORAGE : -40°C TO +85°C.
- OPERATION: -0°C TO 85°C.
- WAVE SOLDERING TEMPERATURE: 230°C TO 250°C (3-5SECONDS).

MATES WITH MODULAR PLUG CONFORMING TO FCC PART 68, SUBPART F.

PART NUMBER: E536X-30AXXX-L

NO. OF CONTACT	1- 3u"	2- 6u"
2-2C	3-15u"	4-30u"
4-4C	5-50u"	6-Pd 20u"
6-6C	F-GOLD FLASH	
	0F-PBT+30%GF BK	
	4F-FR50 BK	
	EF-FR50 GR(346C)	
	1B-PBT+30%GF GY △	

△ PC Board Layout Component Side Shown

DETACHED LISTS	MM (INCH)	DFTO CY	DATE 07/04/05	FULL RISE ELECTRONIC CO., LTD
	TOLERANCES EXCEPT AS NOTED	CHKDASHHELLY	DATE 2006/2/15	
	MM	MFO	DATE	
	.0 ±0.20 ±	APPVLLUSHENG	DATE 2006/2/15	
	.00 ±0.15 ±	MATERIAL :		TITLE
	.000 ±0.075 ±	QTY :		SIDE ENTRY DUAL PORTS 6P
ANGLES ±		FINISH :		DRAWING NO. GE533021-LC
THIRD ANGLE PROJECTION		SCALE :		/PART NO. SEE NOTE
				SIZE A3
				REV 2
				DO NOT SCALE DRAWING
				SHEET X OF Y