



1875 MHz Cavity Bandpass Filter

ANATECH ELECTRONICS INC
RF & Microwave Filters & Products

Part Number: AB1875B882



Electrical specifications

Center Frequency: 1875 MHz
Insertion loss @1875 MHz: <3 dB
Passband: 1863-1887 MHz
Rejection 1: 70 dB@1750 MHz
Rejection 2: 70 dB@2 GHz

Mechanical

Mounting Method: Threaded Mounting Holes
Connector Type: SMA Male/Female
Dimensions: 2.00" X 1.50" X 0.55" in

Environmental

Operating Temperature: -45 to +85° C
Storage Temperature: -55 to +95° C
Shock: 20 G. 11ms
Vibration: 20 G. 5 to 200 MHz

Outline Drawing:

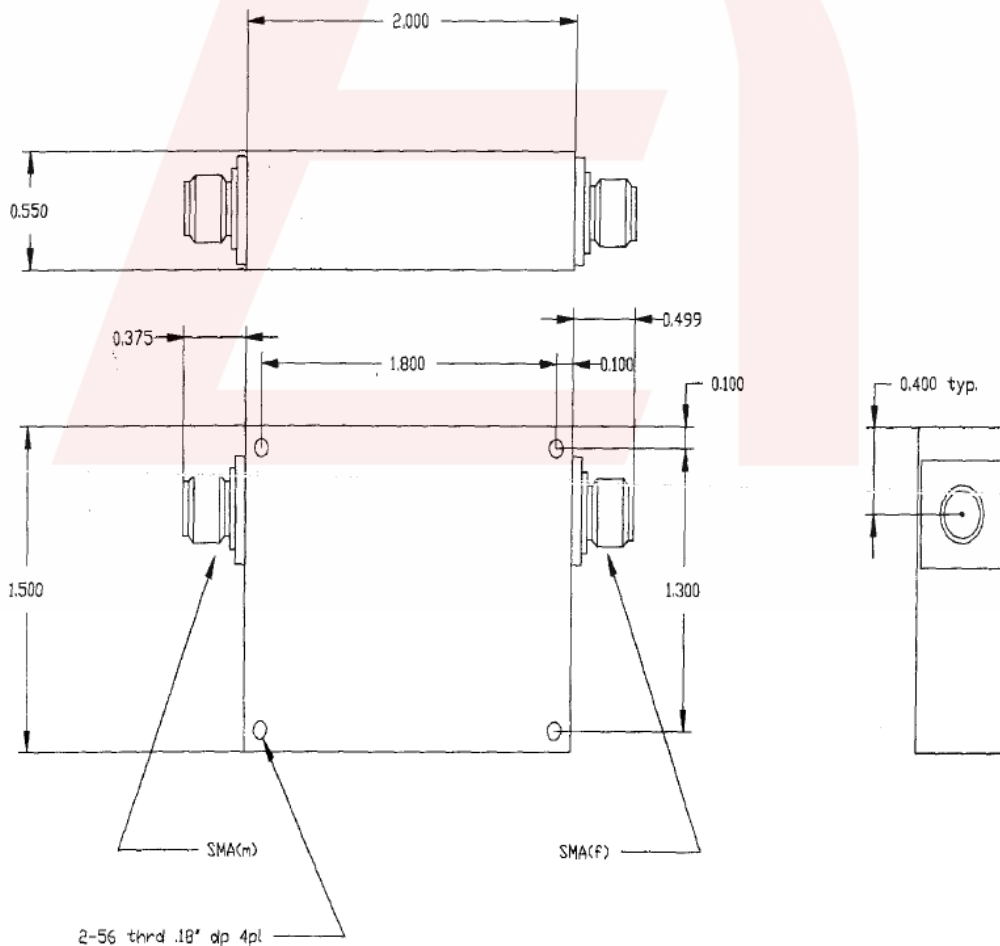



1875 MHz Cavity Bandpass Filter

ANATECH ELECTRONICS INC
RF & Microwave Filters & Products

Part Number: AB1875B882



Plot:

