

Model number

WCS-MB2

Mounting bracket for C profile, straight section

Features

- Mounting bracket for code rail, straight
- Installation in C profile rail 30 mm x 32 mm

Matching system components

WCS3-CS70-M1-1000FT

Code rail, stainless steel

WCS2-CS55-L1

Laminate type, 55 mm

WCS2-CS55-M1

Stainless steel type, 55 mm

WCS2-CS70-L1

Laminate type, 70 mm

WCS2-CS70-M1

Stainless steel type, 70 mm

WCS3-CS70-L*

Code rail, polyester laminate

WCS3-CS70-M1

Code rail, stainless steel

Dimensions

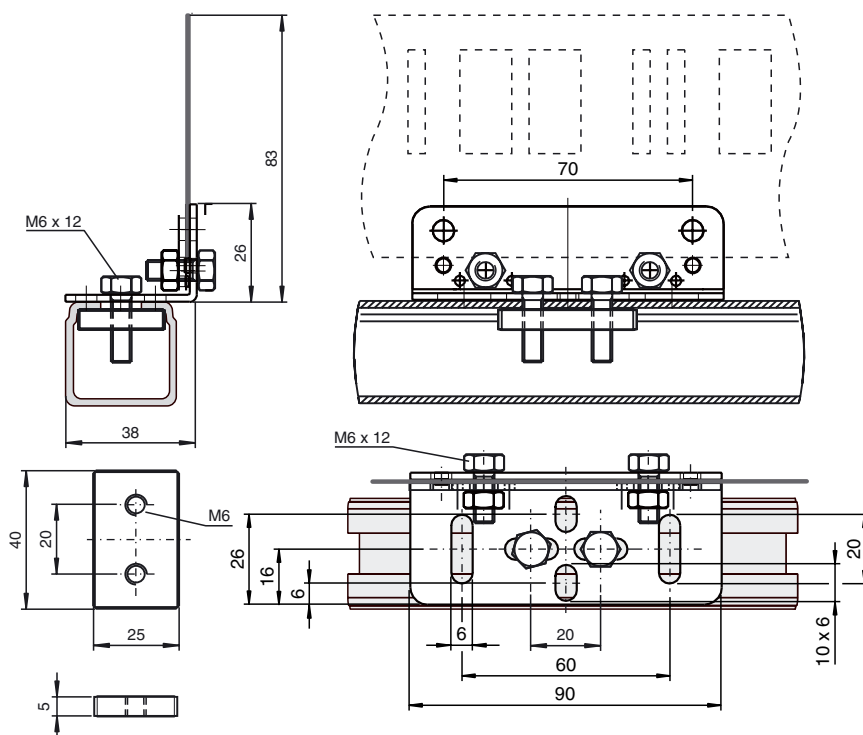

Technical data

Ambient conditions

Ambient temperature	-40 ... 100 °C (-40 ... 212 °F)
---------------------	---------------------------------

Mechanical specifications

Material thickness	2 mm
Material	Metal sheet (steel), zinc-plated
Mass	125 g (without fastening screws)