

## 3-Channel Linear LED Drivers

### Features

- $\pm 6\%$  Current Accuracy when  $V_{OUT}$  is between 4V and 15V
- 90V Standoff Voltage
- Separate Enable Pins for each Channel for PWM Dimming
- Overtemperature Protection
- 8-Lead SOIC (with Heat Slug) Package

### Applications

- LCD Backlighting
- Indicator Lamps

### General Description

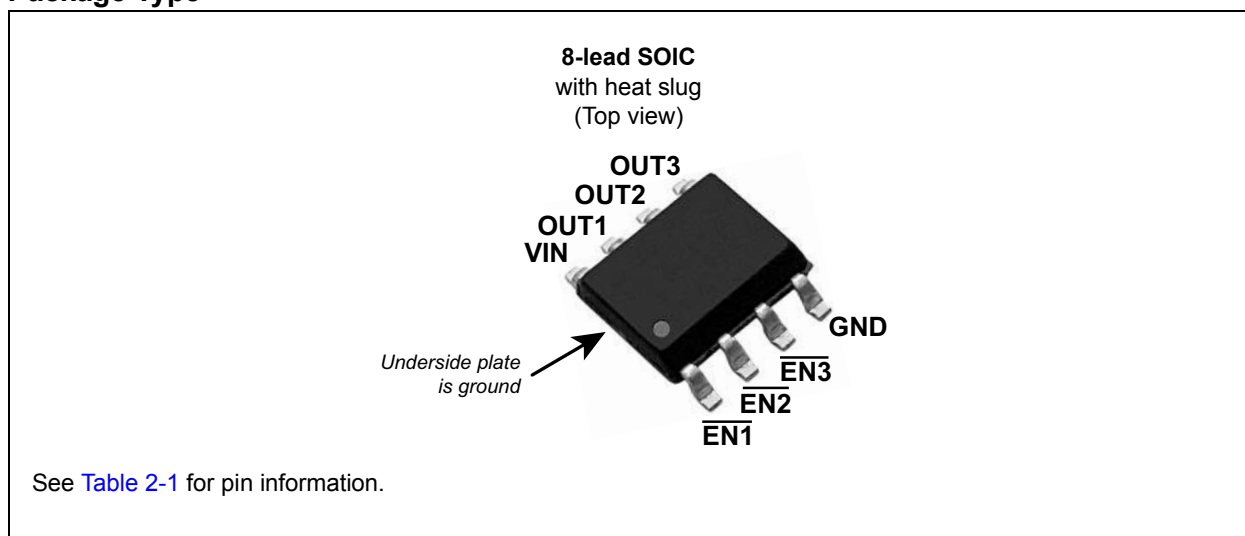
The CL320/CL325/CL330 are designed to drive three strings of LEDs at a constant current of 20 mA, 25 mA and 30 mA, respectively.

The drive current is fixed, with a  $\pm 6\%$  tolerance over a  $V_{OUT}$  range of 4V to 15V. Separate enable pins for each channel allow for PWM dimming, three-step linear dimming or individual disconnection of faulty LED strings.

Overtemperature protection circuitry shuts down all three channels when the nominal die temperature reaches 135°C. Normal operation resumes when the die temperature drops by 30°C.

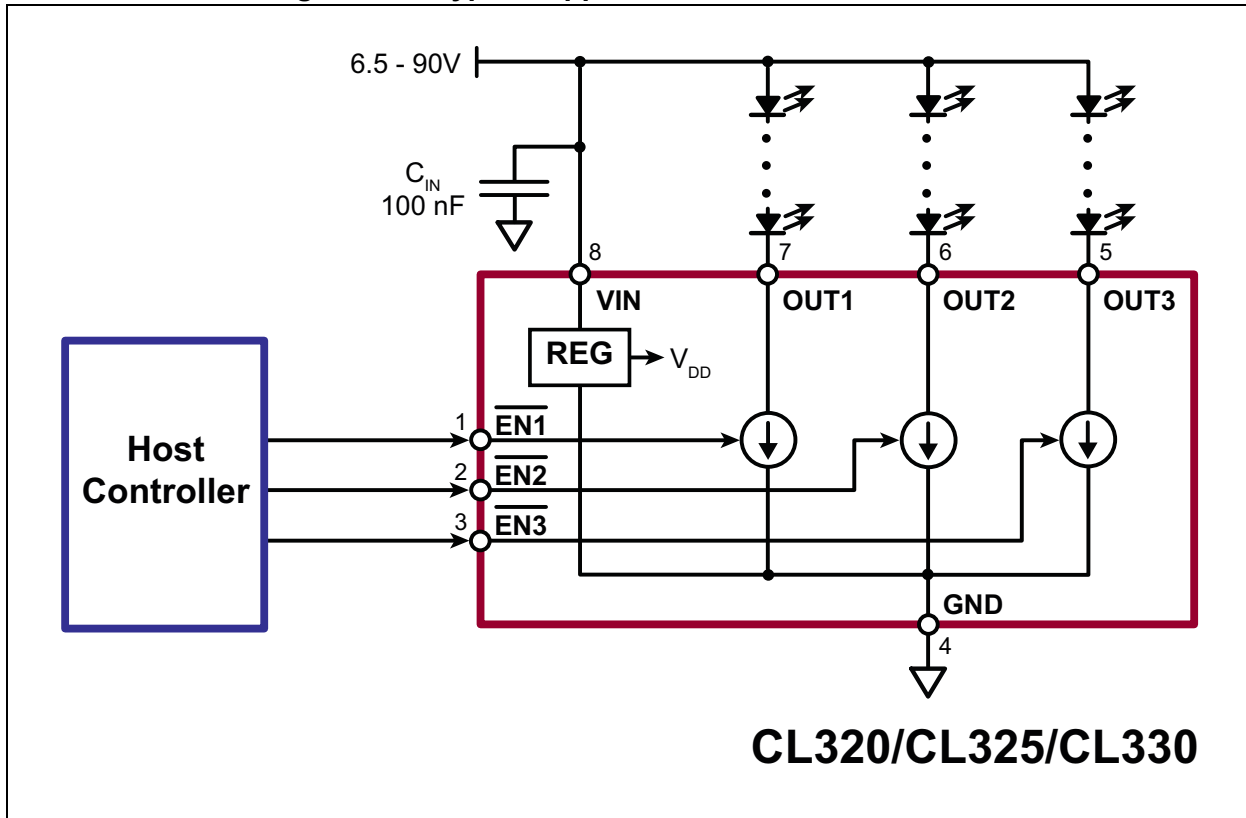
The CL320/CL325/CL330 are available in the 8-lead SOIC (with heat slug) package and require a single ceramic bypass capacitor which may be shared among several drivers.

### Package Type



# CL320/CL325/CL330

## Functional Block Diagram and Typical Application Circuit



## 1.0 ELECTRICAL CHARACTERISTICS

### Absolute Maximum Ratings†

|  |                 |
|--|-----------------|
| Supply Voltage, $V_{IN}$ .....                               | -0.5V to +100V  |
| Output Voltage, $V_{OUT}$ .....                              | -0.5V to +100V  |
| Enable Voltage, $V_{EN}$ .....                               | -0.5V to +6.5V  |
| Minimum Operating Junction Temperature, $T_J$ (Note 1) ..... | -40°C           |
| Storage Temperature, $T_S$ .....                             | -65°C to +150°C |

† **Notice:** Stresses above those listed under “Absolute Maximum Ratings” may cause permanent damage to the device. This is a stress rating only, and functional operation of the device at those or any other conditions above those indicated in the operational sections of this specification is not intended. Exposure to maximum rating conditions for extended periods may affect device reliability.

**Note 1:** Maximum junction temperature internally limited

### RECOMMENDED OPERATING CONDITIONS

| Electrical Specifications: All voltages with respect to GND pin |           |      |      |      |      |                     |
|---|-----------|------|------|------|------|---------------------|
| Parameter   | Sym.      | Min. | Typ. | Max. | Unit | Conditions          |
| Supply Voltage  | $V_{IN}$  | 6.5  | —    | 90   | V    |                     |
| Output Voltage  | $V_{OUT}$ | 4    | —    | 15   | V    | $\overline{EN} = 0$ |
|   |           |      |      | 90   |      | $\overline{EN} = 1$ |
| Enable Toggling Frequency                                       | $f_{EN}$  | 0    | —    | 100  | kHz  |                     |
| Operating Junction Temperature                                  | $T_J$     | -40  | —    | —    | °C   |                     |
| $V_{IN}$ Capacitor  | $C_{IN}$  | —    | 100  | —    | nF   |                     |

### ELECTRICAL CHARACTERISTICS

| Electrical Specifications: Over recommended operating conditions. $T_A = 25^\circ\text{C}$ unless otherwise noted. |                |               |      |      |               |                           |  |
|--|----------------|---------------|------|------|---------------|---------------------------|--|
| Parameter  | Sym.           | Min.          | Typ. | Max. | Unit          | Conditions                |  |
| $V_{IN}$ Supply Current  | $I_{IN}$       | —             | 220  | 250  | $\mu\text{A}$ | $\overline{EN}_{1-3} = 1$ |  |
|  |                | —             | 2.2  | 2.3  | mA            | $\overline{EN}_{1-3} = 0$ |  |
| Output Current, Off  | $I_{OUT(OFF)}$ | —             | 4    | 10   | $\mu\text{A}$ | $\overline{EN}_X = 1$     |  |
| Output Current, On   | CL320          | $I_{OUT(ON)}$ | —    | —    | 21.2          | mA                        | $\overline{EN}_X = 0, V_{OUT} = 0\text{V}-4\text{V}$   |
|  |                |               | 18.8 | 20   | 21.2          |                           | $\overline{EN}_X = 0, V_{OUT} = 4\text{V}-15\text{V}$  |
|  |                |               | 18   | 20   | 22            |                           | $\overline{EN}_X = 0, V_{OUT} = 15\text{V}-90\text{V}$ |
|  | CL325          |               | —    | —    | 26.5          |                           | $\overline{EN}_X = 0, V_{OUT} = 0\text{V}-4\text{V}$   |
|  |                |               | 23.5 | 25   | 26.5          |                           | $\overline{EN}_X = 0, V_{OUT} = 4\text{V}-15\text{V}$  |
|  |                |               | 22.5 | 25   | 27.5          |                           | $\overline{EN}_X = 0, V_{OUT} = 15\text{V}-90\text{V}$ |
|  | CL330          |               | —    | —    | 31.8          |                           | $\overline{EN}_X = 0, V_{OUT} = 0\text{V}-4\text{V}$   |
|  |                |               | 28.2 | 30   | 31.8          |                           | $\overline{EN}_X = 0, V_{OUT} = 4\text{V}-15\text{V}$  |
|  |                |               | 27   | 30   | 33            |                           | $\overline{EN}_X = 0, V_{OUT} = 15\text{V}-90\text{V}$ |
| Enable Voltage, On   | $V_{EN(ON)}$   | —             | —    | 0.8  | V             |                           |  |
| Enable Voltage, Off  | $V_{EN(OFF)}$  | 2.4           | —    | —    | V             |                           |  |
| Enable Input Capacitance   | $C_{EN}$       | —             | 5    | 10   | pF            |                           |  |

# CL320/CL325/CL330

## ELECTRICAL CHARACTERISTICS (CONTINUED)

**Electrical Specifications:** Over recommended operating conditions.  $T_A = 25^\circ\text{C}$  unless otherwise noted.

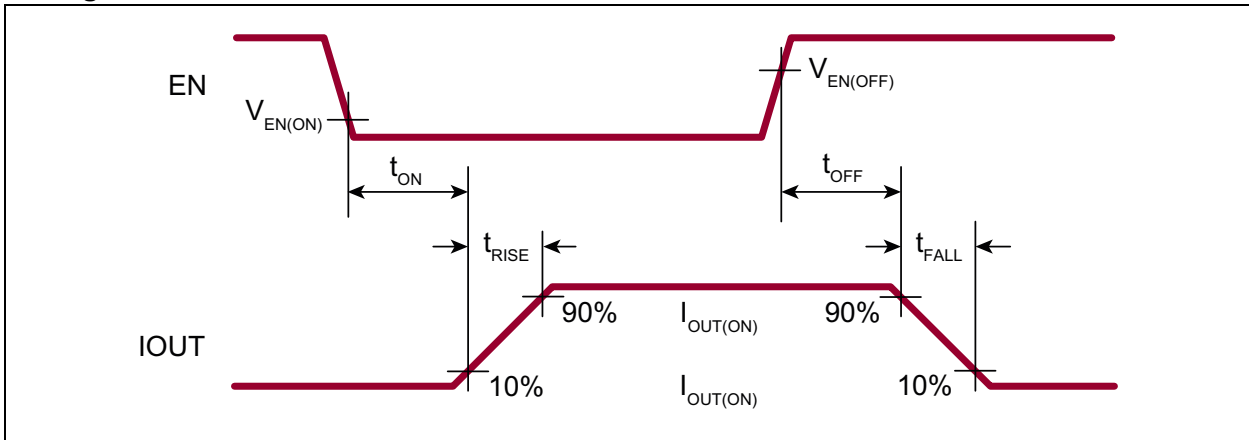
| Parameter                 | Sym.       | Min. | Typ. | Max. | Unit          | Conditions           |
|---------------------------|------------|------|------|------|---------------|----------------------|
| Enable Low Input Current  | $I_{ENL}$  | —    | —    | 1    | $\mu\text{A}$ | $V_{EN} = 0\text{V}$ |
| Enable High Input Current | $I_{ENH}$  | —    | —    | 1    | $\mu\text{A}$ | $V_{EN} = 5\text{V}$ |
| Enable on Delay           | $t_{ON}$   | —    | 2    | 2.4  | $\mu\text{s}$ |                      |
| Output Current Rise Time  | $t_{RISE}$ | —    | 1    | 1.2  | $\mu\text{s}$ |                      |
| Enable Off Delay          | $t_{OFF}$  | —    | 440  | 800  | ns            |                      |
| Output Current Fall Time  | $t_{FALL}$ | —    | 170  | 250  | ns            |                      |

## TEMPERATURE SPECIFICATIONS

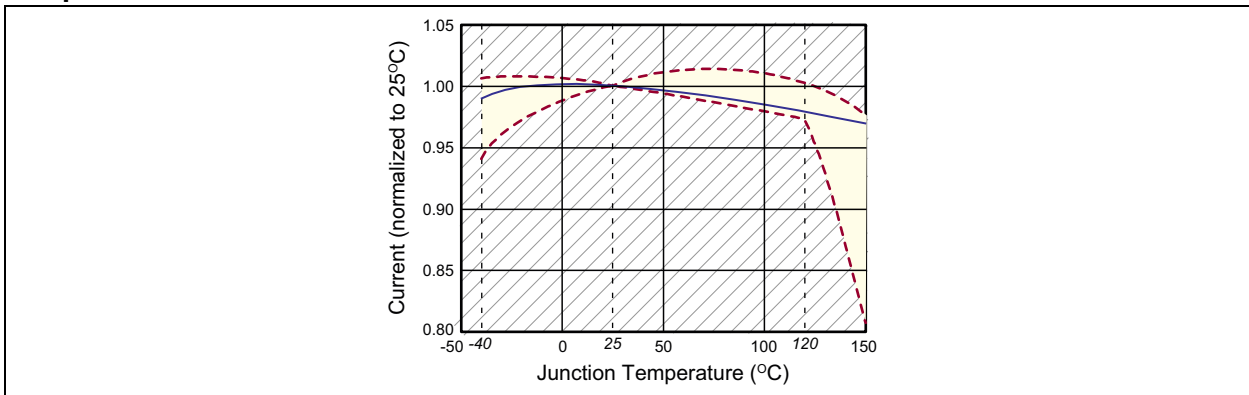
| Parameter                         | Sym.          | Min. | Typ. | Max. | Unit               | Conditions             |
|-----------------------------------|---------------|------|------|------|--------------------|------------------------|
| <b>TEMPERATURE RANGE</b>          |               |      |      |      |                    |                        |
| Operating Junction Temperature    | $T_J$         | -40  | —    | —    | $^\circ\text{C}$   |                        |
| Storage Temperature               | $T_S$         | -65  | —    | +150 | $^\circ\text{C}$   |                        |
| Overtemperature Limit             | $T_{LIM}$     | +120 | +135 | +150 | $^\circ\text{C}$   |                        |
| Overtemperature Hysteresis        | $T_{HYST}$    | —    | 30   | —    | $^\circ\text{C}$   |                        |
| <b>PACKAGE THERMAL RESISTANCE</b> |               |      |      |      |                    |                        |
| 8-lead SOIC (with heat slug)      | $\theta_{JA}$ | —    | 84   | —    | $^\circ\text{C/W}$ | <a href="#">Note 1</a> |

**Note 1:** Mounted on JEDEC test PCB (2s 2p)

## Timing Waveforms

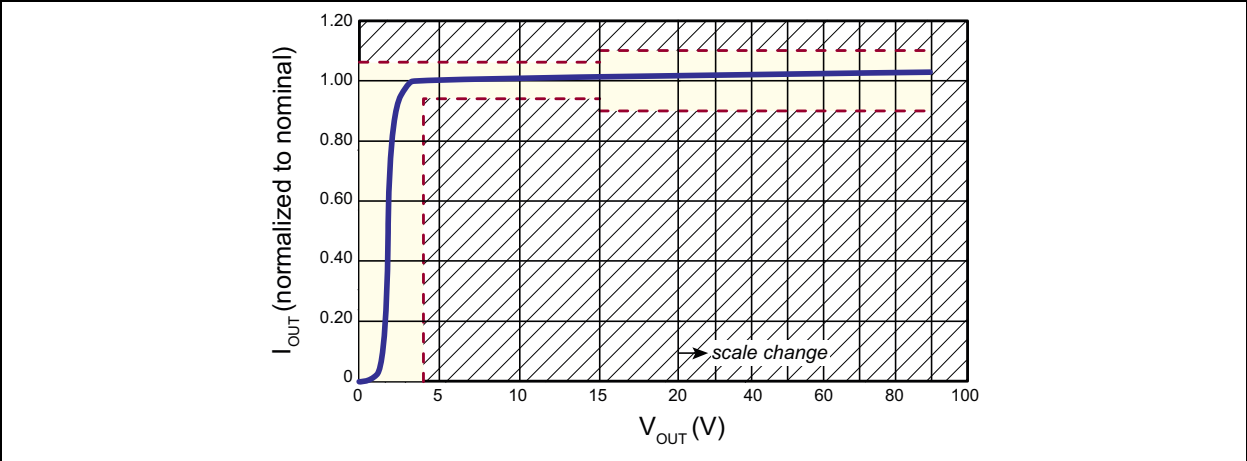


## Temperature Effects

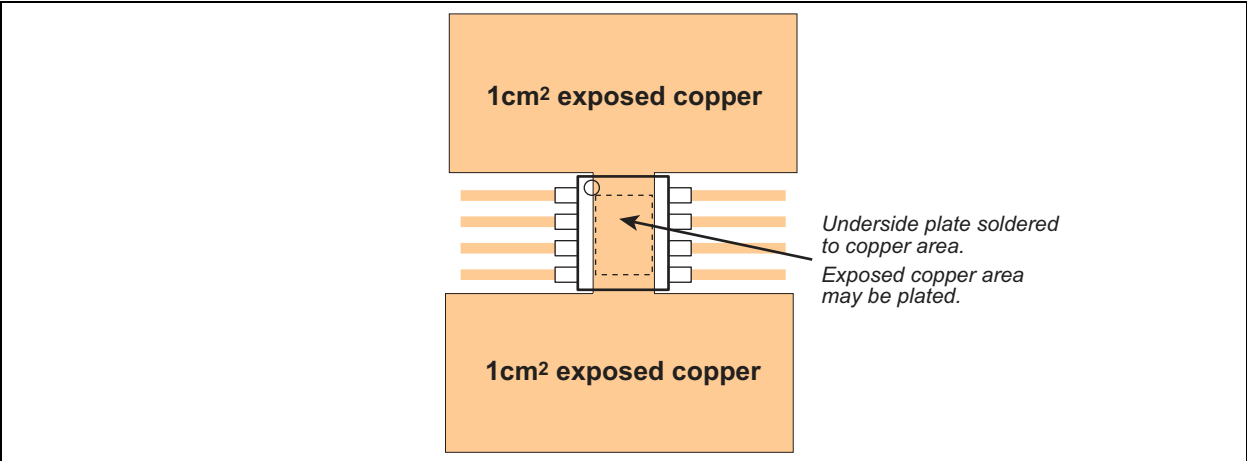


# CL320/CL325/CL330

## Load Regulation



## Recommended PCB Layout



## 2.0 PIN DESCRIPTION

The pin details of CL320/CL325/CL330 are listed on [Table 2-1](#). Refer to [Package Type](#) for the location of the pins.

**TABLE 2-1: PIN FUNCTION TABLE**

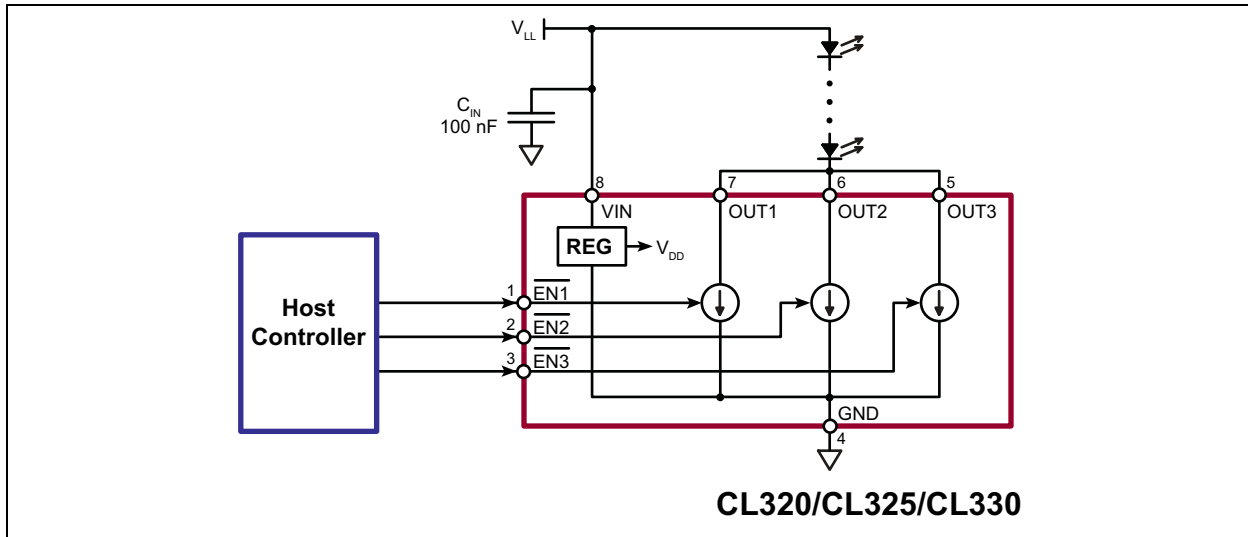
| Pin Number      | Pin Name                | Description  |
|-----------------|-------------------------|--|
| 1               | $\overline{\text{EN1}}$ | Output enable, active low  |
| 2               | $\overline{\text{EN2}}$ |  |
| 3               | $\overline{\text{EN3}}$ |  |
| 4               | GND                     | Circuit common   |
| 5               | OUT3                    | Constant current output (sinking). Connect the cathodes of the LEDs to these pins.   |
| 6               | OUT2                    |  |
| 7               | OUT1                    |  |
| 8               | VIN                     | Supply voltage 6.5V to 90V. Bypass locally with a 100 nF capacitor to ground.  |
| Underside Plate | GND                     | The exposed underside plate is internally connected to the GND pin. The plate may either be left floating or connected to ground. Solder the plate to an exposed copper area on the PCB for heatsinking purposes. (See <a href="#">Recommended PCB Layout</a> .) |

# CL320/CL325/CL330

## 3.0 DETAILED DESCRIPTION

### 3.1 Higher LED Current

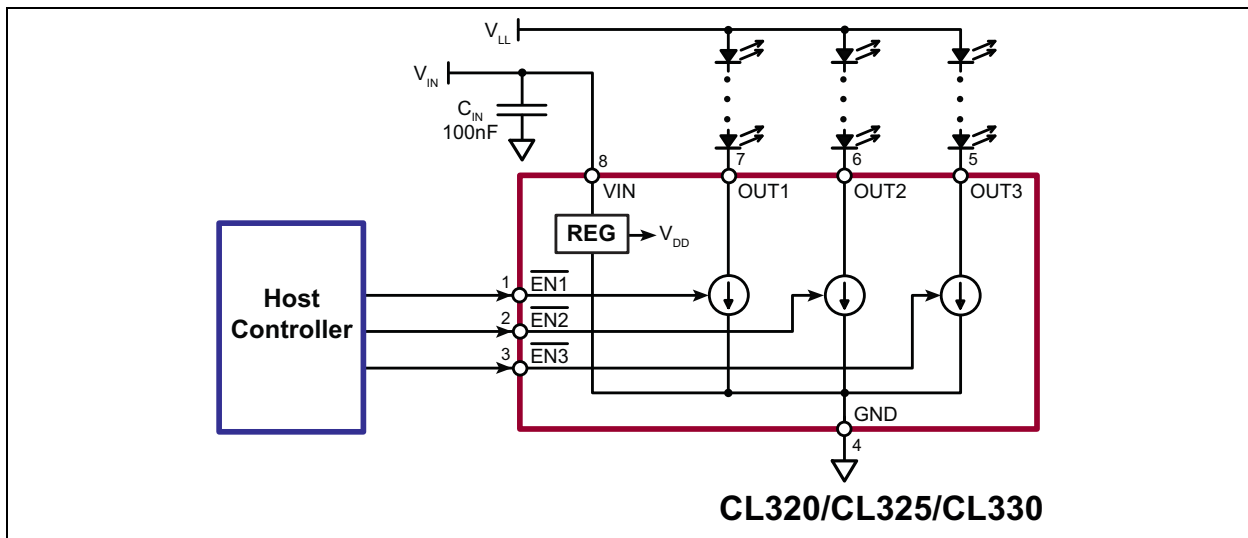
By paralleling outputs, higher LED currents can be achieved. In addition, linear dimming in three discrete steps may be obtained by enabling 1, 2 or 3 outputs.



**FIGURE 3-1:** Paralleling Outputs of the CL320/CL325/CL330 LED Drivers.

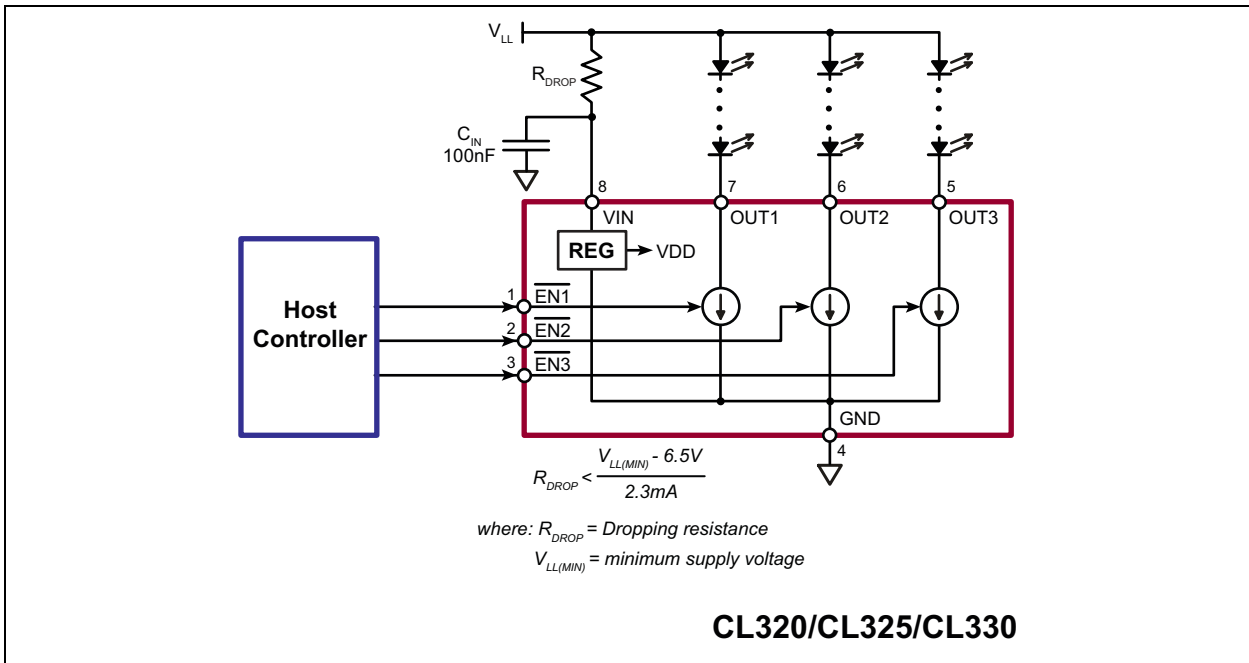
### 3.2 Lower Power Dissipation in the CL320/CL325/CL330

Power dissipation in the CL320/CL325/CL330 can be lowered in multiple ways. The following figures indicate some of the possible means to reduce power dissipation in the IC. Refer to [Figure 3-2](#), [Figure 3-3](#) and [Figure 3-4](#).

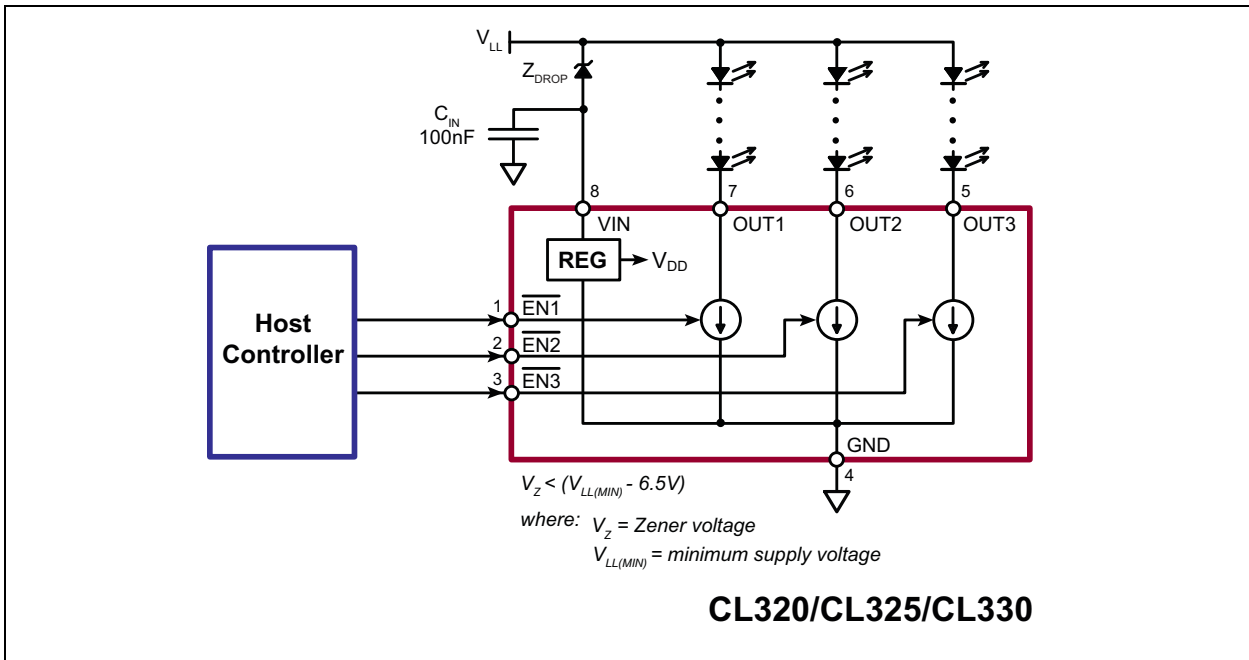


**FIGURE 3-2:** Using a Separate Voltage Source for V<sub>IN</sub> that is lower than V<sub>LL</sub>.





**FIGURE 3-3:** Using an External Resistor in Series with the  $V_{IN}$  pin.

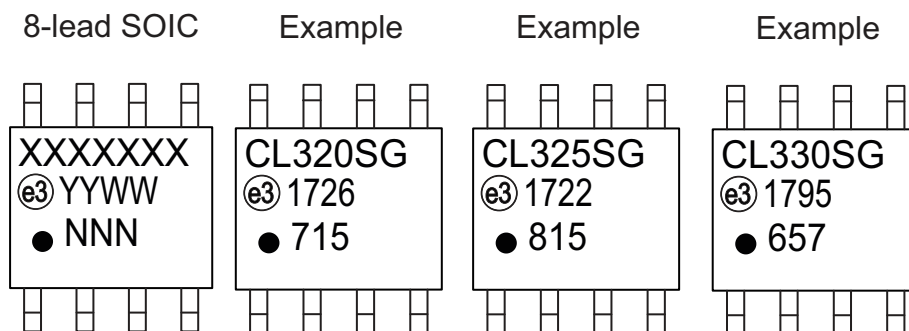


**FIGURE 3-4:** Using an External Zener Diode in Series with the  $V_{IN}$  pin.

# CL320/CL325/CL330

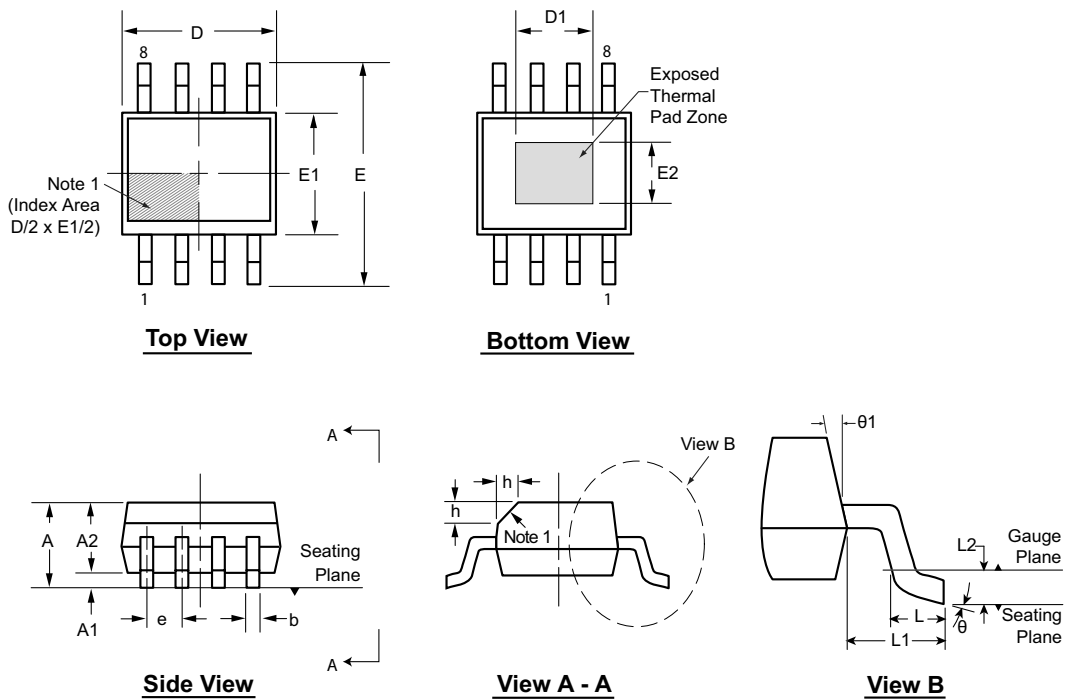
## 4.0 PACKAGING INFORMATION

### 4.1 Package Marking Information



|                |  |  |
|----------------|--|--|
| <b>Legend:</b> | XX...X   | Product Code or Customer-specific information  |
|                | Y  | Year code (last digit of calendar year)  |
|                | YY   | Year code (last 2 digits of calendar year)   |
|                | WW   | Week code (week of January 1 is week '01')   |
|                | NNN  | Alphanumeric traceability code   |
|                | (e3)   | Pb-free JEDEC® designator for Matte Tin (Sn)   |
|                | *  | This package is Pb-free. The Pb-free JEDEC designator (e3) can be found on the outer packaging for this package. |
| <b>Note:</b>   | In the event the full Microchip part number cannot be marked on one line, it will be carried over to the next line, thus limiting the number of available characters for product code or customer-specific information. Package may or not include the corporate logo. |  |

## 8-Lead SOIC (Narrow Body w/Heat Slug) Package Outline (SG) 4.90x3.90mm body, 1.70mm height (max), 1.27mm pitch



Note: For the most current package drawings, see the Microchip Packaging Specification at [www.microchip.com/packaging](http://www.microchip.com/packaging).

**Note:**

1. If optional chamfer feature is not present, a Pin 1 identifier must be located in the index area indicated. The Pin 1 identifier can be: a molded mark/identifier; an embedded metal marker; or a printed indicator.

| Symbol         | A   | A1    | A2   | b     | D    | D1    | E     | E1    | E2    | e     | h        | L    | L1   | L2       | θ    | θ1   |    |     |
|----------------|-----|-------|------|-------|------|-------|-------|-------|-------|-------|----------|------|------|----------|------|------|----|-----|
| Dimension (mm) | MIN | 1.25* | 0.00 | 1.25  | 0.31 | 4.80* | 3.30† | 5.80* | 3.80* | 2.29† | 1.27 BSC | 0.25 | 0.40 | 1.04 REF | 0.25 | 0°   | 5° |     |
|                | NOM | -     | -    | -     | 4.90 | -     | 6.00  | 3.90  | -     | -     |          | -    | -    |          | -    | -    | -  | -   |
|                | MAX | 1.70  | 0.15 | 1.55* | 0.51 | 5.00* | 3.81† | 6.20* | 4.00* | 2.79† |          | 0.50 | 1.27 |          | -    | 0.25 | 8° | 15° |

JEDEC Registration MS-012, Variation BA, Issue E, Sept. 2005.

\* This dimension is not specified in the JEDEC drawing.

† This dimension differs from the JEDEC drawing.

Drawings not to scale.

# CL320/CL325/CL330

---

NOTES:

## APPENDIX A: REVISION HISTORY

### Revision A (May 2017)

- Consolidated and converted Supertex Doc# DSFP-CL320, Doc# DSFP-CL325 and Doc# DSFP-CL330 to Microchip DS20005599A
- Changed package marking format
- Changed the quantity of the SG package from 2500/Reel to 3300/Reel
- Made minor text changes throughout the document

# CL320/CL325/CL330

## PRODUCT IDENTIFICATION SYSTEM

To order or obtain information, e.g., on pricing or delivery, contact your local Microchip representative or sales office.

| <u>PART NO.</u> | <u>XX</u>       | - | <u>X</u>                              | - | <u>X</u>   |
|-----------------|-----------------|---|---------------------------------------|---|------------|
| Device          | Package Options |   | Environmental                         |   | Media Type |
| Devices:        | CL320           | = | 3-Channel, 20 mA Linear LED Driver    |   |            |
|                 | CL325           | = | 3-Channel, 25 mA Linear LED Driver    |   |            |
|                 | CL330           | = | 3-Channel, 30 mA Linear LED Driver    |   |            |
| Package:        | SG              | = | 8-lead SOIC (with Heat Slug)          |   |            |
| Environmental:  | G               | = | Lead (Pb)-free/RoHS-compliant Package |   |            |
| Media Type:     | (blank)         | = | 3300/Reel for an SG Package           |   |            |

**Examples:**

a) CL320SG-G: 3-Channel, 20 mA Linear LED Driver, 8-lead SOIC Package, 3300/Reel

b) CL325SG-G: 3-Channel, 25 mA Linear LED Driver, 8-lead SOIC Package, 3300/Reel

c) CL330SG-G: 3-Channel, 30 mA Linear LED Driver, 8-lead SOIC Package, 3300/Reel

---

---

**Note the following details of the code protection feature on Microchip devices:**

- Microchip products meet the specification contained in their particular Microchip Data Sheet.
- Microchip believes that its family of products is one of the most secure families of its kind on the market today, when used in the intended manner and under normal conditions.
- There are dishonest and possibly illegal methods used to breach the code protection feature. All of these methods, to our knowledge, require using the Microchip products in a manner outside the operating specifications contained in Microchip's Data Sheets. Most likely, the person doing so is engaged in theft of intellectual property.
- Microchip is willing to work with the customer who is concerned about the integrity of their code.
- Neither Microchip nor any other semiconductor manufacturer can guarantee the security of their code. Code protection does not mean that we are guaranteeing the product as “unbreakable.”

Code protection is constantly evolving. We at Microchip are committed to continuously improving the code protection features of our products. Attempts to break Microchip's code protection feature may be a violation of the Digital Millennium Copyright Act. If such acts allow unauthorized access to your software or other copyrighted work, you may have a right to sue for relief under that Act.

---

Information contained in this publication regarding device applications and the like is provided only for your convenience and may be superseded by updates. It is your responsibility to ensure that your application meets with your specifications. MICROCHIP MAKES NO REPRESENTATIONS OR WARRANTIES OF ANY KIND WHETHER EXPRESS OR IMPLIED, WRITTEN OR ORAL, STATUTORY OR OTHERWISE, RELATED TO THE INFORMATION, INCLUDING BUT NOT LIMITED TO ITS CONDITION, QUALITY, PERFORMANCE, MERCHANTABILITY OR FITNESS FOR PURPOSE. Microchip disclaims all liability arising from this information and its use. Use of Microchip devices in life support and/or safety applications is entirely at the buyer's risk, and the buyer agrees to defend, indemnify and hold harmless Microchip from any and all damages, claims, suits, or expenses resulting from such use. No licenses are conveyed, implicitly or otherwise, under any Microchip intellectual property rights unless otherwise stated.

*Microchip received ISO/TS-16949:2009 certification for its worldwide headquarters, design and wafer fabrication facilities in Chandler and Tempe, Arizona; Gresham, Oregon and design centers in California and India. The Company's quality system processes and procedures are for its PIC® MCUs and dsPIC® DSCs, KEELOQ® code hopping devices, Serial EEPROMs, microperipherals, nonvolatile memory and analog products. In addition, Microchip's quality system for the design and manufacture of development systems is ISO 9001:2000 certified.*

**QUALITY MANAGEMENT SYSTEM  
CERTIFIED BY DNV  
= ISO/TS 16949 =**

### Trademarks

The Microchip name and logo, the Microchip logo, AnyRate, AVR, AVR logo, AVR Freaks, BeaconThings, BitCloud, CryptoMemory, CryptoRF, dsPIC, FlashFlex, flexPWR, Helder, JukeBlox, KEELOQ, KEELOQ logo, Klear, LANCheck, LINK MD, maXStylus, maXTouch, MediaLB, megaAVR, MOST, MOST logo, MPLAB, OptoLyzer, PIC, picoPower, PICSTART, PIC32 logo, Prochip Designer, QTouch, RightTouch, SAM-BA, SpyNIC, SST, SST Logo, SuperFlash, tinyAVR, UNI/O, and XMEGA are registered trademarks of Microchip Technology Incorporated in the U.S.A. and other countries.

ClockWorks, The Embedded Control Solutions Company, EtherSynch, Hyper Speed Control, HyperLight Load, IntelliMOS, mTouch, Precision Edge, and Quiet-Wire are registered trademarks of Microchip Technology Incorporated in the U.S.A.

Adjacent Key Suppression, AKS, Analog-for-the-Digital Age, Any Capacitor, AnyIn, AnyOut, BodyCom, chipKIT, chipKIT logo, CodeGuard, CryptoAuthentication, CryptoCompanion, CryptoController, dsPICDEM, dsPICDEM.net, Dynamic Average Matching, DAM, ECAN, EtherGREEN, In-Circuit Serial Programming, ICSP, Inter-Chip Connectivity, JitterBlocker, KlearNet, KlearNet logo, Mindi, MiWi, motorBench, MPASM, MPF, MPLAB Certified logo, MPLIB, MPLINK, MultiTRAK, NetDetach, Omniscient Code Generation, PICDEM, PICDEM.net, PICKit, PICTail, PureSilicon, QMatrix, RightTouch logo, REAL ICE, Ripple Blocker, SAM-ICE, Serial Quad I/O, SMART-I.S., SQI, SuperSwitcher, SuperSwitcher II, Total Endurance, TSHARC, USBCheck, VariSense, ViewSpan, WiperLock, Wireless DNA, and ZENA are trademarks of Microchip Technology Incorporated in the U.S.A. and other countries.

SQTP is a service mark of Microchip Technology Incorporated in the U.S.A.

Silicon Storage Technology is a registered trademark of Microchip Technology Inc. in other countries.

GestIC is a registered trademark of Microchip Technology Germany II GmbH & Co. KG, a subsidiary of Microchip Technology Inc., in other countries.

All other trademarks mentioned herein are property of their respective companies.

© 2017, Microchip Technology Incorporated, All Rights Reserved.  
ISBN: 978-1-5224-1719-4



# MICROCHIP

## Worldwide Sales and Service

### AMERICAS

**Corporate Office**  
2355 West Chandler Blvd.  
Chandler, AZ 85224-6199  
Tel: 480-792-7200  
Fax: 480-792-7277  
Technical Support:  
<http://www.microchip.com/support>  
Web Address:  
[www.microchip.com](http://www.microchip.com)

**Atlanta**  
Duluth, GA  
Tel: 678-957-9614  
Fax: 678-957-1455

**Austin, TX**  
Tel: 512-257-3370

**Boston**  
Westborough, MA  
Tel: 774-760-0087  
Fax: 774-760-0088

**Chicago**  
Itasca, IL  
Tel: 630-285-0071  
Fax: 630-285-0075

**Dallas**  
Addison, TX  
Tel: 972-818-7423  
Fax: 972-818-2924

**Detroit**  
Novi, MI  
Tel: 248-848-4000

**Houston, TX**  
Tel: 281-894-5983

**Indianapolis**  
Noblesville, IN  
Tel: 317-773-8323  
Fax: 317-773-5453  
Tel: 317-536-2380

**Los Angeles**  
Mission Viejo, CA  
Tel: 949-462-9523  
Fax: 949-462-9608  
Tel: 951-273-7800

**Raleigh, NC**  
Tel: 919-844-7510

**New York, NY**  
Tel: 631-435-6000

**San Jose, CA**  
Tel: 408-735-9110  
Tel: 408-436-4270

**Canada - Toronto**  
Tel: 905-695-1980  
Fax: 905-695-2078

### ASIA/PACIFIC

**Asia Pacific Office**  
Suites 3707-14, 37th Floor  
Tower 6, The Gateway  
Harbour City, Kowloon

**Hong Kong**  
Tel: 852-2943-5100  
Fax: 852-2401-3431

**Australia - Sydney**  
Tel: 61-2-9868-6733  
Fax: 61-2-9868-6755

**China - Beijing**  
Tel: 86-10-8569-7000  
Fax: 86-10-8528-2104

**China - Chengdu**  
Tel: 86-28-8665-5511  
Fax: 86-28-8665-7889

**China - Chongqing**  
Tel: 86-23-8980-9588  
Fax: 86-23-8980-9500

**China - Dongguan**  
Tel: 86-769-8702-9880

**China - Guangzhou**  
Tel: 86-20-8755-8029

**China - Hangzhou**  
Tel: 86-571-8792-8115  
Fax: 86-571-8792-8116

**China - Hong Kong SAR**  
Tel: 852-2943-5100  
Fax: 852-2401-3431

**China - Nanjing**  
Tel: 86-25-8473-2460  
Fax: 86-25-8473-2470

**China - Qingdao**  
Tel: 86-532-8502-7355  
Fax: 86-532-8502-7205

**China - Shanghai**  
Tel: 86-21-3326-8000  
Fax: 86-21-3326-8021

**China - Shenyang**  
Tel: 86-24-2334-2829  
Fax: 86-24-2334-2393

**China - Shenzhen**  
Tel: 86-755-8864-2200  
Fax: 86-755-8203-1760

**China - Wuhan**  
Tel: 86-27-5980-5300  
Fax: 86-27-5980-5118

**China - Xian**  
Tel: 86-29-8833-7252  
Fax: 86-29-8833-7256

### ASIA/PACIFIC

**China - Xiamen**  
Tel: 86-592-2388138  
Fax: 86-592-2388130

**China - Zhuhai**  
Tel: 86-756-3210040  
Fax: 86-756-3210049

**India - Bangalore**  
Tel: 91-80-3090-4444  
Fax: 91-80-3090-4123

**India - New Delhi**  
Tel: 91-11-4160-8631  
Fax: 91-11-4160-8632

**India - Pune**  
Tel: 91-20-3019-1500

**Japan - Osaka**  
Tel: 81-6-6152-7160  
Fax: 81-6-6152-9310

**Japan - Tokyo**  
Tel: 81-3-6880-3770  
Fax: 81-3-6880-3771

**Korea - Daegu**  
Tel: 82-53-744-4301  
Fax: 82-53-744-4302

**Korea - Seoul**  
Tel: 82-2-554-7200  
Fax: 82-2-558-5932 or  
82-2-558-5934

**Malaysia - Kuala Lumpur**  
Tel: 60-3-6201-9857  
Fax: 60-3-6201-9859

**Malaysia - Penang**  
Tel: 60-4-227-8870  
Fax: 60-4-227-4068

**Philippines - Manila**  
Tel: 63-2-634-9065  
Fax: 63-2-634-9069

**Singapore**  
Tel: 65-6334-8870  
Fax: 65-6334-8850

**Taiwan - Hsin Chu**  
Tel: 886-3-5778-366  
Fax: 886-3-5770-955

**Taiwan - Kaohsiung**  
Tel: 886-7-213-7830

**Taiwan - Taipei**  
Tel: 886-2-2508-8600  
Fax: 886-2-2508-0102

**Thailand - Bangkok**  
Tel: 66-2-694-1351  
Fax: 66-2-694-1350

### EUROPE

**Austria - Wels**  
Tel: 43-7242-2244-39  
Fax: 43-7242-2244-393

**Denmark - Copenhagen**  
Tel: 45-4450-2828  
Fax: 45-4485-2829

**Finland - Espoo**  
Tel: 358-9-4520-820

**France - Paris**  
Tel: 33-1-69-53-63-20  
Fax: 33-1-69-30-90-79

**France - Saint Cloud**  
Tel: 33-1-30-60-70-00

**Germany - Garching**  
Tel: 49-8931-9700

**Germany - Haan**  
Tel: 49-2129-3766400

**Germany - Heilbronn**  
Tel: 49-7131-67-3636

**Germany - Karlsruhe**  
Tel: 49-721-625370

**Germany - Munich**  
Tel: 49-89-627-144-0  
Fax: 49-89-627-144-44

**Germany - Rosenheim**  
Tel: 49-8031-354-560

**Israel - Ra'anana**  
Tel: 972-9-744-7705

**Italy - Milan**  
Tel: 39-0331-742611  
Fax: 39-0331-466781

**Italy - Padova**  
Tel: 39-049-7625286

**Netherlands - Drunen**  
Tel: 31-416-690399  
Fax: 31-416-690340

**Norway - Trondheim**  
Tel: 47-7289-7561

**Poland - Warsaw**  
Tel: 48-22-3325737

**Romania - Bucharest**  
Tel: 40-21-407-87-50

**Spain - Madrid**  
Tel: 34-91-708-08-90  
Fax: 34-91-708-08-91

**Sweden - Gothenberg**  
Tel: 46-31-704-60-40

**Sweden - Stockholm**  
Tel: 46-8-5090-4654

**UK - Wokingham**  
Tel: 44-118-921-5800  
Fax: 44-118-921-5820