

THIS INFORMATION IS CONFIDENTIAL AND IS TO BE USED ONLY FOR THE PURPOSES SPECIFIED IN THE ORIGINAL CONTRACT. IT IS NOT TO BE REPRODUCED OR TRANSMITTED IN ANY FORM OR BY ANY MEANS, ELECTRONIC OR MECHANICAL, INCLUDING PHOTOCOPYING, RECORDING, OR BY ANY INFORMATION STORAGE AND RETRIEVAL SYSTEM.

THIS INFORMATION IS CONFIDENTIAL AND IS TO BE USED ONLY FOR THE PURPOSES SPECIFIED IN THE ORIGINAL CONTRACT. IT IS NOT TO BE REPRODUCED OR TRANSMITTED IN ANY FORM OR BY ANY MEANS, ELECTRONIC OR MECHANICAL, INCLUDING PHOTOCOPYING, RECORDING, OR BY ANY INFORMATION STORAGE AND RETRIEVAL SYSTEM.

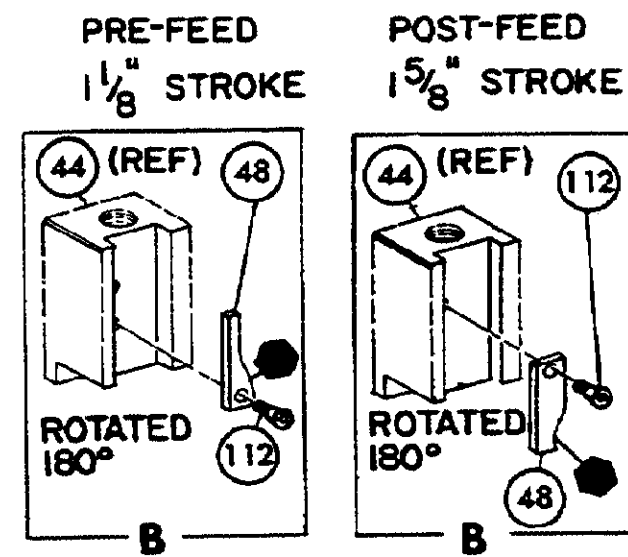
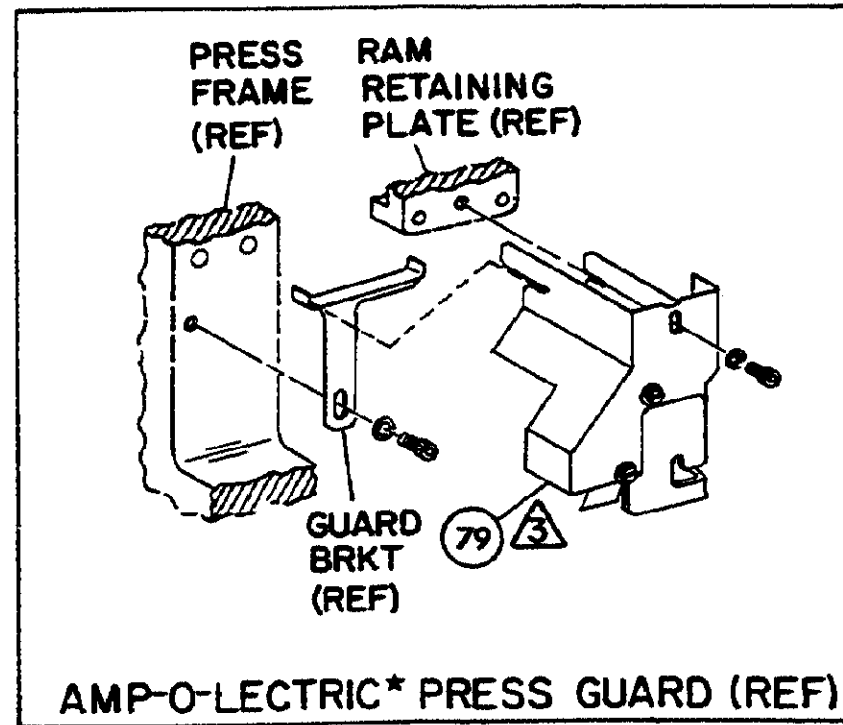
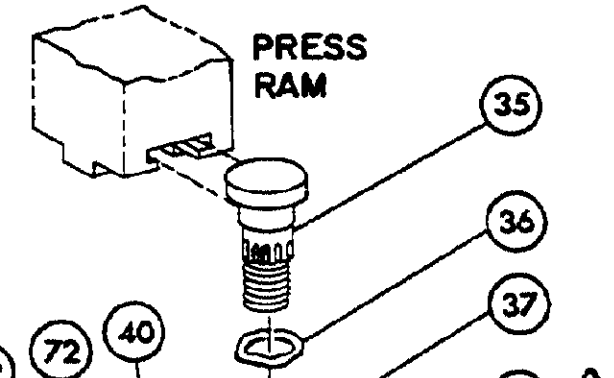
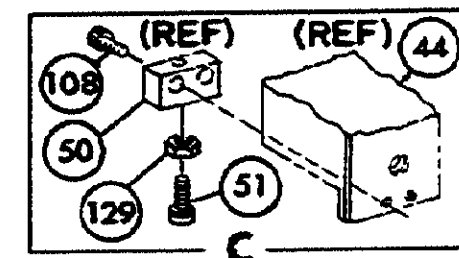
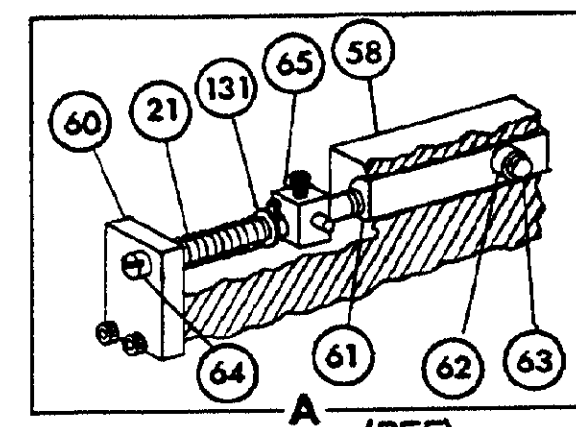

NOTES:

1- ONLY THE ITEMS WITH QUANTITIES SPECIFIED ON PARTS LIST ARE USED ON THIS APPLICATOR.

2- USED IN PLACE OF ITEM 38 WHEN INSULATION CRIMP IS NOT USED.

3- GUARD MUST BE IN PLACE WHEN OPERATING APPLICATOR IN AMP-O-LECTRIC PRESS.

4. PART NO. WITH QTY OF REF SPECIFIED ARE USED ON ITEM 46.

KEY:

■ RECOMMENDED SPARE PARTS

▲ LUBRICATE DAILY USING NO. 20 MACHINE OIL.

● GREASE LIGHTLY

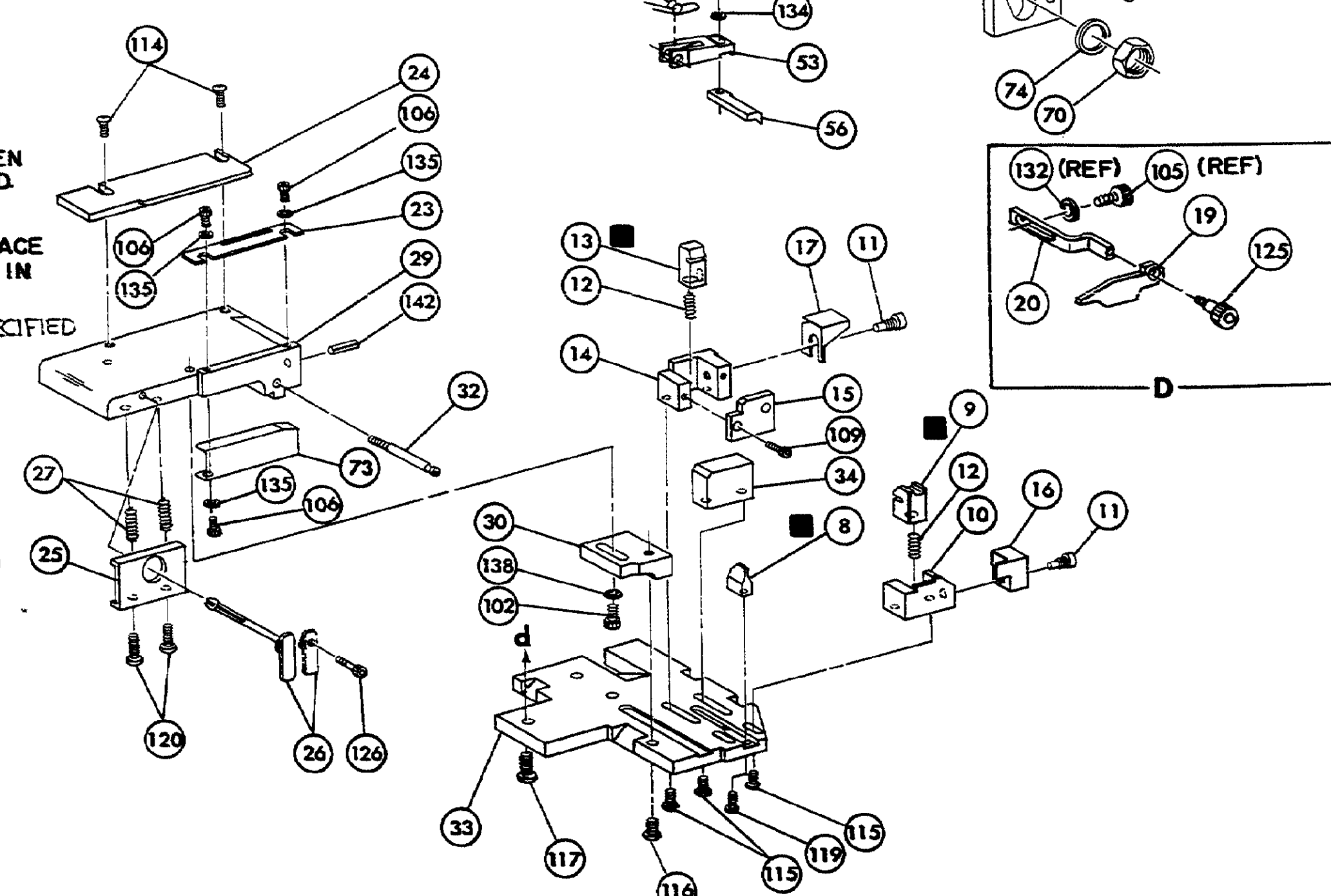

REF	21045-3	RING, RETAINING 'C' (.187 DIA) FEED FINGER PIN	145	REF	454220-1	CAP, HOUSING	59
			144	REF	454485-1	HOUSING	58
REF	5-21028-1	PIN, SLOT SPR (.125 DIA X .50) ADJ ROD	143				57
1	4-21028-0	PIN, SLOT SPR (.093 DIA X .75) STR G PLATE	142	1	690542-2	PAWL, FEED	56
REF	1-21030-1	PIN, DOWEL (.187 DIA X .50) LEVER	141	REF	240624-1	PIN, FEED FINGER	55
REF	1-21030-6	PIN, DOWEL (.187 DIA X 1.25) HOUSING	140	REF	691499-1	SPRING, FEED FINGER	54
	21024-5	WASHER, LOCK (NO 10) LUB ASSY	139	REF	690541-1	FINGER, FEED	53
1	21024-5	WASHER, LOCK (NO 10) STRIP GUIDE ADJ BLOCK	138	REF	455679-1	LEVER, TERMINAL FEED ARM	52
REF	21024-5	WASHER, LOCK (NO 10) ADJ PLATE	137		81 242-2	BUMPER, HOLDDOWN	51
REF	21024-5	WASHER, LOCK (NO 10) FEED GUIDE ROD	136		690753-1	SPACER, TONKER	50
2	21024-2	WASHER, LOCK (NO 4) FRONT STRIP GUIDE	135	1	7-21002-9	BOLT, CRIMPER	49
1	21024-4	WASHER, LOCK (NO 8) FEED FINGER	134	1	690602-5	CAM PRE-FEED 1-1/8 STROKE	48
2	21024-4	WASHER, LOCK (NO 8) DEPRESSOR	133				47
1	21024-4	WASHER, LOCK (NO 8) STRIPPER	132	1	459456-1	APPLICATOR, BASIC (SUB ASSY)	46
REF	21899-4	WASHER, FLAT (5/16 DIA) SCREW ADJ	131	1	690191-1	PLUG, NYLON	45
	21899-2	WASHER, FLAT (NO 10) LUB ASSY	130	1	455673-1	RAM	44
1	21018-5	NUT, HEX MACH (6-32) HOLDDOWN	129	1	690125-1	WASHER, LAMINATED	43
REF	21018-5	NUT, HEX MACH (6-32) FEED ADJ	128	1	690124-1	WASHER, RAM	42
			127			DISC, SPACER	41
	22353-8	SCR, SHLD. (.187 DIA X .250 LG) DRAG LEVER	126	2	23241-6	BALL, STEEL	40
1	456567-1	SCR, SHLD (.188 DIA X .125 LG) STRIPPER	125	2	690170-1	SPRING, COMPRESSION	39
1	21009-2	SCR, SKT SET (1/4-20 X .25) (LOC-WEL) RAM	124	1	690142-1	DISC, INSULATION	38
2	21017-2	SCR, DRIVE (NO 2 X .19)	123	1	4-690141-1	DISC, WIRE	37
REF	6-23715-5	SCR, RD HD MACH (6-32 X 1.50) FEED ADJ	122	1	22480-5	WASHER, SPRING	36
1	461264-1	PLATE, IDENTIFICATION	121	1	690212-1	POST, RAM	35
2	2-21002-9	SCR, BUT HD SKT CAP (10-32 X .75) DRAG	120	1	690780-6	SUPPORT, TERMINAL	34
1	22733-8	SCR, BUT HD SKT CAP (8-32 X .38) (LOC-WEL) ANVIL	119	REF	455675-1	PLATE, BASE	33
REF	2-21002-9	SCR, BUT HD SKT CAP (10-32 X .75) CAP	118	1	690432-3	SCREW, ADJUSTMENT	32
REF	17177-1	SCR, BUT HD SKT CAP (1/4-20 X .75) HOUSING	117				31
REF	2-21002-7	SCR, BUT HD SKT CAP (10-32 X .50) SG ADJ BLOCK	116	REF	455689-1	BLOCK, STRIP GUIDE ADJ	30
4	2-21002-2	SCR, BUT HD SKT CAP (8-32 X .50) SHEAR	115	1	455671-1	PLATE, STRIP GUIDE	29
2	2-21002-2	SCR, BUT HD SKT CAP (8-32 X .50) R STRIP GUIDE	114	1	1-455888-0	SPACER, FRONT SHEAR DEPRESSOR	28
			113	2	1-22284-1	SPRING, DRAG	27
1	1-21002-7	SCR, BUT HD SKT CAP (6-32 X .38) CAM	112	1	690546-1	LEVER, DRAG RELEASE	26
	3-21000-4	SCR, SKT HD CAP (10-32 X .38) LUBRICATOR ASSY	111	1	240792-1	DRAG, STOCK	25
2	23030-1	SCR, SKT HD CAP (6-32 X .25) (LOC-WEL) CP DISC	110	1	6-690504-4	GUIDE STRIP (REAR)	24
		SCR, SKT HD CAP (6-32 X .25) REAR SHEAR PLATE	109	1	690438-1	GUIDE, STRIP (FRONT)	23
2	1-21002-7	SCR, SKT HD CAP (8-32 X .50) DEPRESSOR	108				22
1	2-22603-0	SCR, HEX HD MACH (8-32 X .31) FEED FINGER	107	REF	4-22284-9	SPRING, FEED RETURN	21
2	1-21000-3	SCR, SKT HD CAP (4-40 X .25) F STRIP GUIDE	106	1	458950-1	ARM, STRIPPER	20
1	2-21000-7	SCR, SKT HD CAP (8-32 X .50) STRIPPER	105	1	458949-2	STRIPPER	19
REF	3-21000-7	SCR, SKT HD CAP (10-32 X .75) FEED ROD GUIDE	104		690786-6	HOLDER, TERMINAL	18
REF	3-21000-6	SCR, SKT HD CAP (10-32 X .62) FEED ADJ BLOCK	103			GUARD, CHIP (REAR)	17
1	3-21000-4	SCR, SKT HD CAP (10-32 X .38) SG ADJ BLOCK	102	1	691667-1	GUARD, CHIP (FRONT)	16
REF	3-21000-4	SCR, SKT HD CAP (10-32 X .38) PIVOT BLOCK	101			PLATE, SHEAR (REAR)	15
1	455755-1	GUARD ASSY	79			HOLDER, SHEAR (REAR)	14
1	1-465184-0	LUBRICATOR ASSY	78			SHEAR, FLOAT (REAR)	13
REF	852931-2	OIL, LUBRICATING	77	1	5-22280-0	SPRING, SHEAR	12
			76	1	690461-1	STOP, SHEAR	11
			75	1	690459-1	HOLDER, SHEAR (FRONT)	10
REF	458109-1	WASHER, SPECIAL	74	1	462006-2	SHEAR, FLOAT (FRONT)	9
	454877-3	PLATE, STRIP GUIDE COVER	73	1	3-458834-0	ANVIL	8
2	690603-1	SPRING, ASSIST	72			SPACER, DEPRESSOR (REAR)	7
REF	690517-1	SPACER	71			DEPRESSOR, SHEAR (REAR)	6
	22594-8	NUT, HEX	70	1	2-455889-0	DEPRESSOR, SHEAR (FRONT)	5
	240628-1	PLATE, ADJUSTMENT	69	1	238011-6	SPACER, TUBULAR, INS CRIMPER	4
	240626-1	SHAFT, PIVOT	68	1	5-456134-5	CRIMPER, INSULATION	3
	240633-1	BUSHING	67	1	1-455888-1	SPACER, CRIMPER	2
	455680-1	LEVER, INTERMEDIATE	66	1	456402-1	CRIMPER, WIRE	1
	240629-1	BLOCK, PIVOT	65				
	240632-2	SCREW, ADJUSTMENT FEED ROD	64				
	240659-3	PIN, CAM ROLLER	63				
	240658-1	ROLLER, CAM	62				
	454398-2	ROD, FEED	61				
REF	454178-1	GUIDE, FEED ROD	60				

CRIMPING DATA					APPLICATOR WILL APPLY	
PAD LTR	CRIMP HEIGHT	WIRE SIZE	WIRE STRIP LENGTH	ITEM NO		
A	.024	22 OR 24		66620		
B	NOT USED			86724		
C	NOT USED					
D	NOT USED					

CRIMP	SIZE	TYPE	FEED	APPL INST
WIRE	.055	F	390	A18040
INSUL	.062	F		

WIRE RANGE: 24-22 | INSULATION RANGE: .040-.050 | PRESS NO: 565435-5

REMARKS: AMP-O-LECTRIC PRE-FEED

APPL USED ON MACHINE PART NO	MACH SERIAL NO	DISTRIBUTION
CUSTOMER NAME	APPL SERIAL NO	ORIGINAL
ADDRESS	PURCHASE ORDER	CUSTOMER COPY
CITY	ENG APP	FIELD ENG COPY

REV	NO	REV
1	EC OISO-4655-93	458637-1 483
2	ECN A-351192	DR 2/7/86 APP 1/18/86
3	ECN A-324291	1/25/86
4	ECN R 7119	1/25/86
5	ECN R-6191	2/2/86

SET UP GAGE 10-1 | 458637-1 483 | NAME: MINIATURE QUICK CHANGE APPLICATOR | SIDE FEED (AMPLIMATE CONNECTOR)