

DRAWING MADE IN THIRD ANGLE PROJECTION

THIS DRAWING IS UNPUBLISHED. RELEASED FOR PUBLICATION

© COPYRIGHT 19 BY AMP INCORPORATED, HARRISBURG, PA. ALL INTERNATIONAL RIGHTS RESERVED. AMP PRODUCTS MAY BE COVERED BY U.S. AND FOREIGN PATENTS AND/OR PATENTS PENDING.

1 LOC CM DIST 53

REVISIONS					
P	ZONE	LTR	DESCRIPTION	DATE	APPROVED
✓		0	REL. NEW DRAWING TTI 81-101	1/11/83	PAS/SH
✓		A	REV PER ECN M-7384	9/13/83	TEB/SJ
✓		B	REV PER ECN AG 214	1/24/84	MC/KS
✓		B <sub>1</sub>	RESTORATION	7-85	KS/SJ
✓		C	ADDED -2 PER TTI CM85-74	3-19-85	CM/RS
✓		D	OBSOLETE -2 PER CM-947	7-14-87	PEC/TB
✓		E	REVISE PER CM-1511	2-9-88	PEC/RS
✓		F	REVISED PER CM-3328	2-20-91	PEC/RS
✓		G	REV PER ECN 0730-3928-92	1-7-93	WJG/RS
✓		H	REVISED PER EC 0730-4181-93	7-6-93	LWS/RS
		H1	REVISED PER ECR-19-018055	09JAN2020	PC/SF
		H2	REVISED PER ECR-21-118222	25JUL2022	AVN/VS

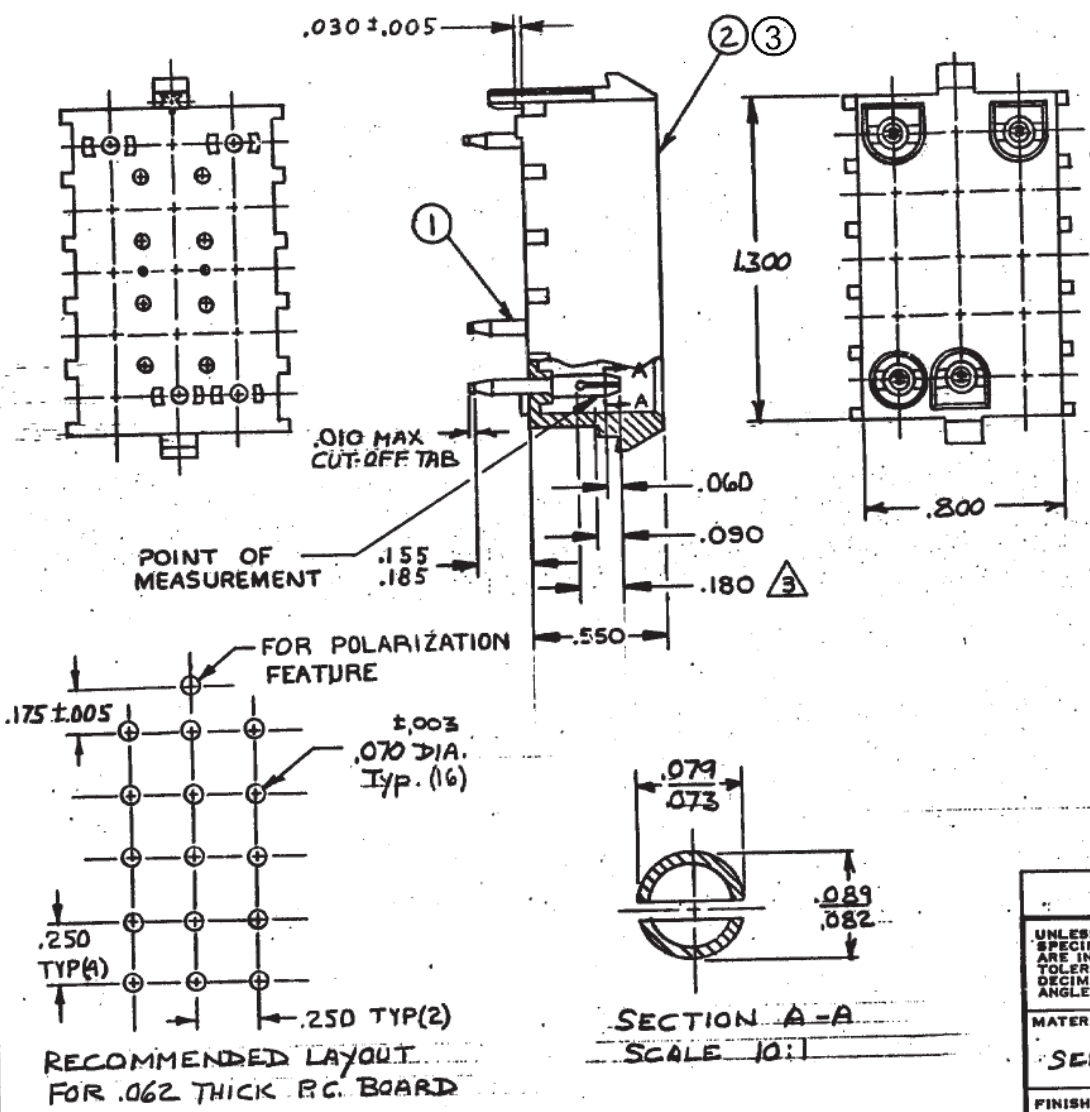

1. PARTS COMPLY WITH AMP SOLDERABILITY SPEC. 109-11-3
2. MATES WITH HOUSING No. 480710 USING SOCKET CONTACTS.
3. CONTACT IS PLATED OVERALL WITH .000050 NICKEL, THEN .000030 GOLD OVER CONTACT LENGTH INDICATED AND MATTE TIN ON SOLDER TAIL END.
4. PRELIMINARY PART.
5. DIMENSIONS SHOWN REPRESENT PRODUCT IN DRY CONDITION. ADDITIONAL 2% GROWTH DUE TO END USE LOCATION MOISTURE ABSORPTION MAY OCCUR AND SHOULD BE ACCOUNTED FOR.

No. PER ASSY	DESCRIPTION	MATERIAL & FINISH	ITEM No.	PART NO
1	HOUSING	NYLON, 94V-2, BLACK	3	1-641975-1
15	CONTACT	PHOS BRZ, PRE-TIN	1	4
1	HOUSING	NYLON, 94V-2, NATURAL	2	641975-1
15	CONTACT	PHOS BRZ, PRE-TIN	1	

UNLESS OTHERWISE SPECIFIED DIMENSIONS ARE IN INCHES. TOLERANCES ON: DECIMALS ± .015 ANGLES	CONTRACT NO	TE Connectivity	
	DR D.A. SALTZER 1-11-83	TE Connectivity	
MATERIAL	CHK D.S. Heide 2/14/83	NAME	
SEE TABLE	APPD B.F. Quill 2/14/83	HEADER ASSY, PIN, POLARIZED, UNIVERSAL MATE-N-LOK™ 15 CIRCUIT	
FINISH	DSGN APPD	SIZE B	FSCM NO 00779
SEE TABLE	OTHER APPD	DRAWING NO 641975	
		SCALE 2:1	SHEET