

THIS DRAWING IS UNPUBLISHED. RELEASED FOR PUBLICATION
 © COPYRIGHT BY TYCO ELECTRONICS CORPORATION. ALL RIGHTS RESERVED.

LOC		DIST		REVISIONS			
P	LTR	DESCRIPTION		DATE	DWN	APVD	
DF	A3	P					
		P		REV PER EC 0H14-0154-04	25JAN06	TK CT	

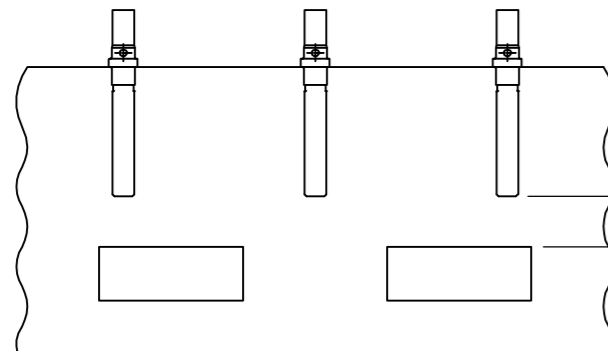

DETAIL A
TAPE MOUNTED
ASSEMBLY
(-4 ONLY)

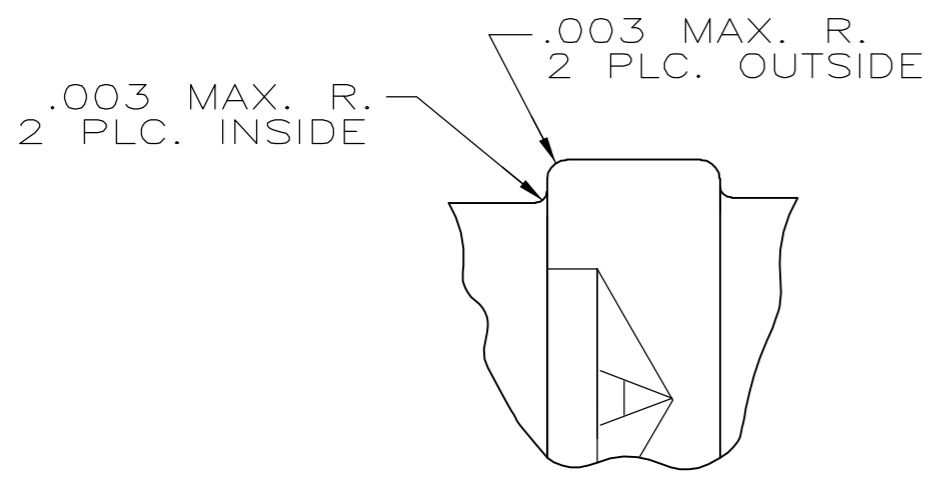
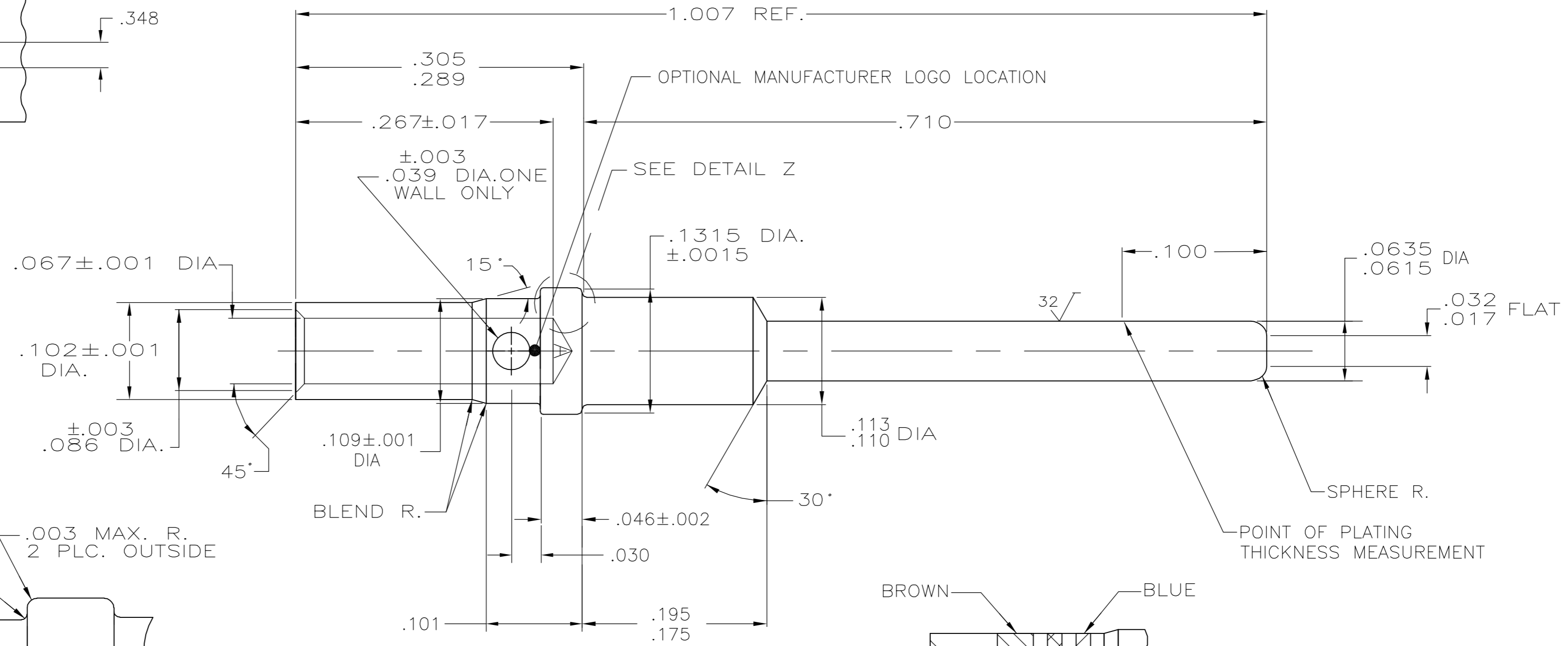

DETAIL Z
SCALE 20:1

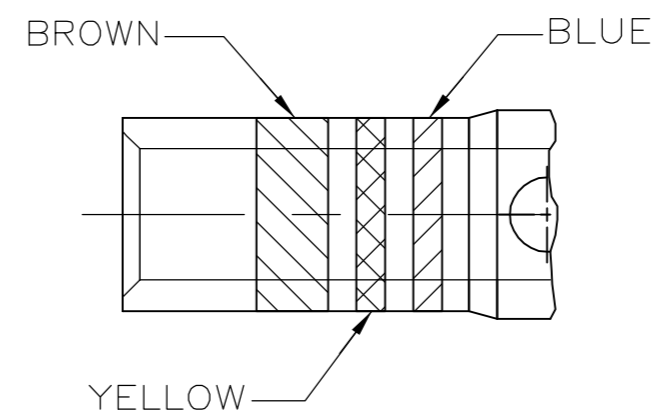

DETAIL

1. DIMENSIONS AFTER PLATING.

WHEN ORDERING CONTACT ON TAPE, ORDER BY THE TAPE NUMBER PLUS THE PACKAGING CODE AS FOLLOWS:

- FOR USE WITH AMP TAPETRONIC, PNEUMATIC TOOL-
A. 1000 PARTS TO A BOX. ADD PACKAGING CODE: 1MBOX
- FOR USE WITH 418 INDENT STRIPPER CRIMPER-
A. 1000 PARTS TO A BOX. ADD PACKAGING CODE: 1MBOX
B. 5000 PARTS TO A REEL. ADD PACKAGING CODE RMREEL

- 204978-2 1. SAME AS -1 EXCEPT:
2. FINISH: PLATED GOLD PER MIL-6-45204
OVERE NICKEL PER QQ-N-290
- 204978-3 1. AS SHOWN
- OBSOLETE 204978-4 1. SAME AS -3 EXCEPT:
2. MOUNTED ON MYLAR TAPE
- OBSOLETE 204978-5 1. SAME AS -3 EXCEPT:
2. GRAPHITE COATED
3. NO COLOR BANDS
- OBSOLETE 204978-6 1. SAME AS -3 EXCEPT:
2. COLOR CODE TO BE SINGLE BLUE BAND
- OBSOLETE 204978-8 1. SEE SHEET 2 OF 2

THIS DRAWING IS A CONTROLLED DOCUMENT.		DWN	J.LINDERMAN	2-10-93	 Tyco Electronics Corporation Harrisburg, PA 17105-3608
DIMENSIONS: INCHES		CHK	A.SHARPE	2-24-93	
TOLERANCES UNLESS OTHERWISE SPECIFIED:		APVD	A.SHARPE	2-24-93	
0 PLC ± - 1 PLC ± - 2 PLC ± .02 3 PLC ± .005 4 PLC ± - ANGLES ± - FINISH -		PRODUCT SPEC	-		
MATERIAL: SEE DASH NO.		APPLICATION SPEC	-		NAME: PIN CONTACT, SIZE 16, ARINC 600
		WEIGHT	-		SIZE: A2
		CUSTOMER DRAWING	SCALE: 10:1	SHEET: 1 of 1	RESTRICTED TO: -