

Tous droits strictement reserves. Reproduction ou communication a des tiers interdite sous quelque forme que ce soit sans autorisation écrite de FCI. Propriete de c FCI. Droits de reproduction FCI.

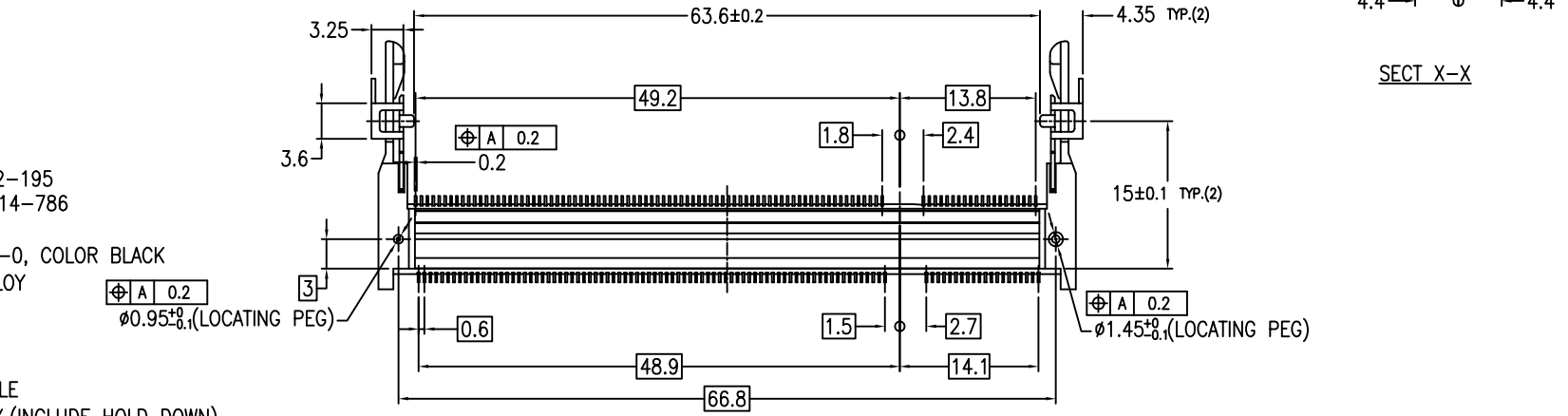

All rights strictly reserved. Reproduction or issue to third parties in any form whatever is not permitted without written authority from the proprietor of FCI. Copyright FCI.

PRODUCT NO.
10033853-*52**

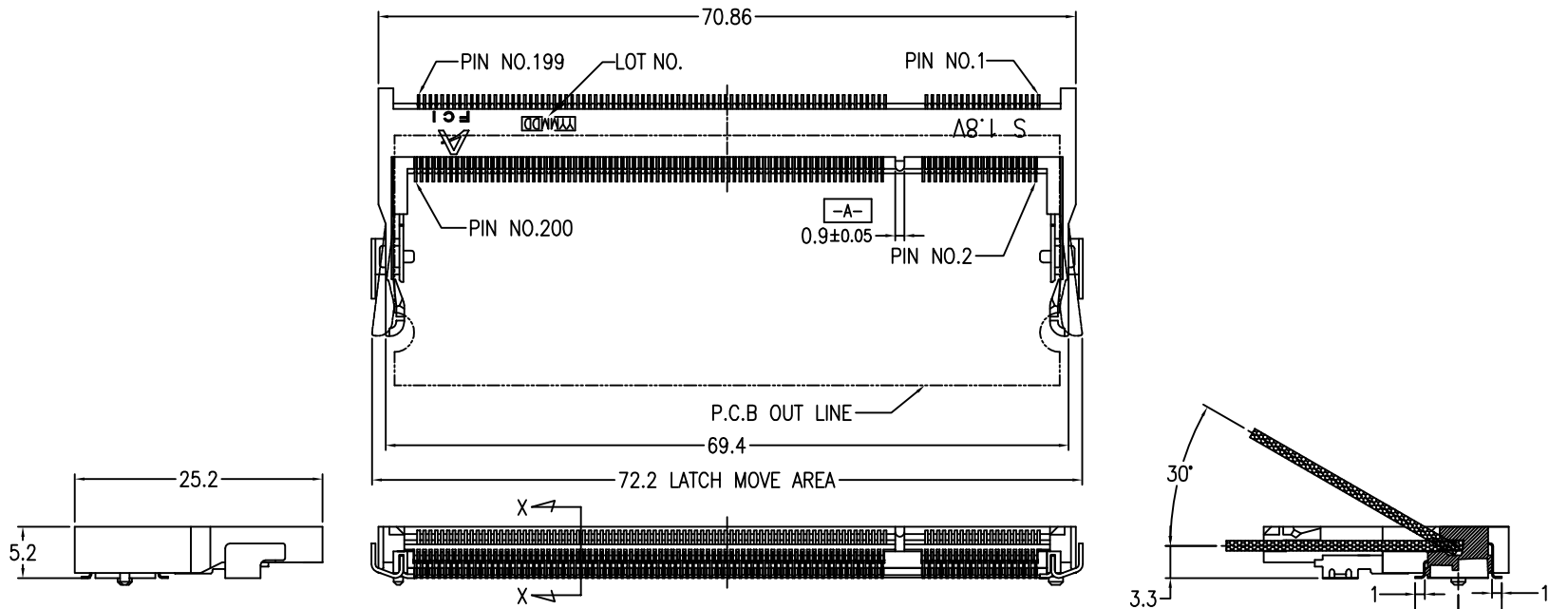

- NOTE
1. PRODUCT SPEC. : GS-12-195
 2. PACKAGING SPEC. : GS-14-786
 3. MATERIAL
 - 1) HOUSING : LCP, UL94V-0, COLOR BLACK
 - 2) CONTACT : COPPER ALLOY
 - 3) HOLD DOWN : BRASS
 4. FINISH
 - 1) TERMINAL : SEE TABLE
 - 2) HOLD DOWN : SEE TABLE
 5. CO-PLANARITY : 0.1 MAX.(INCLUDE HOLD DOWN)
 6. THIS PRODUCT MEETS EUROPEAN UNION DIRECTIVES AND OTHER COUNTRY REGULATIONS AS DESCRIBED IN GS-22-008.
 7. THE HOUSING WILL WITHSTAND EXPOSURE TO 260° PEAK TEMPERATURE FOR 10 SECONDS IN A REFLOW SOLDER APPLICATION.

mat'l. code				tolerances unless otherwise specified			CUSTOMER COPY	 www.fciconnect.com
ltr	ecn no	dr	date		.X ± 0.20	projection		
2		M H	8/28/'03	linear	.XX ± 0.10			DDR II 0.6 mm PITCH 200 POS. STANDARD TYPE ASS'Y
3		M H	4/2/'04					
4		M H	6/29/'04	angles	0° ± 5°		scale 2:1	B 10033853 sheet 1 of 4
A	J04-0401	M H	9/28/'04	dr	M.Hasegawa 6/29/'04	MM		
B	T05-0022	R C	11/9/'04	enrg	M.Hasegawa 6/29/'04		sheet 1 of 4	
C	T05-0229	R C	10/12/'05	chr				
D	PG08-0333	B L	12/1/'08	appd				
sheet index	revision	D	D	D	D			
	sheet	1	2	3	4			

PRODUCT NO.

10033853-*52**

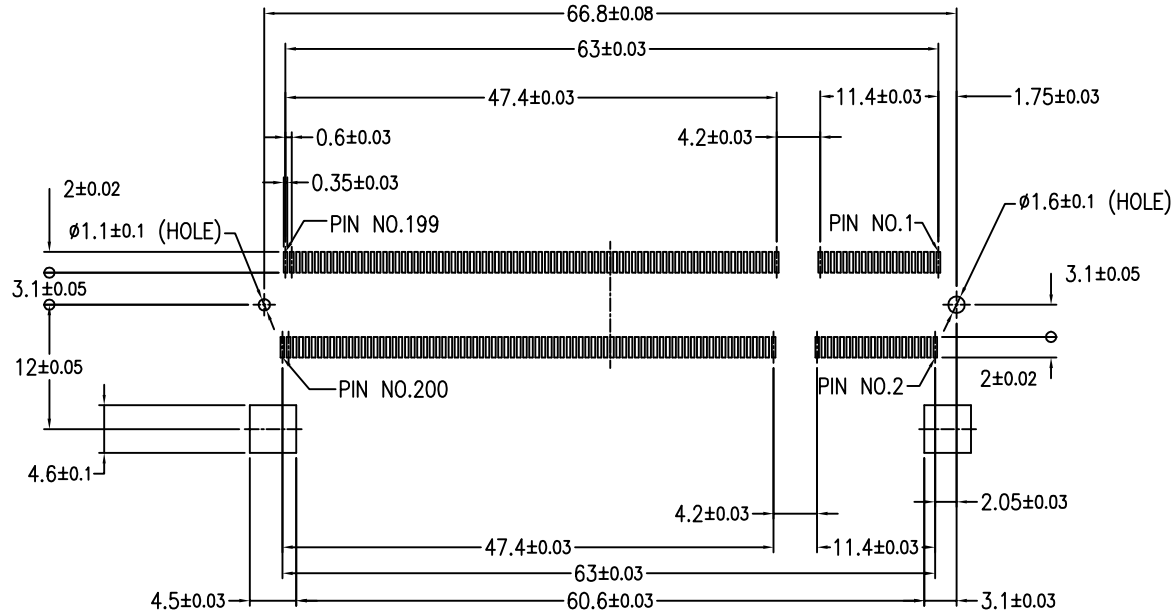

RECOMMENDED MOUNTING P.C.B LAYOUT

Tous droits strictement reserves. Reproduction ou communication a des tiers interdite sous quelque forme que ce soit sans autorisation écrite de FCI. Propriete de c FCI. Droits de reproduction FCI.



All rights strictly reserved. Reproduction or issue to third parties in any form whatever is not permitted without written authority from the proprietor. Property of FCI. Copyright FCI.

mat'l. code				tolerances unless otherwise specified			CUSTOMER COPY	 www.fciconnect.com
ltr	ecn no	dr	date	linear	.X ± 0.20	projection		
D					.XX ± 0.10		 MM	DDR II 0.6 mm PITCH 200 POS. STANDARD TYPE ASS'Y
				angles	0° ±5°	scale		
				dr	M.Hasegawa 6/29/04		2:1	code JP
				enr	M.Hasegawa 6/29/04	size dwg no		
				chr			B	10033853
				appd				
sheet index	revision sheet							

Tous droits strictement reserves. Reproduction ou communication a des tiers interdite sous quelque forme que ce soit sans autorisation ecrite de FCI. Propriete de c FCI. Droits de reproduction FCI.



All rights strictly reserved. Reproduction or issue to third parties in any form whatever is not permitted without written authority from the proprietor. Property of FCI. Copyright FCI.

PRODUCT NO.
10033853-*52**

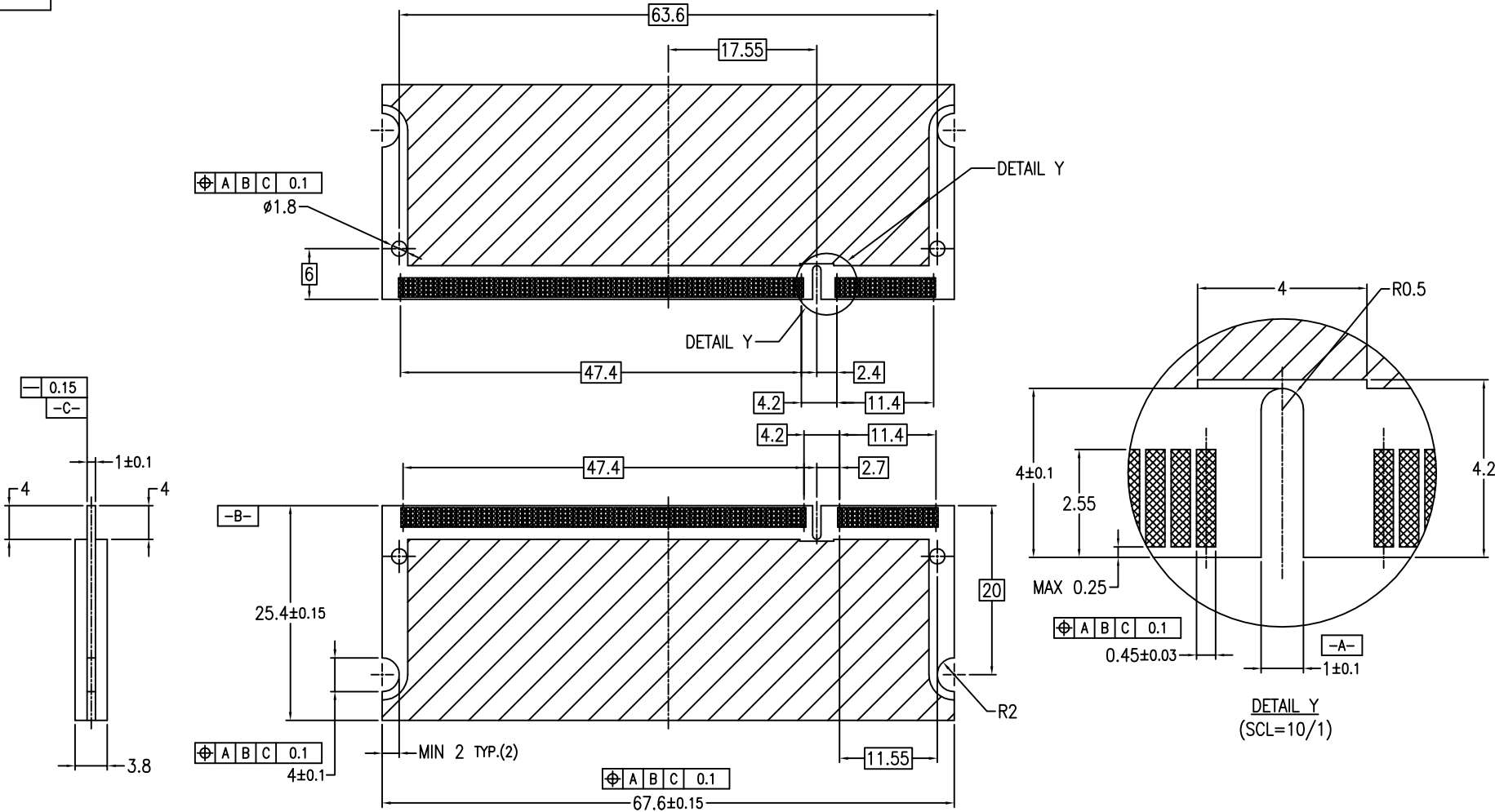

RECOMMENDED MODULE P.C.B. LAYOUT

mat'l. code				tolerances unless otherwise specified		CUSTOMER COPY	www.fciconnect.com
ltr	ecn no	dr	date	linear	.X ± 0.20 .XX ± 0.10		
D				angles	0° ±5°		DDR II 0.6 mm PITCH 200 POS. STANDARD TYPE ASS'Y
				dr	M.Hasegawa 6/29/04		MM
				enr	M.Hasegawa 6/29/04	scale	size dwg no
				chr		2:1	B 10033853
				appd			code JP
sheet index	revision sheet						sheet 3 of

Tous droits strictement réservés. Reproduction ou communication a des tiers interdite sous quelque forme que ce soit sans autorisation écrite@fcjconnect.com. Propriété de c FCI. Droits de reproduction FCI.



All rights strictly reserved. Reproduction or issue to third parties in any form whatever is not permitted without written authority from the proprietor. Property of FCI. Copyright FCI.

PRODUCT NO.	LOCATING PEG	TERMINAL CONTACT AREA FINISH	HOLD DOWN FINISH	SOLDER TAIL FINISH
10033853-052FSLF	YES	Au FLASH	PURE Sn PLATING	Au FLASH
10033853-152FSLF	NO			
10033853-052TSLF	YES	Au 0.3um MIN.		
10033853-152TSLF	NO			
10033853-052ASLF	YES	Au 0.76um MIN.		
10033853-152ASLF	NO			
10033853-052FB	YES	Au FLASH	Sn-Pb PLATING	Au FLASH
10033853-152FB	NO			
10033853-052TB	YES	Au 0.3um MIN.		
10033853-152TB	NO			
10033853-052AB	YES	Au 0.76um MIN.		
10033853-152AB	NO			
10033853-252FSLF	YES	Au FLASH	PURE Sn PLATING	Pure Sn PLATING
10033853-352FSLF	NO			
10033853-252TSLF	YES	Au 0.3um MIN.		
10033853-352TSLF	NO			
10033853-252ASLF	YES	Au 0.76um MIN.		
10033853-352ASLF	NO			
10033853-252FB	YES	Au FLASH	Sn-Pb PLATING	Pure Sn PLATING
10033853-352FB	NO			
10033853-252TB	YES	Au 0.3um MIN.		
10033853-352TB	NO			
10033853-252AB	YES	Au 0.76um MIN.		
10033853-352AB	NO			
10033853-452FS	YES	Au FLASH	PURE Sn PLATING	Sn-Pb PLATING
10033853-552FS	NO			
10033853-452TS	YES	Au 0.3um MIN.		
10033853-552TS	NO			
10033853-452AS	YES	Au 0.76um MIN.		
10033853-552AS	NO			
10033853-452FB	YES	Au FLASH	Sn-Pb PLATING	Sn-Pb PLATING
10033853-552FB	NO			
10033853-452TB	YES	Au 0.3um MIN.		
10033853-552TB	NO			
10033853-452AB	YES	Au 0.76um MIN.		
10033853-552AB	NO			

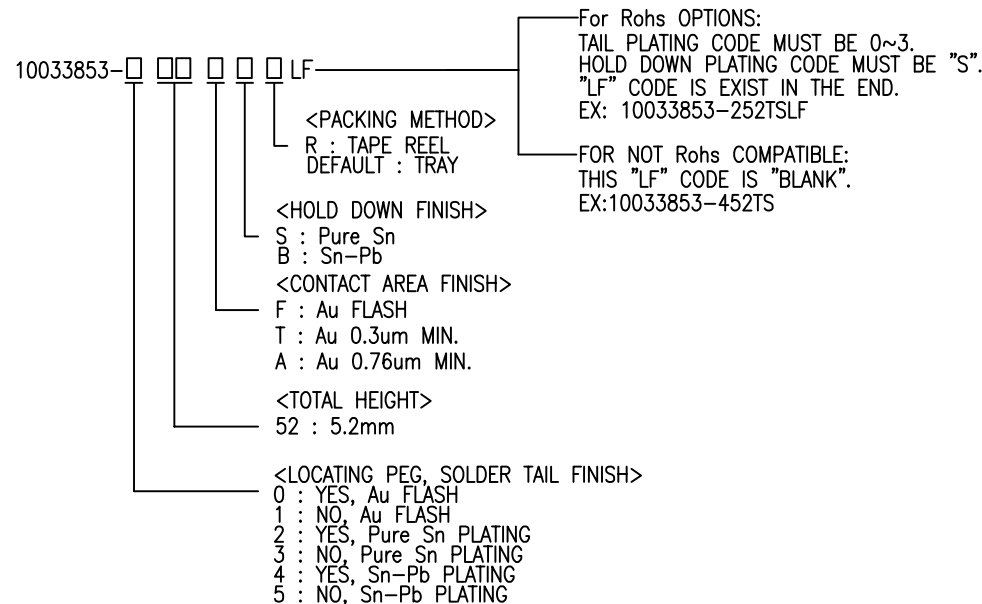

mat'l. code				tolerances unless otherwise specified			CUSTOMER COPY		 www.fciconnect.com	
ltr	ecn no	dr	date	linear	.X ± 0.20		projection	title		
D					.XX ± 0.10			DDR II 0.6 mm PITCH 200 POS. STANDARD TYPE ASS'Y		
				angles	0° ±5°		 MM	product family 50UF SO-DIMM		code
				dr	M.Hasegawa	6/29/04		scale	size/dwg no	
				enr	M.Hasegawa	6/29/04	2:1		B 10033853	
				chr						
				appd						
sheet index	revision sheet									