

PART NUMBER	REVISION	DESCRIPTION	FEED TYPE
2151809-2	F	FINE CRIMP HEIGHT ADJUST	PNEUMATIC
7-2151809-2	F	PNEUMATIC AND CRIMP TOOLING KIT	PNEUMATIC
7-2151809-7	A	CRIMP TOOLING KIT	-

ATLANTIC VERSION TERMINATOR INTERFACE ADAPTER

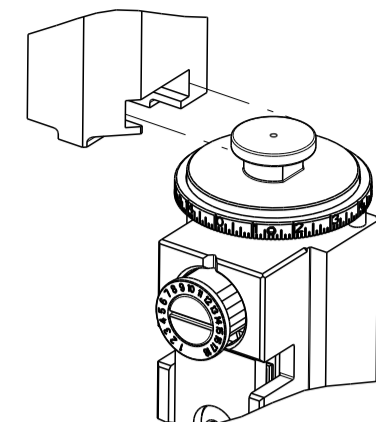

APPLICATOR DATA		
CRIMP	SIZE	TYPE
WIRE	4.06 mm [1.60]	F
INSUL	-	-

APPLICATOR INSTRUCTIONS
408-35042

TERMINAL DATA: MULTI-CONTACT TERMINAL		TE CRIMP SPECIFICATION	
TERMINAL NAME: TERMINAL			
WIRE STRIP LENGTH		INSULATION DIAMETER RANGE	
4.58-4.96 mm [1.80-.195 IN]		∅ -	
TERMINAL APPLICATION SPECIFICATION	NONE		
TERMINALS APPLIED			
TE TERMINAL	MULTI-CONTACT TERMINAL	TE TERMINAL	MULTI-CONTACT TERMINAL
1949881-1	32.0016P2000-UR	1949880-1	32.0017P2000-UR

WIRE SIZE	CRIMP HEIGHT mm [INCH]	CRIMP HEIGHT REFERENCE SETTING
6.00mm2	2.56 +/- 0.05 [1.01 +/- .002]	4.3
10 AWG	2.38 +/- 0.05 [1.09 +/- .002]	6.0
4.00mm2	2.17 +/- 0.05 [1.085 +/- .002]	8.2

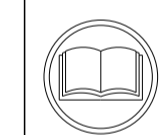

- RECOMMENDED SPARE PARTS
- REFER TO SUPPLIED INSTRUCTION SHEET FOR CLEANING, LUBRICATION AND STORAGE OF APPLICATOR.
- CRIMP HEIGHT REFERENCE SETTING WAS THE SETTING USED WHEN THE APPLICATOR WAS QUALIFIED AT THE FACTORY. ADJUSTMENT MAY BE NECESSARY WHEN RUNNING APPLICATOR IN THE FIELD.
- UNLESS SPECIFIED OTHERWISE TORQUE VALUES SHALL BE USED PER DOCUMENT, 101-35000.
- TERMINAL PITCH NOT COMPATIBLE WITH MECHANICAL FEED.
- TERMINAL LUBRICANT IS RECOMMENDED.

***WARNING**
ON INSTALLATION, SET WIRE DISC TO CRIMP HEIGHT REFERENCE SETTING FOR LARGEST WIRE SIZE. CRIMP HEIGHT REFERENCE SETTINGS GREATER THAN THE VALUE SHOWN MAY CAUSE DAMAGE TO THE CRIMP TOOLING, REFER TO THE INSTRUCTION SHEET FOR PROPER SETUP AND ADJUSTMENTS.

LOC	DIST	REVISIONS					
A	66	P	LTN	DESCRIPTION	DATE	OWN	APVD
		C		ECR-16-004766	01APR2016	XZ	CT
		D		ECR-18-020117	29DEC2018	FL	CT
		E		ECR-19-001518	29JAN2019	MEH	CT
		F		ECR-19-009769	23JUN2019	TB	TE

-	2	2	2168083-1	SCR, SKT HD CAP, RoHS, M3 X 8.0	269
-	1	1	1633782-2	FENCE	267
-	1	1	2119641-1	FEED CAM, AIR FEED	248
-	1	1	7-18023-7	SCR, SKT HD CAP M3 X 4.0	241
-	1	1	2844940-1	AIR FEED MODULE	238
-	REF	REF	994970-2	COUNTER, MAGNETIC	164
-	1	1	1-22281-8	SPRING, COMPRESSION	121
-	1	1	2119955-1	ASSY, LUBRICATOR, SIDE FEED	113
-	1	1	2844908-1	SCREW, LOCKING	99
-	1	1	2844907-1	POST, LOCKING	98
-	1	1	1-690438-0	FRONT STRIP GUIDE	96
-	2	2	2168083-1	SCR, SKT HD CAP, RoHS, M3 X 8.0	95
-	1	1	2168083-6	SCR, SKT HD CAP, RoHS, M5 X 65	93
-	1	1	455888-3	SPACER, CRIMPER	82
-	2	2	2079383-4	SCR, BHSC, RoHS (M4 X 8)	79
-	1	1	1803096-1	EXTENSION PLATE	78
-	1	1	1803607-3	DOCUMENTATION PACKAGE	71
-	1	1	2119740-1	TAG, IDENTIFICATION	67
-	2	2	2168078-1	SCREW, DRIVE, RH, RoHS, 2 x .188	66
-	2	2	2-18032-5	SCR, SET, FLT PNT, M5 X 20.0	61
-	1	1	2168083-2	SCR, SKT HD CAP, RoHS, M4 X 8.0	60
-	1	1	5-18022-5	SCR, HEX HD CAP, M4 X 6.0	59
-	1	1	1338685-1	PAWL, FEED	56
-	4	4	2168083-3	SCR, SKT HD CAP, RoHS, M4 X 12.0	54
-	2	2	1-2168083-0	SCR, SKT HD CAP, RoHS, M4 X 10	53
-	1	1	5018030-1	NUT, HEX, REG, RoHS, M3	52
-	1	1	811242-6	BUMPER, HOLD DOWN	51
-	1	1	690753-2	SPACER, TONKER	50
-	1	1	18023-9	SCR, SKT HD CAP M4 X 6.0	49
-	1	1	1803583-9	APPLICATOR BASIC ASSEMBLY, SF	46
-	1	1	1803515-1	RAM ASSEMBLY, SF ATLANTIC	44
-	1	1	1803602-1	SCR, BHSC, RoHS (M8 X 25)	41
-	1	1	1752356-4	SUPPORT, TERMINAL	34
-	2	2	2079383-5	SCR, BHSC, RoHS (M4 X 20)	33
-	2	2	2-2844962-1	SPACER, CYLINDRICAL, STRIP GUIDE	30
-	1	1	2844938-1	PLATE, STRIP GUIDE	29
-	1	1	1-455888-0	SPACER, CRIMPER	28
-	2	2	22281-8	SPRING, COMPRESSION	27
-	1	1	356835-1	LEVER, DRAG RELEASE	26
-	1	1	240792-1	DRAG, TERMINAL	25
-	1	1	1320928-4	STRIP GUIDE	24
-	1	1	980371-4	SCR, SKT HD SHLDR 5.0 DIA X 6.0	23
-	1	1	2168083-2	SCR, SKT HD CAP, RoHS, M4 X 8.0	21
-	2	2	1-18028-2	WASHER, FLAT, REG M4	20
-	1	1	2119533-1	STRIPPER, SIDE FEED	19
-	1	1	2119806-1	INSERT, SHEAR	13
-	1	1	3-22280-3	SPRING, COMPRESSION	12
-	1	1	1-356885-3	STOP, SHEAR	11
-	1	1	2119805-1	SHEAR HOLDER, FRONT	10
-	1	1	318707-4	FLOATING SHEAR, FRONT	9
-	1	2	1-1633933-4	ANVIL, COMBINATION	8
-	-	-	-	-	7
-	-	-	-	-	6
-	1	1	1-2119757-0	DEPRESSOR, SHEAR	5
-	-	-	-	-	4
-	-	-	-	-	3
-	-	-	-	-	2
-	1	2	1-456414-1	CRIMPER, WIRE	1

ATLANTIC VERSION
Shown on sheets 1 of 4 & 2 of 4
(Pacific version shown on sheets 3 of 4 & 4 of 4)

DIMENSIONS:		TOLERANCES UNLESS OTHERWISE SPECIFIED:		DRAWING NO		RESTRICTED TO	
mm	0 PLC ±	1 PLC ±	2 PLC ±	3 PLC ±	4 PLC ±	ANGLES ±	FINISH ±
MATERIAL				WEIGHT	SCALE	SHEET	REV
Customer Accessible Production Drawing				00779	1:1	1 of 4	F

LOC	DIST	REVISIONS					
		P	LTN	DESCRIPTION	DATE	DWN	APVD
A	66	-	-	SEE SHEET 1	-	-	-

FEED TYPE

PNEUMATIC

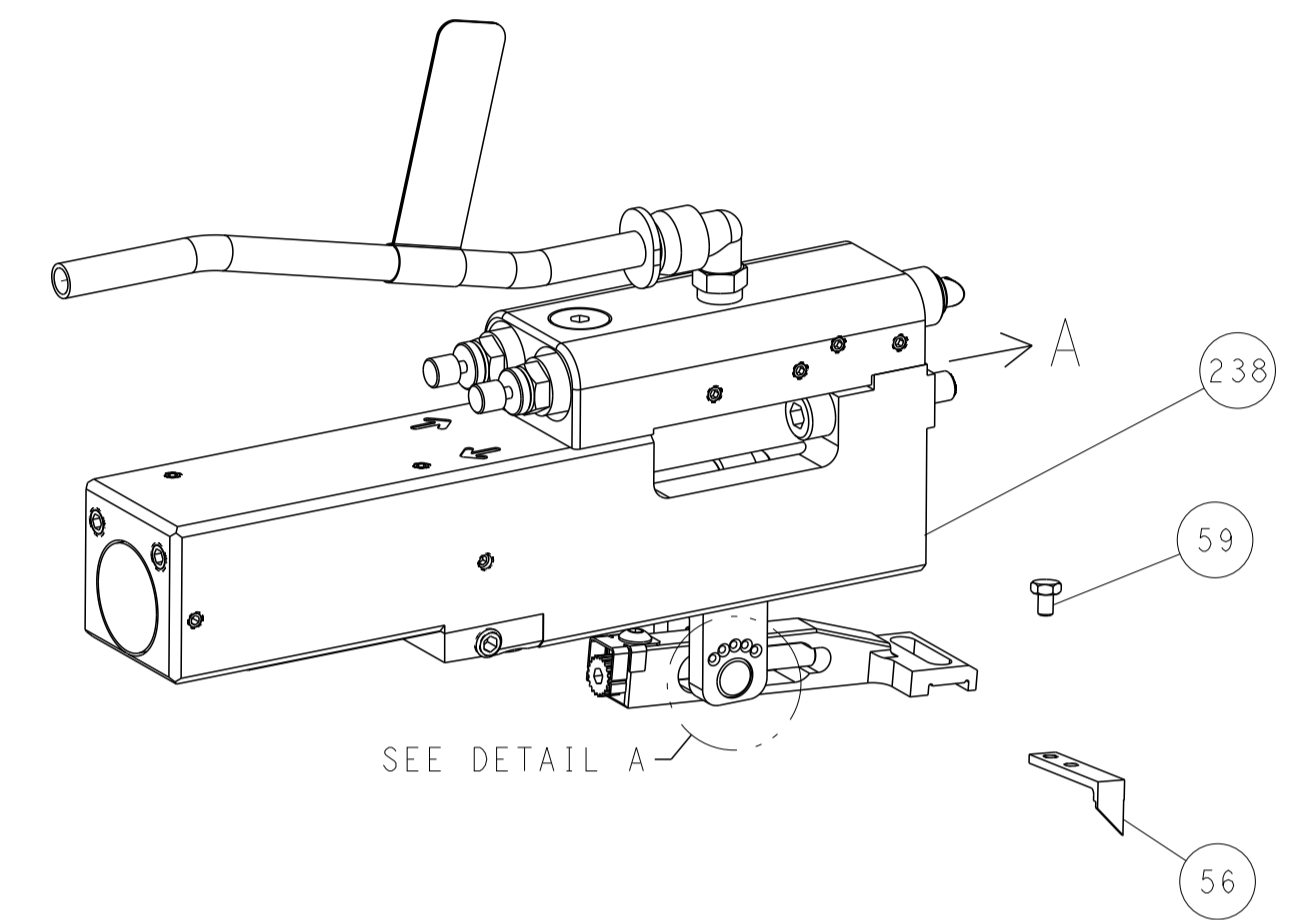

FEED SPRING SETTING POSITION (SHOWN FROM REAR SIDE)

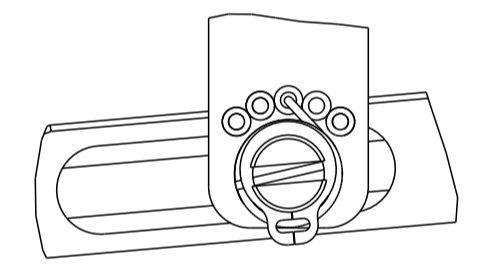

DETAIL A

CAM POSITION

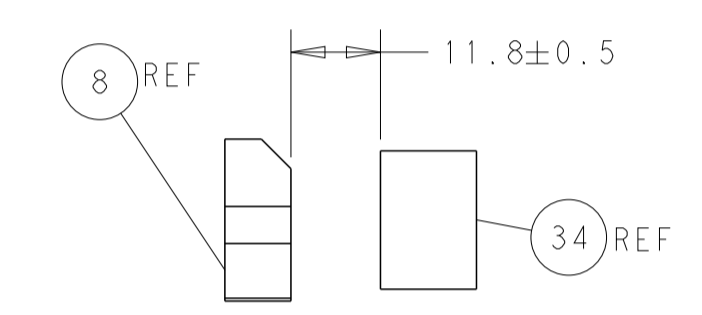
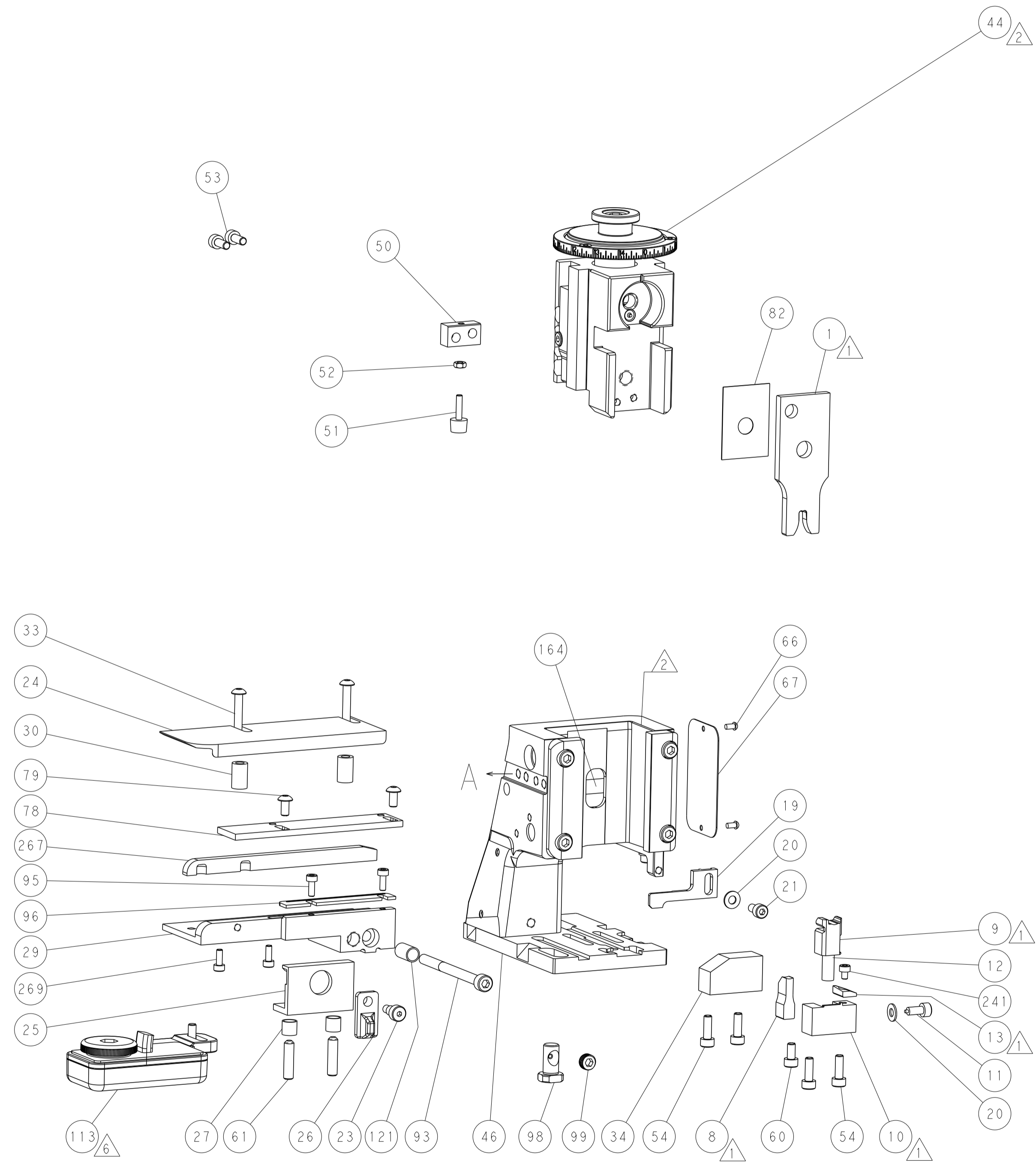
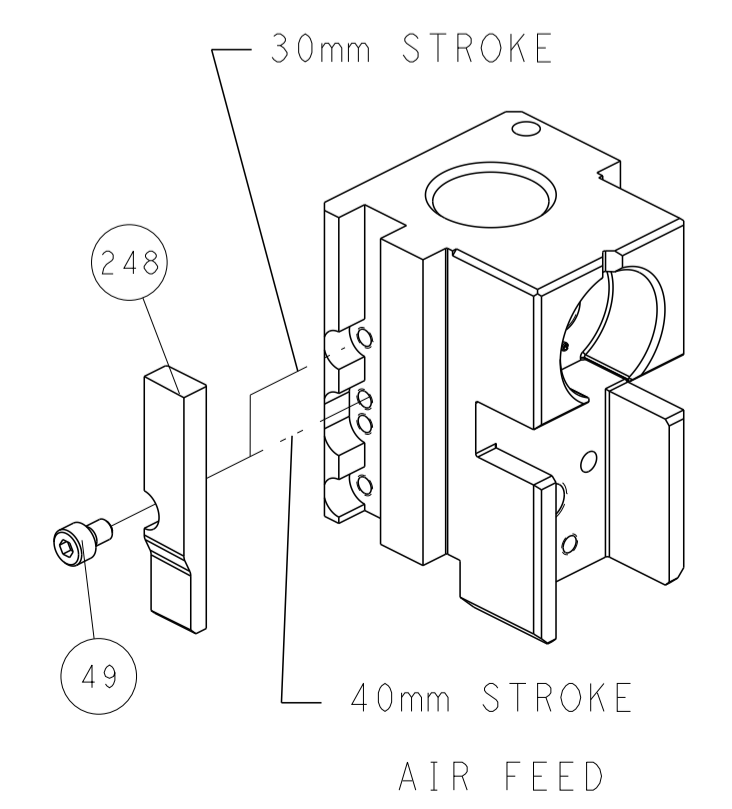

TERMINAL SUPPORT LOCATION

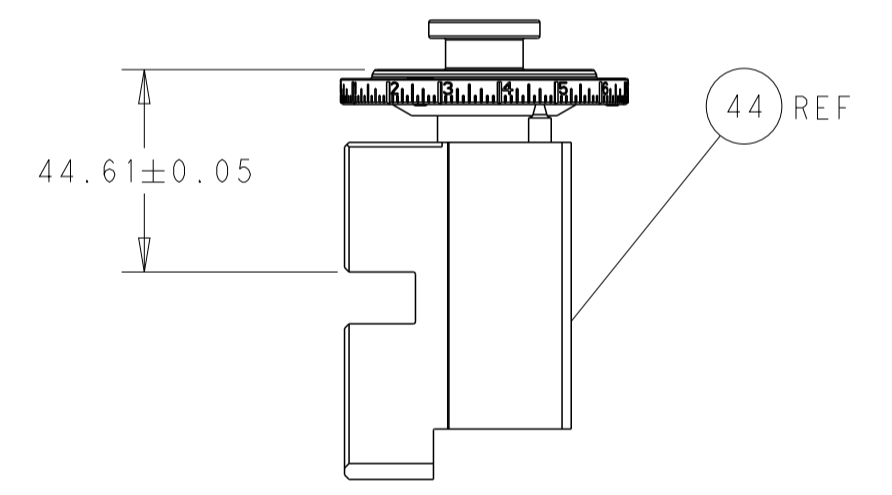

RAM SET-UP

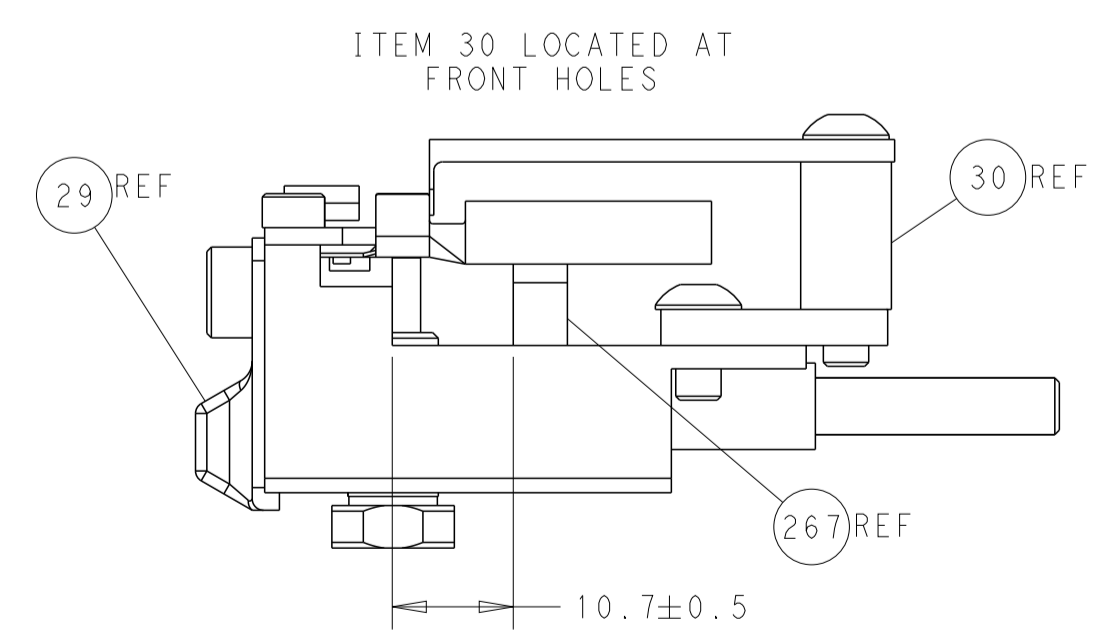

FEED TRACK POSITION GUIDE BY WIRE BARREL

ATLANTIC VERSION
 Shown on sheets 1 of 4 & 2 of 4
 (Pacific version shown on sheets 3 of 4 & 4 of 4)

<small>THIS DRAWING IS UNPUBLISHED. RELEASED FOR PUBLICATION BY TYCO ELECTRONICS CORPORATION. ALL RIGHTS RESERVED.</small>		DWN: H. HUANG 28NOV2012 CHK: S. XI 28NOV2012 APVD: S. XI 28NOV2012	TE Connectivity Harrisburg, PA 17105-3608
DIMENSIONS: mm TOLERANCES UNLESS OTHERWISE SPECIFIED: 0 PLC ± 1 PLC ± 2 PLC ± 3 PLC ± 4 PLC ± ANGLES ± FINISH ±		NAME: Ocean Side Feed Applicator PRODUCT SPEC: APPLICATION SPEC: SIZE: A1 CAGE CODE: 00779 DRAWING NO: 2151809	RESTRICTED TO: F
MATERIAL:		WEIGHT:	SCALE: 1:2 SHEET: 2 OF 4 REV: F

THIS DRAWING IS UNPUBLISHED.	RELEASED FOR PUBLICATION		
COPYRIGHT 20 BY TYCO ELECTRONICS CORPORATION. ALL RIGHTS RESERVED.			
PART NUMBER	REVISION	DESCRIPTION	FEED TYPE
2-2151809-2	F	FINE CRIMP HEIGHT ADJUST	PNEUMATIC
7-2151809-7	A	CRIMP TOOLING KIT	-

PACIFIC VERSION TERMINATOR
INTERFACE ADAPTER



APPLICATOR DATA		
CRIMP	SIZE	TYPE
WIRE	4.06 mm [1.60]	F
INSUL	-	-
APPLICATOR INSTRUCTIONS 408-35042		

TERMINAL DATA: MULTI-CONTACT TERMINAL TE CRIMP SPECIFICATION	
TERMINAL NAME: TERMINAL	
WIRE STRIP LENGTH 4.58-4.96 mm [1.80-.195 IN]	INSULATION DIAMETER RANGE Ø -
TERMINAL APPLICATION SPECIFICATION NONE	-
TERMINALS APPLIED	
TE TERMINAL 1949881-1	MULTI-CONTACT TERMINAL 32.0016P2000-UR
TE TERMINAL 1949880-1	MULTI-CONTACT TERMINAL 32.0017P2000-UR

WIRE SIZE	CRIMP HEIGHT mm [INCH]	CRIMP HEIGHT REFERENCE SETTING
6.00mm2	2.56+/-0.05 [1.01+/-0.02]	4.3
10 AWG	2.38+/-0.05 [1.094+/-0.02]	6.0
4.00mm2	2.17+/-0.05 [1.085+/-0.02]	8.2



- 1 RECOMMENDED SPARE PARTS
- 2 REFER TO SUPPLIED INSTRUCTION SHEET FOR CLEANING, LUBRICATION AND STORAGE OF APPLICATOR.
- 3 CRIMP HEIGHT REFERENCE SETTING WAS THE SETTING USED WHEN THE APPLICATOR WAS QUALIFIED AT THE FACTORY. ADJUSTMENT MAY BE NECESSARY WHEN RUNNING APPLICATOR IN THE FIELD.
- 4. UNLESS SPECIFIED OTHERWISE TORQUE VALUES SHALL BE USED PER DOCUMENT, 101-35000.
- 5 TERMINAL PITCH NOT COMPATIBLE WITH MECHANICAL FEED.
- 6 TERMINAL LUBRICANT IS RECOMMENDED.

***WARNING**
ON INSTALLATION, SET WIRE DISC TO CRIMP HEIGHT REFERENCE SETTING FOR LARGEST WIRE SIZE. CRIMP HEIGHT REFERENCE SETTINGS GREATER THAN THE VALUE SHOWN MAY CAUSE DAMAGE TO THE CRIMP TOOLING, REFER TO THE INSTRUCTION SHEET FOR PROPER SETUP AND ADJUSTMENTS.

LOC	DIST	REV	DATE	BY	APPD
A	66	-	-	-	-

REV	DATE	BY	APPD	DESCRIPTION	DATE	BY	APPD
-	2	2168083-1	SCR, SKT HD CAP, RoHS, M3 X 8.0	269			
-	1	1633782-2	FENCE	267			
-	1	7-18023-7	SCR, SKT HD CAP M3 X 4.0	241			
-	1	2844940-1	AIR FEED MODULE	238			
-	REF	994970-2	COUNTER, MAGNETIC	164			
-	1	2119641-2	FEED CAM, AIR FEED	151			
-	1	2168083-8	SCR, SKT HD CAP, RoHS, M4 X 16	144			
-	4	2168083-9	SCR, SKT HD CAP, RoHS, M4 X 20	143			
-	1	1-1803583-0	APPLICATOR BASIC ASSEMBLY, SF	141			
-	1	1803516-1	RAM ASSEMBLY, SF PACIFIC	140			
-	1	1-22281-8	SPRING, COMPRESSION	121			
-	1	2119955-1	ASSY, LUBRICATOR, SIDE FEED	113			
-	1	2844908-1	SCREW, LOCKING	99			
-	1	2844907-1	POST, LOCKING	98			
-	1	1-690438-0	FRONT STRIP GUIDE	96			
-	2	2168083-1	SCR, SKT HD CAP, RoHS, M3 X 8.0	95			
-	1	2168083-6	SCR, SKT HD CAP, RoHS, M5 X 65	93			
-	1	455888-3	SPACER, CRIMPER	82			
-	2	2079383-4	SCR, BHSC, RoHS (M4 X 8)	79			
-	1	1803096-1	EXTENSION PLATE	78			
-	1	1803607-3	DOCUMENTATION PACKAGE	71			
-	1	2119740-1	TAG IDENTIFICATION	67			
-	2	2168078-1	SCREW, DRIVE, RH, RoHS, 2 x .188	66			
-	2	2-18032-5	SCR, SET, FLT PNT, M5 X 20.0	61			
-	1	5-18022-5	SCR, HEX HD CAP, M4 X 6.0	59			
-	1	1338685-1	PAWL, FEED	56			
-	2	1-2168083-0	SCR, SKT HD CAP, RoHS, M4 X 10	53			
-	1	5018030-1	NUT, HEX, REG, RoHS, M3	52			
-	1	811242-6	BUMPER, HOLD DOWN	51			
-	1	690753-2	SPACER, TONKER	50			
-	1	18023-9	SCR, SKT HD CAP M4 X 6.0	49			
-	1	1803602-1	SCR, BHSC, RoHS (M8 X 25)	41			
-	1	1752356-4	SUPPORT, TERMINAL	34			
-	2	2079383-5	SCR, BHSC, RoHS (M4 X 20)	33			
-	2	2-2844962-1	SPACER, CYLINDRICAL, STRIP GUIDE	30			
-	1	2844938-1	PLATE, STRIP GUIDE	29			
-	1	1-455888-0	SPACER, CRIMPER	28			
-	2	22281-8	SPRING, COMPRESSION	27			
-	1	356835-1	LEVER, DRAG RELEASE	26			
-	1	240792-1	DRAG, TERMINAL	25			
-	1	1320928-4	STRIP GUIDE	24			
-	1	980371-4	SCR, SKT HD SHLDR 5.0 DIA X 6.0	23			
-	1	2168083-2	SCR, SKT HD CAP, RoHS, M4 X 8.0	21			
-	2	1-18028-2	WASHER, FLAT, REG M4	20			
-	1	2119533-1	STRIPPER, SIDE FEED	19			
-	1	2119806-1	INSERT, SHEAR	13			
-	1	3-22280-3	SPRING, COMPRESSION	12			
-	1	1-356885-3	STOP, SHEAR	11			
-	1	2119805-1	SHEAR HOLDER, FRONT	10			
-	1	318707-4	FLOATING SHEAR, FRONT	9			
-	1	1-1633933-4	ANVIL, COMBINATION	8			
-	-	-	-	7			
-	-	-	-	6			
-	1	1-2119757-0	DEPRESSOR, SHEAR	5			
-	-	-	-	4			
-	-	-	-	3			
-	-	-	-	2			
-	1	1-456414-1	CRIMPER, WIRE	1			

PACIFIC VERSION
Shown on sheets 3 of 4 & 4 of 4
(Atlantic version shown on sheets 1 of 4 & 2 of 4)

DIMENSIONS:		TOLERANCES UNLESS OTHERWISE SPECIFIED:		DRAWN H. HUANG 28NOV2012		TE Connectivity Harrisburg, PA 17105-3608	
mm	0 PLC ±	1 PLC ±	2 PLC ±	3 PLC ±	4 PLC ±	APVD S.XI 28NOV2012	NAME Ocean Side Feed Applicator
MATERIAL		FINISH		WEIGHT		SIZE CAGE CODE DRAWING NO RESTRICTED TO	
				A 00779 C=2151809		SCALE 1:2 SHEET 3 OF 4 REV F	

LOC		DIST		REVISIONS			
P	LTN	DESCRIPTION	DATE	DWN	APVD		
-	-	SEE SHEET 1	-	-	-		

FEED TYPE

PNEUMATIC

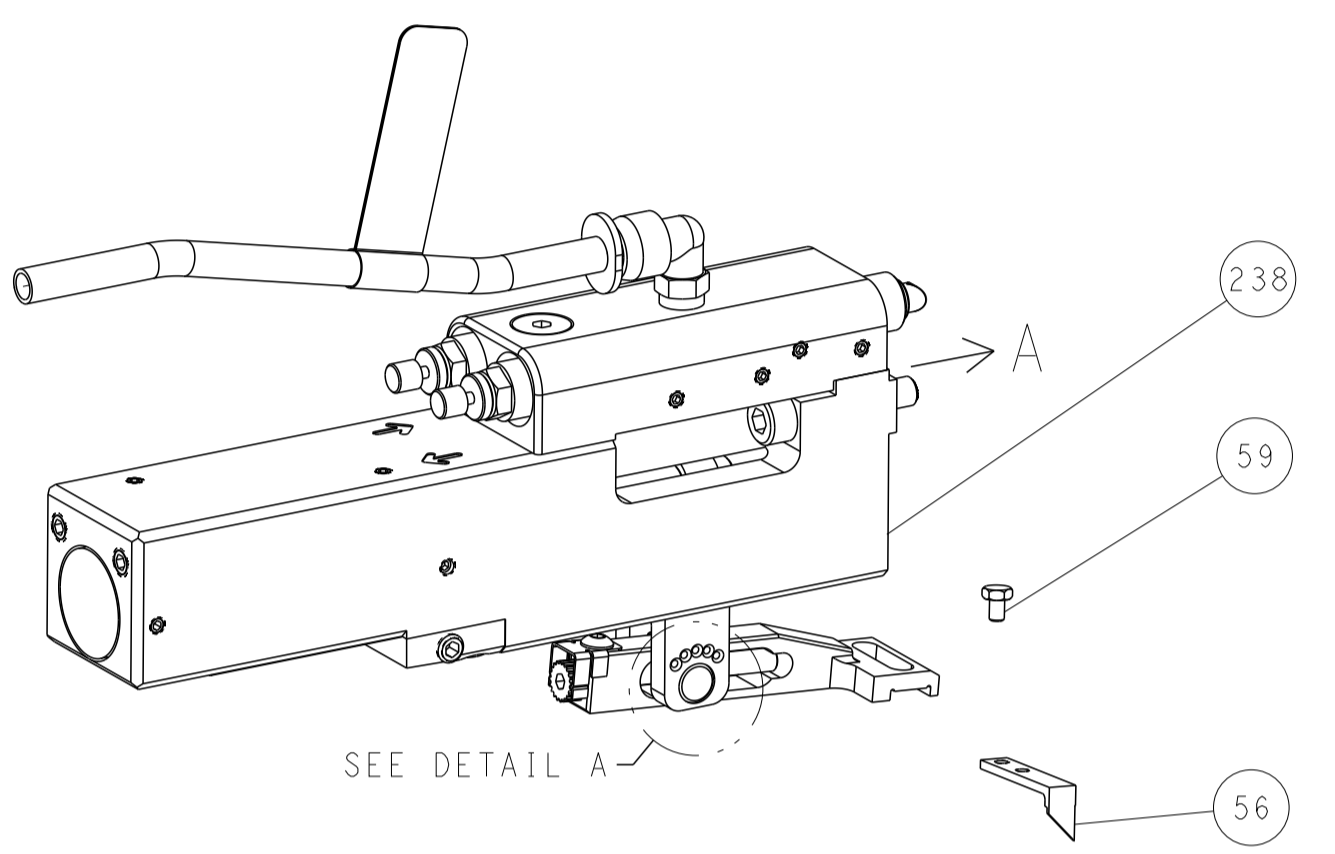

FEED SPRING SETTING POSITION (SHOWN FROM REAR SIDE)

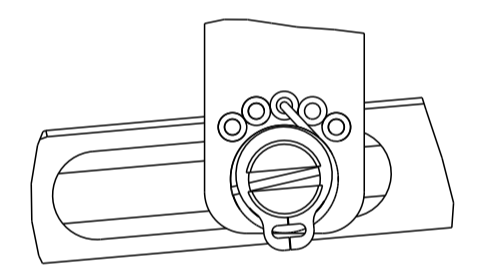

DETAIL A

CAM POSITION

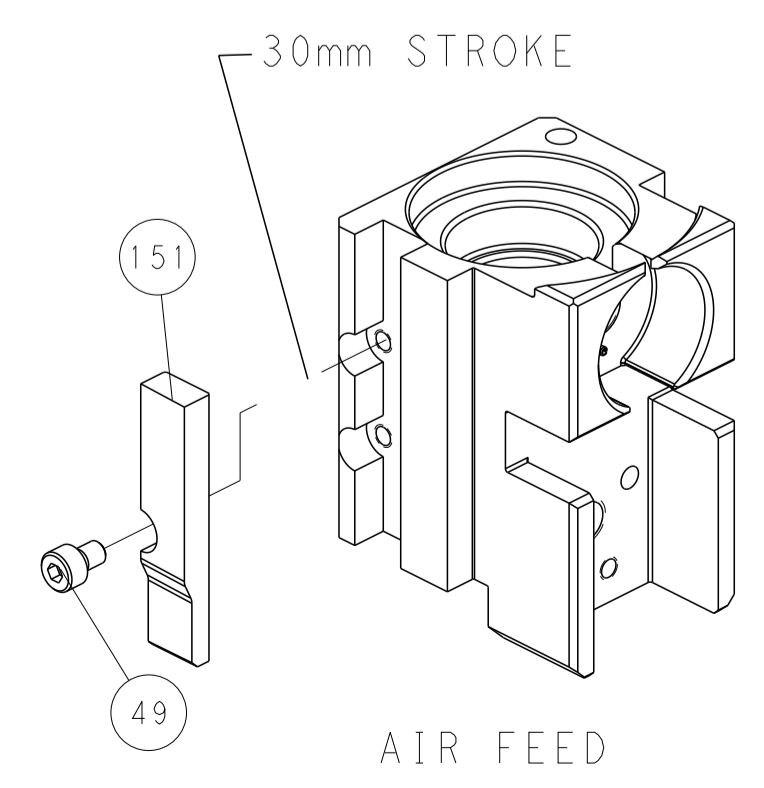

AIR FEED

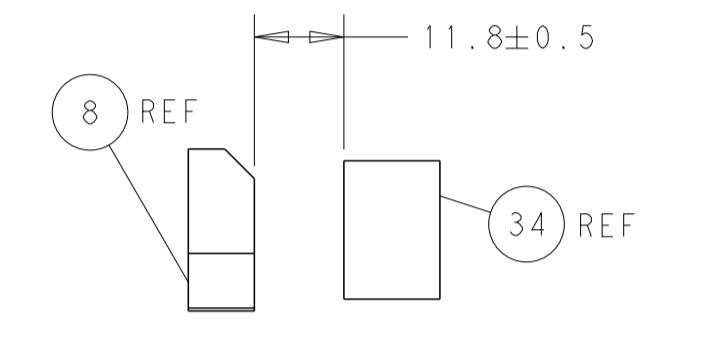
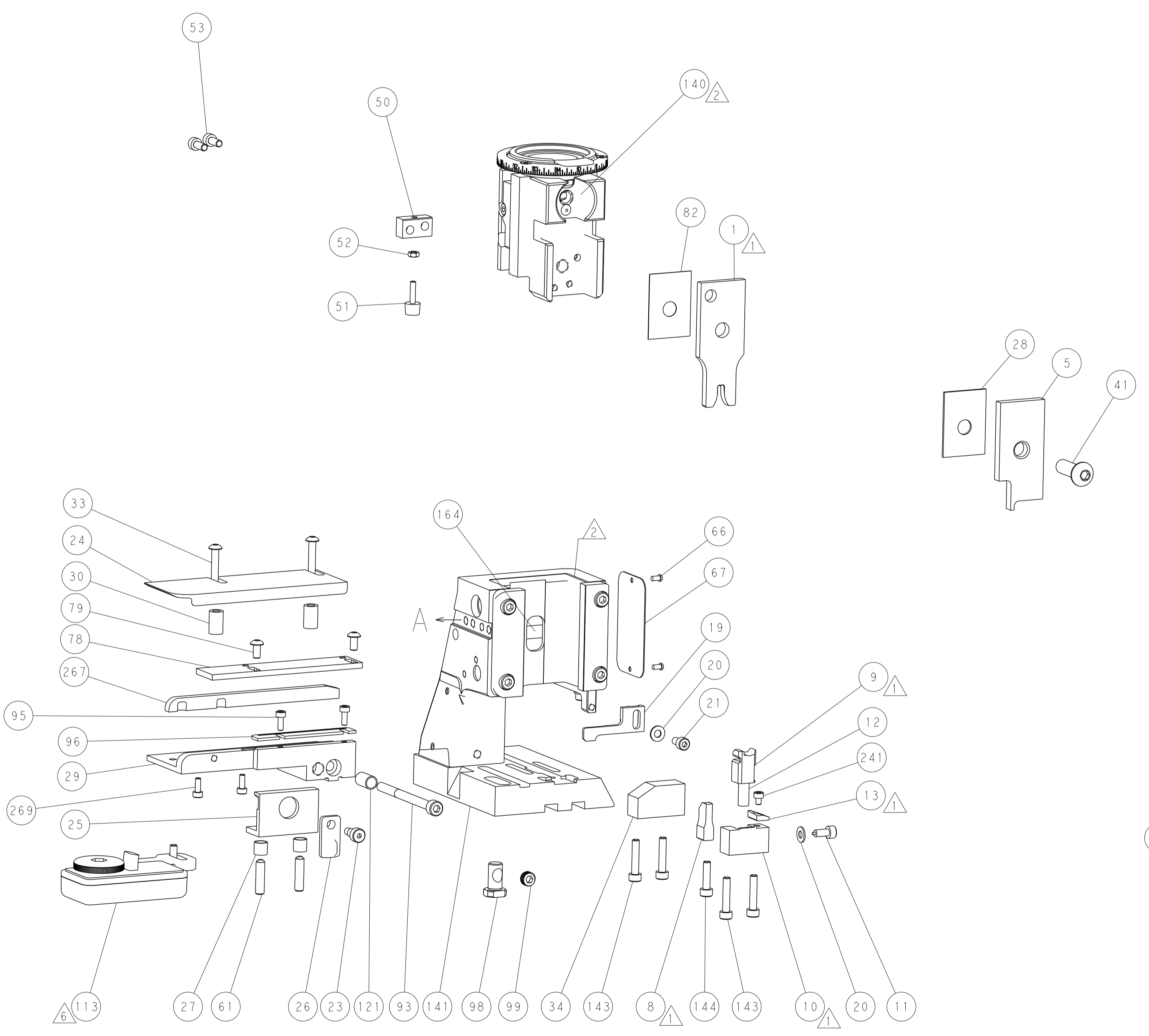

TERMINAL SUPPORT LOCATION

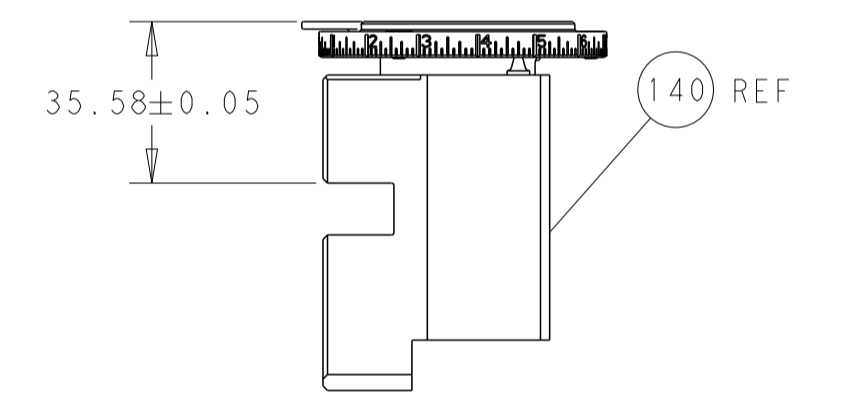

RAM SET-UP

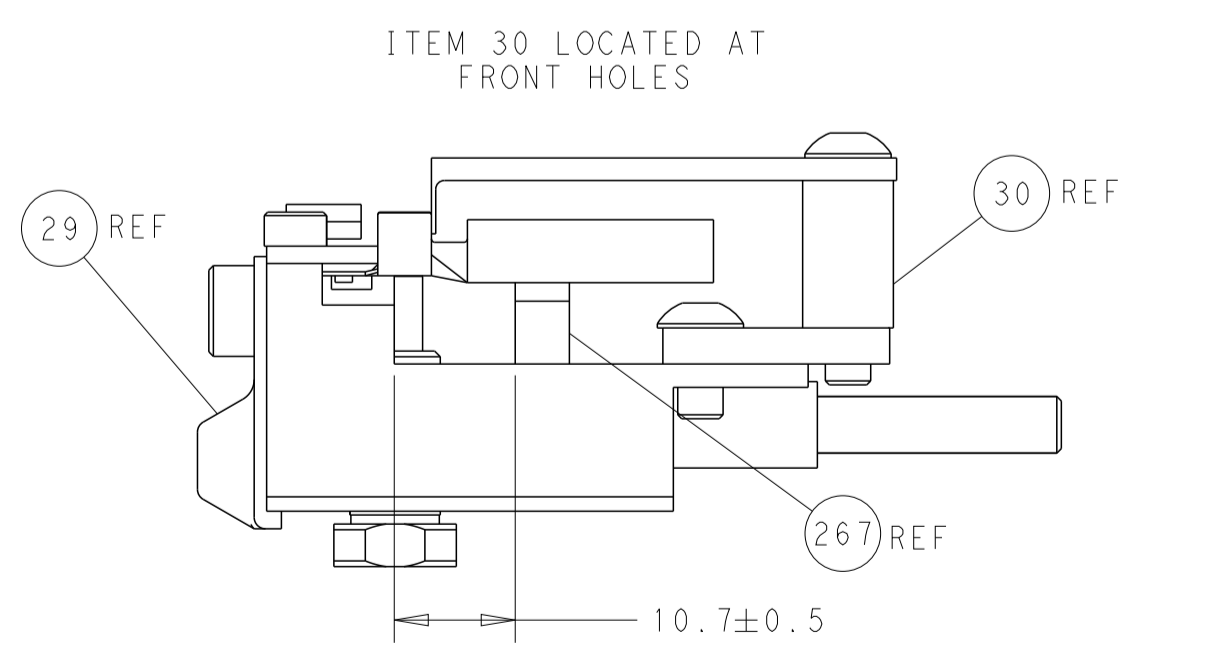

FEED TRACK POSITION GUIDE BY WIRE BARREL

PACIFIC VERSION
 Shown on sheets 3 of 4 & 4 of 4
 (Atlantic version shown on sheets 1 of 4 & 2 of 4)

DIMENSIONS:		TOLERANCES UNLESS OTHERWISE SPECIFIED:		DWN R. HUANG 28NOV2012		TE Connectivity Harrisburg, PA 17105-3608	
mm	0 PLC ±	1 PLC ±	2 PLC ±	3 PLC ±	4 PLC ±	NAME Ocean Side Feed Applicator	
MATERIAL:		FINISH:		APVD S. XI 28NOV2012		RESTRICTED TO	
				PRODUCT SPEC		SIZE CAGE CODE DRAWING NO	
				APPLICATION SPEC		A1 00779 C=2151809	
				WEIGHT		SCALE 1:2 SHEET 4 OF 4 REV F	
				Customer Accessible Production Drawing		SHEETS 1 & 2 ARE NOT REQUIRED FOR PACIFIC VERSION	