

Overview

Multilayer piezoelectric actuators are ceramic elements used to convert electrical energy into mechanical energy such as displacement or force by utilizing the piezoelectric longitudinal effect.

KEMET's multilayer piezoelectric actuators are produced based on our unique element structure design and piezoelectric ceramic materials with high electrostrictive factors. Compared to conventional piezoelectric actuators, they are smaller in size but can generate higher displacements and forces at low voltages.

The Resin Coated AE series actuators feature compact size and a wide variety of shapes for applications such as ultra-fine positioning mechanism and drive sources.

Benefits

- Large generated force of 3,500 N/cm²
- Operating temperature range from -25°C to +85°C
- High-speed response: Driving up to about 1/3 of self-resonant frequency (in several ten kHz)
- Low power consumption: Can be retained at the leakage current state of 100 µA or less
- Very small size: 1/10 or smaller than conventional multilayer actuators
- RoHS/REACH compliant

Applications

Typical applications include positioning, auto focusing of optical systems, pumps, mass-flow valves, vibration source, vibration controls, sensors, image stabilization of DSC, mirror/prism positioning, manipulators, motors and printers.



Ordering Information

AE	0505	D44	H40	D	-H0	F
Series	Ceramic Cross Section (mm)	Nominal Displacement (μm)	Overall Length (mm)	Coating Type	Hole	Environmental Compliance
AE = Resin Coated Type	0505 = 5 mm X 5 mm (Coating area is not included)	The last two digits specify the displacement values. Example: D44 = 44 μm	Blank = Standard overall lengths of 5, 10 or 20 H09 = 9 H18 = 18 H40 = 40	D = Thin coating type	Blank = No hole H0 = With hole	F = RoHS/REACH Compliant (See "Environmental Compliance" below)

Application Examples

	Application Examples
Semiconductor manufacturing system	Clamping actuator of wire bonding, actuator of shaker, actuator of damping system, positioning of light source
Precision machinery, mechatronics	Sewing machine, robot, vibration of parts feeder, positioning of equipment, pressure sensor
Home appliances	Actuator of pump
Audio equipment	Speaker
Imaging equipment	Actuator of resolution improvement, actuator of autofocusing, actuator of damping
Computer, OA equipment	Pressure sensor, positioning of memory device (data storage or others)
Optical equipment	Positioning of stage, actuator of autofocusing, actuator of shaker and damping system
Communications	Polarization control, wavelength control
Medical equipment	Micropump, ultrasonic transducer, manipulators
Measuring instrument	Pressure sensor, acceleration sensor, fine positioning
Automotive	Vibration Control

Element Structure

KEMET's multilayer piezoelectric actuators are designed using unique element structure technology and proprietary ceramic materials with high electrostrictive factors.

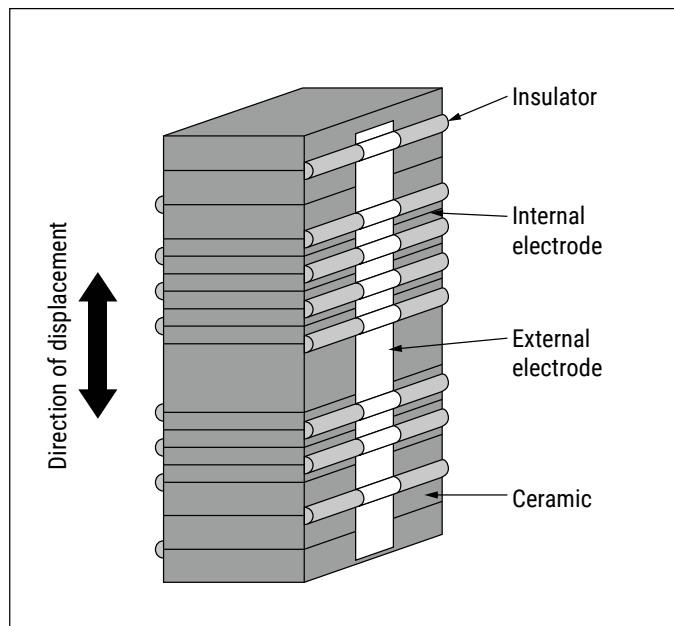

This particular structure and technology involved provide a unique product with below advantages compared to other similar solutions:

Against electromagnetic actuators

- Faster response
- Higher resolution for positioning
- Large generated force
- Low power consumption
- No electromagnetic noise

Against bimorph piezoelectric actuators

- 7 times the energy conversion efficiency of the bimorph type actuator
- Lower power consumption
- Large generated force
- Stable displacement, reduced shift and creep phenomena
- 100 times the response speed of the bimorph piezoelectric actuator

Against stacked piezoelectric actuators

- Compact size (less than 1/10 the specific volume of the stacked piezoelectric actuator)
- Low drive voltage
- Easy to use
- Inexpensive

Dimensions in mm

Outer dimensions in mm

Overall length 10 and 20 mm Products

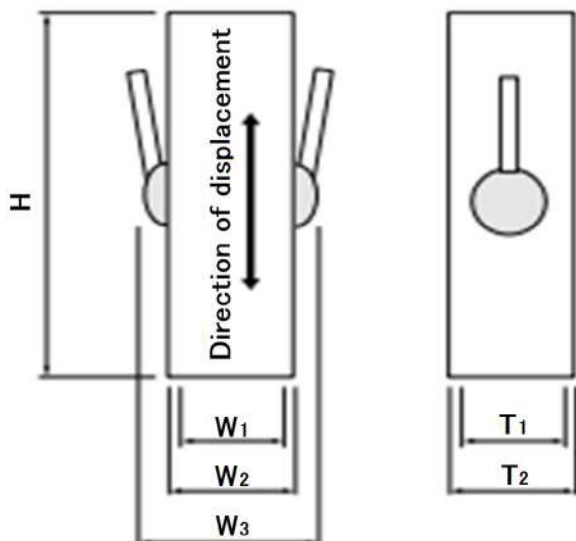

Overall length 5, 9, 18 and 40 mm Products

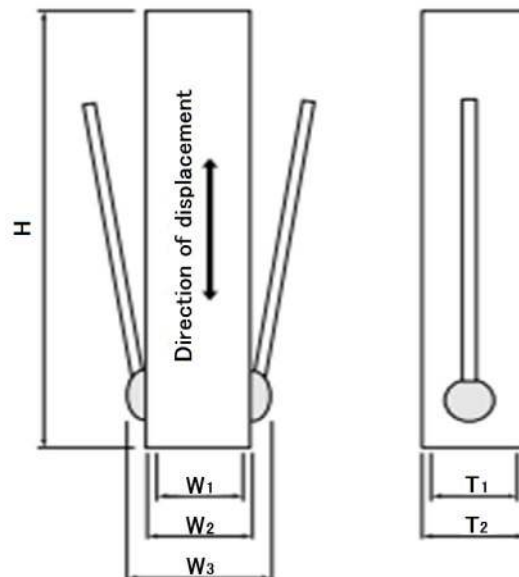

Note:

Factory-shipped polarization:

Red lead wire = (+)

White lead wire = (-)

Above drawings do not include dimension of wire connection area and diameter of the wire. Please contact KEMET for details.

Part Number	Outer Dimensions (mm)					
	H ±0.1	T ₁ ±0.1	W ₁ ±0.1	T ₂ Maximum	W ₂ Maximum	W ₃ Maximum
AE0203D04DF	5					
AE0203D08H09DF	9					
AE0203D08DF	10					
AE0203D18H18DF	18	2.0	3.0	2.4	3.4	5.5
AE0203D16DF	20					
AE0203D44H40DF	40					
AE035035D08H09DF	9					
AE035035D18H18DF	18	3.5	3.5	3.9	3.9	6.0
AE0505D04D-H0F	5					
AE0505D08D-H0F	10					
AE0505D08H09DF	9					
AE0505D08DF	10	5.0	5.0	5.4	5.4	7.5
AE0505D18H18DF	18					
AE0505D16DF	20					
AE0505D44H40DF	40					
AE0707D08H09DF	9					
AE0707D08DF	10					
AE0707D18H18DF	18	7.0	7.0	7.4	7.4	9.5
AE0707D16DF	20					
AE0707D44H40DF	40					
AE1010D08H09DF	9					
AE1010D18H18DF	18					
AE1010D16DF	20	10.0	10.0	10.4	10.4	12.5
AE1010D44H40DF	40					
AE1414D16DF	20	14.2	14.2	14.6	14.6	16.7
AE2525D15DF	20	25.1	25.1	25.5	25.5	27.6

Dimensions in mm cont.

Wire dimensions in mm

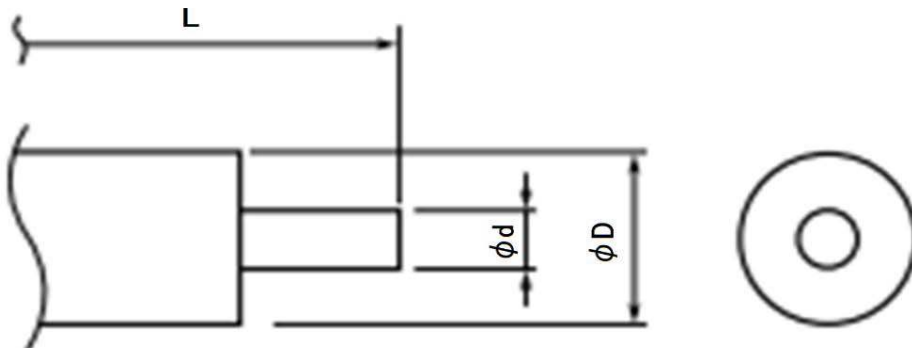

Note:

ϕd = Diameter of lead wire

ϕD = Outer diameter including the thickness of coating

L = Lead wire length

Lead wire : Copper wire with Tin plating

Coating : PTFE (Polytetrafluoroethylene)

Part Number	Wire Dimensions									
	AWG	ϕd	ϕD	L	UL Number					
AE0203D04DF	30	0.3	0.5	100	1993					
AE0203D08H09DF										
AE0203D08DF										
AE0203D18H18DF										
AE0203D16DF										
AE0203D44H40DF										
AE035035D08H09DF										
AE035035D18H18DF										
AE0505D04D-H0F										
AE0505D08D-H0F										
AE0505D08H09DF	26	0.5	0.8	100	1993					
AE0505D08DF										
AE0505D18H18DF										
AE0505D16DF										
AE0505D44H40DF										
AE0707D08H09DF						30	0.3	0.5	100	1993
AE0707D08DF										
AE0707D18H18DF										
AE0707D16DF										
AE0707D44H40DF										
AE1010D08H09DF	26	0.5	0.8	100	1993					
AE1010D18H18DF										
AE1010D16DF										
AE1010D44H40DF										
AE1414D16DF										
AE2525D15DF										

Dimensions in mm cont.

AE0203D04DF

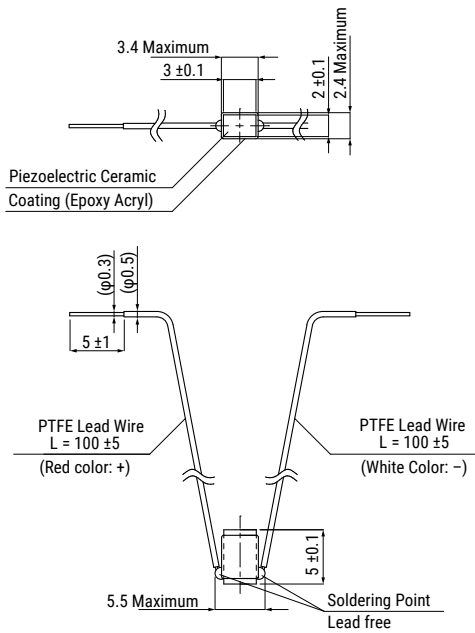

AE0203D08H09DF

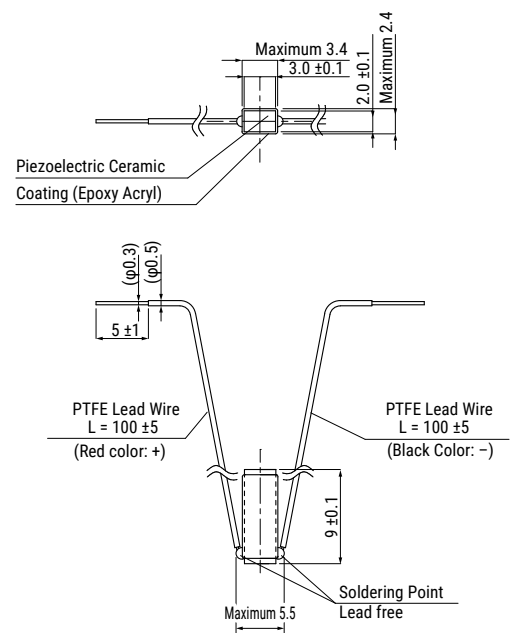

AE0203D08DF

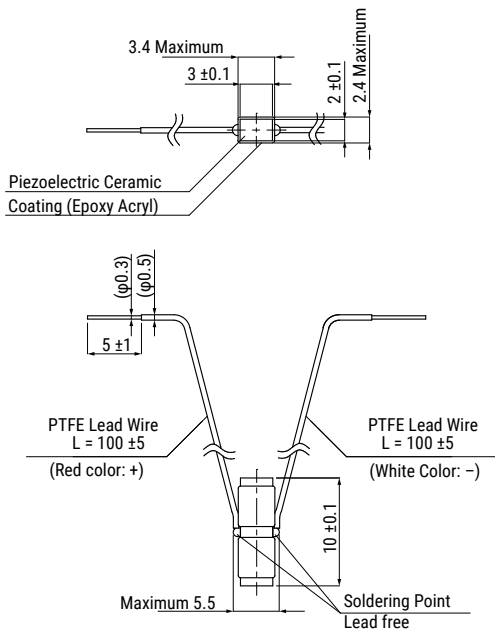

AE0203D18H18DF

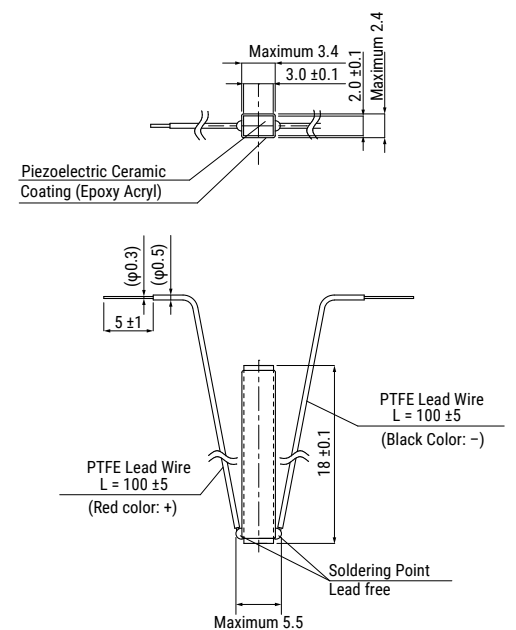

Dimensions in mm cont.

AE0203D16DF

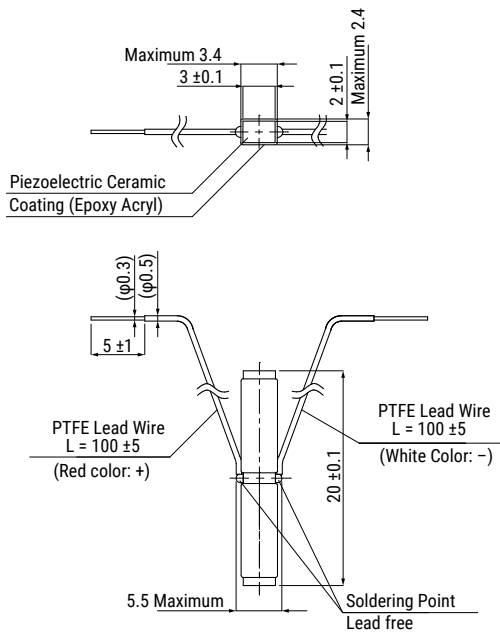

AE0203D44H40DF

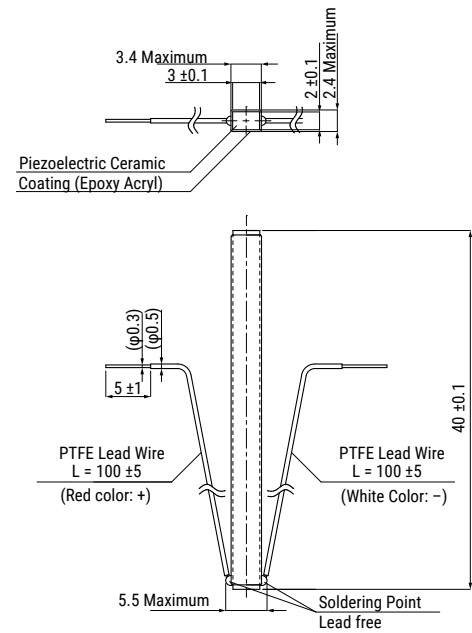

AE035035D08H09DF

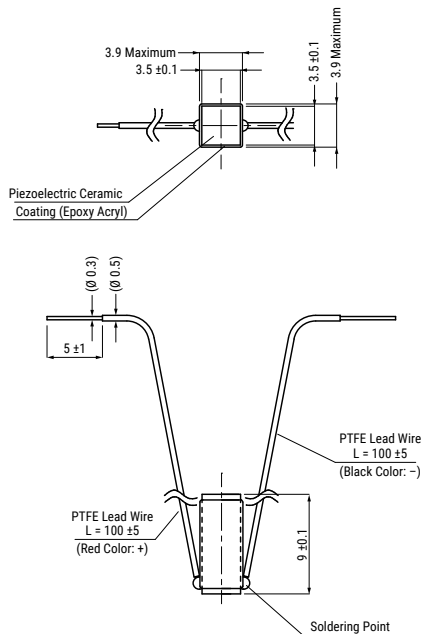

AE035035D18H18DF

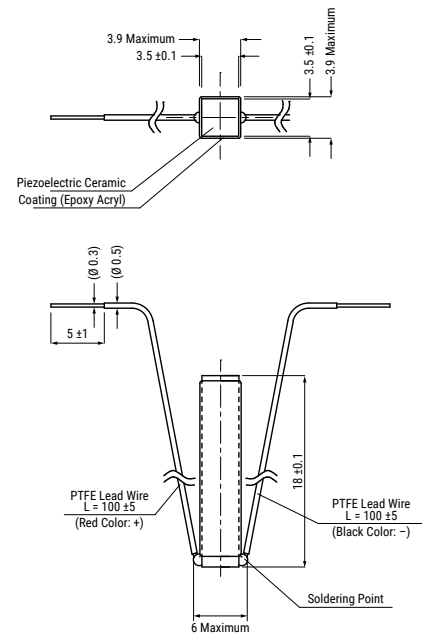

Dimensions in mm cont.

AE0505D04D-H0F

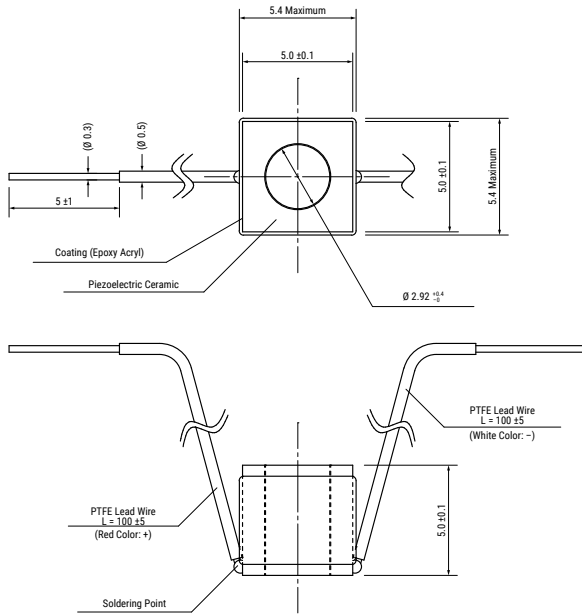

AE0505D08D-H0F

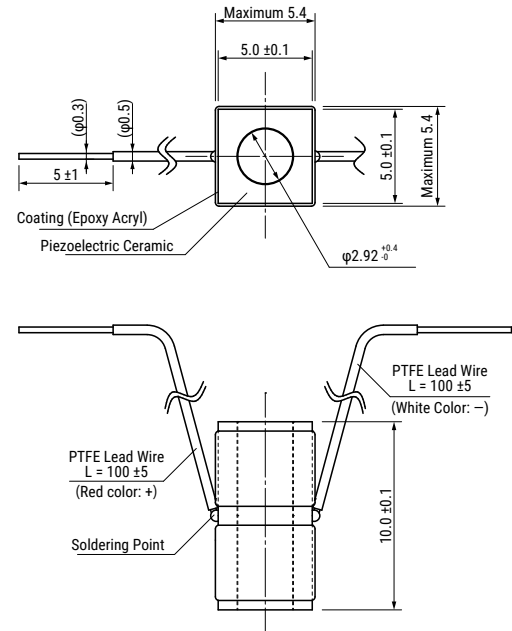

AE0505D08H09DF

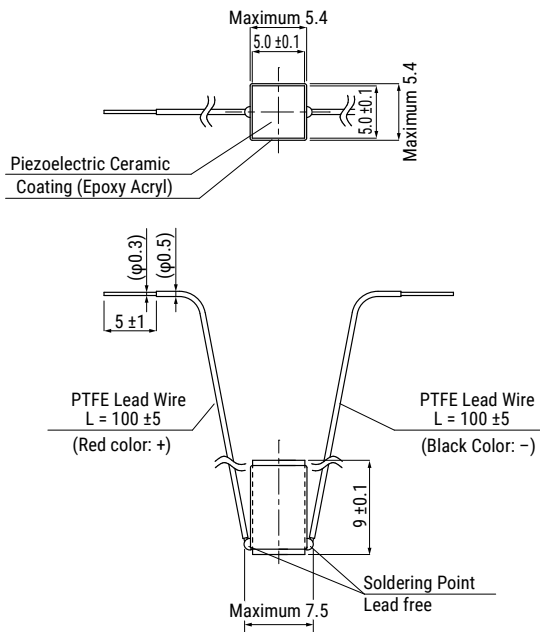

AE0505D08DF

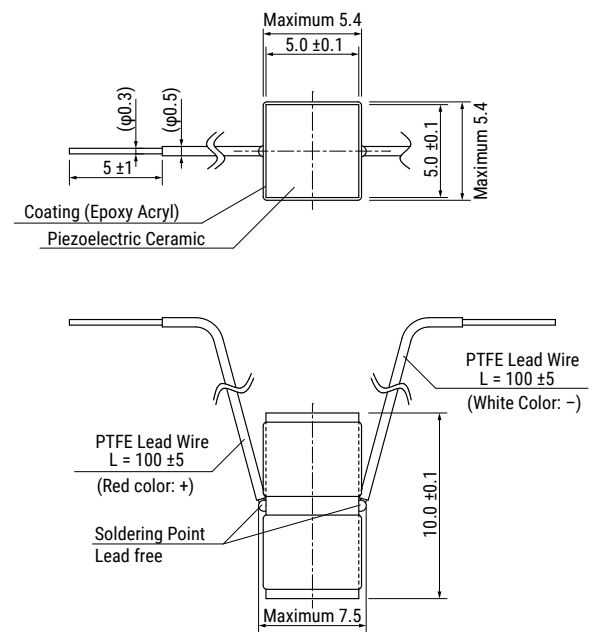

Dimensions in mm cont.

AE0505D18H18DF

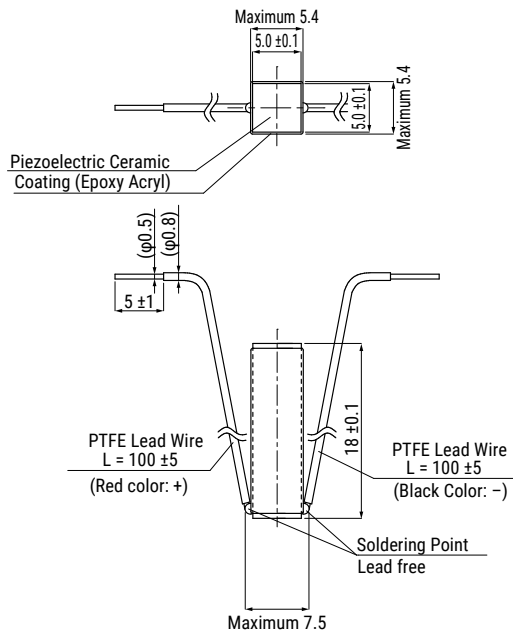

AE0505D16DF

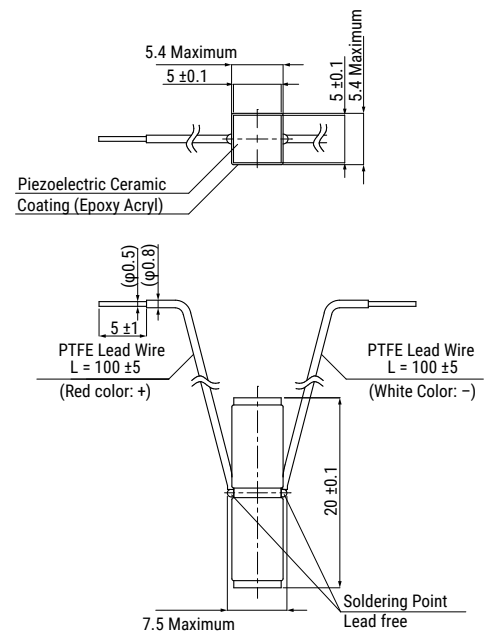

AE0505D44H40DF

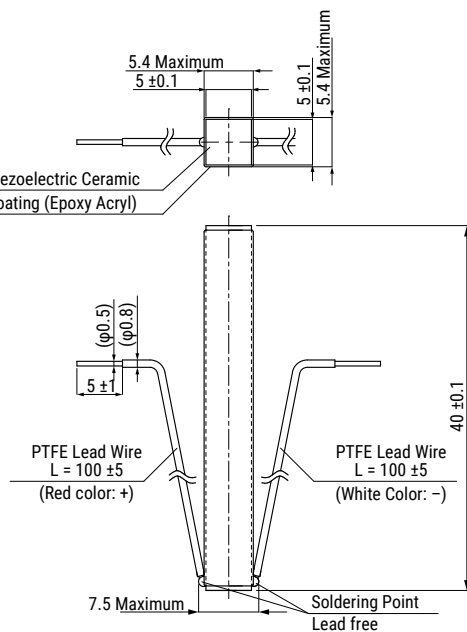

AE0707D08H09DF

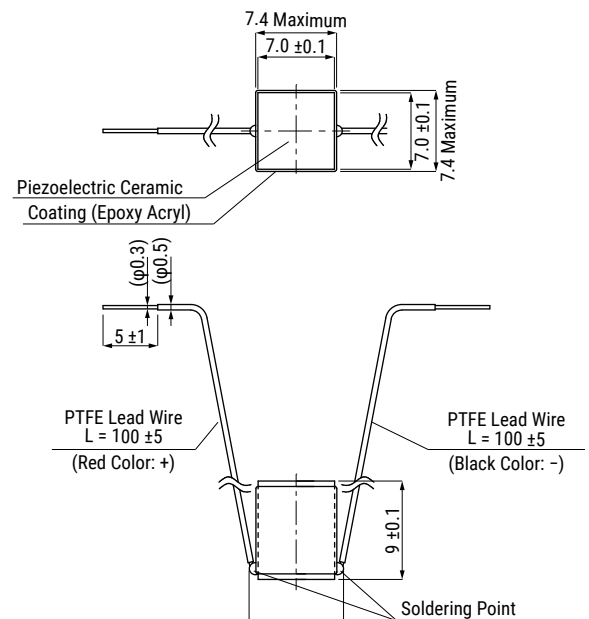

Dimensions in mm cont.

AE0707D08DF

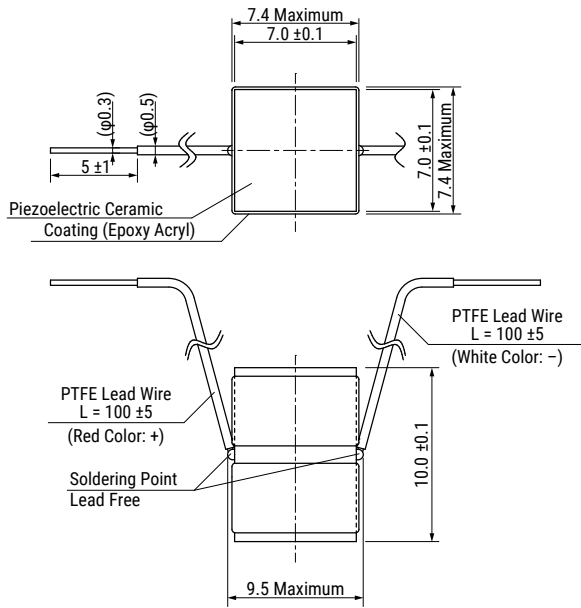

AE0707D18H18DF

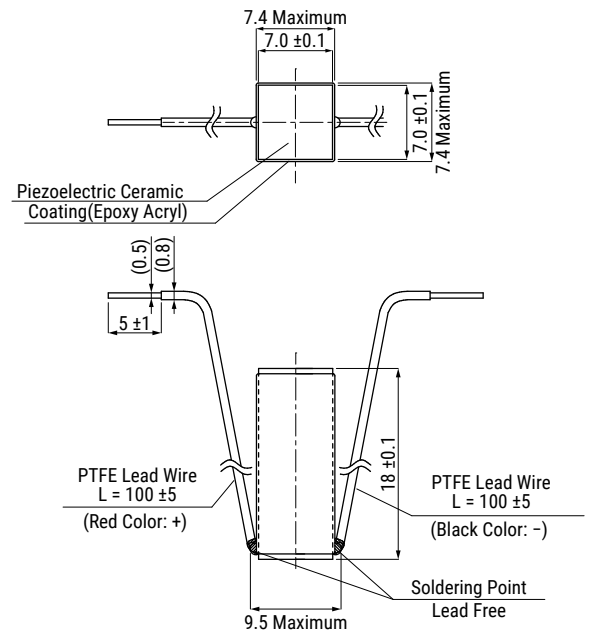

AE0707D16DF

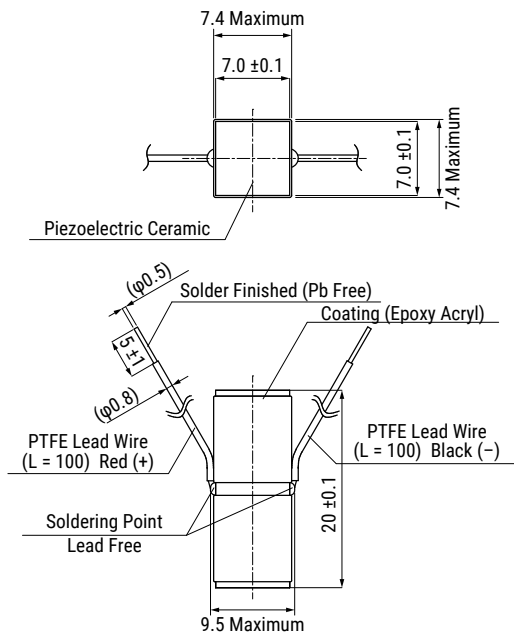

AE0707D44H40DF

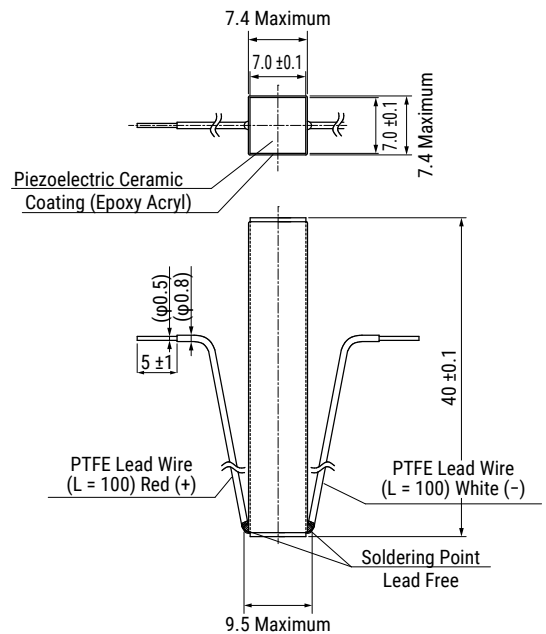

Dimensions in mm cont.

AE1010D08H09DF

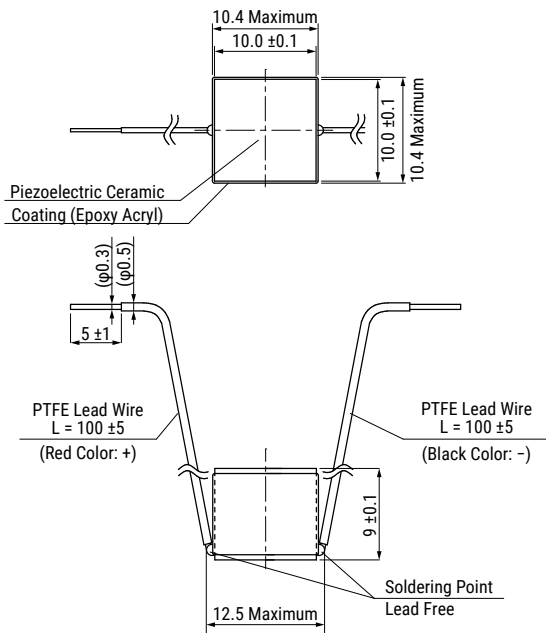

AE1010D18H18DF

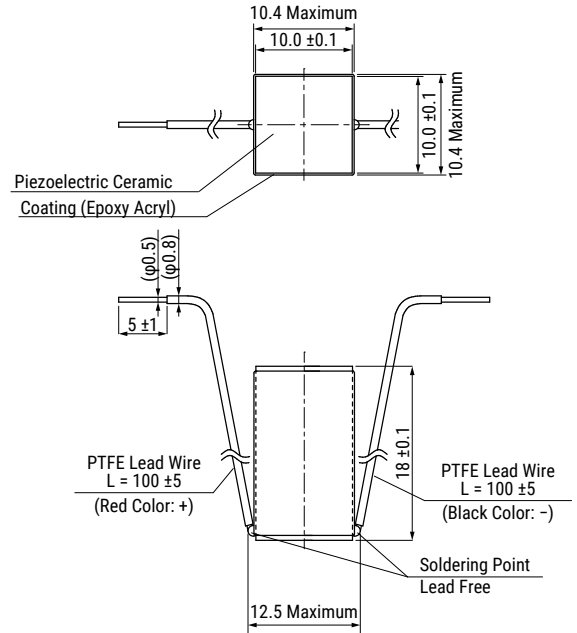

AE1010D16DF

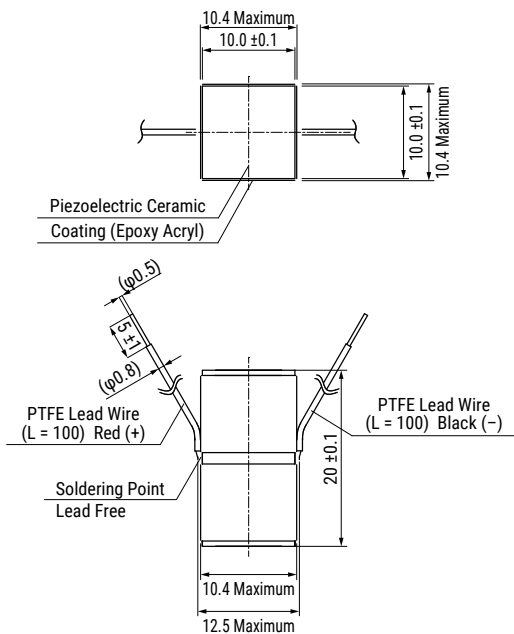

AE1010D44H40DF

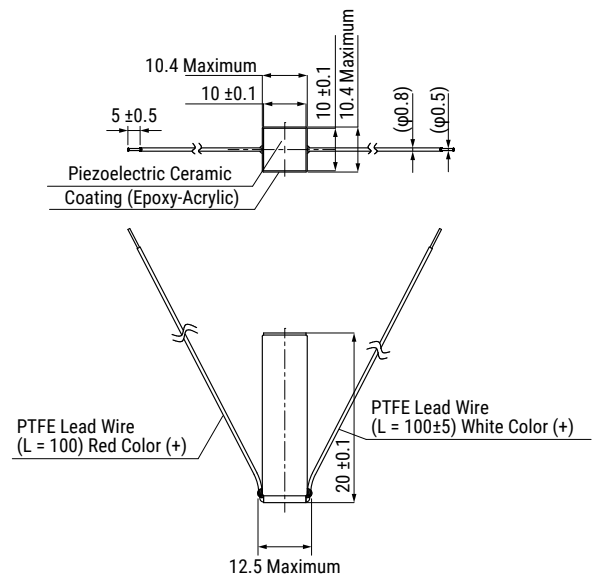

Dimensions in mm cont.

AE1414D16DF

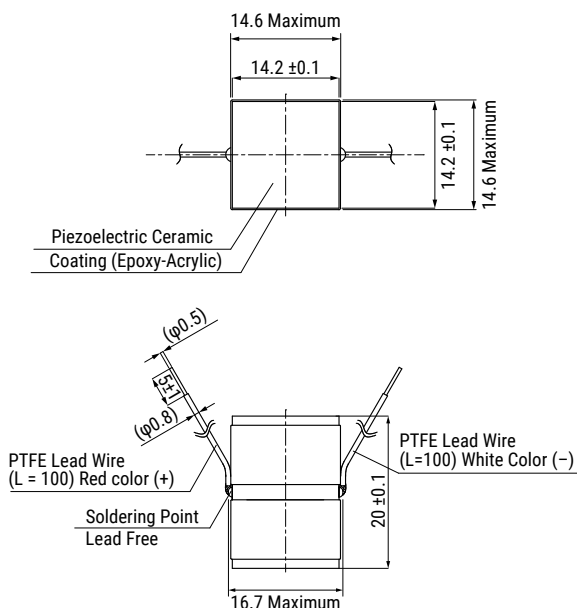

AE2525D15DF

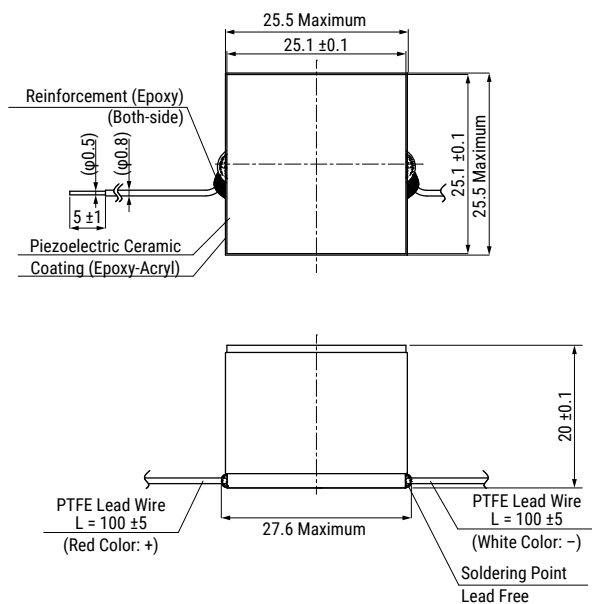

Performance Characteristics

Item	Performance Characteristics	Conditions
Operating Temperature Range	-25 to +85°C	When applied with a DC voltage at ambient temperature. When driven by an AC voltage at ambient temperature plus temperature rise due to heat generation.
Recommended Storage Condition	-5 to +40°C / less than 40% R.H.	No condensation. Recommended storage to be at room temperature.
Maximum Driving Voltage	150 VDC	
Displacement	See Table 1 - Ratings & Part Number Reference	At 150 VDC
"Generated Force (Compression Resistance)"	See Table 1 - Ratings & Part Number Reference	The force required for restricting the displacement to zero when the maximum driving voltage is applied.
Capacitance	See Table 1 - Ratings & Part Number Reference	f = 1 kHz, V = 1 Vrms (< 10 μF) f = 120 Hz, V = 1 Vrms (> 10 μF)
Capacitance Tolerance	±20%	
Dissipation Factor	5% or less	
Insulation Resistance	See Table 1 - Ratings & Part Number Reference	Value obtained in one minute at 150 VDC.
Resonance Frequency	See Table 1 - Ratings & Part Number Reference	Both ends of the element are in free state. Typical values of the element under our test conditions.
Tensile Strength	1/10 of generated force	Typical values of the element under our test conditions.
Young's Modulus	4.4 X 10 ¹⁰ N/m ²	Typical values of the element under our test conditions.
Temperature Cycle Test	Displacement: Initial value ±20% Capacitance: Initial value ±30% tan δ: Less than initial rated value Insulation Resistance: 1 MΩ or more	Room temperature (3 minutes) At -25°C for 30 minutes Room temperature (3 minutes) At +85°C for 30 minutes Repetition of 10 cycles of the above

Environmental Compliance

All KEMET Multilayer Piezoelectric Actuators are RoHS and REACH Compliant.

Article 33(1) of the REACH Regulation states that manufacturers and importers of articles (products) are required to notify their customers of the presence of any Substances of Very High Concern (SVHC) in their products exceeding 0.1% by weight and provide instructions on safe use of the product.

KEMET Corporation reports regarding the Article 33(1) of REACH Regulation as follows:

1. Applicable Product:

Multilayer piezoelectric actuators (AE, AER, ASB, ASL and AHB Series).

2. Report for content of REACH SVHC list:

The product(s) above contain a substance by more than 0.1wt% per product weight that was published in the 8th update of the REACH SVHC substances (December 19, 2012).

3. Regarding safety of the multilayer piezoelectric actuators (Piezoceramic products):

The Piezoceramic that is used in this product becomes ceramic by sintering powder containing PZT as a main ingredient. It is chemically stable, with minimum risks toward the human body or environment within the intended use of the product. Please note that risks could occur in the case of inhalation or accidental oral uptake of powder ceramics.

4. Technical product information on the multilayer piezoelectric actuators (Piezoceramic products):

The manufacturing technique of the “piezoceramic products” whose main ingredient is Lead Titanium Zirconium Oxide (PZT) has been established, and there is no alternative material that can exhibit superior performance than PZT at this moment. Please note that the piezoceramic is listed as an exempt on RoHS (2011/65/EU) Annex III (7c.1).

5. Responsibility of piezoceramic manufacturers:

Piezoceramic manufacturers report information regarding PZT containment in their products to the customers to obey the article 33 of the REACH regulation.



Table 1 – Ratings & Part Number Reference

Part Number	Electrical			Energy/ Power	Physical				
	Capacitance (μ F)	Resonance Frequency (kHz)	Insulation Resistance (M Ω)	Generated Force (N)	Cross Section (mm)	Overall Length (mm)	Displacement (μ m) at Maximum Voltage of 150 VDC	Stiffness (N/ μ m)	Weight (g)
AE0203D04DF	0.09	261	100.0	200	2X3	5	4.6 \pm 1.5	43.5	0.4
AE0203D08H09DF	0.16	152	100.0	200	2X3	9	8.0 \pm 2.0	25.0	0.7
AE0203D08DF	0.18	138	100.0	200	2X3	10	9.1 \pm 1.5	22.0	0.8
AE0203D18H18DF	0.40	76	50.0	200	2X3	18	19.0 \pm 2.0	10.5	1.4
AE0203D16DF	0.35	69	50.0	200	2X3	20	17.4 \pm 2.0	11.5	1.6
AE0203D44H40DF	0.82	34	20.0	200	2X3	40	42.0 \pm 6.6	47.6	2.5
AE035035D08H09DF	0.33	152	50.0	410	3.5X3.5	9	8.5 \pm 1.5	48.2	1.2
AE035035D18H18DF	0.80	76	10.0	410	3.5X3.5	18	19.0 \pm 2.0	21.6	2.3
AE0505D04D-H0F	0.27	261	10.0	610	5X5/ID3	5	4.6 \pm 1.5	132.6	1.1
AE0505D08D-H0F	0.54	138	10.0	610	5X5/ID3	10	9.1 \pm 1.5	67.0	1.6
AE0505D08H09DF	0.68	152	50.0	850	5X5	9	8.7 \pm 1.5	97.7	2.4
AE0505D08DF	0.75	138	50.0	850	5X5	10	9.1 \pm 1.5	93.4	2.6
AE0505D18H18DF	1.60	76	10.0	850	5X5	18	19.0 \pm 2.0	44.7	4.7
AE0505D16DF	1.40	69	10.0	850	5X5	20	17.4 \pm 2.0	48.9	5.2
AE0505D44H40DF	3.40	34	5.0	850	5X5	40	42.0 \pm 6.6	20.2	11.0
AE0707D08H09DF	1.40	152	10.0	1,700	7x7	9	8.7 \pm 1.5	195.4	3.8
AE0707D08DF	1.50	138	10.0	1,700	7x7	10	9.1 \pm 1.5	186.8	5.0
AE0707D18H18DF	3.40	76	5.0	1,700	7x7	18	19.0 \pm 2.0	89.5	8.0
AE0707D16DF	3.40	69	5.0	1,700	7x7	20	17.4 \pm 2.0	97.7	9.0
AE0707D44H40DF	6.70	34	5.0	1,700	7x7	40	42.0 \pm 6.6	40.5	17.0
AE1010D08H09DF	2.90	152	10.0	3,500	10X10	9	9.0 \pm 2.0	388.9	9.0
AE1010D18H18DF	6.60	76	5.0	3,500	10X10	18	20.0 \pm 3.5	175.0	19.0
AE1010D16DF	5.40	69	5.0	3,500	10X10	20	18.4 \pm 3.5	190.2	20.0
AE1010D44H40DF	13.60	34	2.0	3,500	10X10	40	42.0 \pm 6.6	83.3	36.0
AE1414D16DF	10.80	69	2.0	7,000	14X14	20	18.4 \pm 3.5	380.4	38.0
AE2525D15DF	30.50	69	0.4	20,000	25X25	20	15.6 \pm 2.0	1282.0	105.0

Custom Design Parts

Customized parts are available on request. Please contact KEMET.

Below guidelines can be used as reference regarding generated displacement and generated force.

Item	Characteristics
Displacement	Roughly proportional to the length of the element
Generated Force	Roughly proportional to the sectional area of the element
Product Cross Section	1 x 1 mm square or larger
Product Length	1 mm or longer
Product Shape	Available in cylindrical ring or other shapes

Electrical Characteristics

Figure 1 - Voltage vs. Displacement

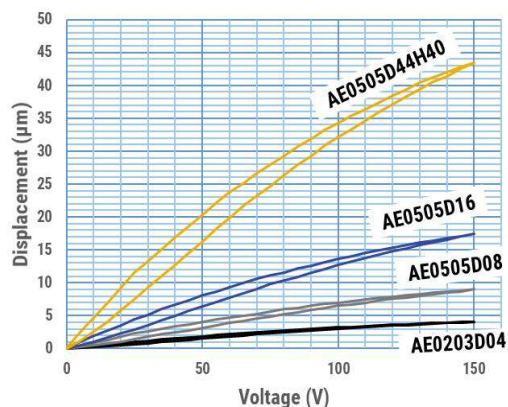

Figure 2 - Generated Force vs. Displacement of AE0505D16F in Driving Voltage

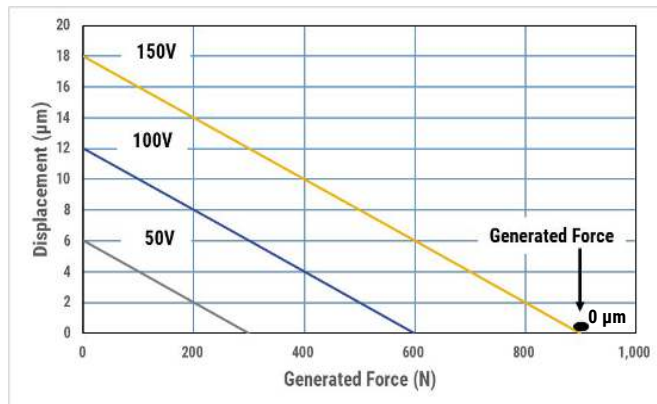

Figure 3 - Generated Force vs. Displacement - 1

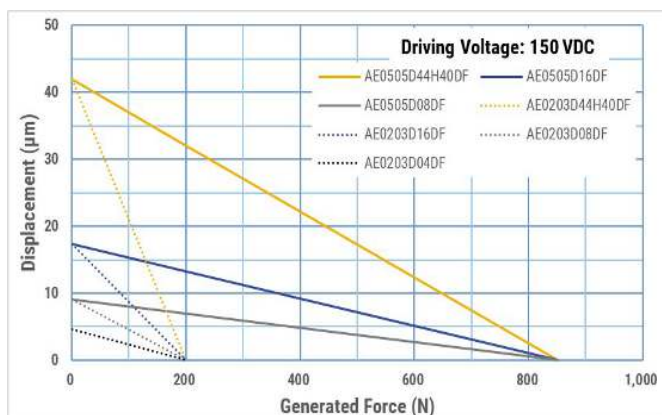

Figure 4 - Generated Force vs. Displacement - 2

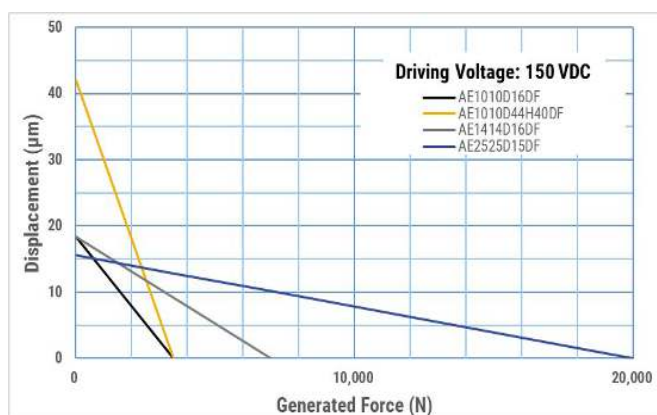

Figure 5 - Temperature vs. Displacement

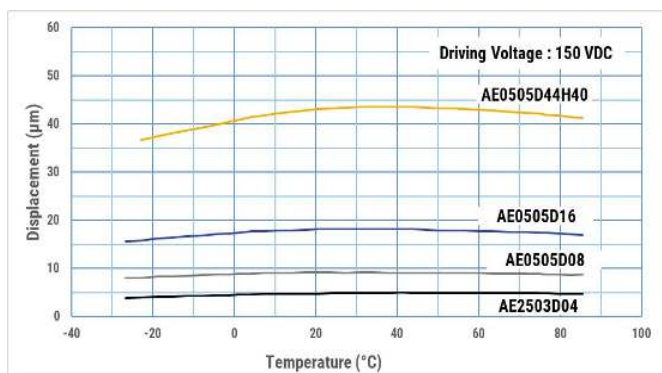
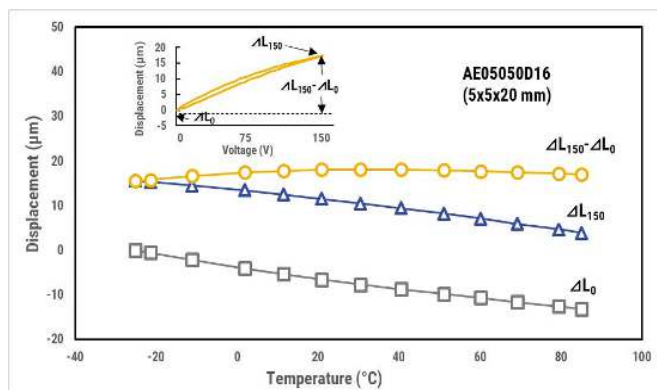

Figure 6 - Temperature vs. Displacement



Notes:

* Listed data are reference values. For the voltage vs. displacement characteristics, the same length of piezo series shows the same voltage vs. displacement characteristics.

* Definition of generated force for figures 2, 3 and 4: force required for restricting the displacement to 0 when the maximum driving voltage is applied.

Electrical Characteristics cont.

Figure 7 - Voltage vs. Displacement in Time

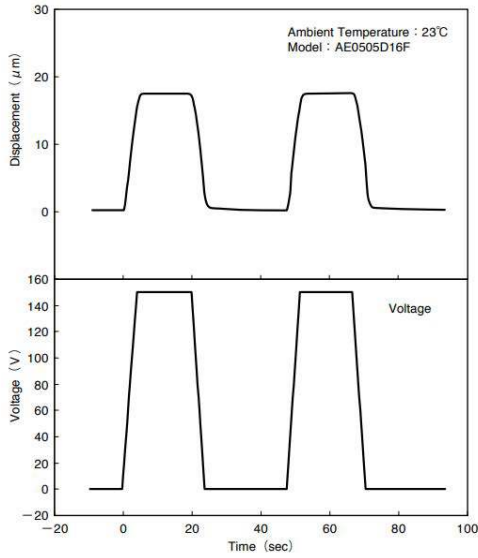

Figure 8 - Heat Generation vs. Drive Frequency - 1

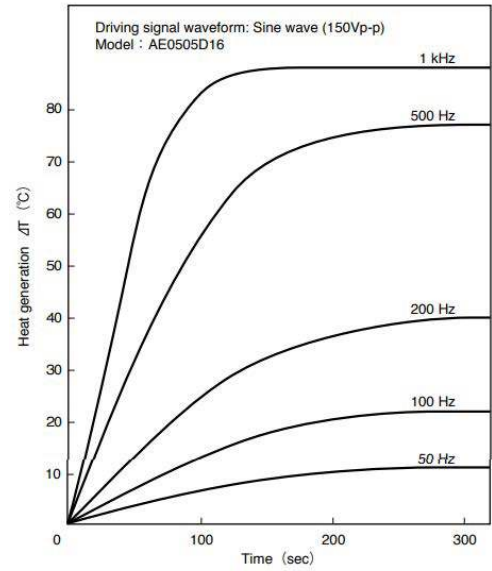
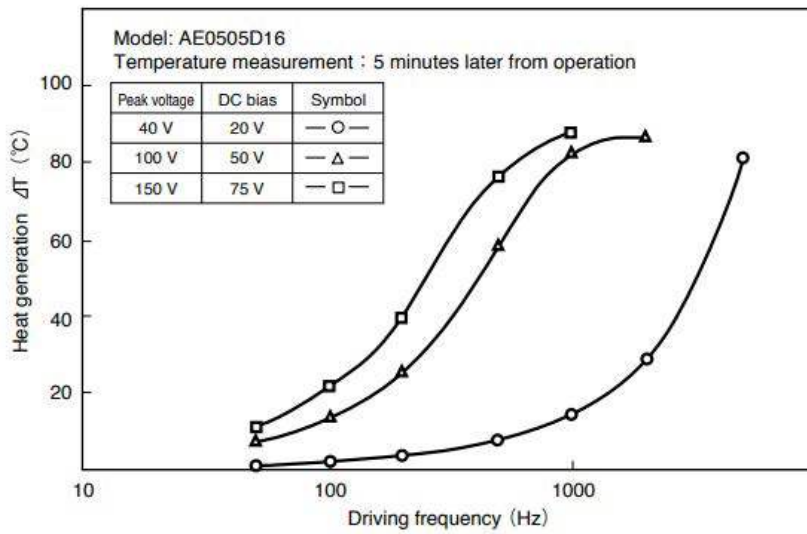
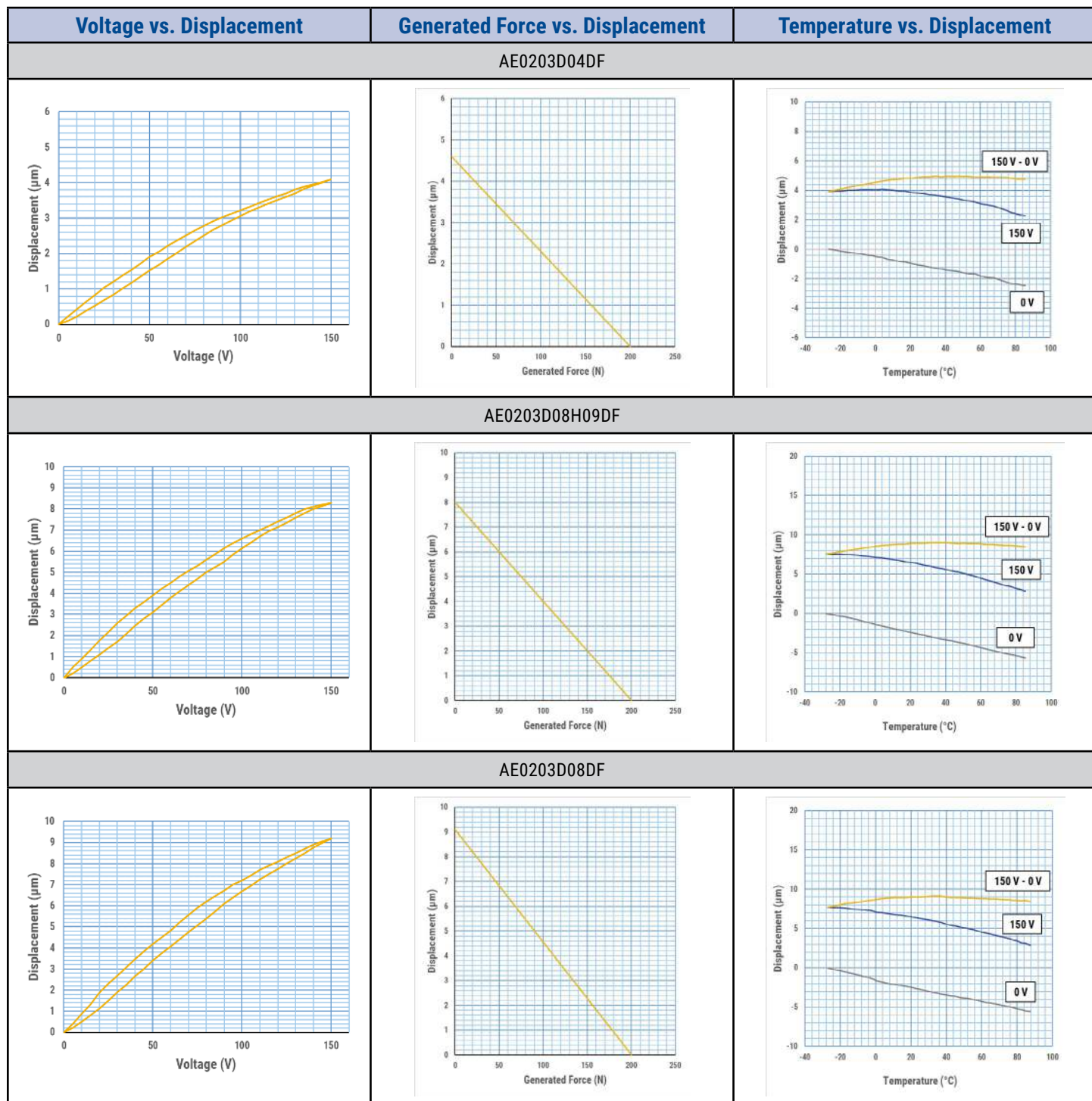

Figure 9 - Heat Generation vs. Drive Frequency - 2



Electrical Characteristics cont.



Electrical Characteristics cont.

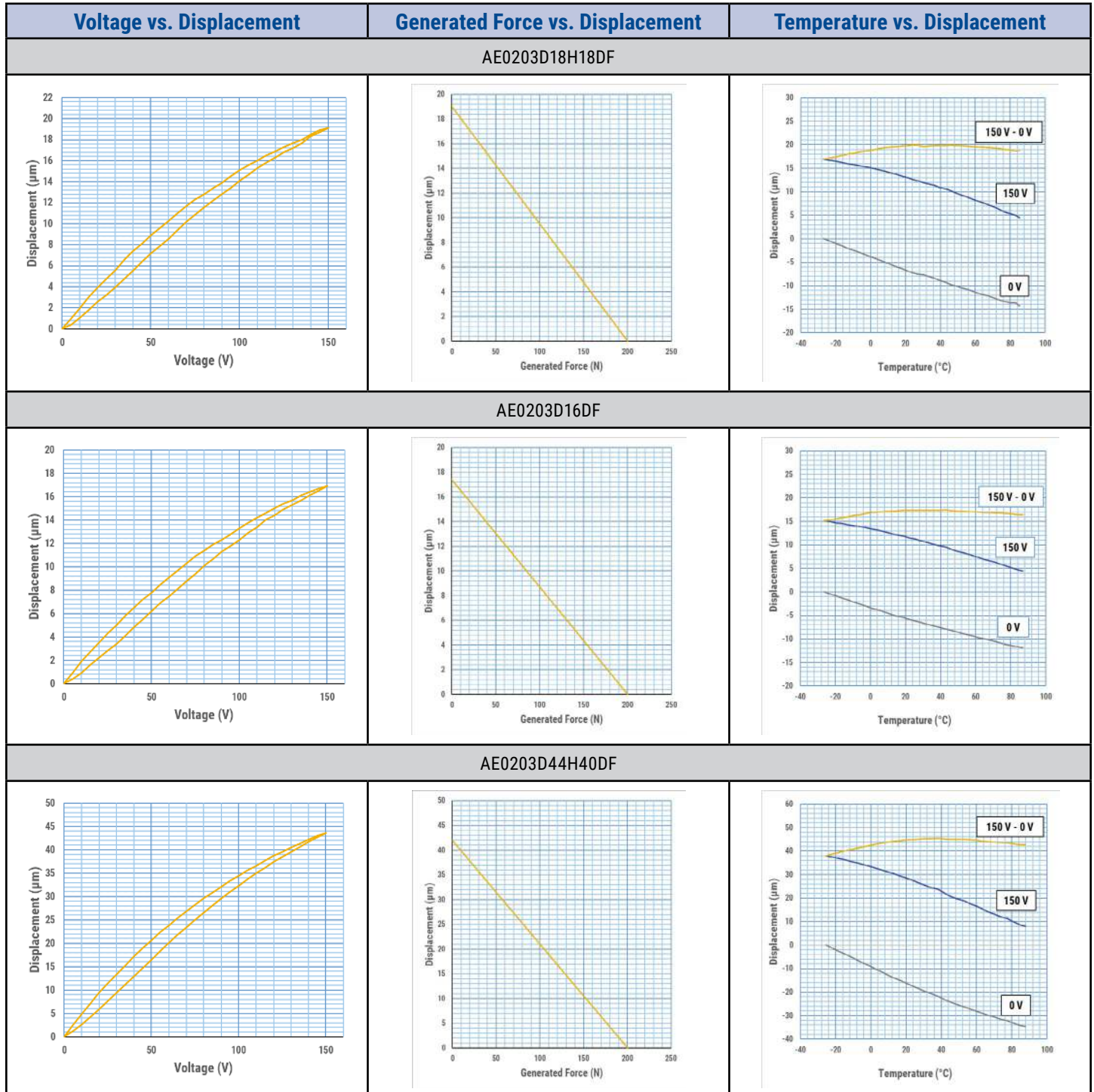

Electrical Characteristics cont.

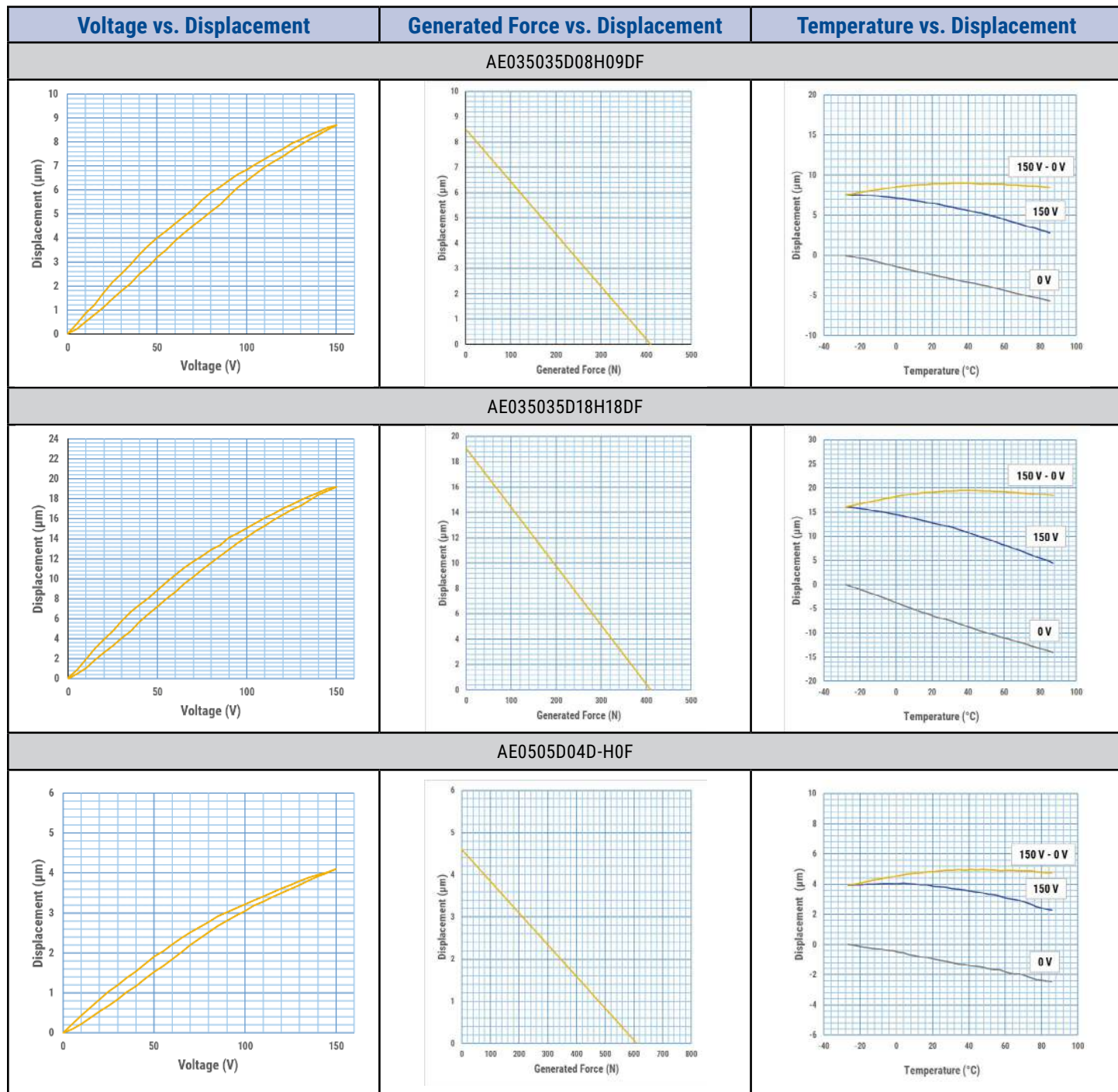

Electrical Characteristics cont.

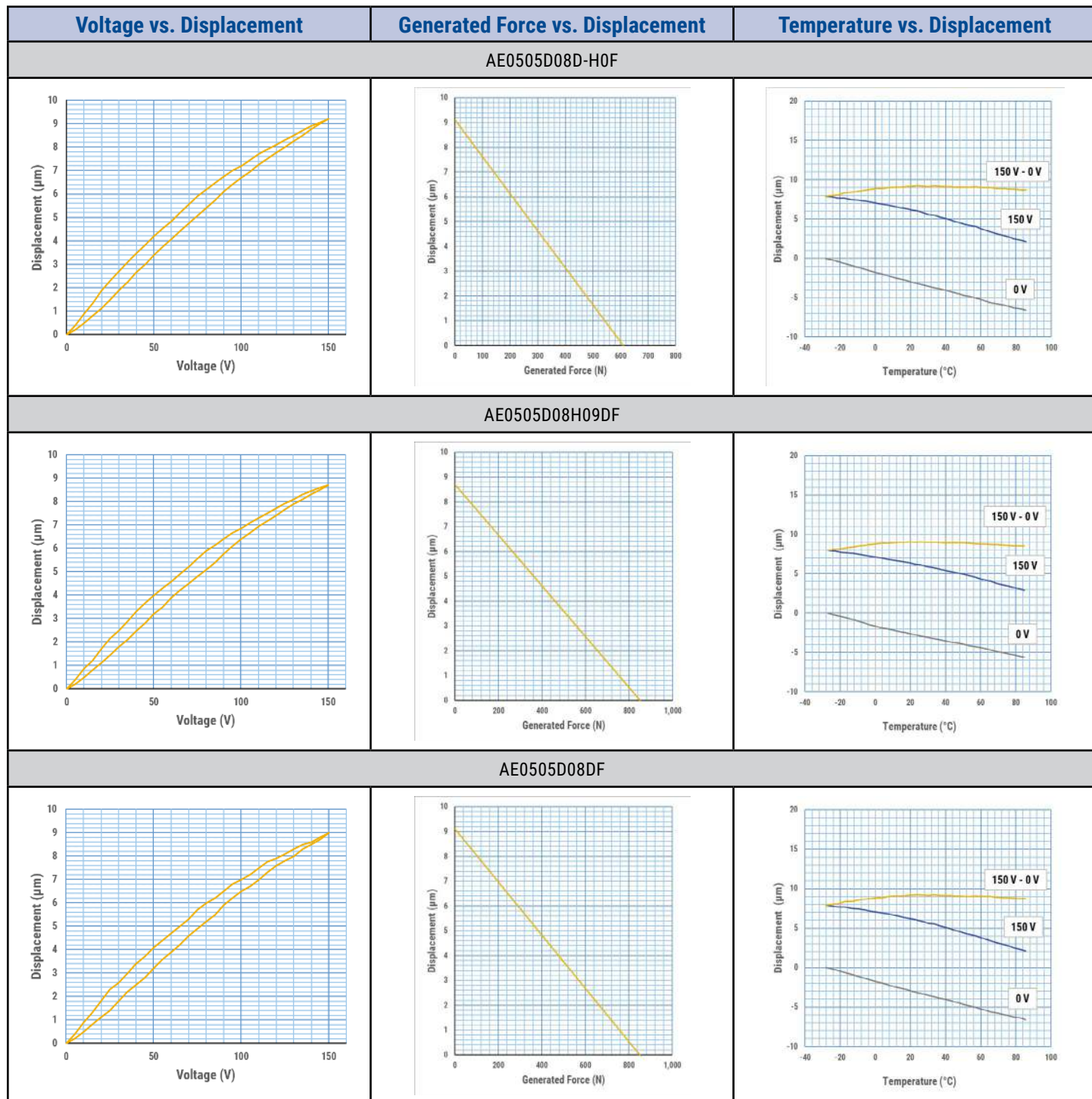

Electrical Characteristics cont.

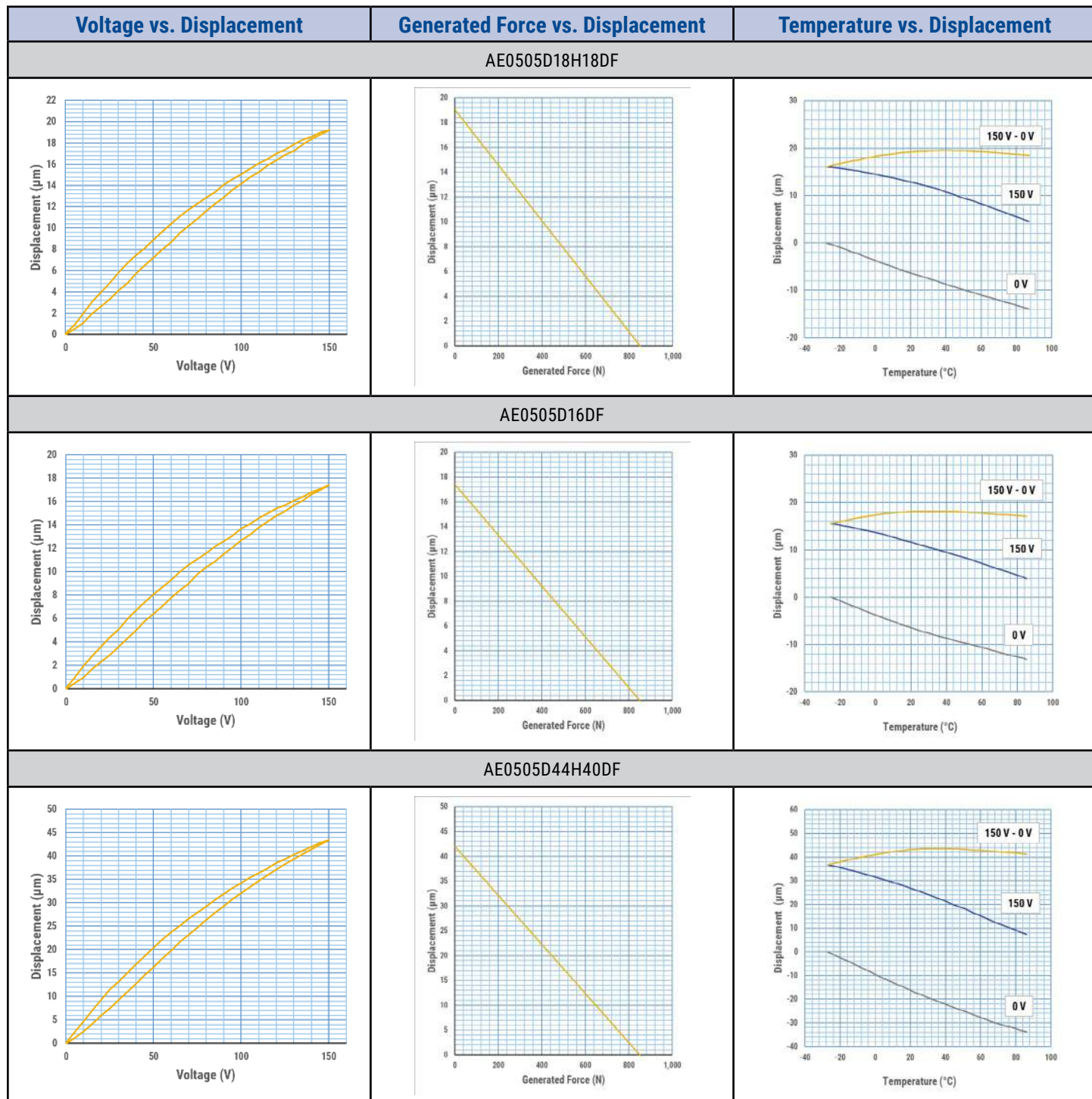

Electrical Characteristics cont.

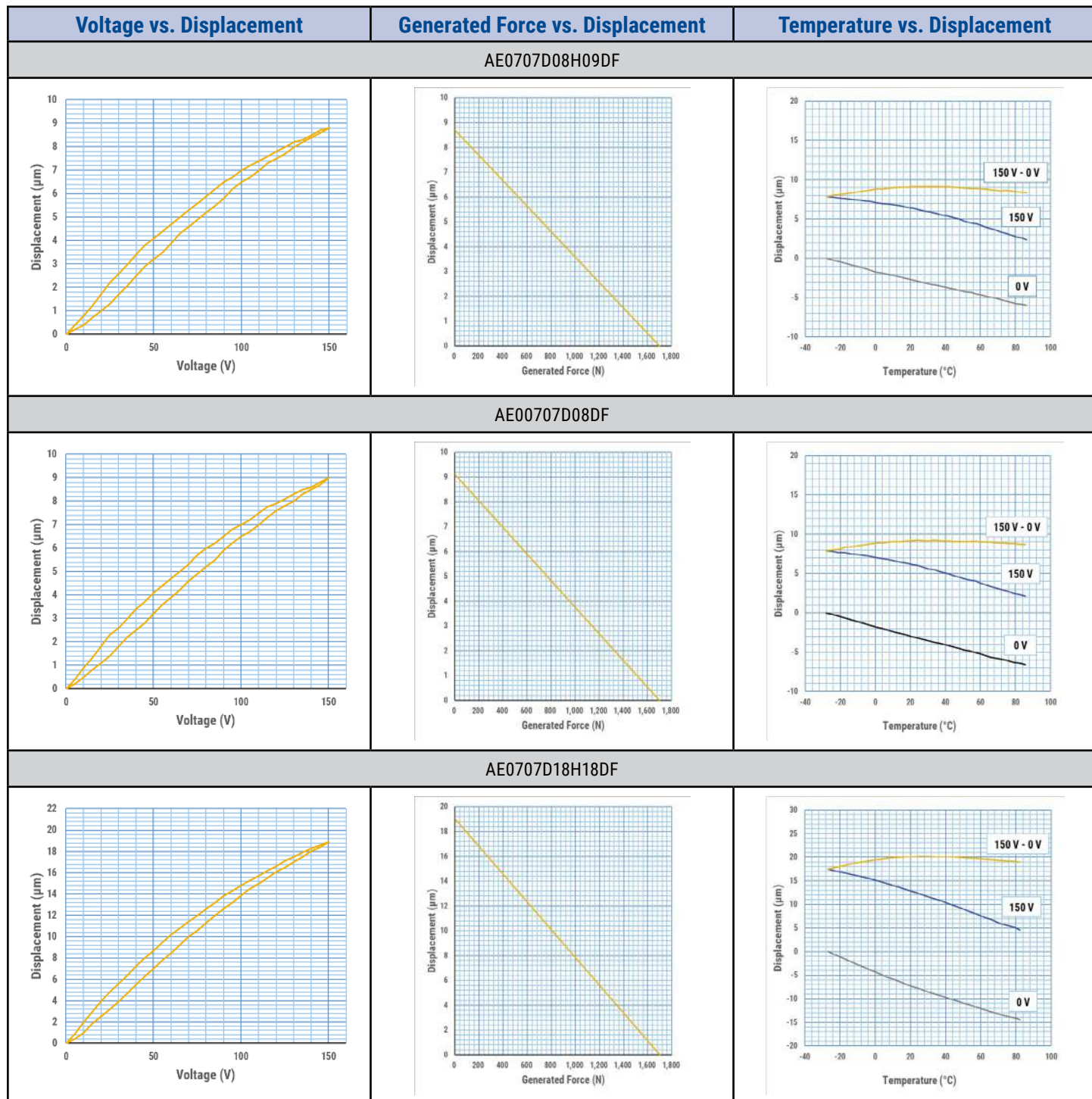

Electrical Characteristics cont.

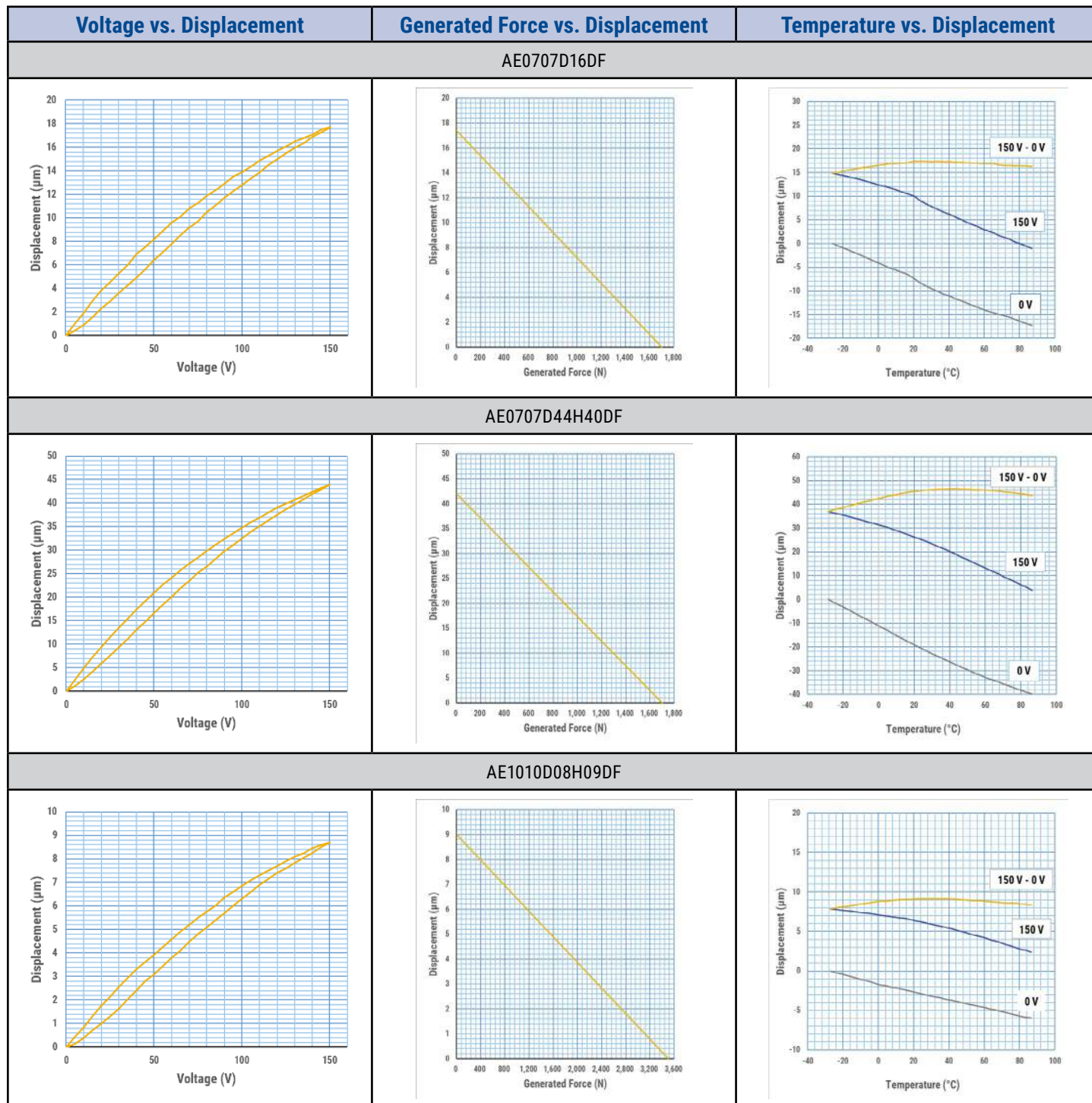

Electrical Characteristics cont.

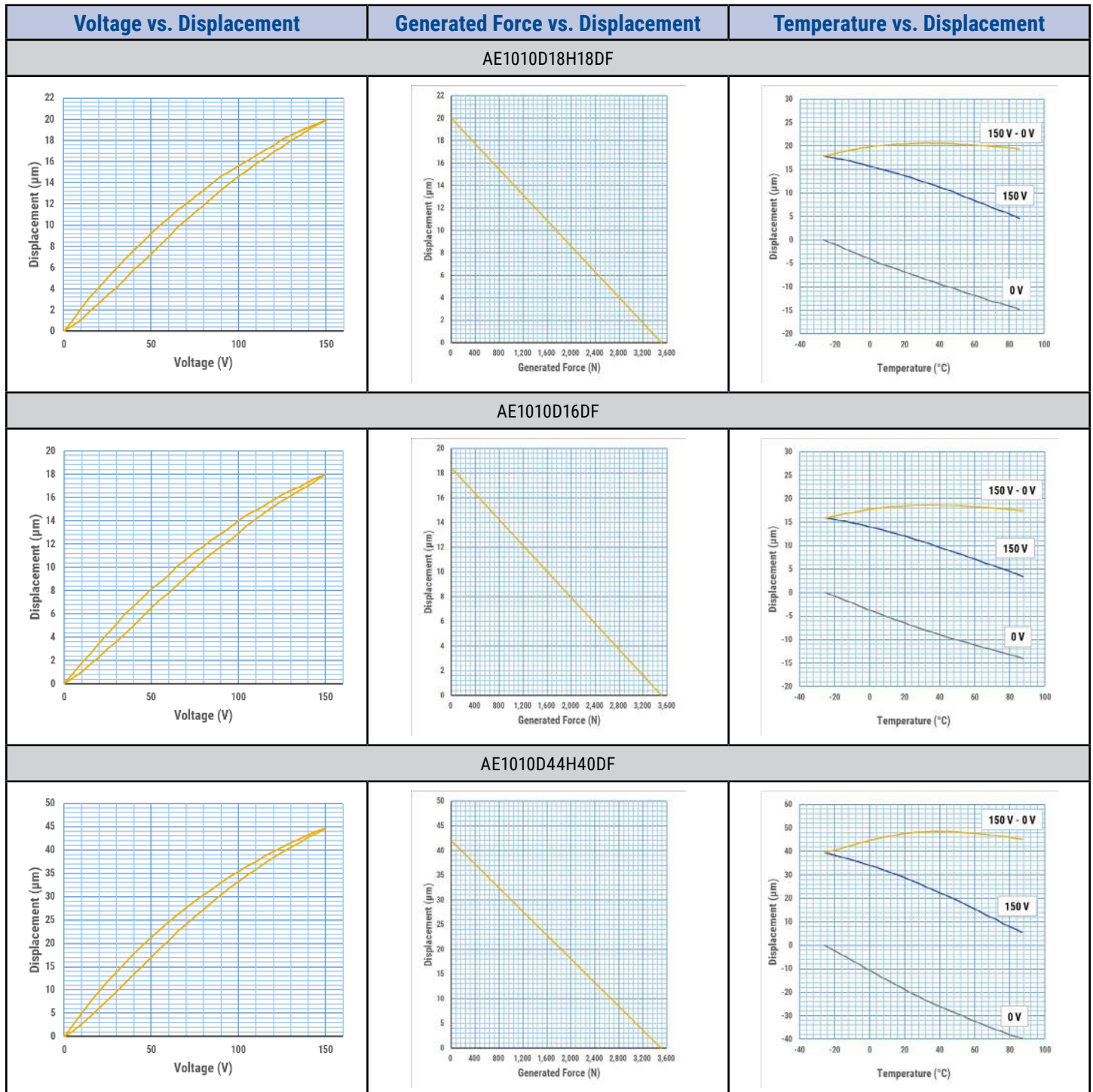

Electrical Characteristics cont.

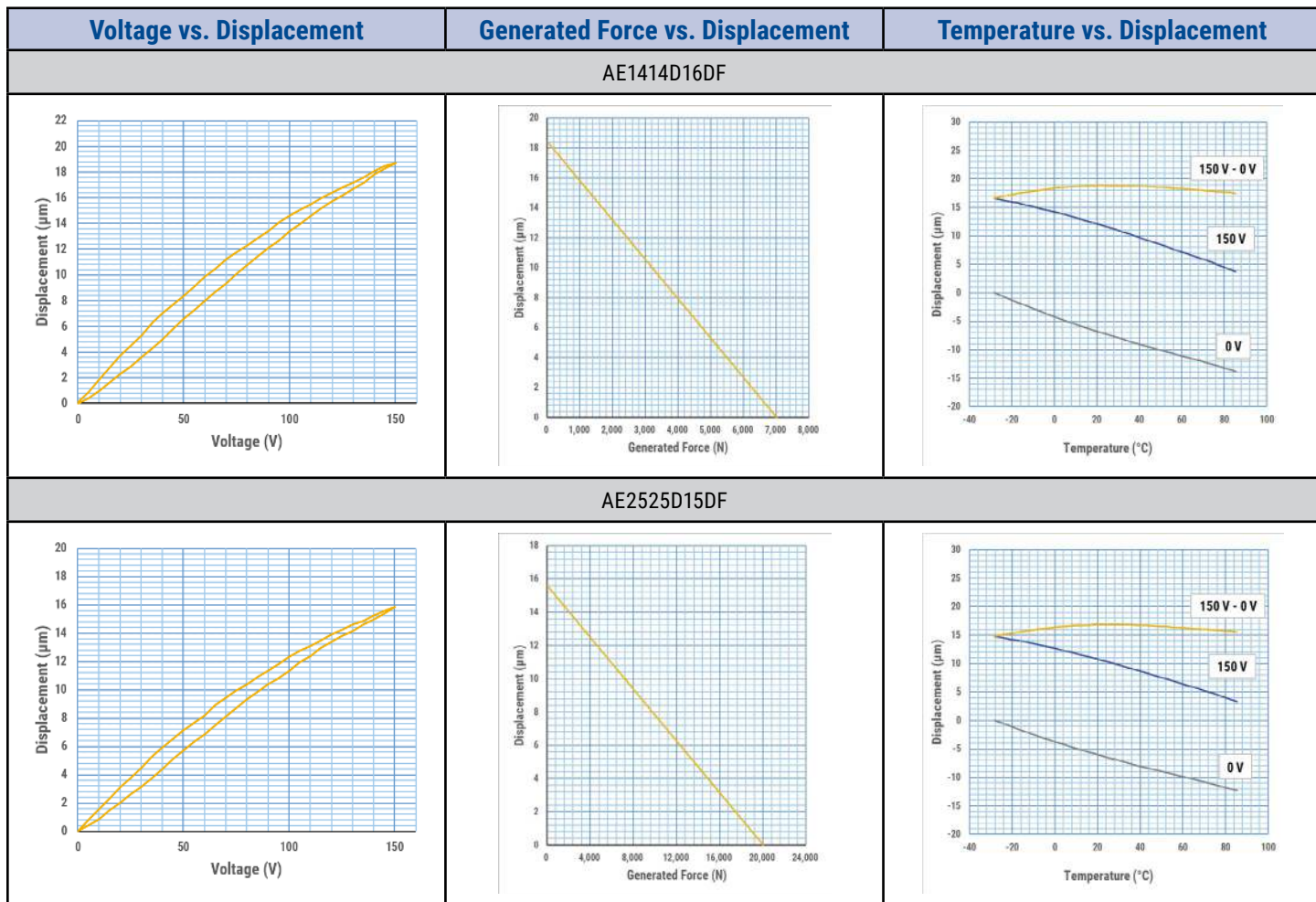

Packaging

Part Type	Packaging Type	Pieces per Box
AE0203	Bulk	10
AE035035		
AE0505		
AE0707		4
AE1010		
AE1414		1
AE2525		

Reliability

The majority of failure modes on multilayer piezoelectric actuators are short-circuits due to degraded insulation. Although the cause of degradation of insulation has not been clarified, it has been found that the failure rate varies greatly between static uses (DC voltage application) and dynamic uses (pulse voltage application). Like other electrical components, piezoelectric actuators can be affected by humidity as well as applied voltage and ambient temperature.

This section describes reliability guidelines for static and dynamic usage of the resin coated type actuators. Reliability of our multilayer piezoelectric actuators is represented by MTTf (mean time to failure) in case of static usage.

DC Voltage Application

The acceleration factors have been obtained empirically for each of the drive voltage, ambient temperature and relative humidity based on many experimental results. The MTTf_r in actual applications is estimated using equation (1) below with MTTf_s observed under accelerated conditions as the reference value.

$$(1) \text{ MTTf}_r = \text{MTTf}_s \times A_v \times A_h \times A_t$$

MTTf_r : Estimated value

MTTf_s : Reference value (= 500 hours)

A_v : Acceleration factor for drive voltage = $(150/V_r)^{3.2}$

A_h : Acceleration factor for relative humidity = $(90/H_r)^{4.9}$

A_t : Acceleration factor for ambient temperature = $1.5^{(40 - T_r)/10}$

V_r : Actual voltage (V)

H_r : Actual relative humidity (RH%)

T_r : Actual ambient temperature (°C)

The following calculation is made for the case of use at 25°C, 60% RH and 100 V.

$$\begin{aligned} \text{MTTf}_r &= 500 \times (150/100)^{3.2} \times (90/60)^{4.9} \times 1.5^{(40-25)/10} \\ &\approx 24,500 \text{ hours (2.8 years)} \end{aligned}$$

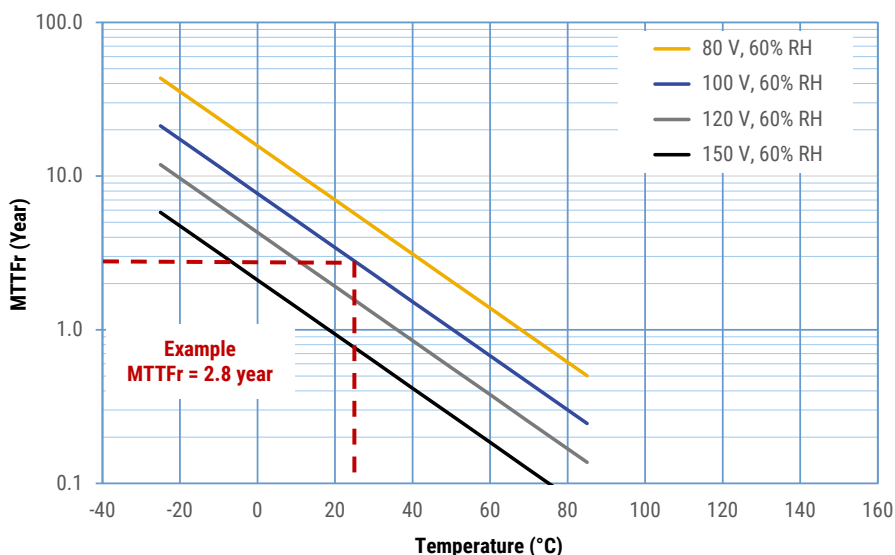

Reliability cont.

Pulse Voltage Application

In driving dynamic applications, temperature rises as a result of self-heating allowing the component not to be affected by the humidity, thus extending the operational lifetime. This phenomenon is explained as a result of the humidity factor elimination caused by the self-heating.

Since the self-heating value is affected by multiple factors such as the element's shape, pulse waveform and frequency, it is difficult to estimate the actual rising value. Therefore, the life of the actuator cannot be determined by using an equation, unlike the case of DC voltage applications. When testing the AE0203D08DF part, there was no failure confirmed after 500 hours end of the pulse driving test. (500 Hz, 0 – 150 V rectangular pulse).

Users should be careful about the influence of physical damage which can be caused by the fixing method of the element and/or the driving conditions.

User's Guide

Fixing Method

- Carefully prevent the piezoelectric actuators from being bent, twisted or applied tensile force.

Reference: Twisting and Tension Tolerance

	Reference Value	Remarks
Twisting Force	$3 \times 10^{-1} \text{ N} \cdot \text{m}$ or less	For an actuator which generates a force of 800 N (compression resistance).
Tension	50 N or less	

- Install the actuator so that the center axis of the generated displacement is aligned with the center axis of the load.
- Epoxy-based adhesives are recommended for bonding. Select adhesives that have high rigidity and allow for medium thickness so that the generation force and displacement cannot be deteriorated. Also, do not form adhesives on the side of the actuator.
- When thermosetting resin is used, perform polarizing treatment (see caution section) after the adhesive is settled.
- The resin coated type is weak to the tensile force due to its structure and may be broken when tensile forces are applied onto the device. Using the device in the state that constantly applies compression is effective against any mechanical damage. The pressure applied to this element should be kept at 20% to 50% of the force generated by this element (compression resistance).
- Install the element so that the axis of generated displacement is vertical to the mounting surface.

Example of Actuator mounting :

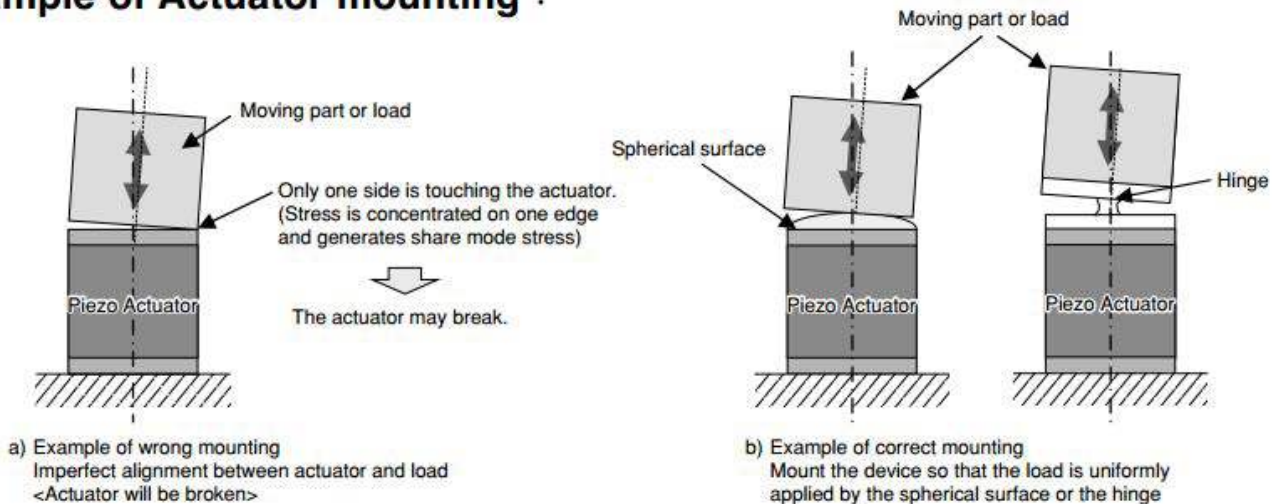

Driving Method

- Connect the red lead wire to the positive (+) terminal of the power supply. Also prevent reverse voltage application.
- In driving applications, it is necessary to take consideration of hysteresis, ringing, creep, and other similar phenomenons.
- For pulse driving, it is also necessary to be aware of self-heat generation, charge/discharge current, and the power supply's impedance.

User's Guide cont.

Generated Force and Load Relation

Static load: No load value changes when actuator moves.

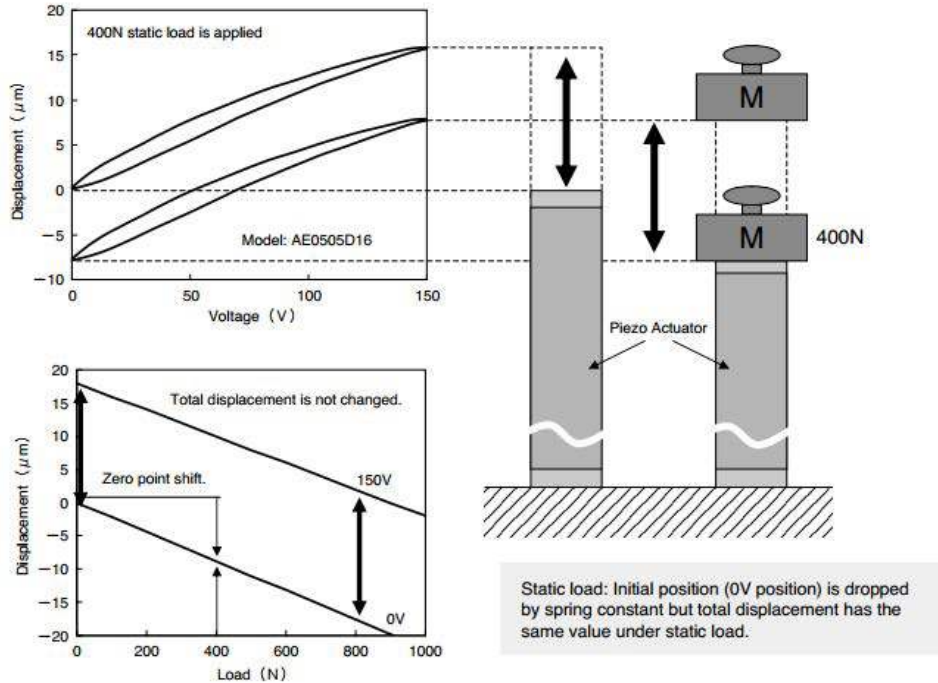

Fluctuating load: Load value changes by spring reaction when actuator moves.

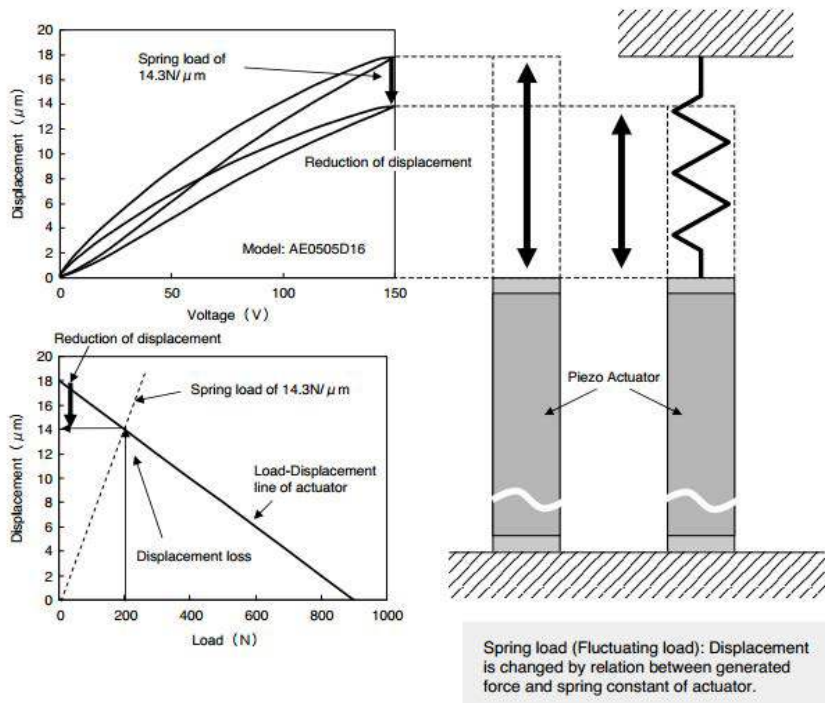

Handling Precautions

Precautions to be taken when using multilayer piezoelectric actuators (Please read these precautions before using our products)

1. Before using or designing a system using our products, read the precautions and specifications listed below.
2. The main failures with multilayer piezoelectric actuators are deterioration of insulation resistance, short-circuit and open-circuit. Before using the products, systems should be designed carefully to ensure redundancy, prevention of the spread of fire, and prevention of faulty operation allowing occurrence of failures.
3. Use the products after checking the working conditions and rated performance of each multilayer piezoelectric actuator series. Selection of AE or AER Series (resin coated type) or ASB, ASL or AHB Series (metal sealed type) should be based on the intended working temperature and humidity.

- Connect the red lead wire to the positive (+) terminal of the power supply.
- Avoid electric shocks since a high voltage is in use.
- Never apply excessive tension to a lead wire.
- Do not handle the product by picking up or moving the lead wire.
- Machining of the actuator element and replacement of the lead wire are prohibited.
- Do not handle the resin coated type (AE series) with bare hands.
- Do not wash the resin coated type (AE series) with organic solvents.
- Avoid excessive physical shock. Otherwise, the internal piezoelectric ceramic element may be damaged.
- If the actuator is exposed to high temperatures above 100°C or if used after long storage periods (more than three months), the device should be polarized by using the circuit configuration and conditions shown at right.
- Do not apply voltage exceeding maximum rating voltage, or rapid charging and discharging.
- Do not use the actuator in high concentrations of highly inflammable gas.
- Align the center axis of displacement of the actuator with the center axis of the mechanical load.
- When operated, the transient response time of the actuator should be less than 1/3 of the resonant frequency in order to prevent damage by ringing.
- Store the resin coated type preferably in a dry atmosphere (desirably below 40% RH) at ordinary temperatures (-5°C to +40°C). Avoid condensation on the product's surface.
- Store actuators where there is no vibration.
- Handle products properly as industrial waste. When disposing, please contact your local waste disposal service and make sure the disposal methods meet all legal requirements.

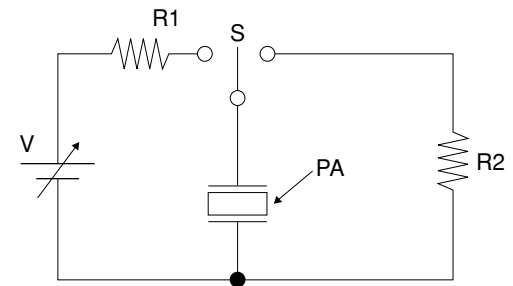

Protective resistor R1=1kΩ
Protective resistor R2=1kΩ
Polarizing conditions: DC voltage application
0V→150±0.2V (to be retained for 10 seconds) →0

Export Control

For customers in Japan

For products which are controlled items subject to the “Foreign Exchange and Foreign Trade Law” of Japan, the export license specified by the law is required for export.

For customers outside Japan

Multilayer Piezoelectric Actuators should not be used or sold for use in the development, production, stockpiling or utilization of any conventional weapons or mass-destructive weapons (nuclear weapons, chemical or biological weapons, or missiles), or any other weapons.

KEMET Electronics Corporation Sales Offices

For a complete list of our global sales offices, please visit www.kemet.com/sales.

Disclaimer

All product specifications, statements, information and data (collectively, the "Information") in this datasheet are subject to change. The customer is responsible for checking and verifying the extent to which the Information contained in this publication is applicable to an order at the time the order is placed. All Information given herein is believed to be accurate and reliable, but it is presented without guarantee, warranty, or responsibility of any kind, expressed or implied.

Statements of suitability for certain applications are based on KEMET Electronics Corporation's ("KEMET") knowledge of typical operating conditions for such applications, but are not intended to constitute – and KEMET specifically disclaims – any warranty concerning suitability for a specific customer application or use. The Information is intended for use only by customers who have the requisite experience and capability to determine the correct products for their application. Any technical advice inferred from this Information or otherwise provided by KEMET with reference to the use of KEMET's products is given gratis, and KEMET assumes no obligation or liability for the advice given or results obtained.

Although KEMET designs and manufactures its products to the most stringent quality and safety standards, given the current state of the art, isolated component failures may still occur. Accordingly, customer applications which require a high degree of reliability or safety should employ suitable designs or other safeguards (such as installation of protective circuitry or redundancies) in order to ensure that the failure of an electrical component does not result in a risk of personal injury or property damage.

Although all product-related warnings, cautions and notes must be observed, the customer should not assume that all safety measures are indicated or that other measures may not be required.

When providing KEMET products and technologies contained herein to other countries, the customer must abide by the procedures and provisions stipulated in all applicable export laws and regulations, including without limitation the International Traffic in Arms Regulations (ITAR), the US Export Administration Regulations (EAR) and the Japan Foreign Exchange and Foreign Trade Act.

KEMET is a registered trademark of KEMET Electronics Corporation.