

General Description

The AAT4626 SmartSwitch is part of Skyworks' Application Specific Power MOSFET (ASPM™) product family. It is a dual-channel 500mA current-limited P-channel MOSFET power switch designed for high-side load switching applications. This switch operates with inputs ranging from 2.7V to 5.5V, making it ideal for both

3V and 5V systems. An integrated current-limiting circuit protects the input supply against large changes in load current which may cause the supply to fall out of regulation. The AAT4626 is also protected from thermal overload which limits power dissipation and junction temperatures. The current limit threshold is factory programmed at 1.0A, with a maximum of 1.5A. The quiescent supply current is typically a low 20µA. In shutdown mode, the supply current decreases to less than 1µA.

The AAT4626 is available in a Pb-free, 8-pin SOP package and is specified over the -40°C to +85°C temperature range.

The AAT4600 series is a family of adjustable and fixed SmartSwitch products with a range of current handling capabilities. Single versions are available with adjustable current limit (AAT4601) or fixed current limit (AAT4626), as well as dual versions with fixed current limit (AAT4626).

Features

- 2.7V to 5.5V Input Voltage Range
- Compliant with USB 1.1 and 2.0 Specifications
- 500mA Minimum Continuous Current per Channel
- 1.25A Maximum Current Limit per Channel
- 90mΩ Typical $R_{DS(ON)}$
- Low Quiescent Current:
 - Typically 20µA
 - 1µA Maximum with Switch Off
- Thermal Shutdown
- Slew Rate Limited Turn On
- Fault Flag with 10ms Blanking
- Under-Voltage Lockout (UVLO)
- Temperature Range: -40°C to +85°C
- UL Approved - File No. E217765
- 8-Pin SOP or MSOP Package

Applications

- General-Purpose Power Switching
- Hot Swap Supplies
- Notebook Computers
- USB Ports and Peripherals



UL Recognized Component

Typical Application

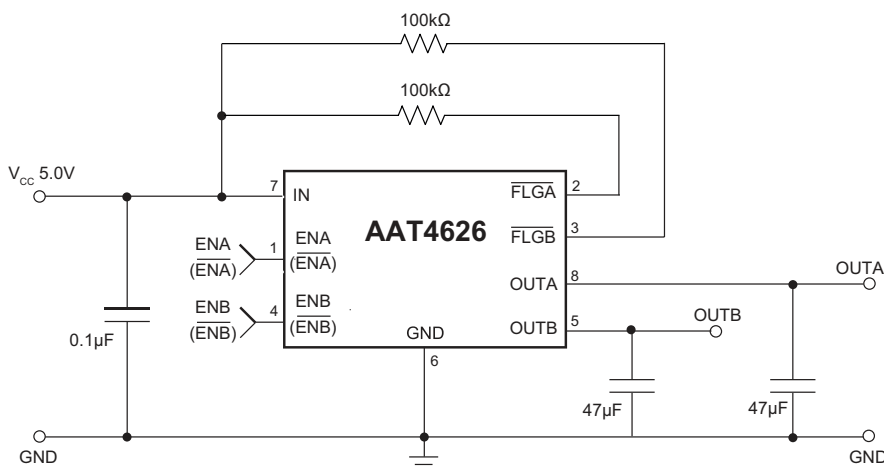

AAT4626

USB Dual-Channel Power Switch

Pin Descriptions

Pin #	Symbol	Function
1, 4	EN(A/B) ($\overline{EN(A/B)}$)	Enable inputs: logic-compatible enable input. Active high or active low option available; see Ordering Information for details.
2, 3	$\overline{FLG(A/B)}$	Fault flag outputs: active-low, open-drain output. Indicates over-current, UVLO, and thermal shutdown.
5, 8	OUT(A/B)	Switch outputs: these pins are the P-channel MOSFET drain connection.
6	GND	Ground connection.
7	IN	Supply input: this pin is the source connection for the P-channel MOSFETs. Also supplies the IC's internal circuitry.

Pin Configuration

**SOP-8
(Top View)**

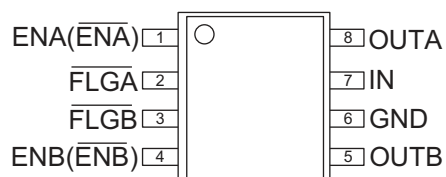

Absolute Maximum Ratings¹

Symbol	Description	Value	Units
V_{IN}	IN to GND	-0.3 to 6	V
V_{FLG}	\overline{FLGA} , \overline{FLGB} to GND	-0.3 to 6	
I_{FLG}	\overline{FLGA} , \overline{FLGB} Current	50	mA
V_{OUT}	OUTA, OUTB to GND	-0.3 to $V_{IN} + 0.3$	V
I_{OUT}	Output Current	Internally Limited	A
V_{EN}	EN (\overline{EN}) to GND	-0.3 to 6	V
T_J	Operating Junction Temperature Range	-40 to 150	°C
T_S	Storage Temperature	150	
T_{LEAD}	Maximum Soldering Temperature (at Leads)	300	

Thermal Information²

Symbol	Description	Value	Units
θ_{JA}	Maximum Thermal Resistance	100	°C/W
P_D	Maximum Power Dissipation	1.25	W

1. Stresses above those listed in Absolute Maximum Ratings may cause permanent damage to the device. Functional operation at conditions other than the operating conditions specified is not implied.

2. Mounted on an FR4 printed circuit board with 1 oz. copper ground plane.

DATA SHEET

AAT4626

USB Dual-Channel Power Switch

Electrical Characteristics

$V_{IN} = 5V$, $T_A = -40^{\circ}C$ to $+85^{\circ}C$, unless otherwise noted. Typical values are $T_A = 25^{\circ}C$; bold values designate full temperature range.

Symbol	Description	Conditions	Min	Typ	Max	Units
I_Q	Quiescent Current	$V_{IN} = 5V$, ENA and ENB Active		20	40	μA
$V_{EN-THRS}$	Enable Input Threshold	Low-to-High Transition			2.4	V
		High-to-Low Transition	0.8			
I_{EN}	Enable Input Current	$V_{EN} = 0V$ to $5.5V$		0.01	1	μA
C_{EN}	Enable Input Capacitance			1		pF
$R_{DS(ON)}$	On-Resistance	$V_{IN} = 5V$, Each Switch, $T_A = 25^{\circ}C$		90	130	m Ω
		$V_{IN} = 3.0V$, Each Switch, $T_A = 25^{\circ}C$		100	150	
T_{ON}	Output Turn-On Delay	$V_{IN} = 5V$, $R_L = 10\Omega$		0.25		ms
$T_{ON-RISE}$	Output Turn-On Rise Time	$R_L = 10\Omega$		0.2		ms
T_{OFF}	Output Turn-Off Delay	$V_{IN} = 5V$, $R_L = 10\Omega$		5	20	μs
$T_{OFF-FALL}$	Output Turn-Off Fall Time	$R_L = 10\Omega$			20	μs
$I_{SD(OFF)}$	Output Leakage Current	EN = Inactive, $V_{IN} = 5.5V$, $V_{OUT} = 0V$		0.03	1	μA
I_{LIMIT}	Current Limit Threshold	Ramped Load Applied to Enable Output, $V_{OUT} < 4.0V$	0.75	1.0	1.50	A
OTMP	Over-Temperature Shutdown	T_j Increasing		125		$^{\circ}C$
		T_j Decreasing		115		
R_{FLG}	Error Flag Output Resistance	$V_{IN} = 5V$, $I_L = 1mA$		30		Ω
I_{SINK}	Error Flag Off Current	$V_{FLG} = 5.5V$		0.05	1	μA
V_{UVLO}	Under-Voltage Lockout	$V_{IN} =$ Increasing, 1% Hysteresis	2.0	2.3	2.7	V
T_{BLANK}	FAULT Blanking			2		ms

AAT4626

USB Dual-Channel Power Switch

Typical Characteristics

$V_{IN} = 5V$, $T_A = 25^\circ C$, unless otherwise noted.

Quiescent Current vs. Temperature

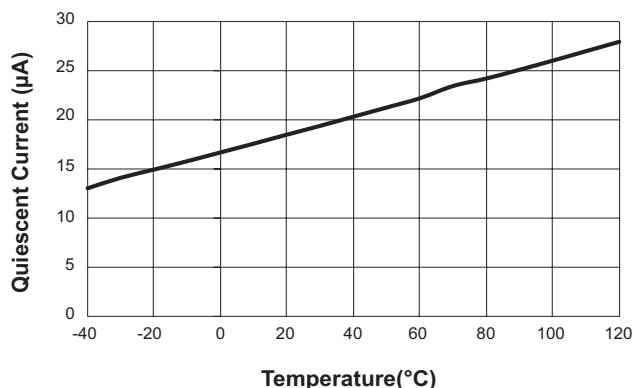

Quiescent Current

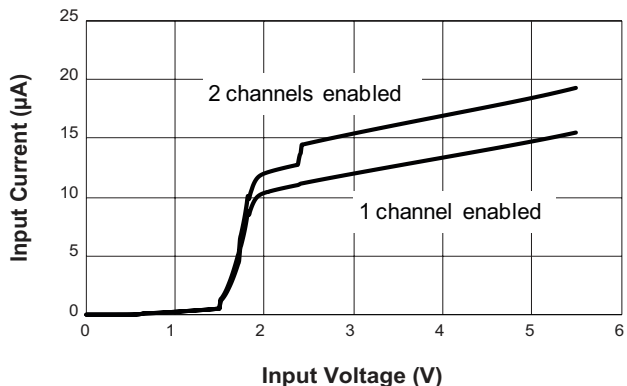

Current Limit

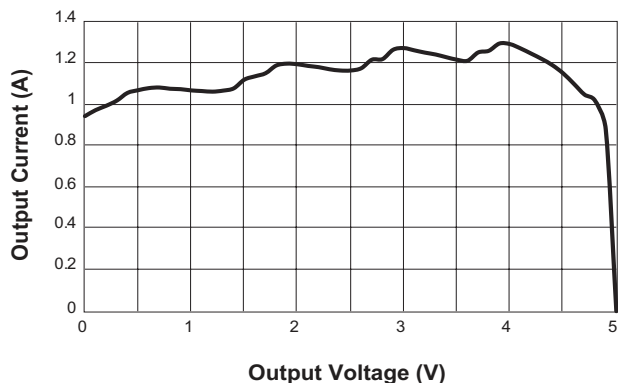

Off-Supply Current vs. Temperature

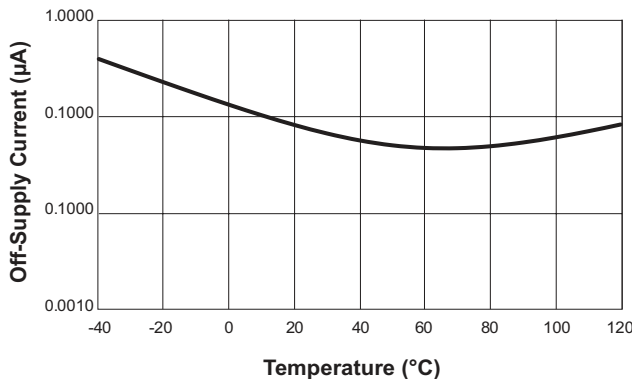

Off-Switch Current vs. temperature

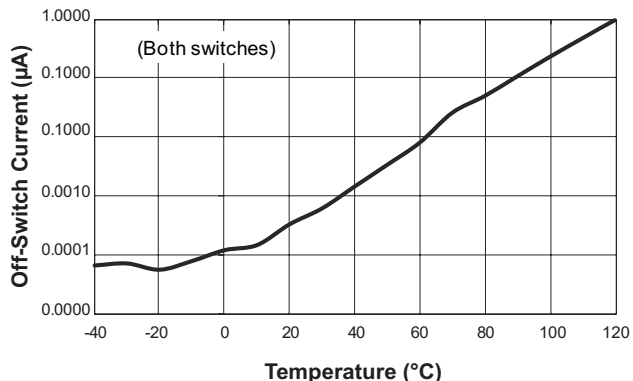

$R_{DS(ON)}$ vs. Temperature

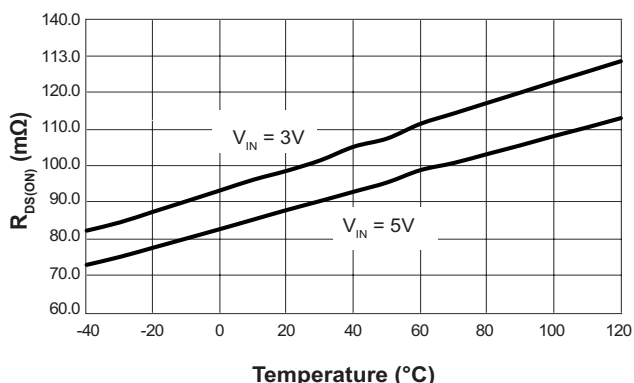

AAT4626

USB Dual-Channel Power Switch

Typical Characteristics

$V_{IN} = 5V$, $T_A = 25^\circ C$, unless otherwise noted.

Turn On/Off Response with 10Ω, 1μF Load

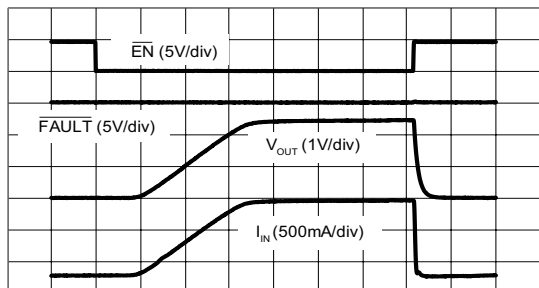

Time (100μs/div)

Start Into 1Ω Load

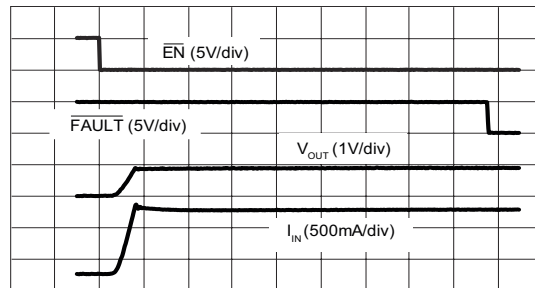

Time (1ms/div)

Thermal Shutdown Response

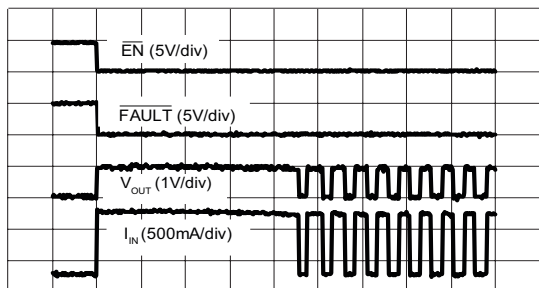

Time (100ms/div)

Short-Circuit Through 0.3Ω

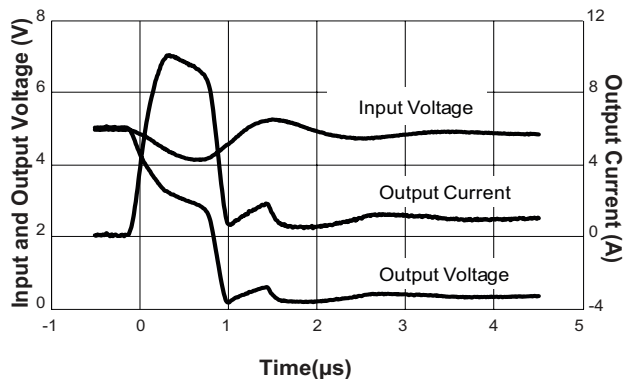

Short-Circuit Through 0.6Ω

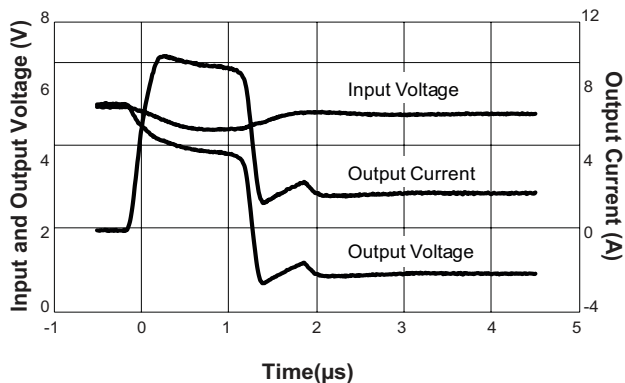

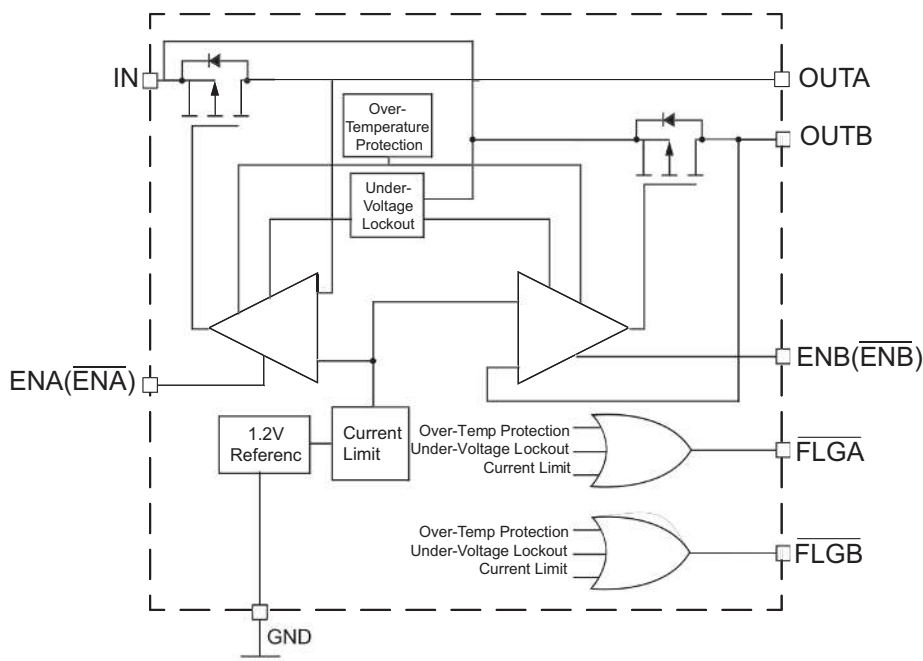
Functional Block Diagram**Functional Description**

The AAT4626 is a dual integrated MOSFET load switch with a fixed level current limit, over-temperature protection, level shifted inputs, and a fault flag for each switch. The current limit control is combined with an over-temperature thermal limit circuit to provide a comprehensive system to protect the load switch under short-circuit or other adverse operating conditions. The AAT4626 is ideally suited for control and protection of peripheral ports such as USB, RS232, and parallel ports.

The current limit and over-temperature circuits will act independently. The device current limit is activated when the output load current exceeds a preset internal threshold level. The minimum current limit threshold characteristic is specified by $I_{LIM(MIN)}$. If the load switch ambient temperature becomes excessive or if a short-circuit condition persists, the die temperature will rise, causing the over-temperature protection circuit to activate.

If the current limit or over-temperature protection circuits are active for more than ten milliseconds, the sys-

tem will be informed via the FAULT flag. The ten millisecond fault blanking delay allows the AAT4626 to be turned on into large capacitive loads without activating the FAULT flags. The open drain FAULT outputs can be connected directly to system controllers driven by voltage levels less than the IN pin voltage without additional level shifting circuitry.

Each of the two load switches is turned on and off by applying a logic level signal to the EN(A/B) pin. The AAT4626 enable function is available in both active high and active low logic level versions. The AAT4626 typically consumes $20\mu A$ when operating; when off, the device draws less than $1\mu A$. In the off state, current is prevented from flowing between the input and output on each respective channel. The EN(A/B) function has logic level thresholds that allow the AAT4626 to be TTL compatible and may also be controlled by 2.5V to 5.0V CMOS circuits. The voltage level on either EN(A/B) or FAULT(A/B) should not exceed the input supply level present on the IN pin.

Applications Information

Operation in Current Limit

If an excessive load is applied to either output of an AAT4626, the load current will be limited by the device's current limit circuitry. Refer to the "Current Limit" curve in the Typical Characteristics section of this datasheet. If a short circuit were to occur on the load applied to either the A or B output, there would be a demand for more current than what is allowed by the internal current limiting circuit and the voltage at the device output will drop. This causes the AAT4626 to dissipate more power than in normal operation, causing the die temperature to increase. When die temperature exceeds the internal over-temperature threshold, the AAT4626 will shut down both the A and B output channels. After shutting down, the AAT4626 cools to a level below the over-temperature threshold, at which point it will start up again. The AAT4626 will continue to cycle off and on until one of the following events occurs: the load current is reduced to a level below the AAT4626's current limit setting; the input power is removed; or the output is turned off by a logic high level applied to the EN pin.

Thermal Considerations

Since the AAT4626 has internal current limit and over-temperature protection, junction temperature is rarely a concern. If an application requires a large load current in a high temperature operating environment, there is the possibility that the over-temperature protection circuit rather than the current limit circuit from one of the two outputs will regulate the current available to the load. In these applications, the maximum current available without risk of activation of the over-temperature circuit can be calculated. The maximum internal temperature while current limit is not active can be calculated using Equation 1:

$$T_{J(MAX)} = I_{MAX}^2 \cdot R_{DS(ON)(MAX)} \cdot R_{\theta JA} + T_{A(MAX)}$$

In Equation 1, I_{MAX} is the maximum current required by the load. $R_{DS(ON)(MAX)}$ is the maximum rated $R_{DS(ON)}$ of the AAT4626 at high temperature. $R_{\theta JA}$ is the thermal resistance between the device die and the board onto which it is mounted. $T_{A(MAX)}$ is the maximum ambient temperature for the printed circuit board assembly under the AAT4626 when the load switch is not dissipating power. Equation 1 can be transformed to provide I_{MAX} ; Refer to Equation 2.

$$I_{MAX} = \sqrt{\frac{T_{SD(MIN)} - T_{A(MAX)}}{R_{DS(ON)(MAX)} \cdot R_{\theta JA}}}$$

$T_{SD(MIN)}$ is the minimum temperature required to activate the device over-temperature protection. The typical thermal limit temperature specification is 125°C for the AAT4626; for calculations, 115°C is a safe minimum value to use.

For example, a portable device is specified to operate in a 50°C environment. The printed circuit board assembly will operate at temperatures as high as 85°C. This portable device has a sealed case and the area of the printed board assembly is relatively small, causing $R_{\theta JA}$ to be approximately 100°C/W. $R_{DS(ON)(MAX)} = 130\text{m}\Omega$. Using Equation 2,

$$I_{MAX} = \sqrt{\frac{115^\circ\text{C} - 85^\circ\text{C}}{0.13\Omega \cdot 100^\circ\text{C/W}}} = 1.52\text{A}$$

If this system requires less than 1.52A, the thermal limit will not activate during normal operation.

Input Capacitor

The input capacitor serves two purposes. First, it protects the source power supply from transient current effects generated by the application load circuit. If a short circuit is suddenly applied to the output of an AAT4626, there is a microsecond long period during which a large current can flow before the current limit circuit becomes active. Refer to the characteristic curve "Short Circuit Through 0.3Ω." A properly sized input capacitor can dramatically reduce the load switch input transient response effects seen by the power supply and other circuitry upstream from the AAT4626.

The second purpose of the input capacitor is to prevent transient events generated by the load circuits from effecting the operation of the AAT4626. For example, if an AAT4626 is used in a circuit that operates from a 5V power supply with poor step load response, it is possible that turning on the load switch could cause the input power supply to droop below the AAT4626's under-voltage lockout threshold. This drop in voltage would cause the AAT4626 to turn off until the input power supply voltage levels recover. Since this cycle would be self-perpetuating, the entire circuit could be seen to be unstable. In the very rare case where capacitor cost is prohibitive and the input capacitor is omitted, the output load circuit should be slew rate limited when turned on.

USB Dual-Channel Power Switch**Output Capacitor**

In order to insure stability while the device current limit is active, a small capacitance of approximately $1\mu\text{F}$ should be used on each output. When either output of the AAT4626 is activated using the EN(A/B) function, there are no momentary current transients, as in the case when a short circuit is suddenly applied to a device that is already on. Refer to the Typical Characteristics curve "Turn-On/Off Response." Regardless of output capacitor size, output current on either output is limited to the value allowed by the threshold determined by the internal current limiting circuitry. Refer to the internal current limit threshold specifications stated in the Electrical Characteristics section of this datasheet. This permits very large output capacitors to be used.

For example, USB ports are specified to have at least $120\mu\text{F}$ of downstream capacitance from their controlling power switch. An output capacitance as large as $1000\mu\text{F}$ would not disturb the input power supply to an AAT4626 used to control a USB port.

EN Input

The AAT4626 has two enable inputs, ENA and ENB. These two enable inputs allow the AAT4626 to independently control each respective output. The device is available in both active high EN enable and active low (EN) enable versions. For specific part numbers, refer to the ordering information section. When both the A and B outputs of the AAT4626 are in the off state, the respective outputs are an open circuit and the device quiescent current consumption is reduced to less than $1\mu\text{A}$. The ENA and ENB threshold voltages are set to allow the AAT4626 to be controlled by 5V TTL levels, as well as CMOS-compatible levels ranging from 2.5V to 5V. The ENA or ENB function control voltage levels should not exceed the input supply level applied to the IN pin.

Fault Flag Output

The AAT4626 features an active low fault flag (FLGA and FLGB) output for each A and B output channel. The fault-flags are provided to alert the system if the over-current or over-temperature circuits become active, or if the load switch is not receiving a sufficient voltage level to properly operate. If either the current limit or over-temperature circuits in any combination are constantly active

for more than approximately ten milliseconds, the FLG(A/B) pin is pulled to ground internally through an open drain device. The 10ms delay on the fault function is intended to prevent capacitive loads connected to one of the load switch outputs from activating its respective flag when the device is turned on. The placement of a pull-up resistor between the FLGA or FLGB pin and the IN pin is recommended. Reasonable values for the pullup resistor should range from $10\text{k}\Omega$ to $100\text{k}\Omega$. Since the fault flags are open drain terminals, they may be pulled up to any voltage that is not greater than the level present on the IN pin. This is done to allow the AAT4626 to signal ancillary circuitry that is powered by voltage levels less than the level on the IN pin.

If a fault flag delay greater than 10ms is required, addition delay may be added by use of an RC filter. As shown in Figure 1, an RC filter can be added to the fault flag output.

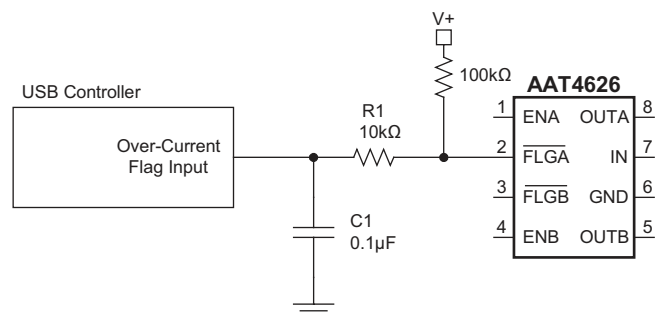

Figure 1: Fault Flag Delay RC Filter.

Reverse Voltage

The AAT4626 is designed to control current flowing from IN to OUT. If a voltage is applied to OUT which is greater than that on IN, a large resulting reverse current may flow, potentially damaging the AAT4626.

Under-Voltage Lockout

The AAT4626 has been designed with an under-voltage lockout control circuit. The under-voltage lockout prevents the output MOSFET devices from turning on until V_{IN} exceeds the typical UVLO threshold of 2.3V. During operation, the device will automatically shut down if V_{IN} falls below the UVLO threshold and the fault flags will be toggled.

USB Dual-Channel Power Switch**Hot-Plug Applications**

Application circuit cards with a high inrush current potential can be limited by use of the AAT4626. The AAT4626 has both slew rate limited turn on characteristics and current limit controlled outputs, which make it ideally suited for power port hot-plug applications. A host power back plane or hot-plug receptacle may be sensitive to short duration, high power surges. The AAT4626 will turn on in a linear ramping fashion and regulate the inrush current within the specified current limit for the device. The error flag usually will not be affected during application turn-on since the 10ms fault flag blanking time is intended for these types of events. If an application turn-on current surge exceeds 10ms, an RC delay filter may be added to the flag output to prevent the system from receiving an error during the start-up sequence.

PCB Layout Information

In order to obtain the maximum performance from the AAT4626, very careful attention must be considered in regard to the printed circuit board layout. In most port power switch and port protection applications, high voltage and current transient events will occur. Proper PCB layout can help reduce the effects of transient events. PCB trace resistance will effect overall circuit transient response; small voltage drops will also be incurred.

Refer to the following guidelines for power port PCB layout:

1. PCB traces should be kept as short and direct as possible to minimize the effects of the PCB on circuit performance.
2. Make component solder pads large to minimize contact resistance.
3. The AAT4626 output bulk capacitors and ferrite beads should be placed as close to the device as possible. PCB traces to the output connector should be kept as short as possible to minimized trace resistance and the associated voltage drop (I^2R loss).
4. If ferrite beads are used in the circuit, select ferrite beads with a minimum series resistance.
5. The use of PCB trace vias should be avoided on all traces that conduct high currents. If vias are necessary, make the vias as large as possible and use multiple vias connected in parallel to minimize their effect.

Evaluation Board Layout

The AAT4626 evaluation layout follows the recommend printed circuit board layout procedures and can be used as an example for good application layouts. (See Figures 4, 5, and 6.) Note that ferrite beads are not used on this simple device evaluation board. The board layout shown is not to scale.

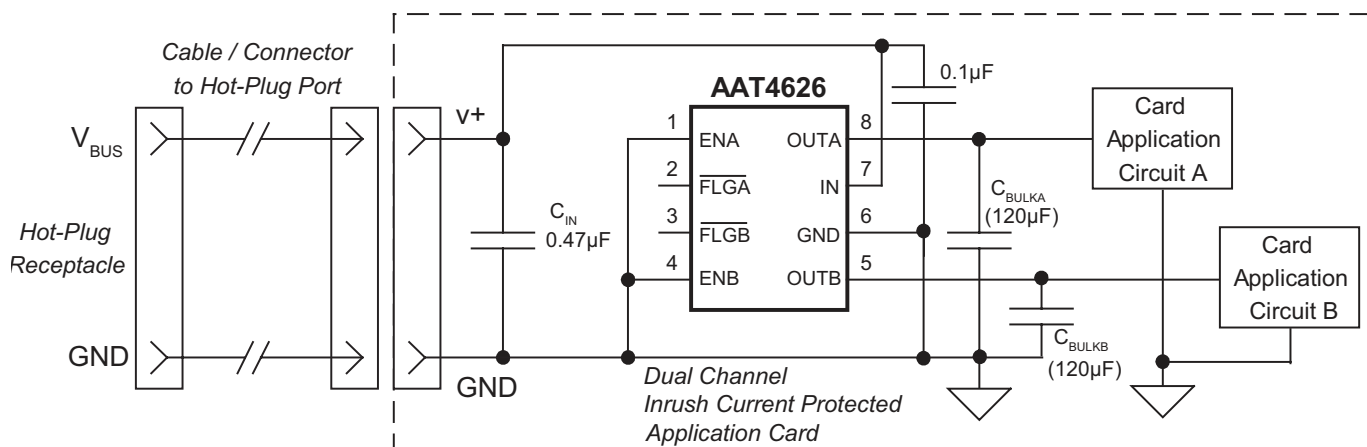

Figure 2: AAT4626 Input Inrush Current Protected Dual Output Application.

AAT4626

USB Dual-Channel Power Switch

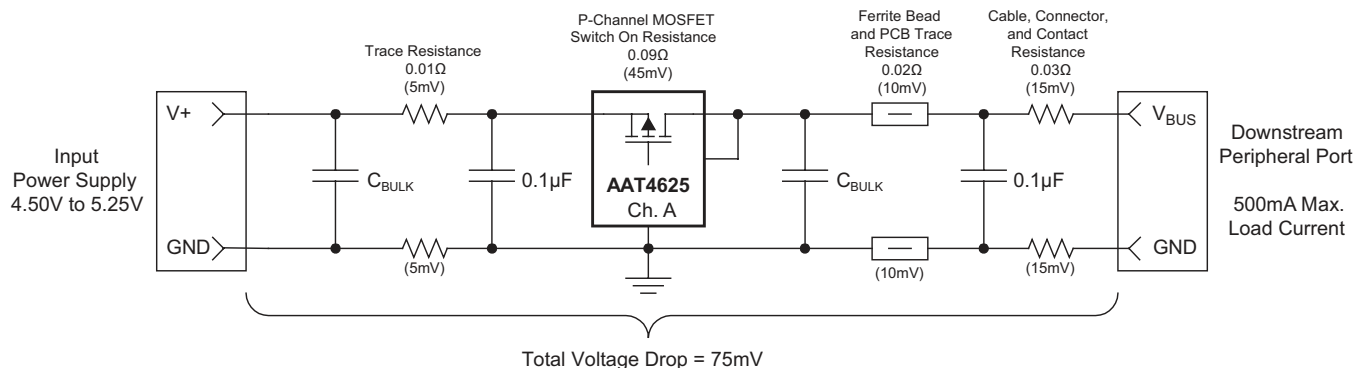

Figure 3: Summary of Typical Circuit Voltage Drops Caused by AAT4626 Circuit Components and PCB Trace Resistance.

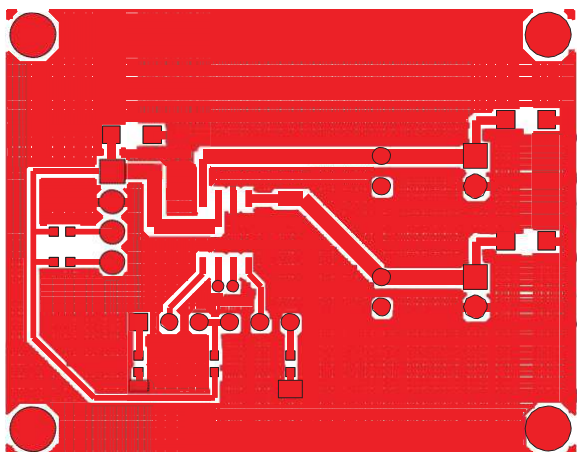

Figure 4: AAT4626 Evaluation Board Component Side Layout.

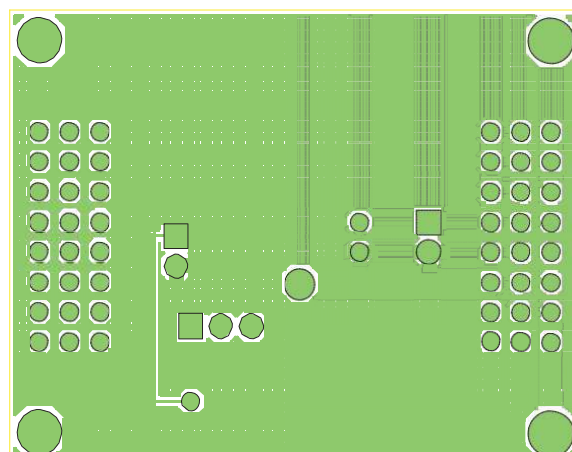

Figure 5: AAT4626 Evaluation Board Solder Side Layout.

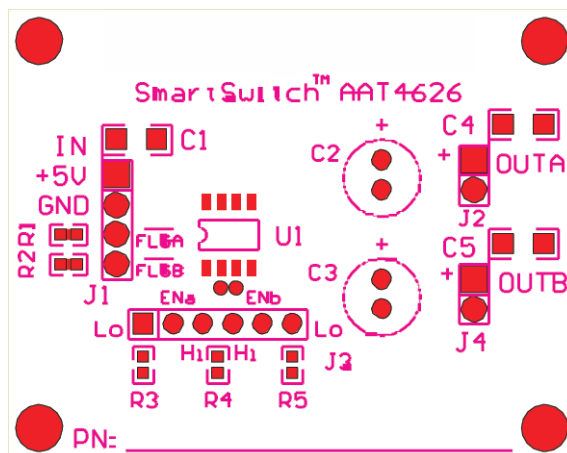

Figure 6: AAT4626 Evaluation Board Top Side Silk Screen Layout/Assembly Drawing.

AAT4626

USB Dual-Channel Power Switch

Application Circuits

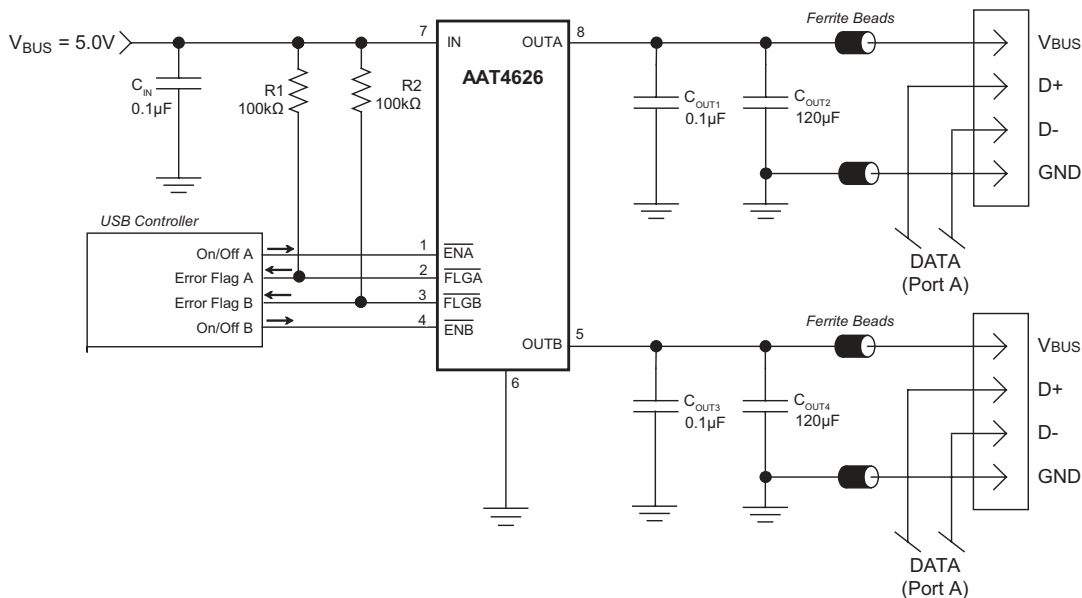

Figure 7: Typical USB Host Port Application.

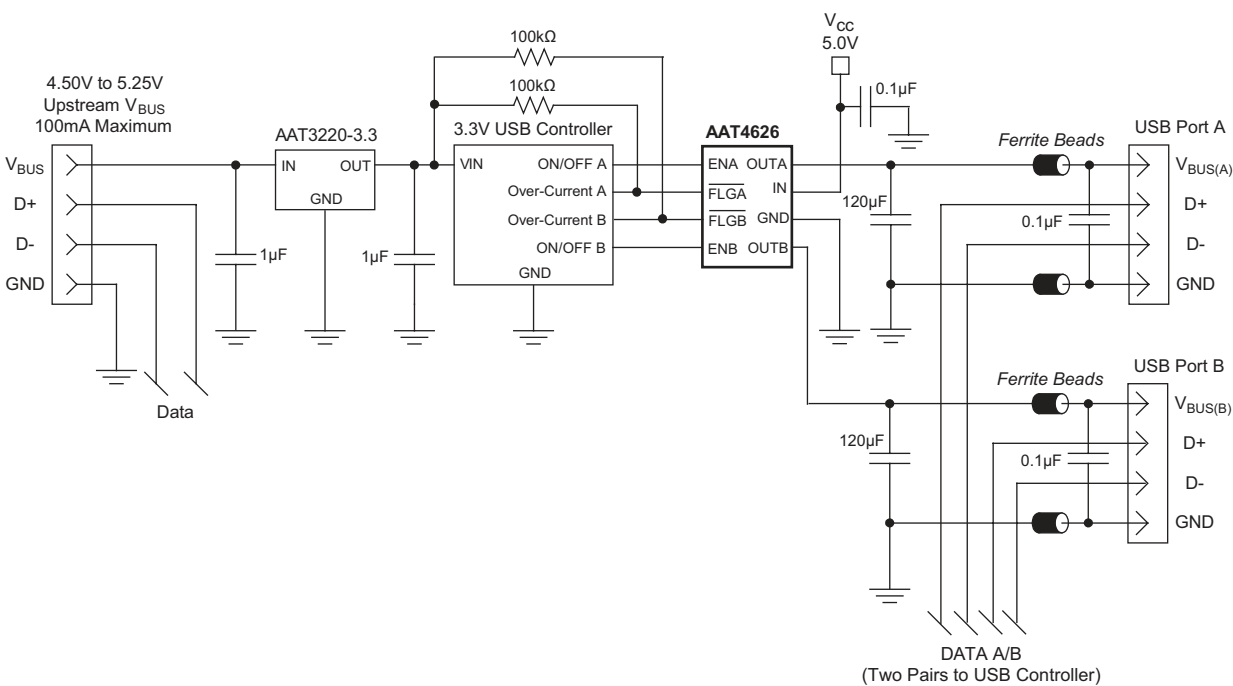

Figure 8: Self-Powered Single Port USB Hub.

AAT4626

USB Dual-Channel Power Switch

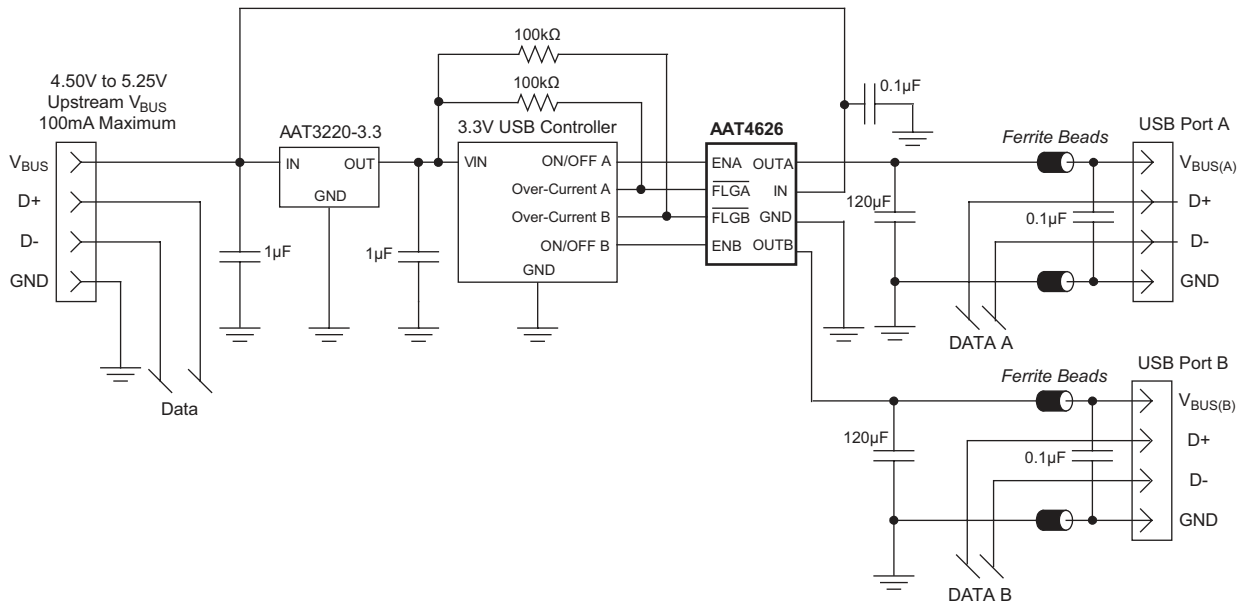



Figure 9: USB Bus Powered Single Port USB Hub.

AAT4626

USB Dual-Channel Power Switch

Ordering Information

Package	Enable	Marking ¹	Part Number (Tape and Reel) ²
SOP-8	EN (Active-high)	4626-1	AAT4626IAS-1-T1
SOP-8	EN (Active-low)	4626	AAT4626IAS-T1

 Skyworks Green™ products are compliant with all applicable legislation and are halogen-free. For additional information, refer to *Skyworks Definition of Green™*, document number SQ04-0074.

Package Information

SOP-8

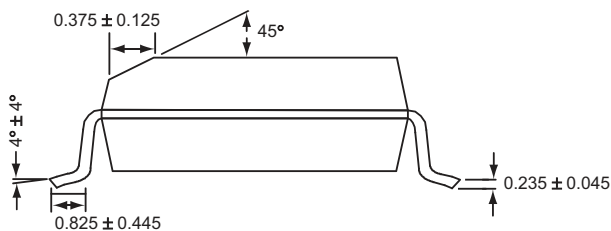
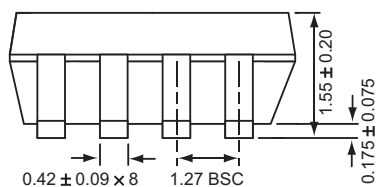
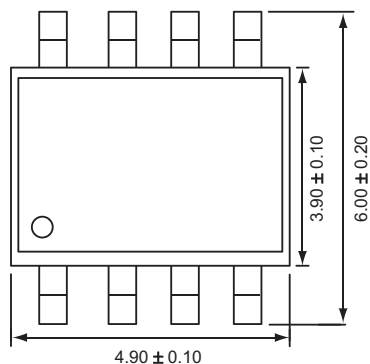

All dimensions in millimeters.

1. XYY = assembly and date code.
 2. Sample stock is generally held on part numbers listed in **BOLD**.

Copyright © 2012 Skyworks Solutions, Inc. All Rights Reserved.

Information in this document is provided in connection with Skyworks Solutions, Inc. ("Skyworks") products or services. These materials, including the information contained herein, are provided by Skyworks as a service to its customers and may be used for informational purposes only by the customer. Skyworks assumes no responsibility for errors or omissions in these materials or the information contained herein. Skyworks may change its documentation, products, services, specifications or product descriptions at any time, without notice. Skyworks makes no commitment to update the materials or information and shall have no responsibility whatsoever for conflicts, incompatibilities, or other difficulties arising from any future changes.

No license, whether express, implied, by estoppel or otherwise, is granted to any intellectual property rights by this document. Skyworks assumes no liability for any materials, products or information provided hereunder, including the sale, distribution, reproduction or use of Skyworks products, information or materials, except as may be provided in Skyworks Terms and Conditions of Sale.

THE MATERIALS, PRODUCTS AND INFORMATION ARE PROVIDED "AS IS" WITHOUT WARRANTY OF ANY KIND, WHETHER EXPRESS, IMPLIED, STATUTORY, OR OTHERWISE, INCLUDING FITNESS FOR A PARTICULAR PURPOSE OR USE, MERCHANTABILITY, PERFORMANCE, QUALITY OR NON-INFRINGEMENT OF ANY INTELLECTUAL PROPERTY RIGHT; ALL SUCH WARRANTIES ARE HEREBY EXPRESSLY DISCLAIMED. SKYWORKS DOES NOT WARRANT THE ACCURACY OR COMPLETENESS OF THE INFORMATION, TEXT, GRAPHICS OR OTHER ITEMS CONTAINED WITHIN THESE MATERIALS. SKYWORKS SHALL NOT BE LIABLE FOR ANY DAMAGES, INCLUDING BUT NOT LIMITED TO ANY SPECIAL, INDIRECT, INCIDENTAL, STATUTORY, OR CONSEQUENTIAL DAMAGES, INCLUDING WITHOUT LIMITATION, LOST REVENUES OR LOST PROFITS THAT MAY RESULT FROM THE USE OF THE MATERIALS OR INFORMATION, WHETHER OR NOT THE RECIPIENT OF MATERIALS HAS BEEN ADVISED OF THE POSSIBILITY OF SUCH DAMAGE.

Skyworks products are not intended for use in medical, lifesaving or life-sustaining applications, or other equipment in which the failure of the Skyworks products could lead to personal injury, death, physical or environmental damage. Skyworks customers using or selling Skyworks products for use in such applications do so at their own risk and agree to fully indemnify Skyworks for any damages resulting from such improper use or sale.

Customers are responsible for their products and applications using Skyworks products, which may deviate from published specifications as a result of design defects, errors, or operation of products outside of published parameters or design specifications. Customers should include design and operating safeguards to minimize these and other risks. Skyworks assumes no liability for applications assistance, customer product design, or damage to any equipment resulting from the use of Skyworks products outside of stated published specifications or parameters.

Skyworks, the Skyworks symbol, and "Breakthrough Simplicity" are trademarks or registered trademarks of Skyworks Solutions, Inc., in the United States and other countries. Third-party brands and names are for identification purposes only, and are the property of their respective owners. Additional information, including relevant terms and conditions, posted at www.skyworksinc.com, are incorporated by reference.