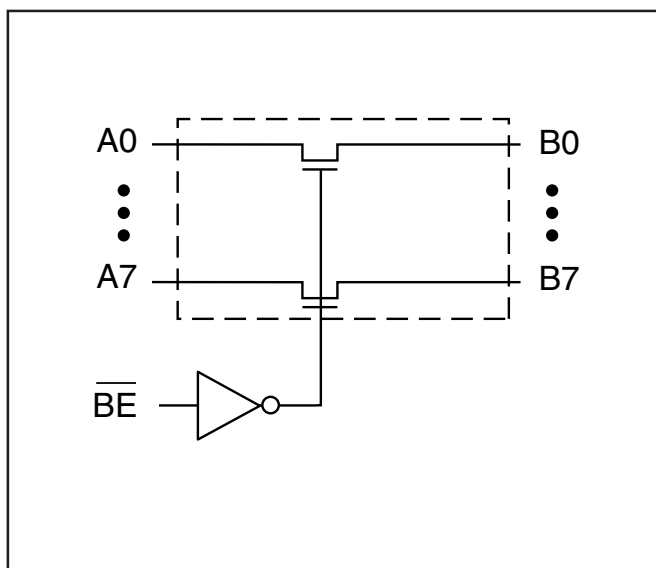
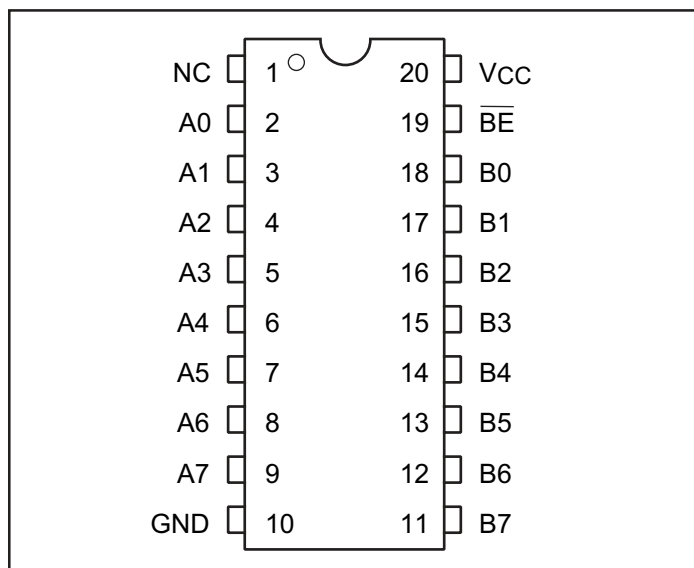

**2.5V/3.3V, High Bandwidth, Hot Insertion  
8-Bit, 2-Port, Bus Switch**
**Features**

- Near-Zero propagation delay
- 5-ohm switches connect inputs to outputs
- High Bandwidth Operation (>400 MHz)
- Permits Hot Insertion
- 5VI/O Tolerant
- Rail-to-Rail 3.3V or 2.5V Switching
- 2.5V Supply Voltage Operation
- Packaging (Pb-free & Green available):
  - 20-pin 150 mil wide plastic QSOP (Q)
  - 20-pin 173 mil wide plastic TSSOP (L)

**Description**

Pericom Semiconductor's PI3C3245 is a 2.5 volt or 3.3 volt 8-bit, 2-port bus switch designed with a low On-Resistance (5-ohm) allowing inputs to be connected directly to outputs. The bus switch creates no additional propagational delay or additional ground bounce noise. The switches are turned ON by the Bus Enable ( $\overline{BE}$ ) input signal. It is very useful in switching signals that have high bandwidth (>400 MHz).

**Block Diagram**

**Pin Configuration**

**Truth Table<sup>(1)</sup>**

Function	$\overline{BE}$	A0-7
Disconnect	H	Hi-Z
Connect	L	B0-7

**Note:**

1. H = High Voltage Level  
L = Low Voltage Level  
Hi-Z = High Impedance

**Pin Description**

Pin Name	Description
$\overline{BE}$	Bus Enable Input (Active LOW)
A0-7	Bus A
B0-7	Bus B
GND	Ground
VCC	Power

### Maximum Ratings

(Above which the useful life may be impaired. For user guidelines, not tested.)

Storage Temperature .....	-65°C to +150°C
Ambient Temperature with Power Applied .....	-40°C to +85°C
Supply Voltage to Ground Potential (Inputs & V <sub>CC</sub> Only) .....	-0.5V to +4.6V
Supply Voltage to Ground Potential (Outputs & D/O Only) .....	-0.5V to +4.6V
DC Input Voltage .....	-0.5V to +5.5V
DC Output Current .....	120mA
Power Dissipation .....	0.5W

**Note:**

Stresses greater than those listed under MAXIMUM RATINGS may cause permanent damage to the device. This is a stress rating only and functional operation of the device at these or any other conditions above those indicated in the operational sections of this specification is not implied. Exposure to absolute maximum rating conditions for extended periods may affect reliability.

### DC Electrical Characteristics (Over Operating Range, T<sub>A</sub> = -40°C to +85°C, V<sub>CC</sub> = 3.3V ±10%)

Parameters	Description	Test Conditions <sup>(1)</sup>	Min.	Typ. <sup>(2)</sup>	Max.	Units
V <sub>IH</sub>	Input HIGH Voltage	Guaranteed Logic HIGH Level	2.0			V
V <sub>IL</sub>	Input LOW Voltage	Guaranteed Logic LOW Level	-0.5		0.8	
I <sub>IH</sub>	Input HIGH Current	V <sub>CC</sub> = Max., V <sub>IN</sub> = V <sub>CC</sub>			±1	μA
I <sub>IL</sub>	Input LOW Current	V <sub>CC</sub> = Max., V <sub>IN</sub> = GND			±1	
I <sub>OZH</sub> <sup>(3)</sup>	High Impedance Output Current	0 ≤ A, B ≤ V <sub>CC</sub>			±1	
V <sub>IK</sub>	Clamp Diode Voltage	V <sub>CC</sub> = Min., I <sub>IN</sub> = -18mA	-0.73	-1.2		V
R <sub>ON</sub>	Switch On Resistance <sup>(4)</sup>	V <sub>CC</sub> = Min., V <sub>IN</sub> = 0.0V, I <sub>ON</sub> = 48mA V <sub>CC</sub> = Min., V <sub>IN</sub> = 2.4V, I <sub>ON</sub> = 15mA		5 8	7 15	Ω

**Notes:**

1. For Max. or Min. conditions, use appropriate value specified under Electrical Characteristics for the applicable device type.
2. Typical values are at V<sub>CC</sub> = 3.3V, T<sub>A</sub> = 25°C ambient and maximum loading.
3. Not more than one output should be shorted at one time. Duration of the test should not exceed one second.
4. Measured by the voltage drop between A and B pin at indicated current through the switch. ON resistance is determined by the lower of the voltages on the two (A,B) pins.

### Capacitance (T<sub>A</sub> = 25°C, f = 1 MHz)

Parameters <sup>(1)</sup>	Description	Test Conditions	Typ.	Units
C <sub>IN</sub>	Input Capacitance	V <sub>IN</sub> = 0V	3.5	
C <sub>OFF</sub>	A/B Capacitance, Switch Off	V <sub>IN</sub> = 0V	5.0	pF
C <sub>ON</sub>	A/B Capacitance, Switch On	V <sub>IN</sub> = 0V	10.0	

**Notes:**

1. This parameter is determined by device characterization but is not production tested.

### Power Supply Characteristics

Parameters	Description	Test Conditions <sup>(1)</sup>		Min.	Typ. <sup>(2)</sup>	Max.	Units
I <sub>CC</sub>	Quiescent Power Supply Current	V <sub>CC</sub> = Max.	V <sub>IN</sub> = GND or V <sub>CC</sub>		260	500	μA
ΔI <sub>CC</sub>	Supply Current per Input HIGH	V <sub>CC</sub> = Max.	V <sub>IN</sub> = 3.0V <sup>(3)</sup>			750	

**Notes:**

1. For Max. or Min. conditions, use appropriate value specified under Electrical Characteristics for the applicable device.
2. Typical values are at V<sub>CC</sub> = 3.3V, +25°C ambient.
3. Per driven input (control input only); A and B pins do not contribute to ΔI<sub>CC</sub>.

### Switching Characteristics over 3.3V Operating Range

Parameters	Description	Conditions	PI3C3245		Units
			Com.		
			Min.	Max.	
t <sub>PLH</sub> t <sub>PHL</sub>	Propagation Delay <sup>(1,2)</sup> Ax to Bx	C <sub>L</sub> = 50pF R <sub>L</sub> = 500-ohm		0.25	ns
t <sub>PZH</sub> t <sub>PZL</sub>	Bus Enable Time BE to Ax or Bx	C <sub>L</sub> = 50pF	1.5	6.5	
t <sub>PHZ</sub> t <sub>PLZ</sub>	Bus Disable Time BE to Ax or Bx	R <sub>L</sub> = 500-ohm R = 500-ohm	1.5	5.5	

**Notes:**

1. This parameter is guaranteed but not tested on Propagation Delays.
2. The bus switch contributes no propagational delay other than the RC delay of the ON resistance of the switch and the load capacitance. The time constant for the switch alone is of the order of 0.25ns for 50pF load. Since this time constant is much smaller than the rise/fall times of typical driving signals, it adds very little propagational delay to the system. Propagational delay of the bus switch when used in a system is determined by the driving circuit on the driving side of the switch and its interaction with the load on the driven side.

### Switching Characteristics over 2.5V Operating Range

Parameters	Description	Conditions	PI3C3245		Units
			Com.		
			Min.	Max.	
t <sub>PLH</sub> t <sub>PHL</sub>	Propagation Delay <sup>(1,2)</sup> Ax to Bx	C <sub>L</sub> = 50pF R <sub>L</sub> = 500-ohm		0.25	ns
t <sub>PZH</sub> t <sub>PZL</sub>	Bus Enable Time BE to Ax or Bx	C <sub>L</sub> = 50pF	1.5	9.8	
t <sub>PHZ</sub> t <sub>PLZ</sub>	Bus Disable Time BE to Ax or Bx	R <sub>L</sub> = 500-ohm R = 500-ohm	1.5	8.3	

**Notes:**

1. This parameter is guaranteed but not tested on Propagation Delays.
2. The bus switch contributes no propagational delay other than the RC delay of the ON resistance of the switch and the load capacitance. The time constant for the switch alone is of the order of 0.25ns for 50pF load. Since this time constant is much smaller than the rise/fall times of typical driving signals, it adds very little propagational delay to the system. Propagational delay of the bus switch when used in a system is determined by the driving circuit on the driving side of the switch and its interaction with the load on the driven side.

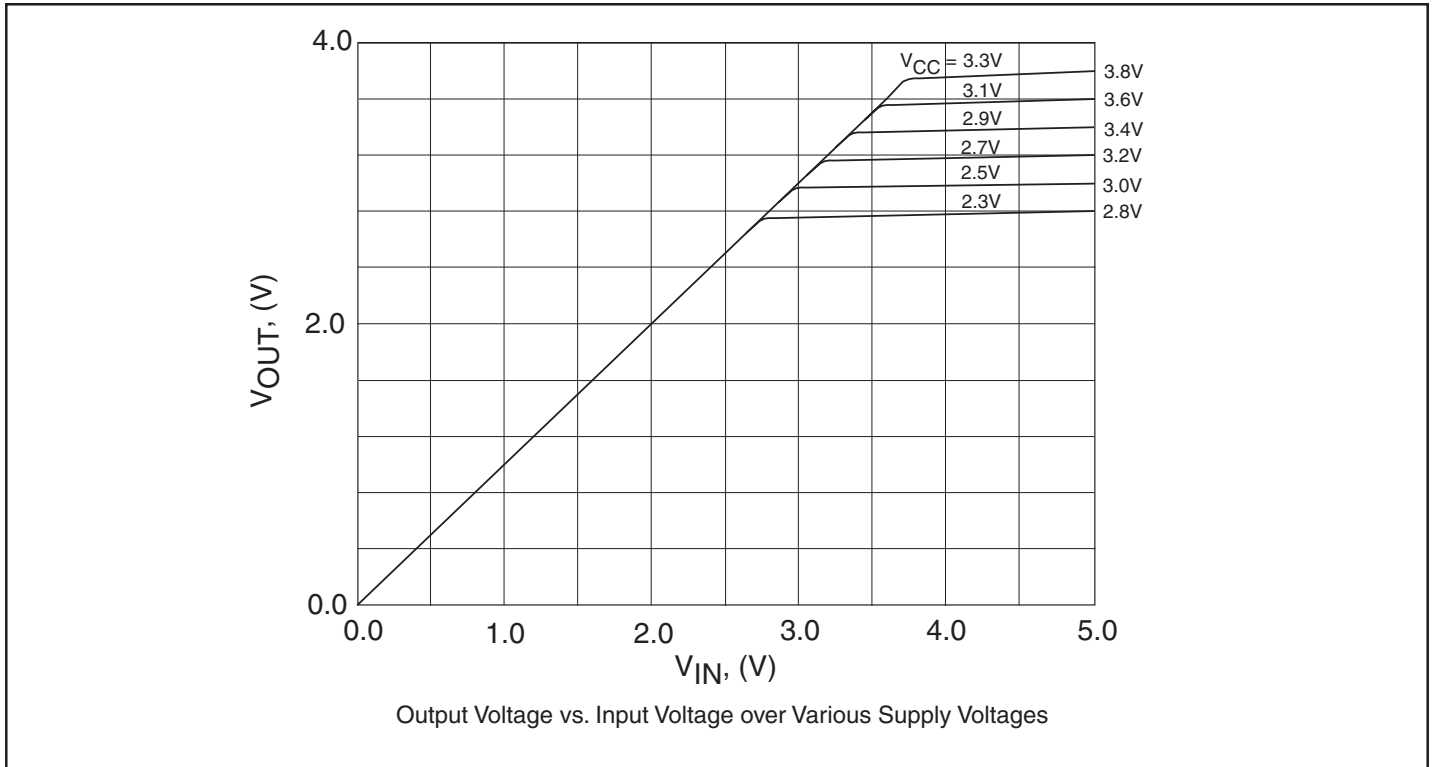

Output Voltage vs. Input Voltage over Various Supply Voltages

Packaging Mechanical: 20-pin 150-mil wide plastic QSOP (Q)

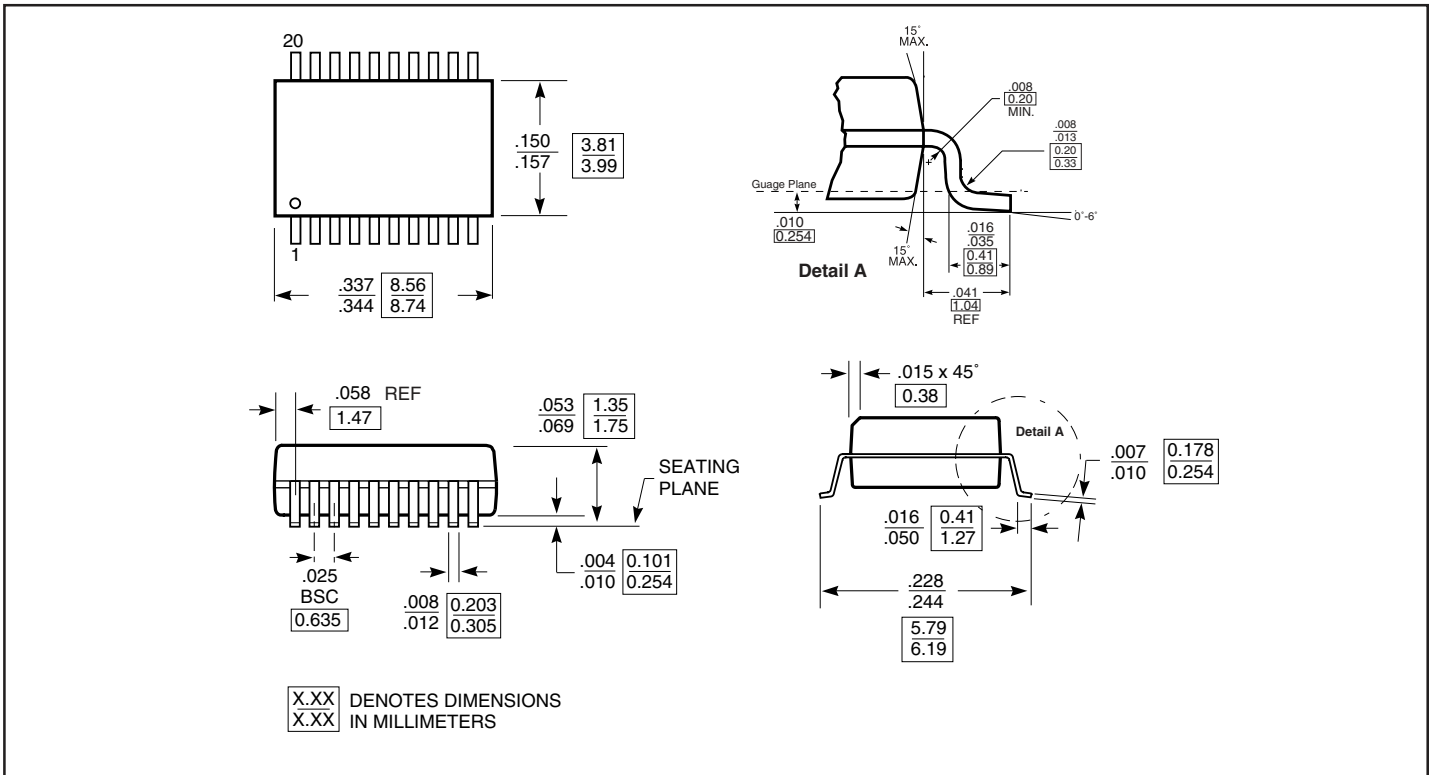

**Packaging Mechanical: 20-pin 173-mil wide plastic TSSOP (L)**

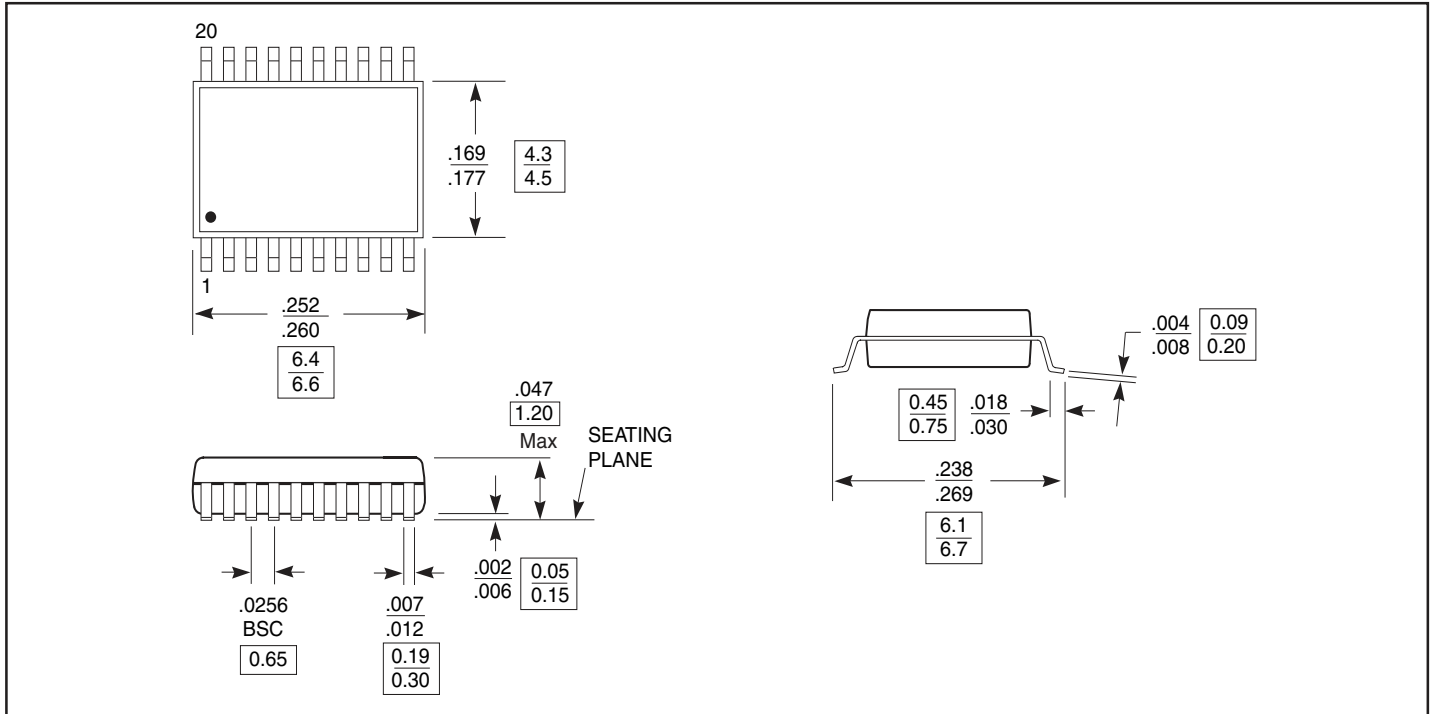

**Ordering Information**

Ordering Code	Package Code	Package Type
PI3C3245Q	Q	20-pin QSOP
PI3C3245QE	Q	Pb-free & Green, 20-pin QSOP
PI3C3245L	L	20-pin TSSOP
PI3C3245LE	L	Pb-free & Green, 20-pin TSSOP

**Notes:**

- Thermal characteristics can be found on the company web site at [www.pericom.com/packaging/](http://www.pericom.com/packaging/)
- E = Pb-free & Green
- Adding an X suffix = Tape/Reel