

- △ HOUSING: PCT, UL94V-0, COLOR BLACK.
- △ POSTS: PHOSPHOR BRONZE.
- △ POSTS: 0.00038[.000015] MIN GOLD ON MATING AREA, 0.00254[.000100] MIN TIN ON SOLDER END, ALL OVER 0.00127[.000050] MIN NICKEL ON ENTIRE POST.
- △ DATUMS S & T TO BE ESTABLISHED BY CUSTOMER.
- △ NO KEYING SLOT ON THIS END FOR 10 & 14 POSITION ASSEMBLIES.
- △ NO KEYING SLOT ON THIS END FOR 10 POSITION ASSEMBLIES.

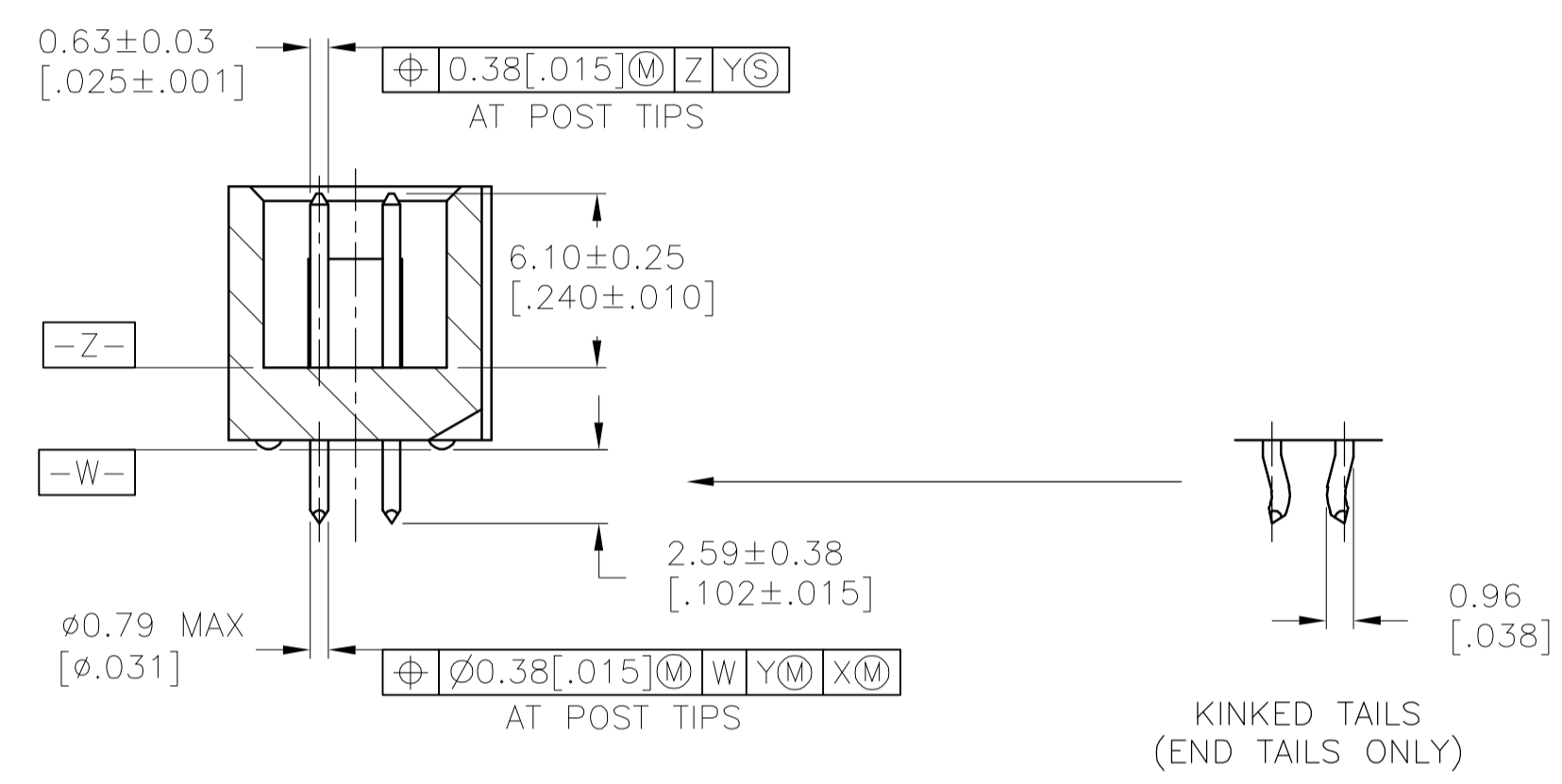

KINKED TAILS (END TAILS ONLY)

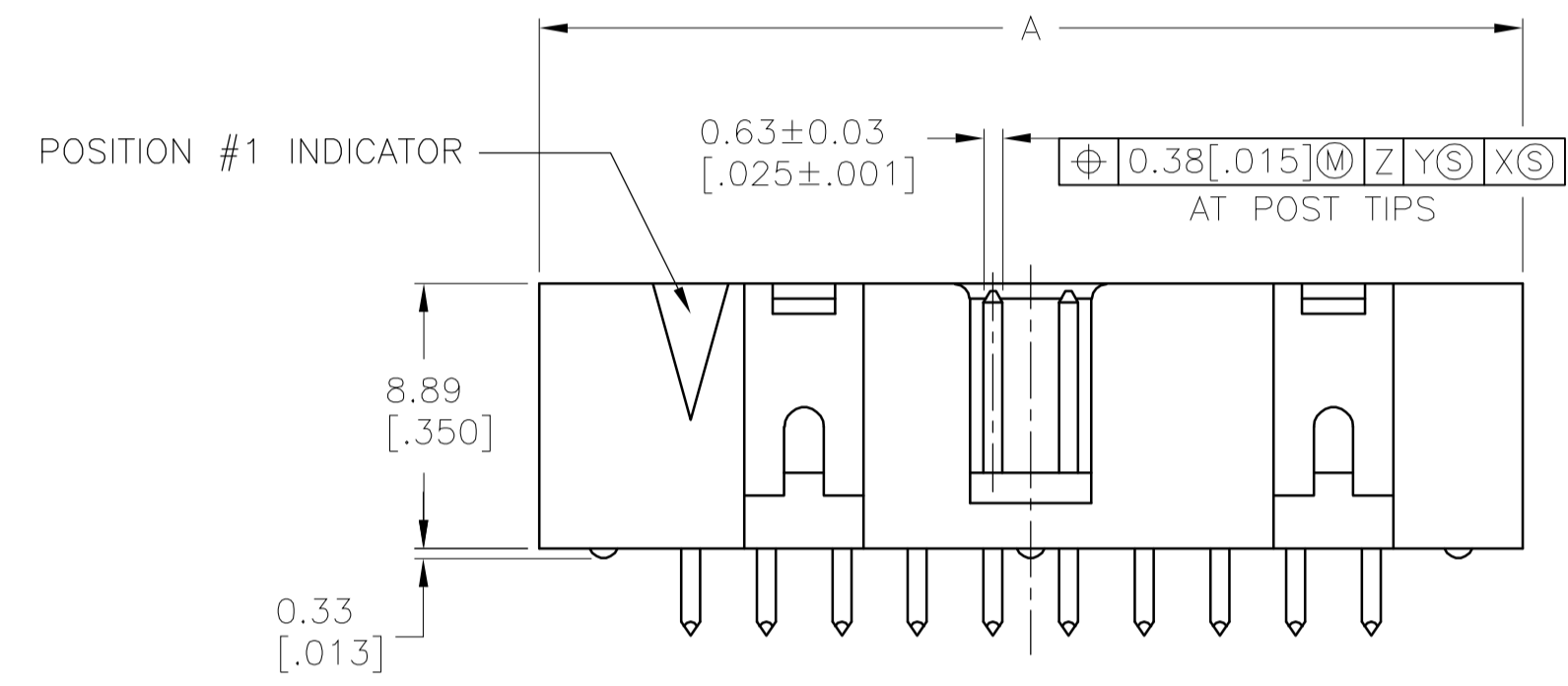
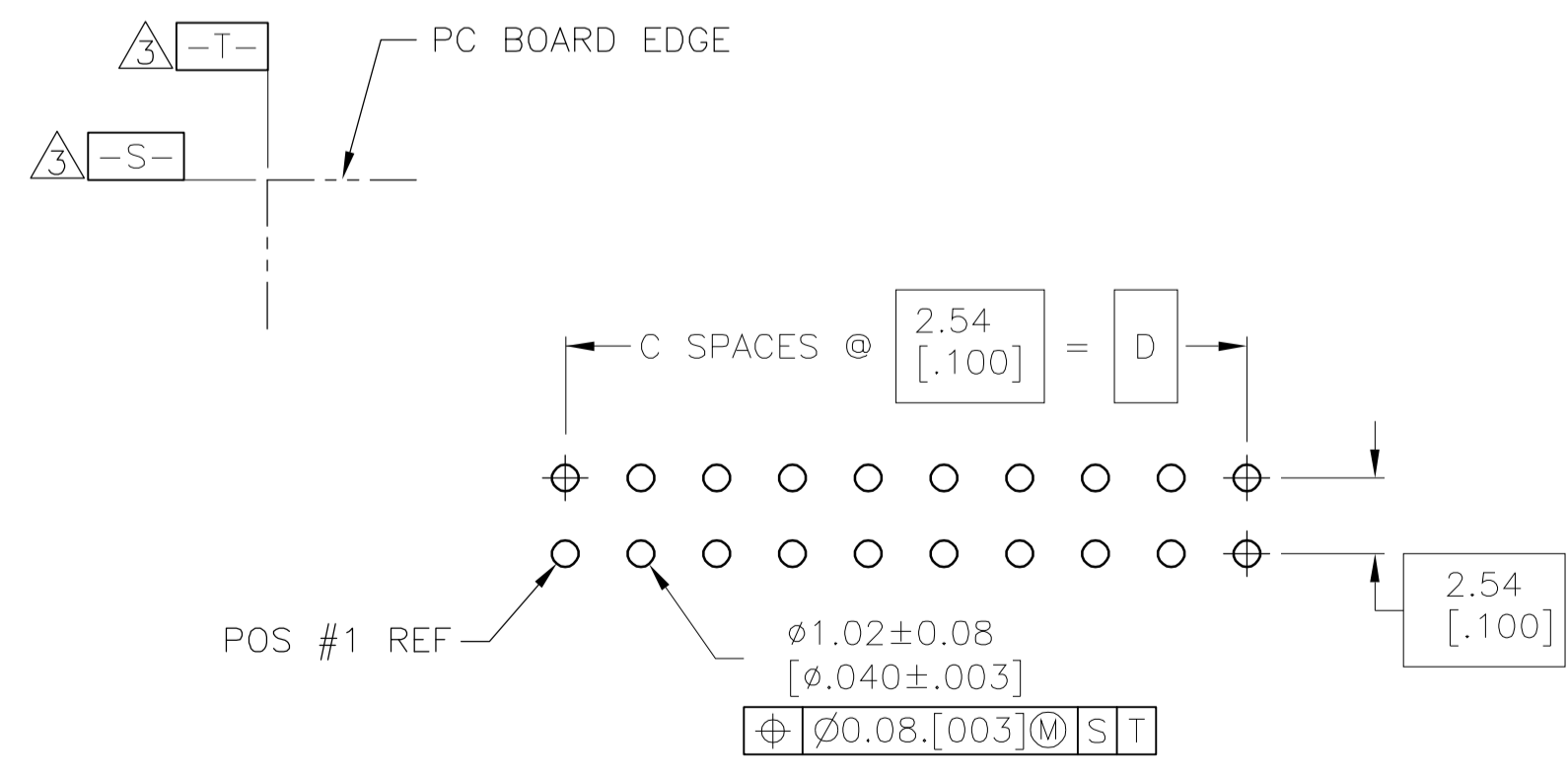
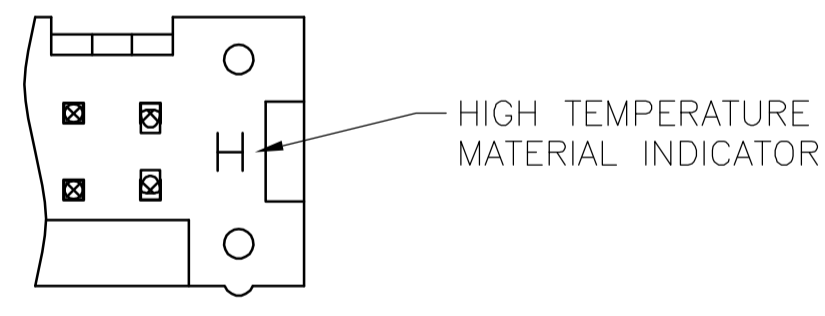

RECOMMENDED PC BOARD LAYOUT (VIEWED FROM CONNECTOR SIDE)

| | | | | | |
|---------------|----|---------------|---------------|-----------|-------------|
| 73.66 [2.900] | 29 | 81.28 [3.200] | 83.82 [3.300] | 60 | 1-1761610-6 |
| 60.96 [2.400] | 24 | 68.58 [2.700] | 71.12 [2.800] | 50 | 1-1761610-5 |
| 48.26 [1.900] | 19 | 55.88 [2.200] | 58.42 [2.300] | 40 | 1-1761610-3 |
| 40.64 [1.600] | 16 | 48.26 [1.900] | 50.80 [2.000] | 34 | 1-1761610-1 |
| 30.48 [1.200] | 12 | 38.10 [1.500] | 40.64 [1.600] | 26 | 1761610-9 |
| 27.94 [1.100] | 11 | 35.56 [1.400] | 38.10 [1.500] | 24 | 1761610-8 |
| 22.86 [0.900] | 9 | 30.48 [1.200] | 33.02 [1.300] | 20 | 1761610-7 |
| 17.78 [0.700] | 7 | 25.40 [1.000] | 27.94 [1.100] | 16 | 1761610-6 |
| 15.24 [0.600] | 6 | 22.86 [0.900] | 25.40 [1.000] | 14 | 1761610-5 |
| 10.16 [0.400] | 4 | 17.78 [0.700] | 20.32 [0.800] | 10 | 1761610-3 |
| D | C | B | A | NO OF POS | PART NUMBER |

**COPYRIGHT 2005
 TYCO ELECTRONICS CORP
 ALL RIGHTS RESERVED**

| | | | | |
|--|--------------------|--------------------------|------------------------------|---------------------|
| THIS DRAWING IS A CONTROLLED DOCUMENT. | | DWN J. GERACE 03FEB05 | Tyco Electronics Corporation | |
| DIMENSIONS: MM(INCHES) | | CHK S. BOLASH 03FEB05 | Harrisburg, Pa 17105 | |
| TOLERANCES UNLESS OTHERWISE SPECIFIED: | | APRD M. WALMSLEY 03FEB05 | NAME | |
| 0 PLC ± - | 1 PLC ± - | PRODUCT SPEC | | |
| 2 PLC ± - | 3 PLC ± 0.13[.005] | APPLICATION SPEC | | |
| 4 PLC ± - | ANGLES ± - | SIZE A1 | CAGE CODE 00779 | DRAWING NO. 1761610 |
| MATERIAL | FINISH | WEIGHT | RESTRICTED TO | |
| CUSTOMER DRAWING | | SCALE 4:1 | SHEET 1 OF 1 | REV B |