

## Setting Up the Evaluation Board for the ADP150

### FEATURES

**Input voltage range: 2.2 V to 5.5 V**

**Output current range: 0 mA to 150 mA**

**Output voltage accuracy:  $\pm 1\%$**

**Operating temperature range:  $-40^{\circ}\text{C}$  to  $+125^{\circ}\text{C}$**

### GENERAL DESCRIPTION

The [ADP150](#) evaluation board is used to demonstrate the functionality of the ADP150 linear regulator.

Simple device measurements such as line and load regulation, dropout voltage, and ground current can be demonstrated with only a single voltage supply, a voltage meter, a current meter, and load resistors.

For more information about the ADP150 linear regulator, see the ADP150 data sheet.

### EVALUATION BOARDS

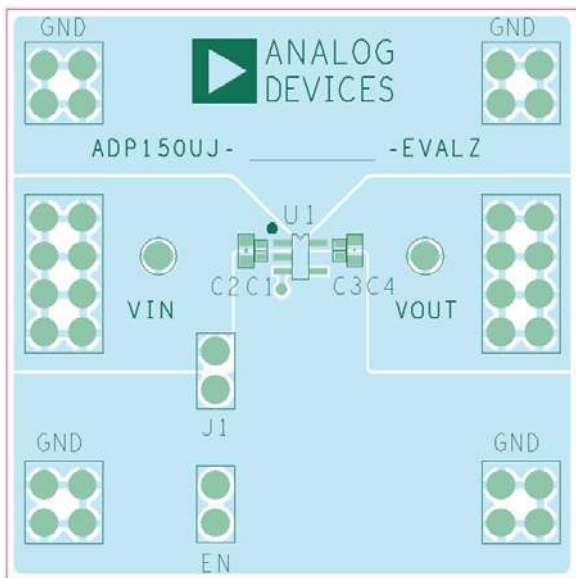

Figure 1. TSOT PCB Layout

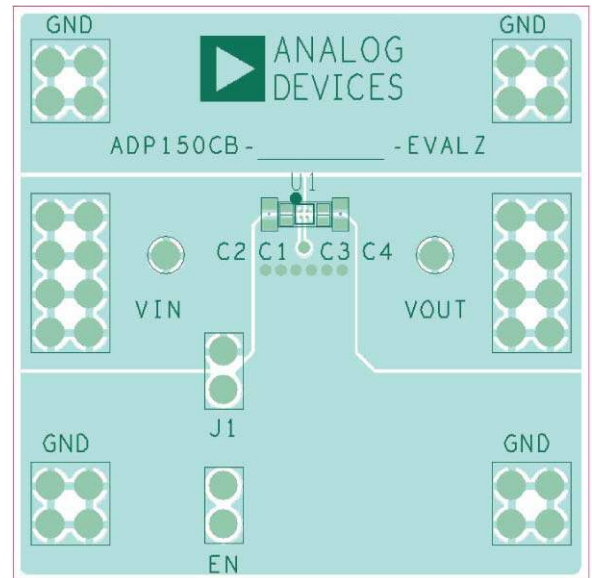

Figure 2. WLCSP PCB Layout

**TABLE OF CONTENTS**

Features .....	1	Load Regulation Measurements.....	5
General Description .....	1	Dropout Voltage Measurements.....	5
Evaluation Boards.....	1	Ground Current Measurements .....	6
Revision History .....	2	Ground Current Consumption .....	7
Evaluation Board Hardware.....	3	Ordering Information.....	8
Evaluation Board Configurations .....	3	Bill of Materials.....	8
Output Voltage Measurements .....	4	ESD Caution.....	8
Line Regulation Measurements .....	5		

**REVISION HISTORY**

1/10—Revision 0: Initial Version

## EVALUATION BOARD HARDWARE

### EVALUATION BOARD CONFIGURATIONS

The ADP150 evaluation board is supplied with different components, depending on the version that is ordered. Components common to both versions are C2, C4, and J1. Figure 3 and Figure 4 show the schematics of these evaluation board configurations. Table 1 describes the components.

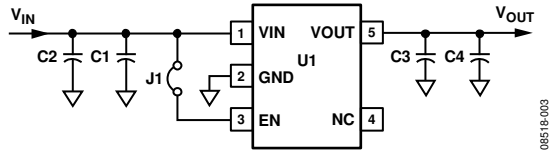

Figure 3. Evaluation Board Schematic, TSOT

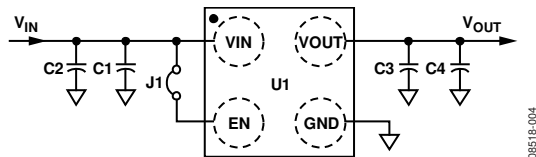

Figure 4. Evaluation Board Schematic, WLCSP

Table 1. Evaluation Board Hardware Components

Component	Description
U1 <sup>1</sup>	ADP150 low dropout linear regulator
C1 <sup>2</sup>	Input bypass capacitor, 1 $\mu$ F, 0402 size (not populated)
C2	Input bypass capacitor, 1 $\mu$ F, 0603 size
C3 <sup>2</sup>	Output capacitor, 1 $\mu$ F, 0402 size (not populated)
C4	Output capacitor, 1 $\mu$ F, 0603 size
J1	Jumper (connects EN to VIN for automatic startup)

<sup>1</sup> The evaluation board with the WLCSP package is the ADP150CB-3.3-EVALZ. The evaluation board with the TSOT package is the ADP150UJ-3.3-EVALZ.  
<sup>2</sup> C1 and C3 are not populated. The ADP150 evaluation board requires only one input bypass capacitor and one output capacitor for stable operation.

## OUTPUT VOLTAGE MEASUREMENTS

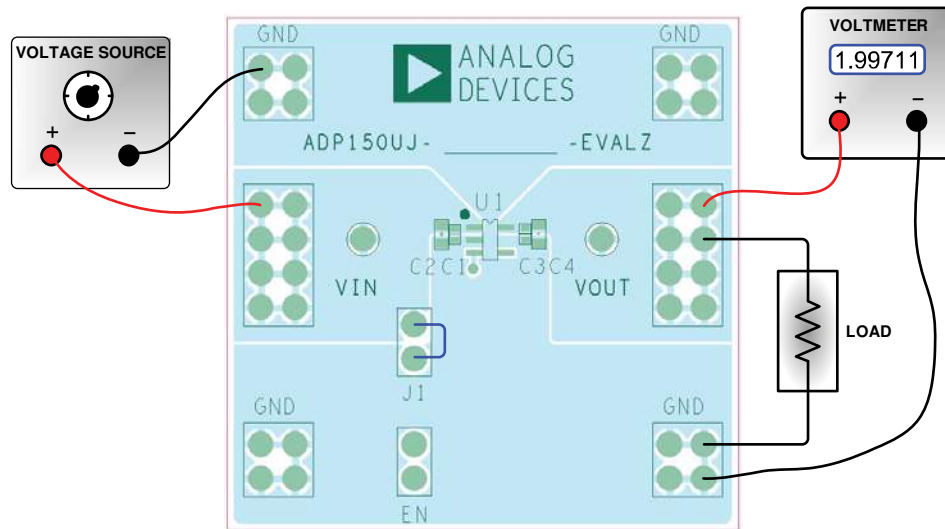

Figure 5. Output Voltage Measurement Setup, TSOT

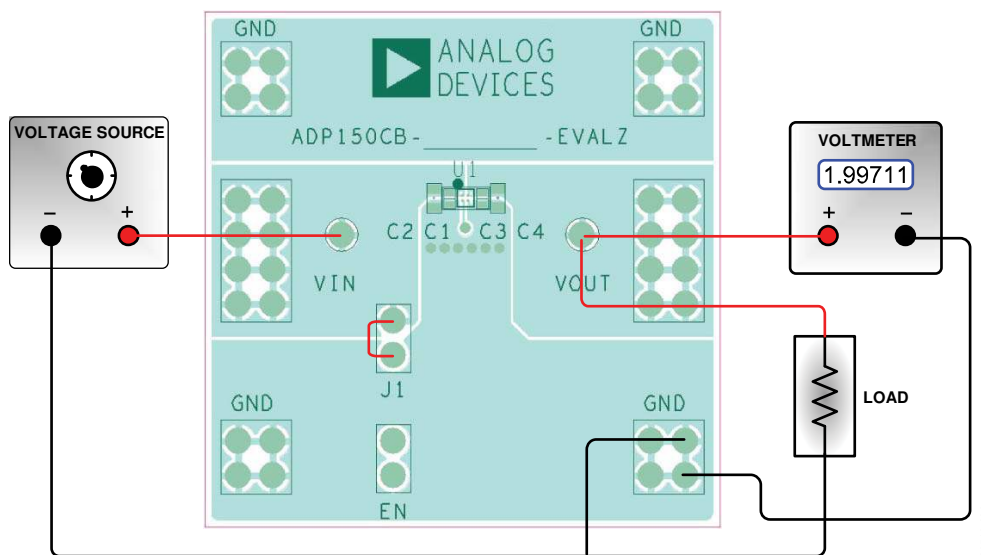

Figure 6. Output Voltage Measurement Setup, WLCSP

Figure 5 and Figure 6 show how the evaluation board can be connected to a voltage source and a voltage meter for basic output voltage accuracy measurements. A resistor can be used as the load for the regulator. Ensure that the resistor has a power rating that is adequate to handle the power that is expected to be dissipated across it. An electronic load can also be used as an alternative. Ensure that the voltage source can supply enough current for the expected load levels.

Follow these steps to connect to a voltage source and voltage meter:

1. Connect the negative terminal (–) of the voltage source to one of the GND pads on the evaluation board.
2. Connect the positive terminal (+) of the voltage source to the VIN pad of the evaluation board.
3. Connect a load between the VOUT pad and one of the GND pads.
4. Connect the negative terminal (–) of the voltage meter to one of the GND pads.
5. Connect the positive terminal (+) of the voltage meter to the VOUT pad.

When these steps are completed, the voltage source can be turned on. If J1 is inserted (connecting EN to VIN for automatic startup), the regulator powers up.

If the load current is large, the user must connect the voltage meter as close as possible to the output capacitor to reduce the effects of IR drops.

**LINE REGULATION MEASUREMENTS**

For line regulation measurements, the output of the regulator is monitored while its input is varied. For good line regulation, the output must change as little as possible with varying input levels. To ensure that the device is not in dropout mode during this measurement,  $V_{IN}$  must be varied between  $V_{OUTNOM} + 0.4\text{ V}$  (or 2.2 V, whichever is greater) and  $V_{INMAX}$ .

For example, for an ADP150 with a fixed 3.3 V output,  $V_{IN}$  must be varied between 3.7 V and 5.5 V. This measurement can be repeated under different load conditions. Figure 7 shows the typical line regulation performance of an ADP150 with a fixed 3.3 V output.

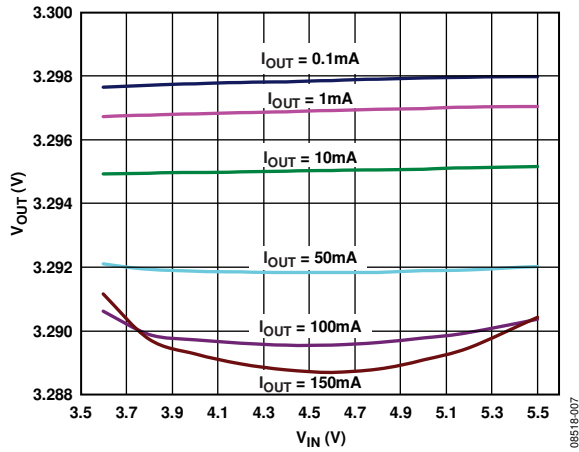

Figure 7. Output Voltage ( $V_{OUT}$ ) vs. Input Voltage ( $V_{IN}$ ) at  $T_A = 25^\circ\text{C}$

**LOAD REGULATION MEASUREMENTS**

For load regulation measurements, the output of the regulator is monitored while the load is varied. For good load regulation, the output must change as little as possible with varying load. The input voltage must be held constant during this measurement. The load current can be varied from 0 mA to 150 mA. Figure 8 shows the typical load regulation performance of an ADP150 with a fixed 3.3 V output for an input voltage of 3.7 V.

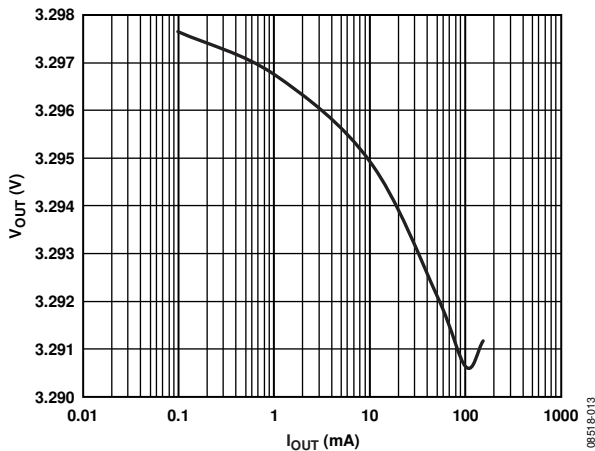

Figure 8. Output Voltage ( $V_{OUT}$ ) vs. Load Current ( $I_{OUT}$ ) at  $V_{IN} = 3.7\text{ V}$ ,  $V_{OUT} = 3.3\text{ V}$ ,  $T_A = 25^\circ\text{C}$

**DROPOUT VOLTAGE MEASUREMENTS**

Dropout voltage can be measured using the configurations shown in Figure 5 and Figure 6. Dropout voltage is defined as the input-to-output voltage differential when the input voltage is set to the nominal output voltage. This applies only to output voltages above 2.2 V. Dropout voltage increases with larger loads.

For more accurate measurements, a second voltage meter can be used to monitor the input voltage across the input capacitor. The input supply voltage may need to be adjusted to account for IR drops, especially if large load currents are used. Figure 9 shows the typical curve of dropout voltage measurements with different load currents.

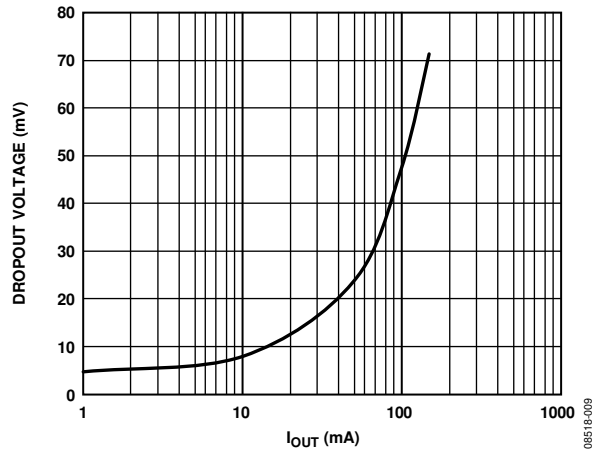

Figure 9. Dropout Voltage vs. Load Current ( $I_{OUT}$ ) at  $V_{OUT} = 3.3\text{ V}$ ,  $T_A = 25^\circ\text{C}$

## GROUND CURRENT MEASUREMENTS

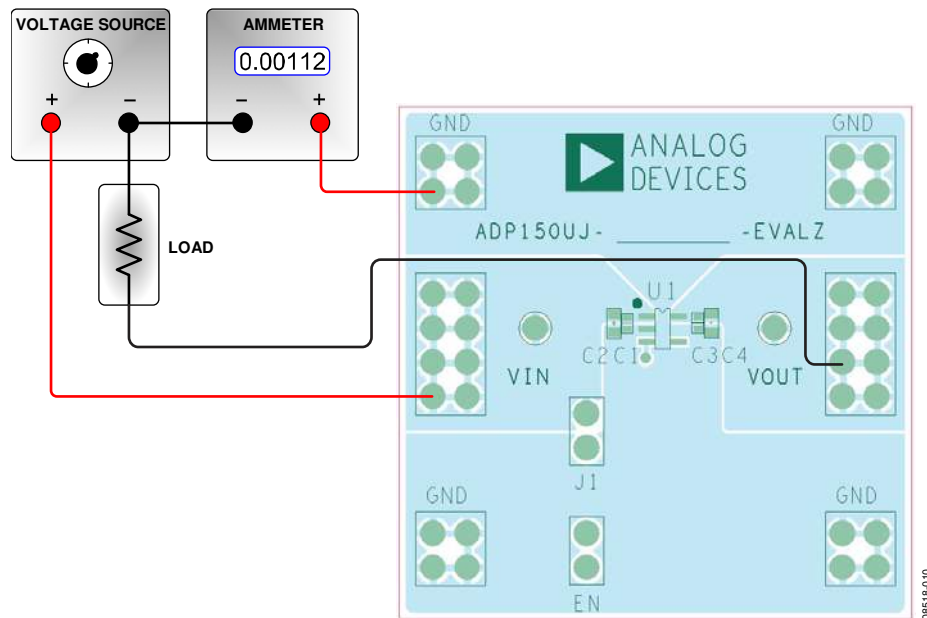

Figure 10. Ground Current Measurement Setup, TSOT

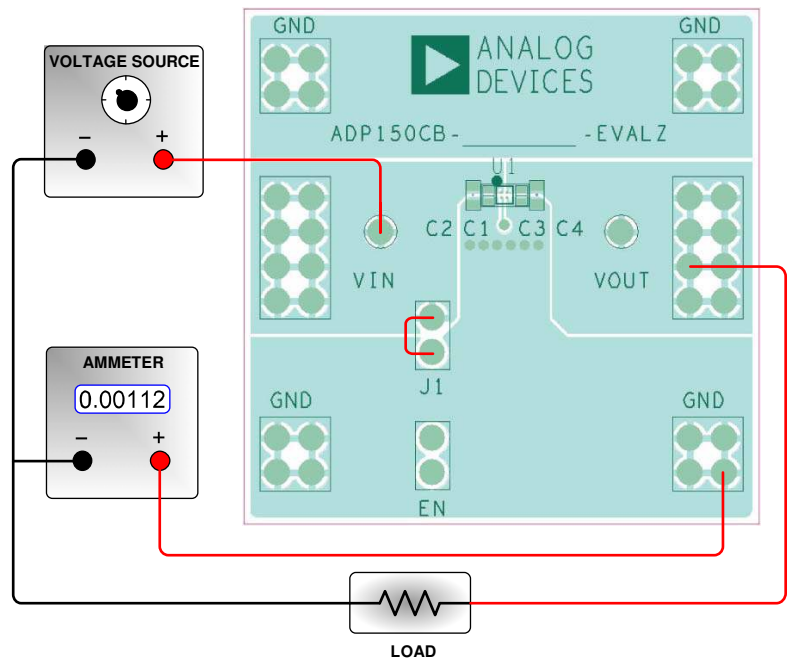

Figure 11. Ground Current Measurement Setup, WLCSP

Figure 10 and Figure 11 show how the evaluation board can be connected to a voltage source and an ammeter for ground current measurements. A resistor can be used as the load for the regulator. Ensure that the resistor has a power rating that is adequate to handle the power that is expected to be dissipated across it. An electronic load can be used as an alternative. Ensure that the voltage source can supply enough current for the expected load levels.

Follow these steps to connect to a voltage source and ammeter:

1. Connect the positive terminal (+) of the voltage source to the VIN pad of the evaluation board.
2. Connect the positive terminal (+) of the ammeter to one of the GND pads on the evaluation board.
3. Connect the negative terminal (-) of the ammeter to the negative (-) terminal of the voltage source.
4. Connect a load between the VOUT pad of the evaluation board and the negative (-) terminal of the voltage source.

When these steps are completed, the voltage source can be turned on. If J1 is inserted (connecting EN to VIN for automatic startup), the regulator powers up.

**GROUND CURRENT CONSUMPTION**

Ground current measurements can determine how much current the internal circuits of the regulator consume while the circuits perform the regulation function. To be efficient, the regulator must consume as little current as possible. Typically, the regulator uses the maximum current when supplying its largest load level (150 mA). Figure 12 shows the typical ground current consumption for various load levels at  $V_{OUT} = 3.3\text{ V}$  and  $T_A = 25^\circ\text{C}$ .

When the device is disabled ( $EN = GND$ ), ground current drops to less than  $1\ \mu\text{A}$ .

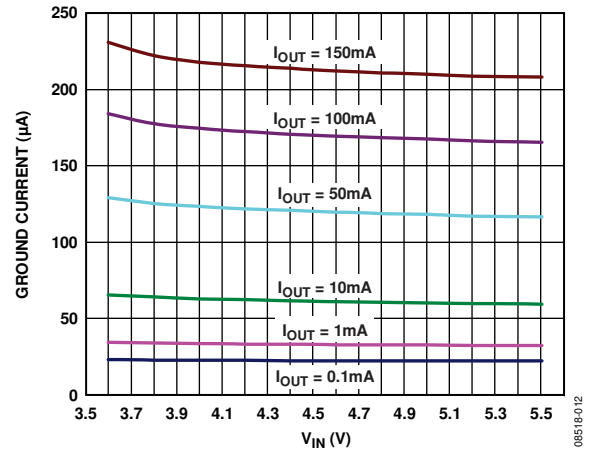

Figure 12. Ground Current vs. Input Voltage ( $V_{IN}$ ) at  $V_{OUT} = 3.3\text{ V}$ ,  $T_A = 25^\circ\text{C}$

## ORDERING INFORMATION

### BILL OF MATERIALS

Table 2.

Reference Designator	Description	Manufacturer	Part No.
C2, C4	Capacitor, MLCC, 1 $\mu$ F, 16 V, 0603, X5R	Murata (or equivalent)	GRM188R61C105KA93
J1	Jumper, single, STR, two pins	Sullins Connector Solutions	PEC02SAAN
U1	IC, LDO regulator	Analog Devices, Inc.	ADP150ACBZ-3.3-R7 (WLCSP) ADP150AUJZ-3.3-R7 (TSOT)

### ESD CAUTION



#### ESD (electrostatic discharge) sensitive device.

Charged devices and circuit boards can discharge without detection. Although this product features patented or proprietary protection circuitry, damage may occur on devices subjected to high energy ESD. Therefore, proper ESD precautions should be taken to avoid performance degradation or loss of functionality.

Evaluation boards are only intended for device evaluation and not for production purposes. Evaluation boards are supplied "as is" and without warranties of any kind, express, implied, or statutory including, but not limited to, any implied warranty of merchantability or fitness for a particular purpose. No license is granted by implication or otherwise under any patents or other intellectual property by application or use of evaluation boards. Information furnished by Analog Devices is believed to be accurate and reliable. However, no responsibility is assumed by Analog Devices for its use, nor for any infringements of patents or other rights of third parties that may result from its use. Analog Devices reserves the right to change devices or specifications at any time without notice. Trademarks and registered trademarks are the property of their respective owners. Evaluation boards are not authorized to be used in life support devices or systems.

©2010 Analog Devices, Inc. All rights reserved. Trademarks and registered trademarks are the property of their respective owners.  
UG08518-0-1/10(0)



www.analog.com