

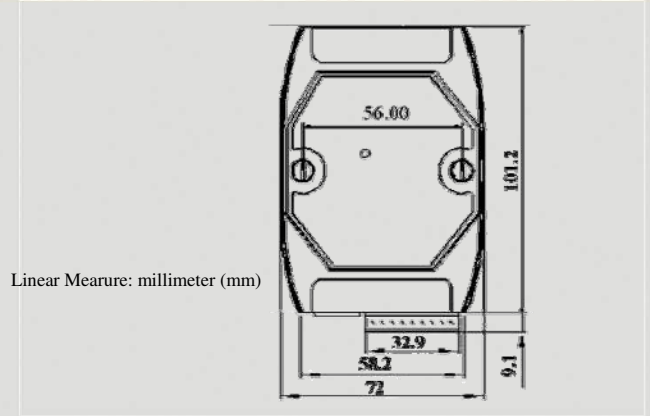

Intelligent Remote Maintenance Device Server



M2M-720-A



Linear Measure: millimeter (mm)

Dimensions

The M2M-720-A module is specially designed for the remote maintenance solution with voice streaming. This module provides 2 major technologies on networking: Voice streaming and Pair connection. The Pair connection means that the user can operate remote COM port device via Ethernet TCP/IP protocol just like a local COM port and the Voice streaming means the user can talk to remote operator while operate remote COM-linked devices. Furthermore, M2M-720-A integrates the Virtual com technology. That can resolve the insufficiency of real com port in PC. By applying this technology, the maintenance man can take the remote maintenance or monitor whatever time or place.

Features

- Support voice streaming on network
- Provide pair connection on network
- Server mode can manage max 64 clients
- Support Virtual COM technology
- Web-based administration
- Linux 2.6 platform
- Provide Static IP/DHCP/PPPoE
- Provide dynamic DNS function
- Provide event record and e-mail function
- Built-in web server, FTP server
- Built-in self-tuner ASIC chip for RS-485 port
- Robust, fan less design
- CE/FCC, EMI, RoHS compliance

9-pin screw terminal block

Pin	Name	Description
1	Trig	Trigger input
2	T.Gnd	GND of trigger input
3	RXD	Rx of RS-232
4	TXD	Tx of RS-232
5	GND	GND of RS-232
6	D+	Data+ of RS-485
7	D-	Data- of RS-485
8	PWR	V+ of Power Supply (+10 to +30 Vdc)
9	GND	GND of Power Supply

Web-based administration

- The M2M-720-A module built-in web server, the user can operate and set the module easily by web browser.

Pin Assignments

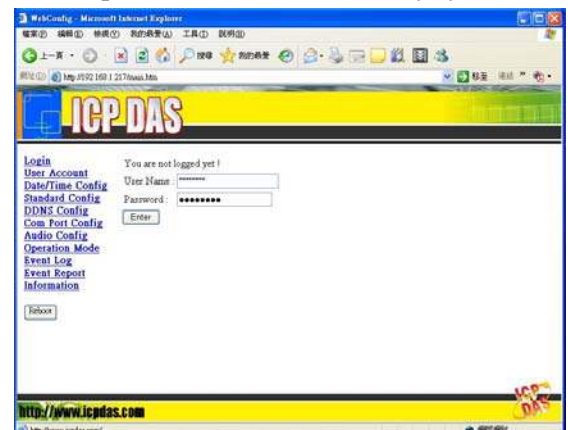

Hardware Specifications

Item	M2M-720-A
CPU	xScale PXA-255, 400 MHz processor
Flash	32 MB
SDRAM	64 MB
SRAM	256 KB
Ethernet	Ethernet Speed: 10/100M Ethernet interface: RJ-45 connector Internet connection type: DHCP, Static IP, PPPoE Ethernet protocol & services: TCP/IP, Web server, FTP server, Telnet & SSH
Audio	Microphone input and stereo speaker output
COM port	COM1: RS-232 interface -- 3-pin screw terminal block RS-232: TX, RX, GND COM2: RS-485 interface -- 2-pin screw terminal block RS-485: D+, D-, self-tuner ASIC inside Baud Rate : 1200/2400/4800/9600/19200/38400/57600/115200 bps Data Format: 5/6/7/8 data bits, None/Odd/Even parity bit, 1/2 stop bit
Power Requirement	+10 ~ +30 V _{DC}
Power Consumption	4.6 W
Operating Temp.	-20°C ~ +60 °C
Storage Temp.	-25°C ~ +85 °C
Dimensions (W x L x H)	72 x 33 x 110 (mm)

Application

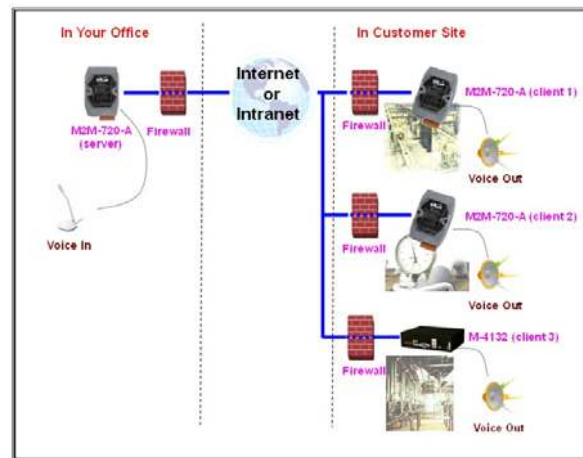
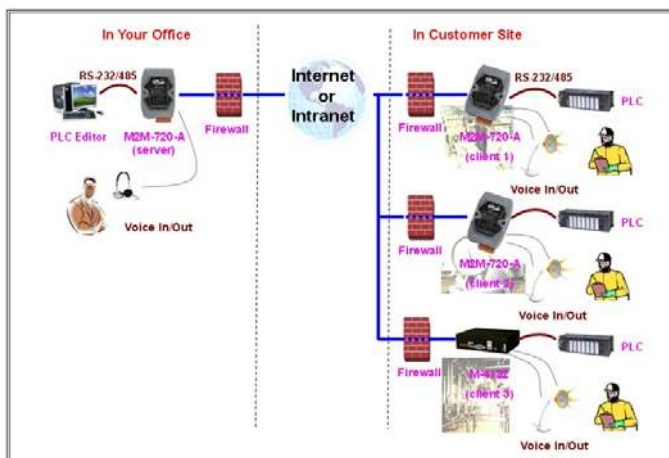

Ordering Information

M2M-720-A	Intelligent Remote Maintenance Device Server
------------------	--