

PART NO.	ENG. NO.	INTERLEAF PAPER OPTION
02-09-1104	1189-A(P901)L	
02-09-1102	1189-A(P901)	
02-09-5111	1189-A(P591)L	
02-09-5102	1189-A(P591)	
02-09-5106	1189-A(P550)L	
02-09-5100	1189-A(P550)	
02-09-6102	1189-A(P901)-I	YES

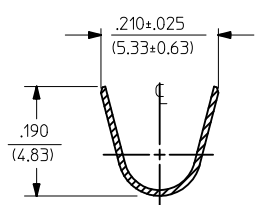

SECT. "A-A"

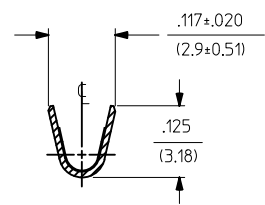

SECT. "B-B"

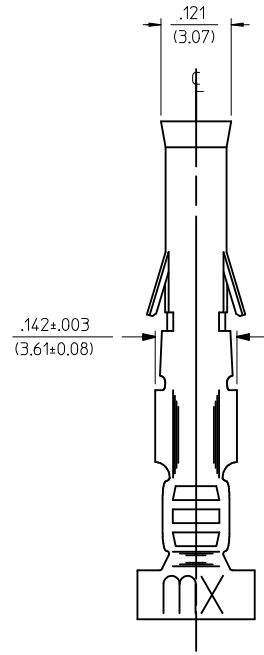
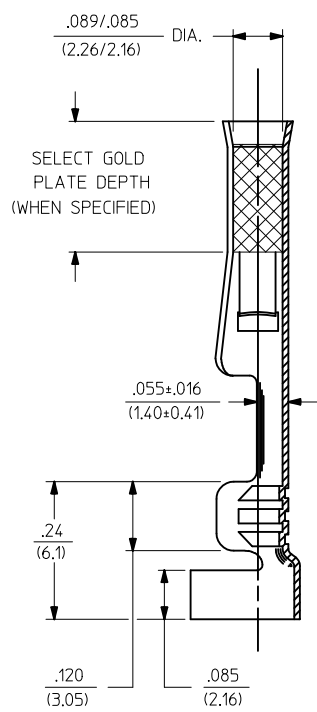
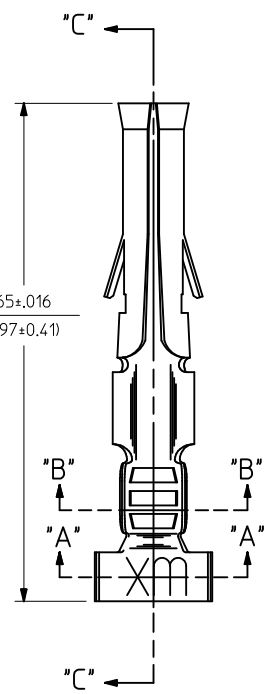
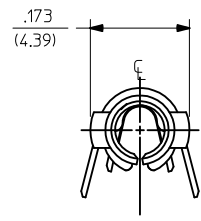
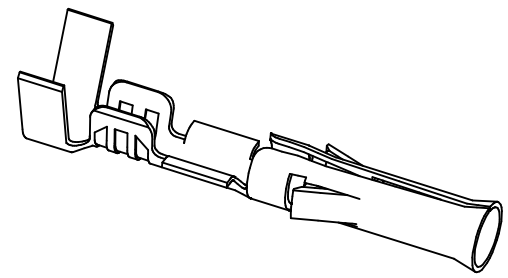

SECT. "C-C"



LEGEND

1189-A(****)*-*
 INTERLEAF PAPER OPTION
 FORM: BLANK=CHAIN, L=LOOSE
 FINISH CODE: P=PREPLATE, BLANK=POSTPLATE
 BLANK: INTERLEAF PAPER ON FIRST FEW WRAPS ONLY.
 I: INTERLEAF PAPER THROUGH OUT REEL.

- NOTES:
- MATERIAL: CARTRIDGE BRASS, ALLOY #C26000, .010/(0.25) THICK
 - FINISH CODES:
 - 901 HOT TIN DIP .000020/(0.00051) MIN.
 - 591 SELECT GOLD PLATE .000050/(0.00127) MIN. IN CONTACT AREA, OVER .000050/(0.00127) MIN. NICKEL OVERALL WITH .000010/(0.00025) MAX. GOLD FLASH OVERALL.
 - 550 SELECT GOLD PLATE .000015/(0.00038) MIN. IN CONTACT AREA, OVER .000030/(0.00076) MIN. NICKEL OVERALL WITH .000010/(0.00025) MAX. GOLD FLASH OVERALL.
 - *THE PRIMARY SHIPPING CARTON WILL BE LABELED, "COMPLIANT TO RoHS DIRECTIVE 2002/95/EC AND ELV ANNEX OF DIRECTIVE 2000/53/EC", AND CARTONS WITHOUT THIS LABEL MAY CONTAIN PRODUCT WITH TIN-LEAD.

- THIS PART CONFORMS TO PROD. SPEC. 02-09.
- PACKAGING INFORMATION: NOT AVAILABLE
- TERMINAL FOR USE WITH .093/(2.36) SERIES HOUSINGS AND WILL ACCEPT 14 THRU 20 AWG WIRE.
- INSERTION FORCE: 3.5 LBS. MAX. WHEN TERMINAL IS INSERTED INTO AN .093 SERIES HOUSING.
- RETENTION: 20 LBS. MIN. FROM HOUSING.

ADD P/N 02-09-6102 EC NO: UCP2012-2714 DRW:NAELHAG CHKD:JBELL APPR:FSMITH	2012/02/20 2012/02/22 2012/04/25	DESCRIPTION REV	QUALITY SYMBOLS ▽=0 ▽=0	GENERAL TOLERANCES (UNLESS SPECIFIED)	DIMENSION STYLE IN/MM	SCALE 6:1	DESIGN UNITS INCH	THIRD ANGLE PROJECTION																								
			<table border="1"> <thead> <tr> <th></th> <th>mm</th> <th>INCH</th> </tr> </thead> <tbody> <tr> <td>4 PLACES ± ---</td> <td>± ---</td> <td>± ---</td> </tr> <tr> <td>3 PLACES ± ---</td> <td>± .010</td> <td>± .010</td> </tr> <tr> <td>2 PLACES ± 0.25</td> <td>± .014</td> <td>± .014</td> </tr> <tr> <td>1 PLACE ± 0.35</td> <td>± ---</td> <td>± ---</td> </tr> </tbody> </table>		mm	INCH	4 PLACES ± ---	± ---	± ---	3 PLACES ± ---	± .010	± .010	2 PLACES ± 0.25	± .014	± .014	1 PLACE ± 0.35	± ---	± ---	<table border="1"> <thead> <tr> <th>DRAWN BY</th> <th>DATE</th> </tr> </thead> <tbody> <tr> <td>GEP</td> <td>1987/10/26</td> </tr> <tr> <th>CHECKED BY</th> <th>DATE</th> </tr> <tr> <td>RW</td> <td>1987/10/26</td> </tr> <tr> <th>APPROVED BY</th> <th>DATE</th> </tr> <tr> <td>RAS</td> <td>1987/10/26</td> </tr> </tbody> </table>	DRAWN BY	DATE	GEP	1987/10/26	CHECKED BY	DATE	RW	1987/10/26	APPROVED BY	DATE	RAS	1987/10/26	TITLE CRIMP TERMINAL, FEMALE, .093/(2.36) DIA. 14-20 AWG
	mm	INCH																														
4 PLACES ± ---	± ---	± ---																														
3 PLACES ± ---	± .010	± .010																														
2 PLACES ± 0.25	± .014	± .014																														
1 PLACE ± 0.35	± ---	± ---																														
DRAWN BY	DATE																															
GEP	1987/10/26																															
CHECKED BY	DATE																															
RW	1987/10/26																															
APPROVED BY	DATE																															
RAS	1987/10/26																															

DRAFT WHERE APPLICABLE MUST REMAIN WITHIN DIMENSIONS

THIS DRAWING CONTAINS INFORMATION THAT IS PROPRIETARY TO MOLEX INCORPORATED AND SHOULD NOT BE USED WITHOUT WRITTEN PERMISSION