

PRODUCT NO.
10148666-001LF

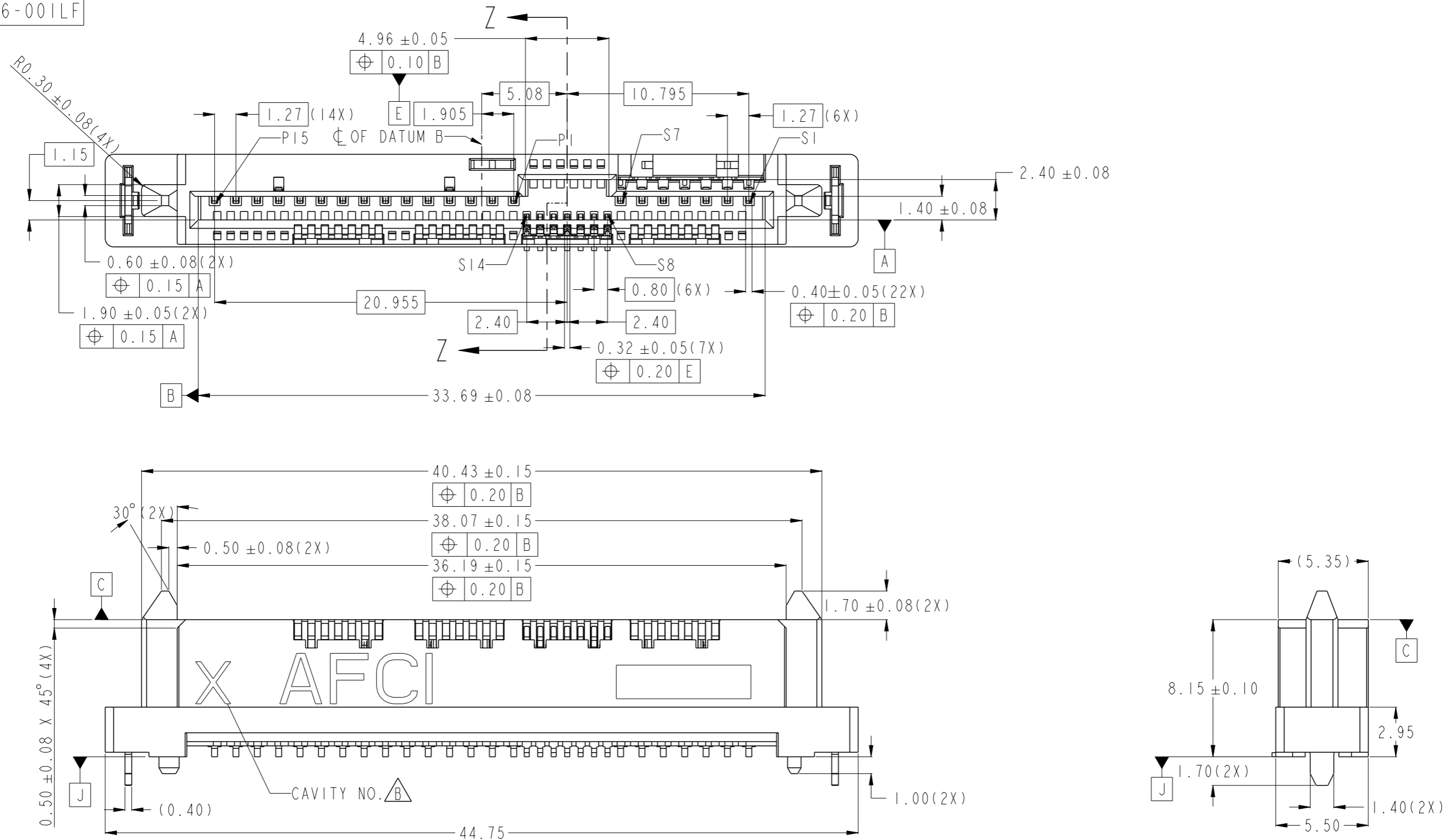

SCALE 4:1

spec ref	-	dr	Jeffrey Lim	2019/08/07	projection	MM	size	A3	scale	1:1
tolerance std	TOLERANCES UNLESS OTHERWISE SPECIFIED	eng	Jeffrey Lim	2021/02/02			ecn no	ELX-S-39875-1		
-		chr	-	-			rel level	Released		
surface	linear	0.X	±		product family		-			
		0.XX	±0.20		Amphenol FCI		dwg no	10148666	rev	B
		0.XXX	±		amphenol-icc.com		cat. no.	-	Product - Customer Drw	
	angular	0°	±3°		24G SAS RECEPTACLE VERTICAL SMT TYPE ASSY		sheet 1 of 3			

PRODUCT NO.
SEE TABLE

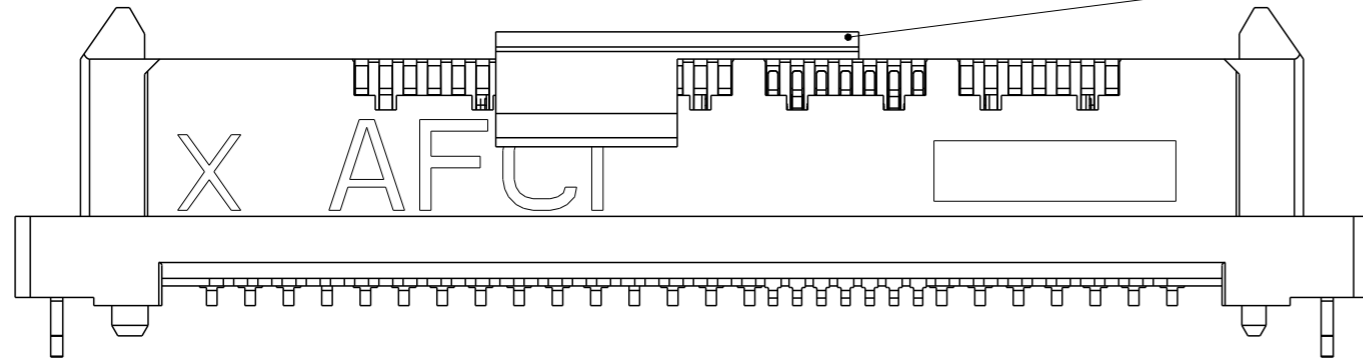
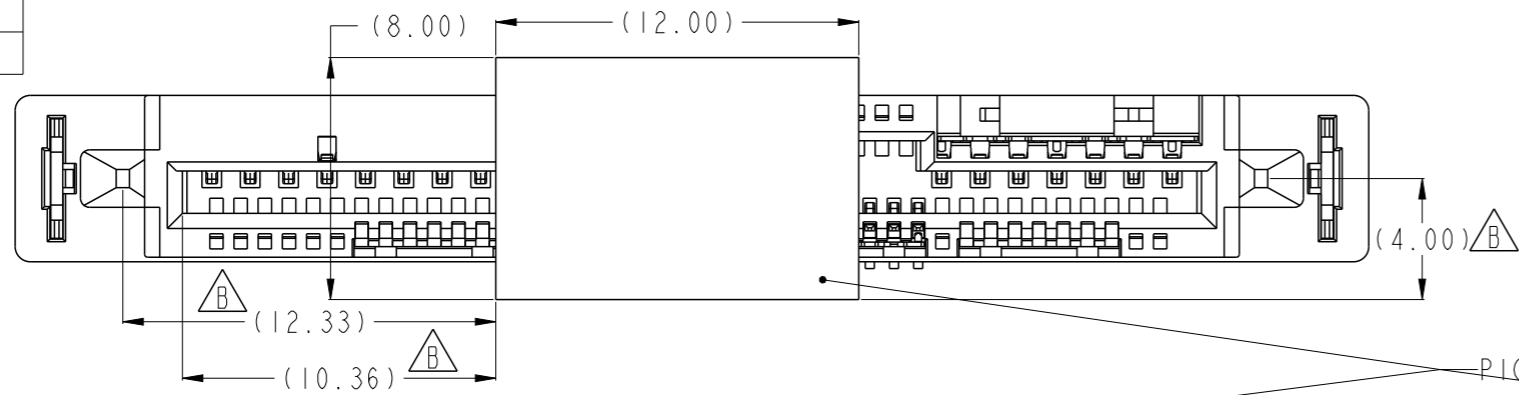

PICK AND PLACE CAP

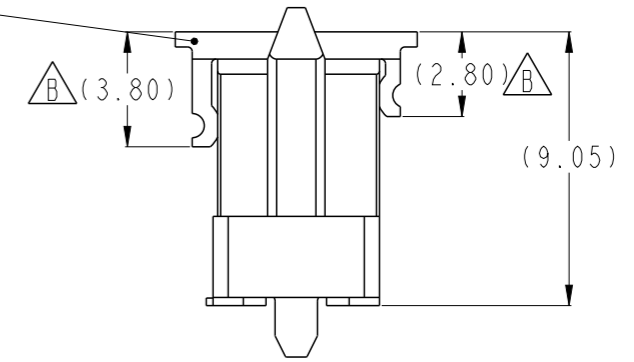

SCALE 4:1

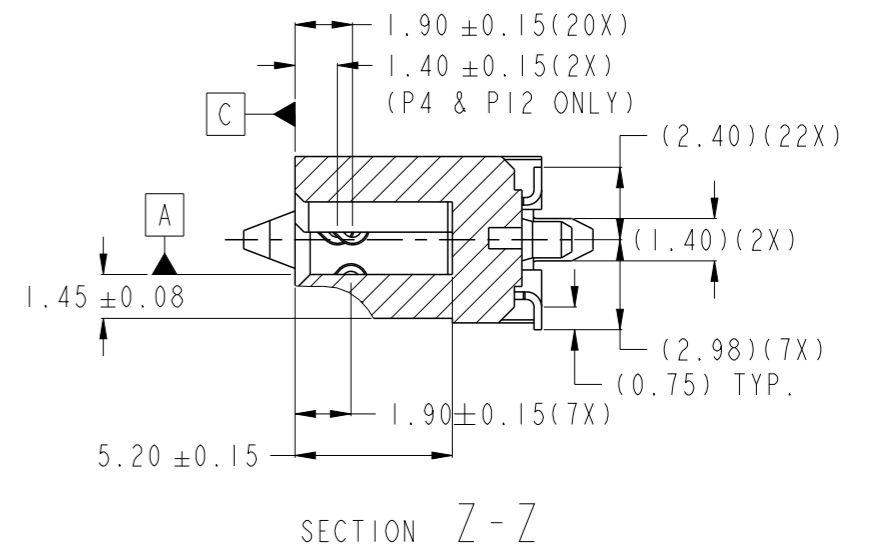
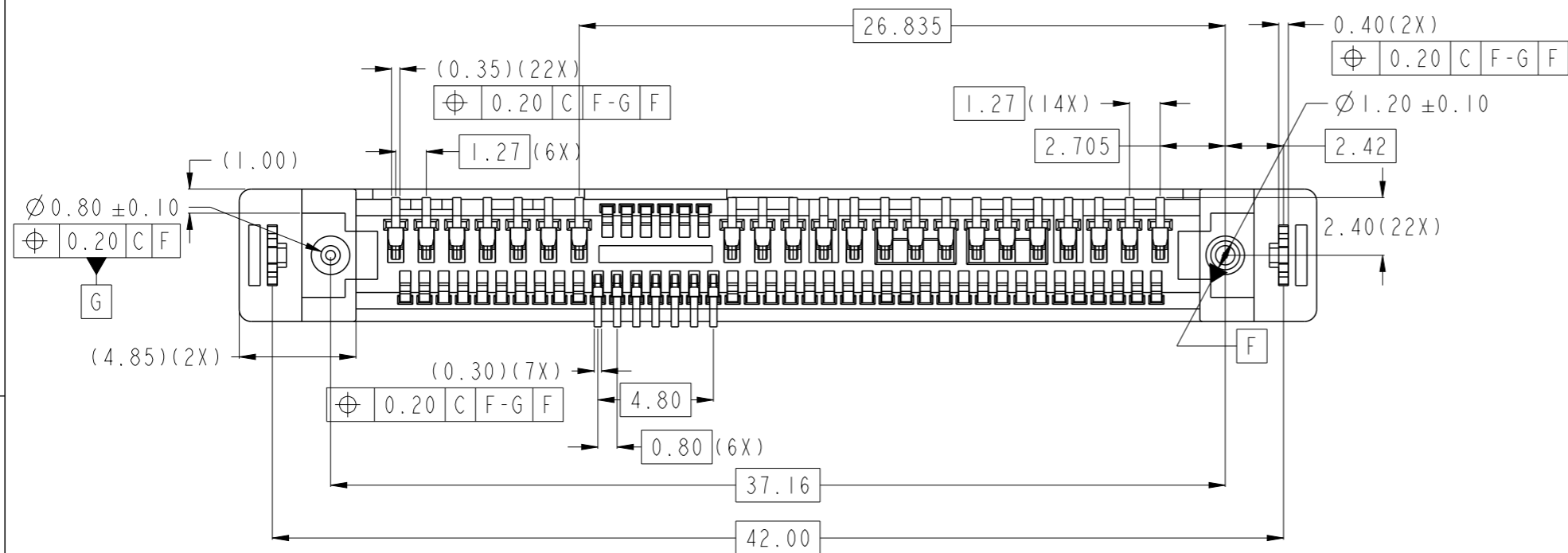

spec ref	-	dr	Jeffrey Lim	2019/08/07	projection	MM	size	A3	scale	4:1	
tolerance std	TOLERANCES UNLESS OTHERWISE SPECIFIED	eng	Jeffrey Lim	2021/02/02			ecn no	ELX-S-39875-1			
-		chr	-	-			rel level	Released			
surface	linear	appr	Koon-Poh Tay	2021/02/16	product family	-	rel level	Released			
-	angular	0°	±3°	Amphenol FCI	24G SAS RECEPTACLE VERTICAL SMT TYPE ASSY		dwg no	10148666		rev	B
-	-	0°	±3°	amphenol-icc.com	cat. no.	-	Product - Customer Drw	sheet 2 of 3			

