

**ZL2105EV2**  
**Evaluation Board (Rev 1)**

AN1467  
 REV.0.00  
 May 07, 2009

**Description**

The ZL2105 is an innovative mixed-signal power management and conversion IC that combines an integrated step-down DC-DC converter with key power and thermal management functions in a single package. The ZL2105EV2 platform allows evaluation of the features in the highly configurable ZL2105 in either stand-alone mode or via an I<sup>2</sup>C/SMBus interface.

A USB-to-SMBus adapter board can be used to connect the ZL2105EV2 board to a PC. The PMBus command set is accessed by using the Zilker Labs PowerNavigator™ evaluation software from a PC running Microsoft Windows.

**Features**

- Small, compact design
- PMBus control
- Pin-strap selection for stand-alone operation
- V<sub>OUT</sub> settable from +0.6 V to +5 V
- Convenient power connection
- Onboard enable switch
- Power good indicator

**Target Specifications**

This board has been designed as a buck regulator for the following conditions:

- V<sub>IN</sub> = 12 V (Board range 4.5 V to 14 V)
- V<sub>OUT</sub> = 3.3 V (Board range 0 to 5 V)
- I<sub>MAX</sub> = 3 A (Board range 0 to 3 A)
- f<sub>sw</sub> = 400 kHz
- Efficiency: 83% peak
- Output ripple: 0.5%
- Dynamic response: 3% (1–2A step, di/dt=2.5A/μs)
- Temperature: 25°C

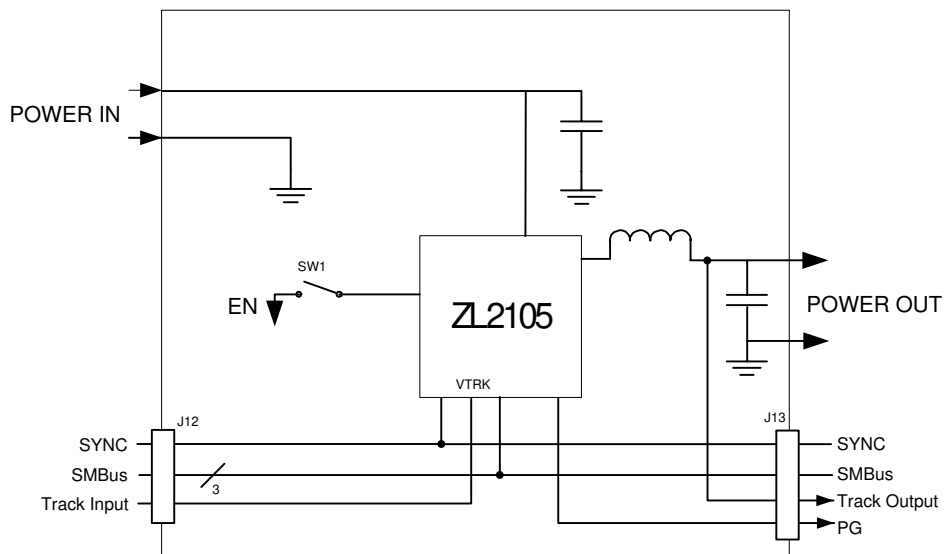

Figure 1. ZL2105EV2 Block Diagram

---

## Functional Description

---

The ZL2105EV2 provides all circuitry required to demonstrate the features of the ZL2105. The ZL2105EV2 has a functionally-optimized ZL2105 circuit layout that allows efficient operation up to the maximum output current. Power and load connections are provided through plug-in sockets.

Stand alone operation is achieved using the pin-strap settings for the device. The pin-strap settings are described in the ZL2105 data sheet [1].

The ZL2105 Evaluation Board is shown in Figure 2. The SMBus address is selectable through jumpers on the top side of the board. All power to the board (VIN and I<sup>2</sup>C bus) must be removed before changing the jumpers. The back side of the board has 0402 resistor footprints for setting the application pins using resistors.

The hardware enable function is controlled by a toggle switch on the ZL2105EV2 board. The power good (PG) LED is powered from the SMBus/I<sup>2</sup>C source; it indicates the correct state of PG when external power is applied to the ZL2105EV2 board. The right angle headers at opposite ends of the board are for connecting a USB to I<sup>2</sup>C control board or for daisy chaining of multiple evaluation boards.

Figure 3 shows the ZL2105 operational circuit. The circuit consists of the ZL2105 power conversion and management IC with its minimal component count to realize a buck converter. The board layout has been optimized for thermal performance. For thermal design considerations relating to the ZL2105, refer to Zilker Labs application note AN10[2].

Figure 5 on Page 8 illustrates the input and output power connections for the ZL2105. The optional input capacitors and output capacitors are also shown on this page.

---

## Operation

---

### Stand Alone Operation

The ZL2105 is easy to setup and operate. It is configured, out of the box, to provide 3.3 V at 3 A from a 12 V source. All input and output connections should be made before turning the input supply on.

When the input power supply is turned on, the ZL2105 will output the configured voltage and the load applied to VOUT+/VOUT- can be varied.

To modify the pin-strap setting of the ZL2105, input power must be turned off. The user pin-strap resistor pads are on the bottom side of the ZL2105EV2 PCB. Once the desired pin-strap settings and component changes have been applied, power can be turned on and the output can be evaluated for the newly configured mode. Refer to the ZL2105 data sheet [1] for pin-strap and resistor setting information. Refer to Figure 2 for resistor pad locations.

### PMBus Operation

The ZL2105 utilizes the PMBus protocol. The PMBus functionality can be controlled via USB from a PC running the Zilker Labs evaluation software in a Windows XP or Windows 2000/NT operating system.

Install the PowerNavigator software using the CD included in the ZL2105EV2 kit or download it from the web at [www.zilkerlabs.com](http://www.zilkerlabs.com).

For PMBus operation, connect another Zilker Labs evaluation board such as the ZL2005EV1 or the USB-to-SMBus adapter board to J12 of the ZL2105EV2 board. When using multiple evaluation boards together, verify that each device is assigned a different SMBus address. Connect the desired load and an appropriate power supply to the input. Place the ENABLE switch in "DISABLE" and turn on the power.

The evaluation software allows modification of all ZL2105 PMBus parameters. Manually configure the ZL2105 through the various

screens or load a predefined scenario from a configuration file.

Use the mouse-over pop-ups for help with PowerNavigator. Refer to Zilker Labs application note AN13 [3] for PMBus details.

The ENABLE switch can then be moved to “ENABLE” and the ZL2105 can be tested. Alternately, the PMBus ON-OFF CONFIG and OPERATION commands may be used.

## Loop Compensation Settings

By default, the ZL2105 EVB is configured for 12 V to 3.3 V conversion at 3 A. The output voltage can be changed by using the V1 and V0 resistor pads or through the use of PMBus commands. If the output voltage is set to 1V or below, the loop compensation needs to be modified. Table 1 summarizes the PID settings. This is achieved by using PMBus commands or by modifying the PowerPlan configuration file.

**Table 1. PID Settings versus Output Voltage**

V <sub>OUT</sub> Range	PID Setting
1V < V <sub>OUT</sub> ≤ 5.0V	A=5000, B=-9016, C=4170
V <sub>OUT</sub> ≤ 1V	A=10000, B=-18101, C=8324

These settings are included in the configuration file that is stored on the ZL2105 EVB and is shown here and at the end of this data sheet for reference.

For output voltages greater than 1V, the loop compensation is set as:

```
#Loop compensation for 12v:3.3v,
PID_TAPS      A=5000, B=-9016, C=4170
#NLR_CONFIG Enable,1.5%,No Outer,1.5%,3,3,0
NLR_CONFIG    0xA250
```

When the output voltage is set to 1V or less, the loop compensation should be:

```
#Loop compensation for 12V:0.8V
PID_TAPS      A=10000, B=-18101, C=8324
#NLR_CONFIG Enable,1.5%,No Outer,2%,3,3,0
NLR_CONFIG    0xA350
```

## Quick Start Guide

---

### Stand Alone Operation

1. Set ENABLE switch to “DISABLE”
2. Apply load to VOUT+/VOUT-
3. Connect power supply to VIN+/VIN- (supply turned off)
4. Turn power supply on
5. Set ENABLE switch to “ENABLE”
6. Test ZL2105 operation
7. To change hardware settings, turn input power supply OFF, modify resistor settings and then turn the input power supply ON

### USB (PMBus) Operation

1. Follow step 1 - 4 above
2. Insert the Zilker Labs Eval Kit CD
3. Connect USB-to-SMBus adapter board to J12 of ZL2105EV2
4. Connect supplied USB cable from computer to USB-to-SMBus adapter board
  - a. Upon first-time connection, the Found New Hardware Wizard will appear.
  - b. Windows XP users: Select ‘No’ at prompt to search the Internet for drivers.
  - c. Follow the steps on the screen to install the drivers from the CD.
5. Install the PowerNavigator evaluation software by running setup.exe from the PowerNavigator\_installer folder on the CD.
6. Set voltage to desired value in GUI.
7. Set ENABLE switch on EVB to “ENABLE”
8. Monitor and configure EVB using PMBus commands in the evaluation software
9. Test the ZL2105 operation using the evaluation software.

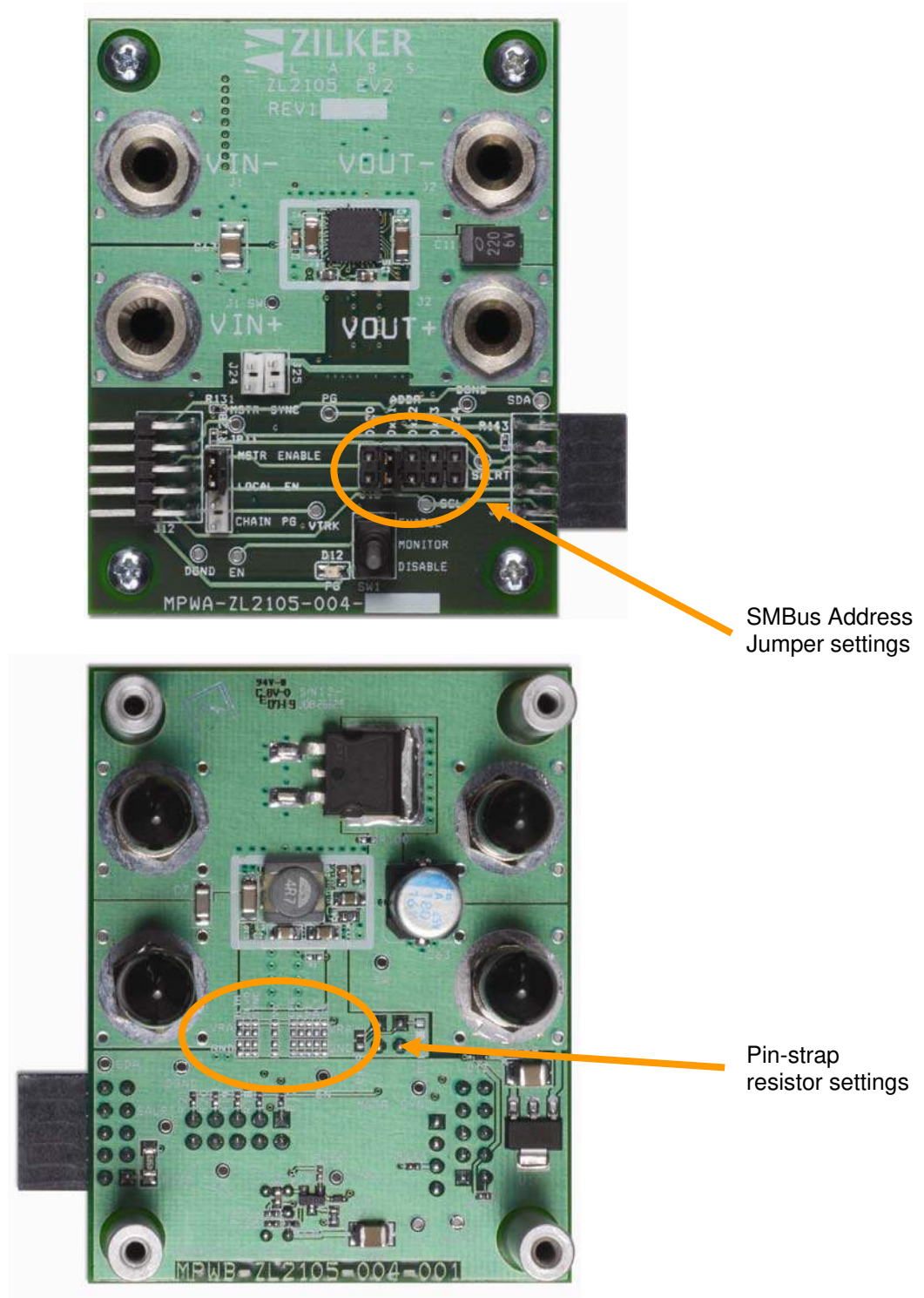
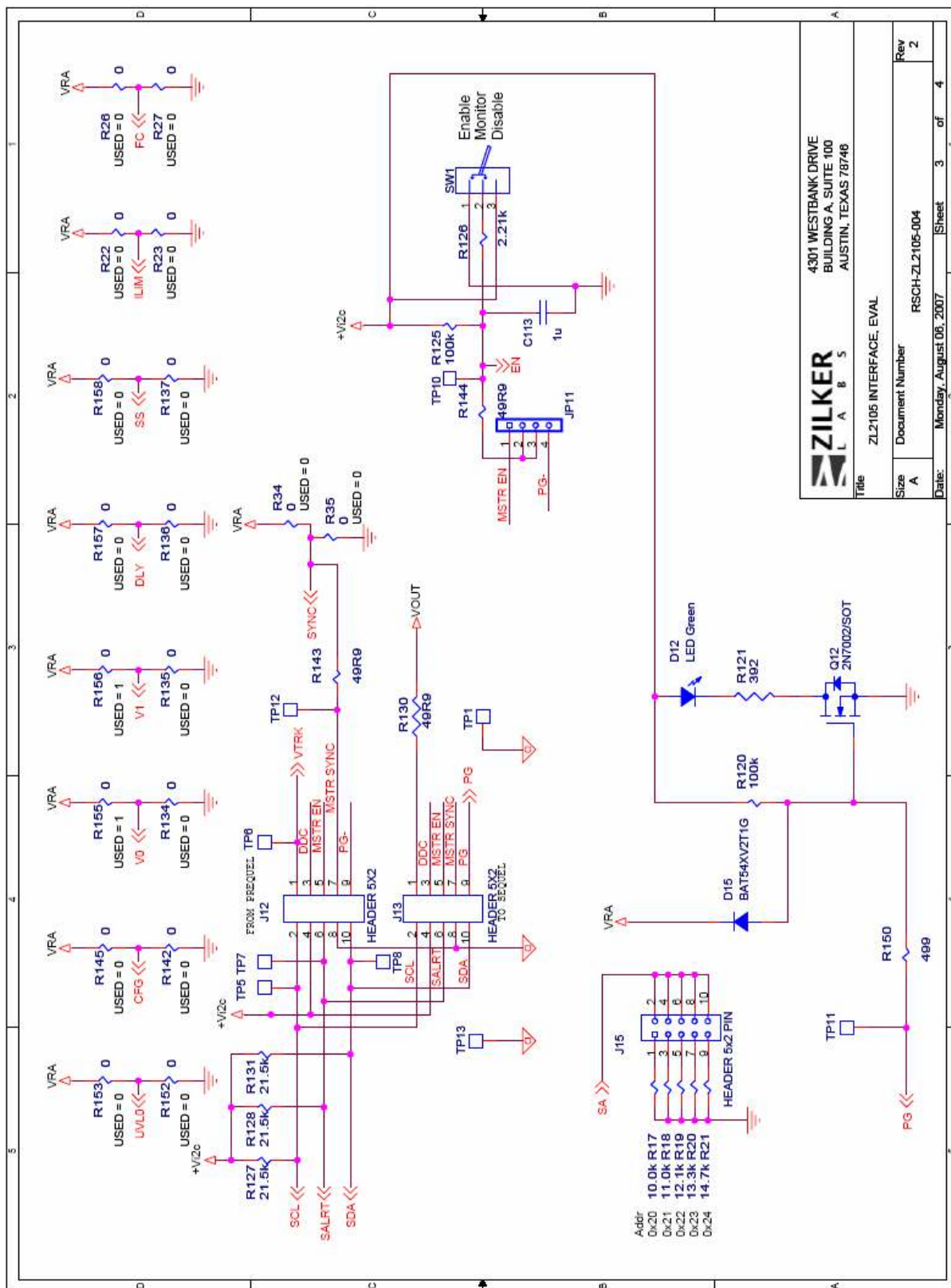

Figure 2. ZL2105EV2 Evaluation Board (Top Side and Bottom Side)







<b>ZILKER</b>		4301 WESTBANK DRIVE BUILDING A, SUITE 100 AUSTIN, TEXAS 78746	
Title: ZL2105 INTERFACE, EVAL			
Size: A	Document Number: RSCH-ZL2105-004	Sheet: 3	of: 4
Date: Monday, August 06, 2007	Rev: 2		

Figure 4. ZL2105EV2 Interface

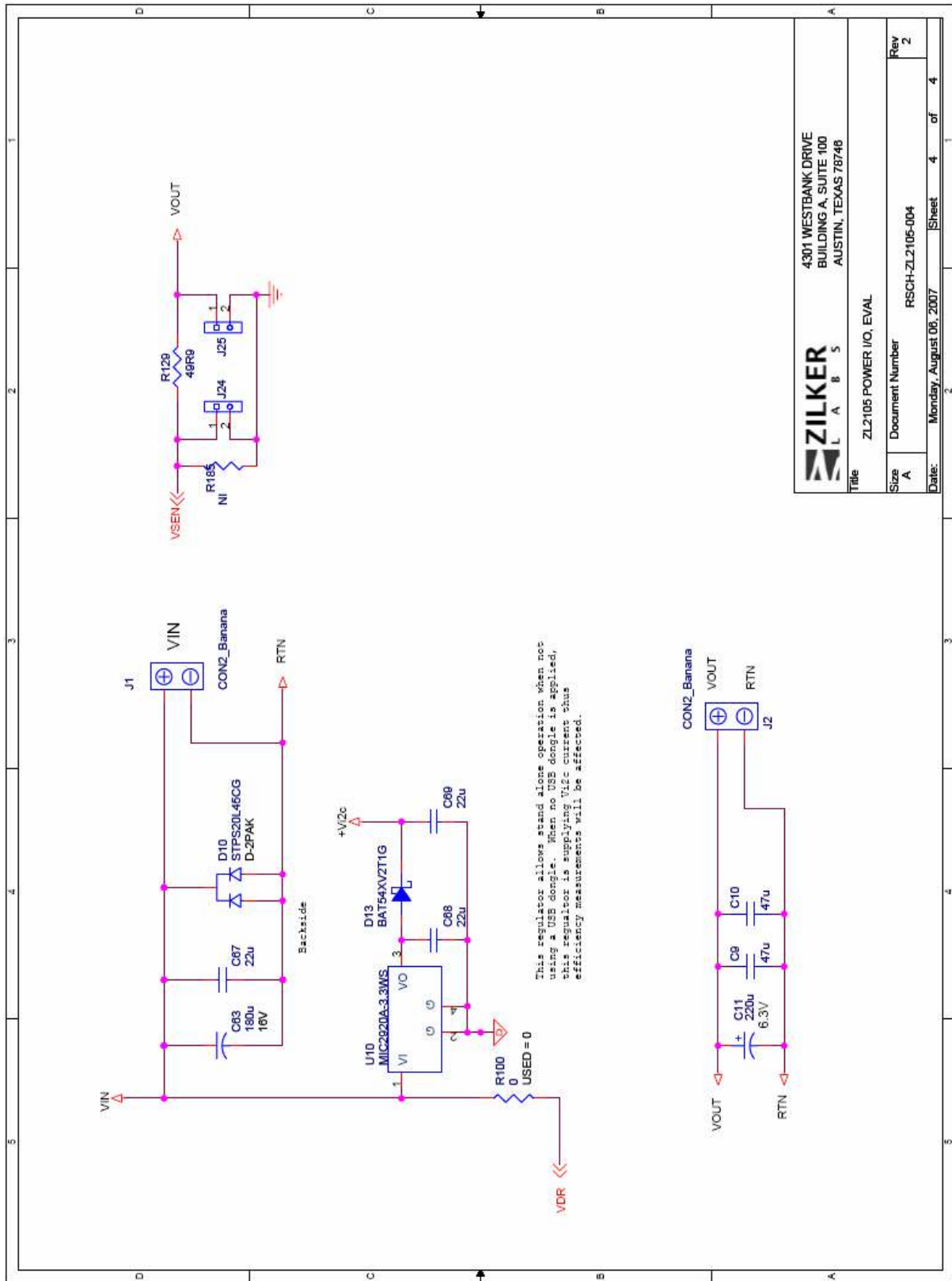

Figure 5. ZL2105EV2 Power I/O

<b>ZILKER</b> L A B S		4301 WESTBANK DRIVE BUILDING A, SUITE 100 AUSTIN, TEXAS 78746	
Title: ZL2105 POWER I/O, EVAL			
Size: A	Document Number: RSCH-ZL2105-004	Rev: 2	Sheet: 4 of 4
Date: Monday, August 06, 2007			



## Board Layout – 4 Layers

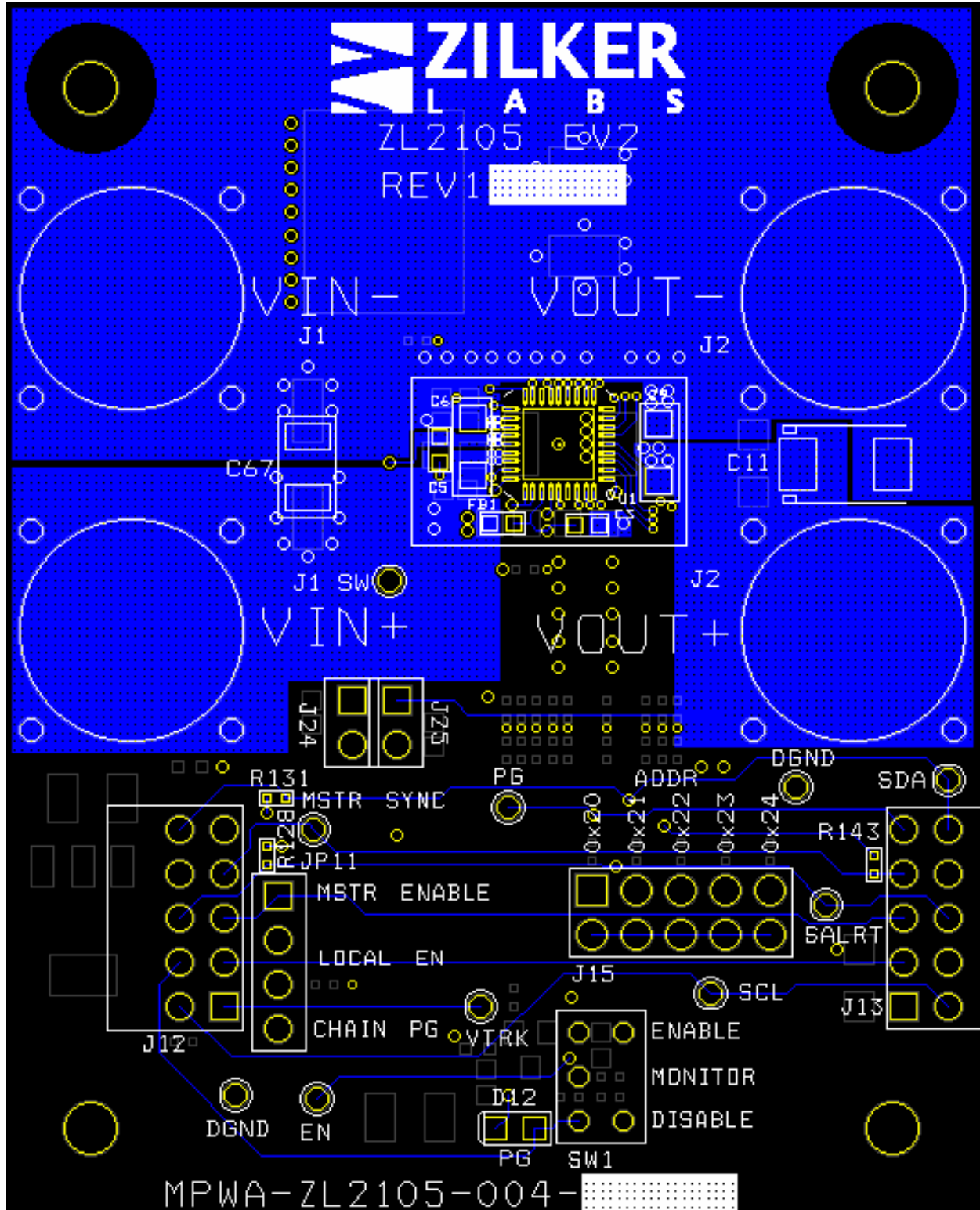

Figure 6. PCB – Top Layer

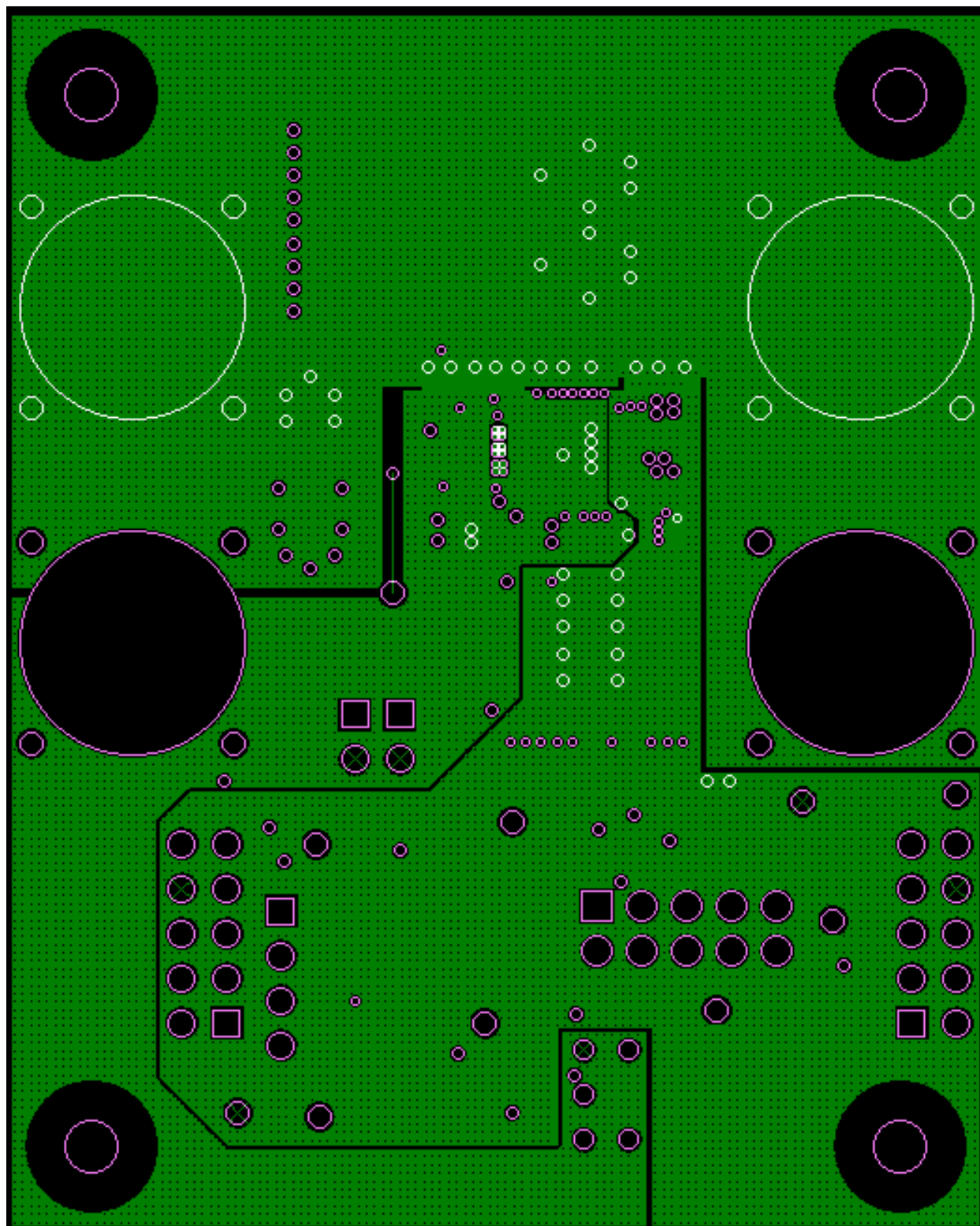

Figure 7. PCB – Inner Layer 1 (Viewed from Top)

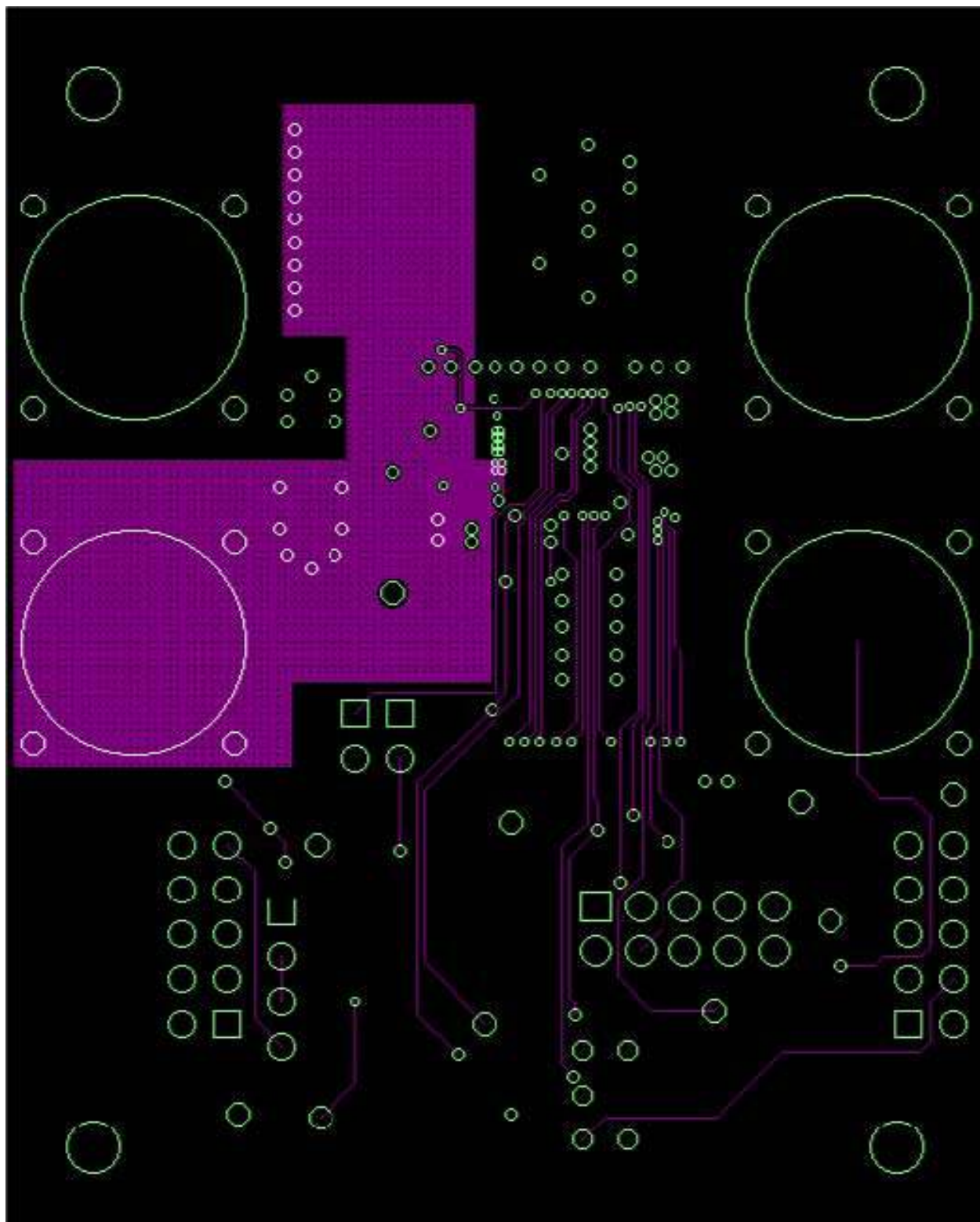

Figure 8. PCB – Inner Layer 2 (Viewed from Top)

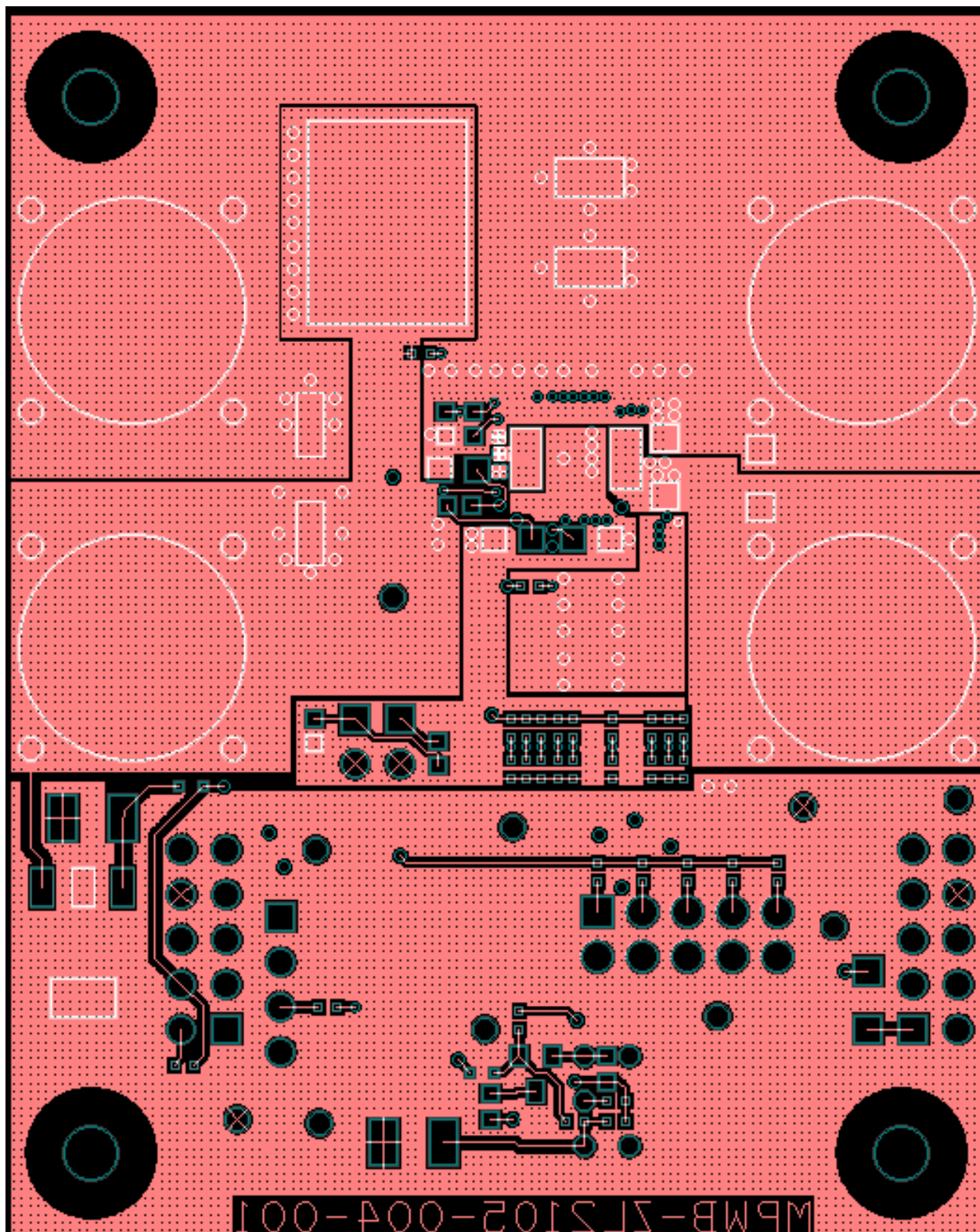

Figure 9. PCB – Bottom Layer (Viewed from Top)

### Typical Performance Data for Buck Regulator

Unless noted:  $V_{in} = 12V$ ,  $V_{out} = 3.3V$ ,  $f_{sw} = 400kHz$ ,  $T_A = +25^\circ C$

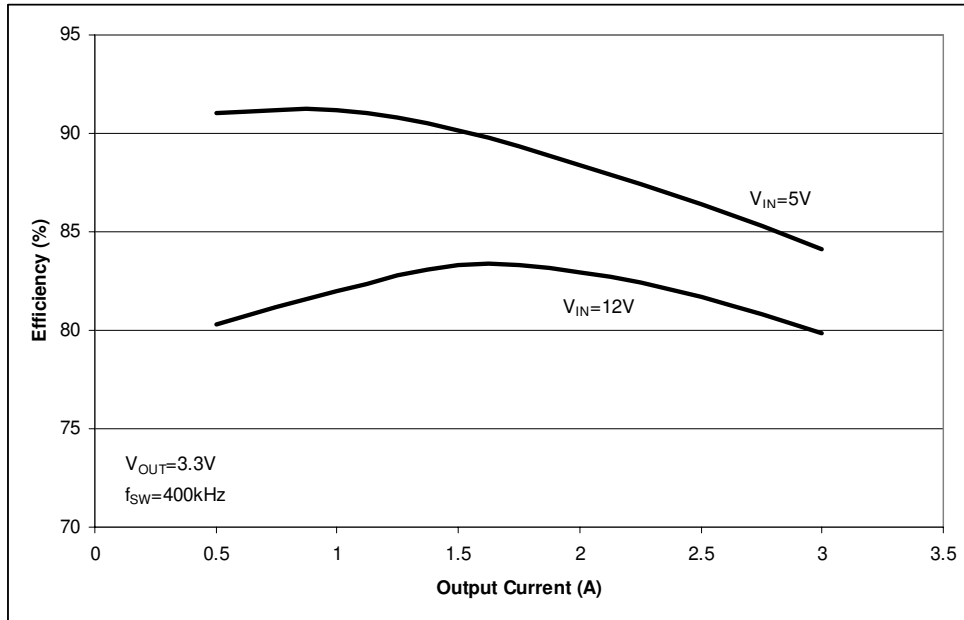

Figure 10. Measured Efficiency

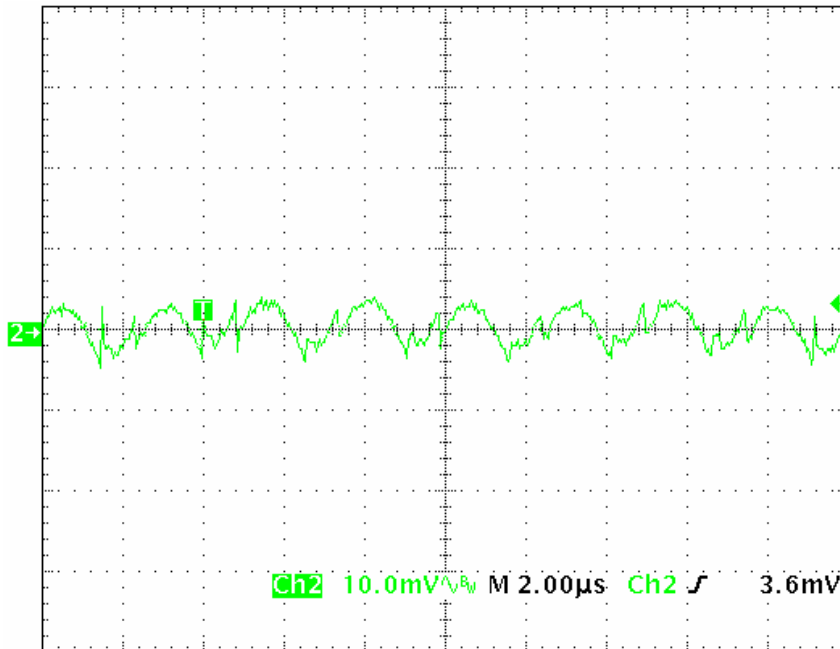

Figure 11. Ripple



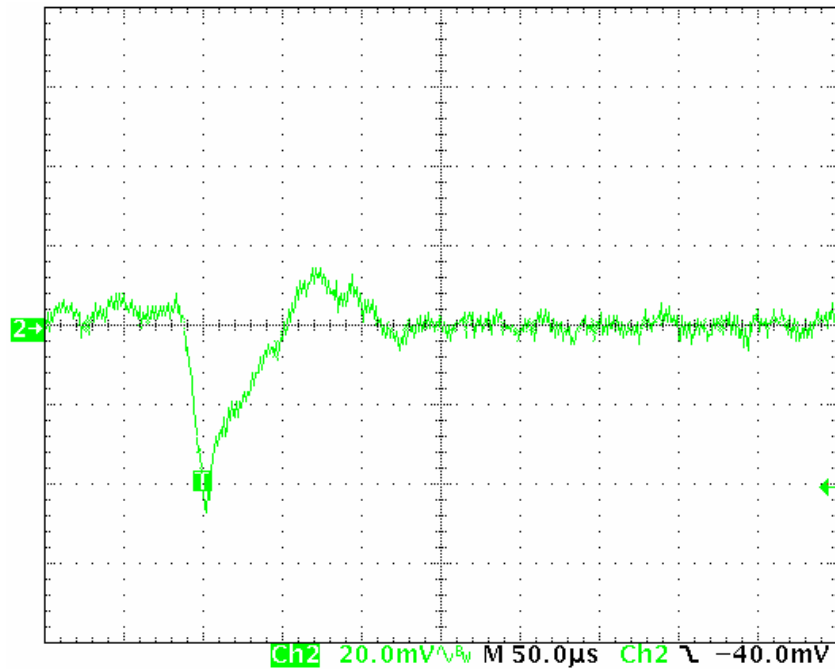

Figure 12. Dynamic Response (1 - 2A load step, di/dt=1A/µs)

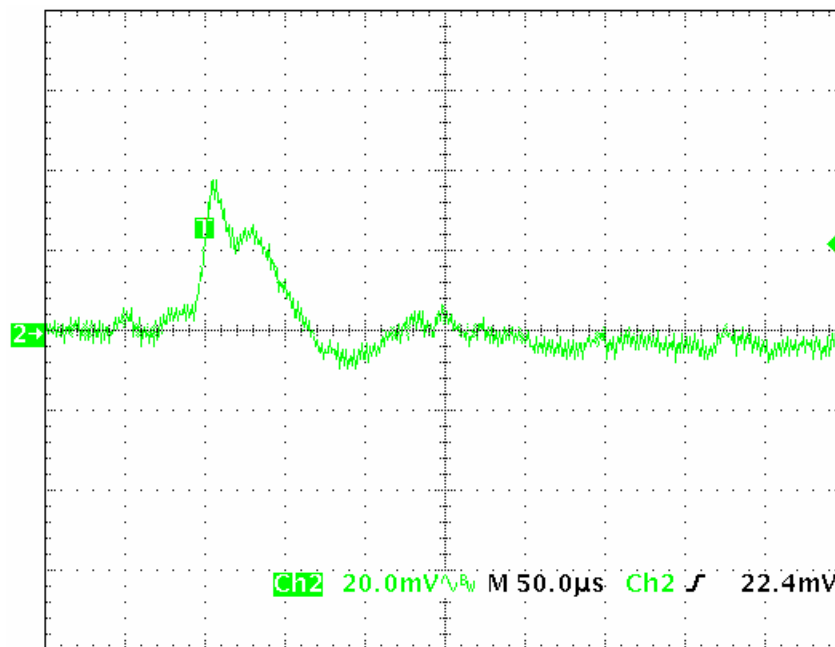

Figure 13. Dynamic Response (2 - 1A load step, di/dt=1A/µs)

## Bill of Materials

ITEM	QTY	REFDES	VALUE	TOL	RATING	TYPE	PCB FOOTPRINT	MFR	MFR PN
1	2	C1,C4	4.7u	20%	10V	X5R	SM0805	PANASONIC-ECG	ECJ-GVB1A475M
2	1	C2	10u	20%	6.3V	X5R	SM0805	MURATA	GRM21BR60J106ME19L
3	1	C3	1u	10%	25V	X5R	SM0603	TAIYO YUDEN	TMK107BJ105KA-T
4	1	C5	47n	10%	25V	X7R	SM0603	AVX	06033C473KAT2A
5	1	C6	10u	20%	16V	X5R	SM1206	TDK	C3216X5R1C106M
6	3	C7,C9,C10	47u	20%	6.3V	X5R	SM1206	TDK	C3216X5R0J476M
7	1	C8	100n	10%	50V	X7R	SM0603	MURATA	GRM188R71H104KA93D
8	1	C11	220u	20%	6.3V	TANT	SM7343	NICHICON	F910J227MNC
9	1	C12	10n	10%	25V	X7R	SM0603	PANASONIC-ECG	ECJ-1VB1E103K
10	1	C63	180u	20%	16V	ELECT POLY	8.3X8.3_PXA_FLD	UCC	APXA160ARA181MHC0G
11	3	C67,C68,C69	22u	10%	16V	X5R	SM1210	MURATA	GRM32ER61C226KE20L
12	1	C113	1u	10%	10V	X7R	SM0603	TAIYO YUDEN	LMK107BJ105KA-T
13	1	D10	STPS20L45CG		45V		D-2PAK	ST MICROELECT	STPS20L45CG
14	1	D12	LED Green		20mA	CLR	SM0805_DIO_1C2A	CHICAGO MINIATURE	CMD17-21VGC
15	2	D13,D15	BAT54XV2T1G		30V	SCHOTTKY	SOD-523	ON SEMI	BAT54XV2T1G
16	1	FB1	1000Z	25%	50mA	MLC	SM0603	MURATA	BLM18HD102SN1D
17	1	JP11	4 PIN			SN	SIP4/100	TYCO	644456-4
18	2	J1,J2	CON2_Banana		15A		JACK_F	EMERSON	108-0740-001
19	1	J12	HEADER 5X2			SN	HDR5DUALRA100X100	SAMTEC	TSW-105-08-T-D-RA
20	1	J13	HEADER 5X2				HDRF5DUALRA100X100	SAMTEC	SSQ-105-02-T-D-RA
21	1	J15	HEADER 5x2 PIN			SN	HDR10DUAL100X100	SAMTEC	TSW-105-07-T-D
22	2	J24,J25	2 PIN			SN	SIP2/100	TYCO	644456-2
23	1	L2	4.7u	20%	3.4A	SH DRUM	IHLP_2525BD	TDK	RLF7030T-4R7M3R4
24	1	Q12	2N7002/SOT		60V	N-CH	SOT-23	ON SEMI	2N7002LT1
25	1	R1	91	1%	100mW	THK FILM	SM0603	ROHM	MCR03EZPFX91R0
27	1	R17	10.0k	1%	63mW	THK FILM	SM0402		
28	1	R18	11.0k	1%	63mW	THK FILM	SM0402		
29	1	R19	12.1k	1%	63mW	THK FILM	SM0402		
30	1	R20	13.3k	1%	63mW	THK FILM	SM0402		
31	1	R21	14.7k	1%	63mW	THK FILM	SM0402		
32	2	R120,R125	100k	1%	63mW	THK FILM	SM0402	YAGEO	RC0402FR-07100KL
33	1	R121	392	1%	100mW	THK FILM	SM0603	YAGEO	RC0603FR-07392RL
34	1	R126	2.21k	1%	63mW	THK FILM	SM0402	YAGEO	RC0402FR-072K21L
35	3	R127,R128,R131	21.5k	1%	63mW	THK FILM	SM0402		
36	1	R129	49R9	1%	100mW	THK FILM	SM0603	ROHM	MCR03EZPFX49R9
37	1	R130	49R9	1%	250mW	THK FILM	SM1206	YAGEO	RC1206FR-0749R9L
38	2	R143,R144	49R9	1%	63mW	THK FILM	SM0402	YAGEO	RC0402FR-0749R9L
39	1	R150	499	1%	63mW	THK FILM	SM0402	YAGEO	RC0402FR-07499L
40	2	R155,R156	0	5%	63mW	THK FILM	SM0402	YAGEO	RC0402JR-070RL
42	1	SW1	SW_SPDT				SW_TOG_SPDT	NKK	G13AP
44	1	U1	ZL2105		3A		MLF36_6X6BX	ZILKER LABS INC	ZL2105ALNFT
45	1	U10	MIC2920A-3.3WS		400mA		SOT223_1234_FLD	MICREL	MIC2920A-3.3WS
47	2	XX8,XX9					SHUNT_HDR_WITH_TAB	TYCO	881545-2
48	4	XX20,XX21,XX22,XX23					STANDOFF_4-40		
49	4	XX24,XX25,XX26,XX27				PHL	SCREW_4-40	BUILDING FASTENERS	PMS 440 0025 PH
50	4	XX30,XX31,XX32,XX33					CAP_MOLDED.25ID	CAPPLUGS	VC-234-8
51	1	XX34	PCB				BDOTLN3.0HX4.0L	ZILKER LABS INC	MPWB-ZL2105-004
NOT INSTALLED:									
26	18	R2,R22,R23,R26,R27,R34,R35,R100,R134,R135,R136,R137,R142,R145,R152,R153,R157,R158	0	5%	63mW	THK FILM	SM0402	YAGEO	RC0402JR-070RL
41	1	R185	NI	1%	100mW	THK FILM	SM0603		
43	10	TP1,TP2,TP5,TP6,TP7,TP8,TP10,TP11,TP12,TP13	T POINT S				TP_036H_REV1		
46	1	XX1	TIEPT/10WIDE				TIEPT/10WIDE		

## Default Configuration Text

The following text is loaded into the ZL2105EV2 as default settings. Each PMBus command is loaded via the ZL2105EV2 interface software. The # symbol is used for a comment line.

```
#ZL2105-002-DB08
#NOTE: This file is intended for the Rev. 1 ZL2105-EV2 with L=4.7uH,
Co=3x(47uF/2.5mohm)+(220uF/250mohm)

#Configuration File Format:
#PMBus Command <tab> Hex Value

#Erase user store & default store
RESTORE_FACTORY
STORE_USER_ALL
STORE_DEFAULT_ALL

#RESPONSES
#low FET not enabled for output OV and UV count to 2
OVUV_CONFIG 0x01

#LIMITS
VIN_UV_FAULT_LIMIT 4.5

#Set output peak/valley current protection to 4.0 to -4.0A
IOUT_OC_FAULT_LIMIT 4
IOUT_UC_FAULT_LIMIT -4

#Set output average current protection to 3.3 to -3.3A
IOUT_AVG_OC_FAULT_LIMIT 3.3
IOUT_AVG_UC_FAULT_LIMIT -3.3

#SETTINGS
#Set Vout to 3.3V
VOUT_COMMAND 3.30000

#Set IOUT_SCALE to 151mOhms
IOUT_SCALE 151

#Set IOUT_OFFSET to -0.4A
IOUT_CAL_OFFSET -0.4A

#Use Rds(on) internal current sense method with internal tempco sensor, delay 512ns, 3 counts
MFR_CONFIG 0x8100

#Set temperature compensation at 400ppm/ C internal temp sensor
TEMPCO_CONFIG 0x04

#Set deadtime to 0ns H-L min dynamic and 16ns L-H fixed
DEADTIME_CONFIG 0x0086
DEADTIME 0x0010

#Loop compensation for 12v:3.3v, ~100mv peak under 1-2A transient @ 2.5A/us, with NLR.
PID_TAPS A=5000, B=-9016, C=4170
#NLR_CONFIG Enable,1.5%,No Outer,1.5%,3,3,0
NLR_CONFIG 0xA250

#Loop compensation for 12V:0.8V, ~20kHz BW, ~60deg PM, ~30mv peak under 0.5A step
#PID_TAPS A=10000, B=-18101, C=8324
#NLR_CONFIG Enable,1.5%,No Outer,2%,3,3,0
NLR_CONFIG 0xA350

STORE_DEFAULT_ALL
RESTORE_DEFAULT_ALL
```

## References

---

- [1] *ZL2105 Data Sheet*, Zilker Labs, Inc., 2008.
- [2] AN10 – *ZL2005 and ZL2105 Thermal and Layout Guideline*, Zilker Labs, Inc., 2006.
- [3] AN13 – *PMBus™ Command Set*, Zilker Labs, Inc., 2007.

## Ordering Information

---

Orderable Part Number	Description
ZL2105EVK2	ZL2105 Evaluation Kit, one channel
ZL2105EV2	ZL2105 Evaluation board only

## Revision History

---

Date	Rev. #	
1-22-08	1.0	Initial Release based on ZL2105EV1 data sheet

## Notice

1. Descriptions of circuits, software and other related information in this document are provided only to illustrate the operation of semiconductor products and application examples. You are fully responsible for the incorporation or any other use of the circuits, software, and information in the design of your product or system. Renesas Electronics disclaims any and all liability for any losses and damages incurred by you or third parties arising from the use of these circuits, software, or information.
  2. Renesas Electronics hereby expressly disclaims any warranties against and liability for infringement or any other claims involving patents, copyrights, or other intellectual property rights of third parties, by or arising from the use of Renesas Electronics products or technical information described in this document, including but not limited to, the product data, drawings, charts, programs, algorithms, and application examples.
  3. No license, express, implied or otherwise, is granted hereby under any patents, copyrights or other intellectual property rights of Renesas Electronics or others.
  4. You shall not alter, modify, copy, or reverse engineer any Renesas Electronics product, whether in whole or in part. Renesas Electronics disclaims any and all liability for any losses or damages incurred by you or third parties arising from such alteration, modification, copying or reverse engineering.
  5. Renesas Electronics products are classified according to the following two quality grades: "Standard" and "High Quality". The intended applications for each Renesas Electronics product depends on the product's quality grade, as indicated below.  
"Standard": Computers; office equipment; communications equipment; test and measurement equipment; audio and visual equipment; home electronic appliances; machine tools; personal electronic equipment; industrial robots; etc.  
"High Quality": Transportation equipment (automobiles, trains, ships, etc.); traffic control (traffic lights); large-scale communication equipment; key financial terminal systems; safety control equipment; etc.  
Unless expressly designated as a high reliability product or a product for harsh environments in a Renesas Electronics data sheet or other Renesas Electronics document, Renesas Electronics products are not intended or authorized for use in products or systems that may pose a direct threat to human life or bodily injury (artificial life support devices or systems; surgical implantations; etc.), or may cause serious property damage (space system; undersea repeaters; nuclear power control systems; aircraft control systems; key plant systems; military equipment; etc.). Renesas Electronics disclaims any and all liability for any damages or losses incurred by you or any third parties arising from the use of any Renesas Electronics product that is inconsistent with any Renesas Electronics data sheet, user's manual or other Renesas Electronics document.
  6. When using Renesas Electronics products, refer to the latest product information (data sheets, user's manuals, application notes, "General Notes for Handling and Using Semiconductor Devices" in the reliability handbook, etc.), and ensure that usage conditions are within the ranges specified by Renesas Electronics with respect to maximum ratings, operating power supply voltage range, heat dissipation characteristics, installation, etc. Renesas Electronics disclaims any and all liability for any malfunctions, failure or accident arising out of the use of Renesas Electronics products outside of such specified ranges.
  7. Although Renesas Electronics endeavors to improve the quality and reliability of Renesas Electronics products, semiconductor products have specific characteristics, such as the occurrence of failure at a certain rate and malfunctions under certain use conditions. Unless designated as a high reliability product or a product for harsh environments in a Renesas Electronics data sheet or other Renesas Electronics document, Renesas Electronics products are not subject to radiation resistance design. You are responsible for implementing safety measures to guard against the possibility of bodily injury, injury or damage caused by fire, and/or danger to the public in the event of a failure or malfunction of Renesas Electronics products, such as safety design for hardware and software, including but not limited to redundancy, fire control and malfunction prevention, appropriate treatment for aging degradation or any other appropriate measures. Because the evaluation of microcomputer software alone is very difficult and impractical, you are responsible for evaluating the safety of the final products or systems manufactured by you.
  8. Please contact a Renesas Electronics sales office for details as to environmental matters such as the environmental compatibility of each Renesas Electronics product. You are responsible for carefully and sufficiently investigating applicable laws and regulations that regulate the inclusion or use of controlled substances, including without limitation, the EU RoHS Directive, and using Renesas Electronics products in compliance with all these applicable laws and regulations. Renesas Electronics disclaims any and all liability for damages or losses occurring as a result of your noncompliance with applicable laws and regulations.
  9. Renesas Electronics products and technologies shall not be used for or incorporated into any products or systems whose manufacture, use, or sale is prohibited under any applicable domestic or foreign laws or regulations. You shall comply with any applicable export control laws and regulations promulgated and administered by the governments of any countries asserting jurisdiction over the parties or transactions.
  10. It is the responsibility of the buyer or distributor of Renesas Electronics products, or any other party who distributes, disposes of, or otherwise sells or transfers the product to a third party, to notify such third party in advance of the contents and conditions set forth in this document.
  11. This document shall not be reprinted, reproduced or duplicated in any form, in whole or in part, without prior written consent of Renesas Electronics.
  12. Please contact a Renesas Electronics sales office if you have any questions regarding the information contained in this document or Renesas Electronics products.
- (Note 1) "Renesas Electronics" as used in this document means Renesas Electronics Corporation and also includes its directly or indirectly controlled subsidiaries.  
(Note 2) "Renesas Electronics product(s)" means any product developed or manufactured by or for Renesas Electronics.

(Rev.4.0-1 November 2017)



### SALES OFFICES

Renesas Electronics Corporation

<http://www.renesas.com>

Refer to "<http://www.renesas.com/>" for the latest and detailed information.

#### Renesas Electronics Corporation

TOYOSU FORESIA, 3-2-24 Toyosu, Koto-ku, Tokyo 135-0061, Japan

#### Renesas Electronics America Inc.

1001 Murphy Ranch Road, Milpitas, CA 95035, U.S.A.  
Tel: +1-408-432-8888, Fax: +1-408-434-5351

#### Renesas Electronics Canada Limited

9251 Yonge Street, Suite 8309 Richmond Hill, Ontario Canada L4C 9T3  
Tel: +1-905-237-2004

#### Renesas Electronics Europe Limited

Dukes Meadow, Millboard Road, Bourne End, Buckinghamshire, SL8 5FH, U.K  
Tel: +44-1628-651-700

#### Renesas Electronics Europe GmbH

Arcadiastrasse 10, 40472 Düsseldorf, Germany  
Tel: +49-211-6503-0, Fax: +49-211-6503-1327

#### Renesas Electronics (China) Co., Ltd.

Room 1709 Quantum Plaza, No.27 ZhichunLu, Haidian District, Beijing, 100191 P. R. China  
Tel: +86-10-8235-1155, Fax: +86-10-8235-7679

#### Renesas Electronics (Shanghai) Co., Ltd.

Unit 301, Tower A, Central Towers, 555 Langao Road, Putuo District, Shanghai, 200333 P. R. China  
Tel: +86-21-2226-0888, Fax: +86-21-2226-0999

#### Renesas Electronics Hong Kong Limited

Unit 1601-1611, 16/F., Tower 2, Grand Century Place, 193 Prince Edward Road West, Mongkok, Kowloon, Hong Kong  
Tel: +852-2265-6688, Fax: +852 2886-9022

#### Renesas Electronics Taiwan Co., Ltd.

13F, No. 363, Fu Shing North Road, Taipei 10543, Taiwan  
Tel: +886-2-8175-9600, Fax: +886 2-8175-9670

#### Renesas Electronics Singapore Pte. Ltd.

80 Bendemeer Road, Unit #06-02 Hyflux Innovation Centre, Singapore 339949  
Tel: +65-6213-0200, Fax: +65-6213-0300

#### Renesas Electronics Malaysia Sdn.Bhd.

Unit 1207, Block B, Menara Amcorp, Amcorp Trade Centre, No. 18, Jln Persiaran Barat, 46050 Petaling Jaya, Selangor Darul Ehsan, Malaysia  
Tel: +60-3-7955-9390, Fax: +60-3-7955-9510

#### Renesas Electronics India Pvt. Ltd.

No.777C, 100 Feet Road, HAL 2nd Stage, Indiranagar, Bangalore 560 038, India  
Tel: +91-80-67208700, Fax: +91-80-67208777

#### Renesas Electronics Korea Co., Ltd.

17F, KAMCO Yangjae Tower, 262, Gangnam-daero, Gangnam-gu, Seoul, 06265 Korea  
Tel: +82-2-558-3737, Fax: +82-2-558-5338