

PART NO.	ENG. NO.	PACKAGING
02-06-1131	1855-(P901)	18550000-PK
02-06-1132	1855-(P901)L	PK-1190-003
02-06-5138	1855-(P561)	18550000-PK
02-06-5139	1855-(P561)L	PK-1190-003
02-06-5130	1855-(P550)	18550000-PK
02-06-5135	1855-(P550)L	PK-1190-003
02-06-5147	1855-(P228)	18550000-PK
02-06-5148	1855-(P228)L	PK-1190-003
02-06-1141	1855-1(P901)	18550000-PK
NOT TOOLED	1855-1(P901)L	PK-1190-003
02-06-1143	1855-(P901)1	PK-18550001-PK

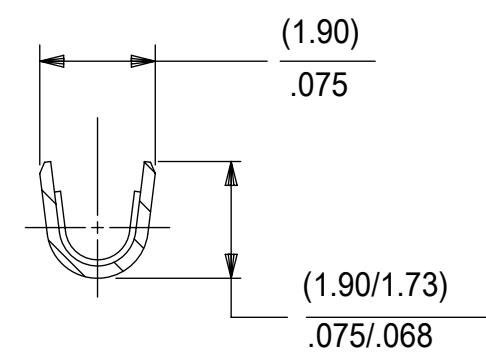

SECT. "B-B"

SCALE:10X

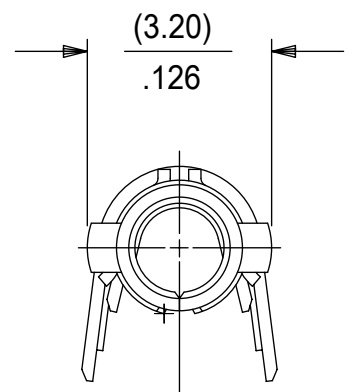
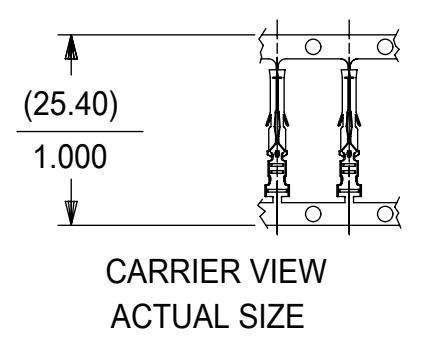
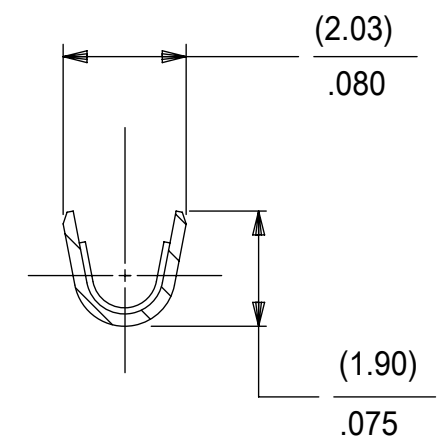

SECT. "C-C"

SCALE:10X

LEGEND

1855-*(***)*

BLANK=WITH LOCKING TABS
1=WITHOUT LOCKING TABS

P=PREPLATE
BLANK=POSTPLATE

FORM
BLANK=CHAIN
1=CHAIN WITH INTERLEAF
PAPER ON REEL.
L=LOOSE
FINISH CODE

- NOTES:
- MATERIAL: BRASS
 - FINISHES:
 - 901 HOT TIN DIP (.00051)/.000020 MIN.
 - 228 SELECT GOLD PLATE (.00075)/.000030 MIN. IN CONTACT AREA, SELECT TIN (.00250)/.000100 MIN. IN CRIMP AREA OVER (.00125)/.000050 MIN. NICKEL OVERALL
 - 561 SELECT GOLD PLATE (.00076)/.000030 MIN. IN CONTACT AREA, (.00127)/.000050 MIN. NICKEL OVERALL.
 - 550 SELECT GOLD PLATE (.00038)/.000015 MIN. IN CONTACT AREA, OVER (.00076)/.000030 MIN. NICKEL OVERALL WITH (.00025)/.000010 MAX. GOLD FLASH OVERALL.
 - PRODUCT SPECIFICATION: PS-02-06
 - PACKAGE INFORMATION: SEE CHART
 - TERMINAL FOR USE WITH (1.57)/.062 DIA. SERIES HOUSINGS AND WILL ACCEPT 24 THRU 30 AWG WIRE WITH (1.02/2.29)/.040/.090 INSULATION DIAMETER.
 - PARTS CONFORM TO CLASS B REQUIREMENTS OF COSMETIC SPECIFICATION PS-45499-002.
 - MARKING MAY VARY ON PARTS, CONSULT FACTORY.
 - TIP GEOMETRY IS TOOL DEPENDENT. EITHER GEOMETRY IS ACCEPTABLE.

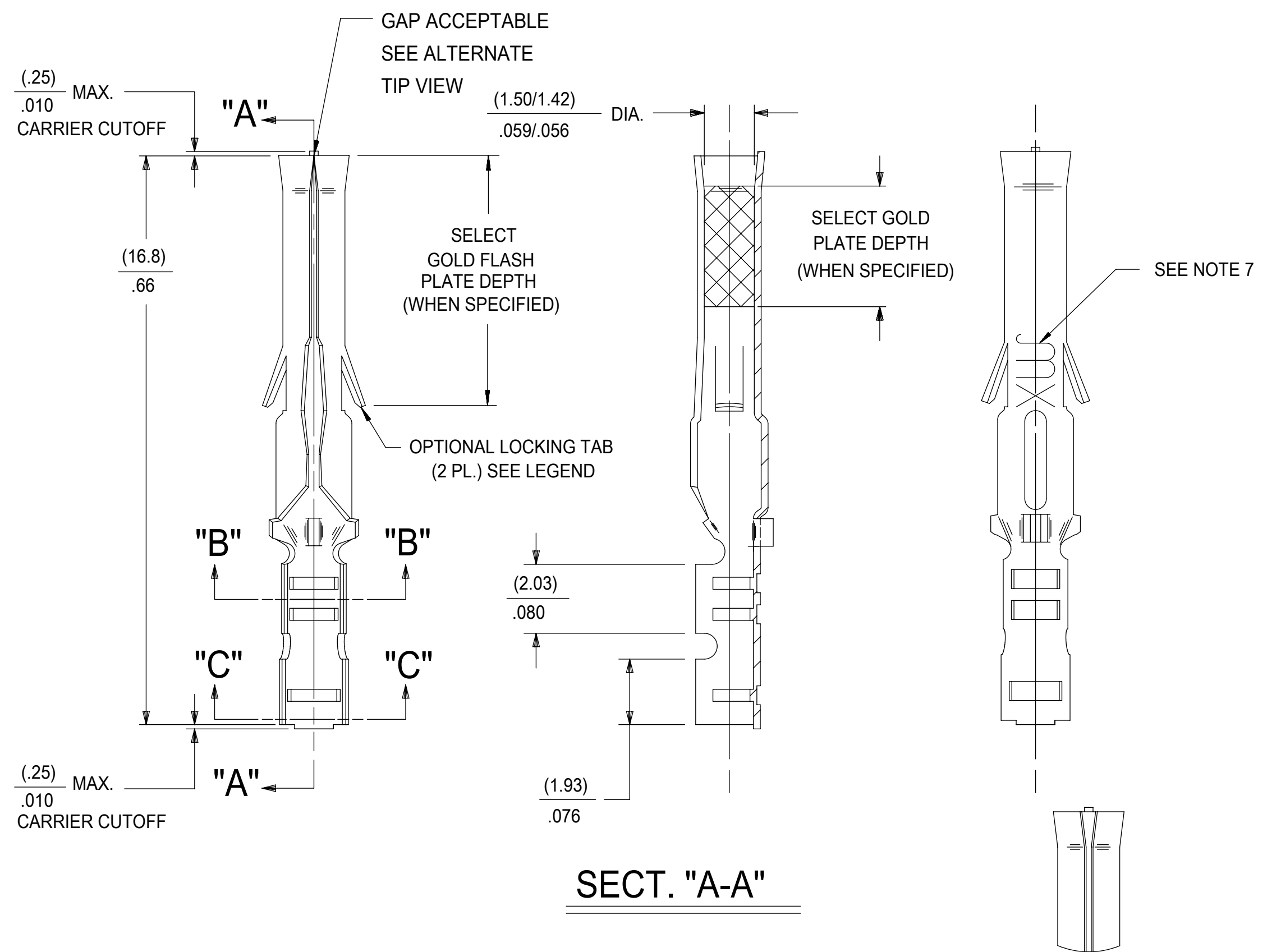

SECT. "A-A"

ALTERNATE TIP GEOMETRY
SEE NOTE 8

SYMBOLS	THIS DRAWING CONTAINS INFORMATION THAT IS PROPRIETARY TO MOLEX ELECTRONIC TECHNOLOGIES, LLC AND SHOULD NOT BE USED WITHOUT WRITTEN PERMISSION			
	DIMENSION UNITS	SCALE		CURRENT REV DESC: ADD CHAIN PK SPEC
∅ = 0	MM/IN	NTS		EC NO: 614240 DRWN: JEHRISMAN 2019/03/22 CHK'D: FSMITH 2019/05/10 APPR: FSMITH 2019/05/10
∇ = 0	GENERAL TOLERANCES (UNLESS SPECIFIED)			
∇ = 0		MM	INCH	INITIAL REVISION: DRWN: GEP 1987/09/17 APPR: RAS 1987/09/17
∇ = 0	4 PLACES	±	±	
∇ = 0	3 PLACES	±	± 0.01	SERIES 1855
∇ = 0	2 PLACES	± 0.25	± 0.014	
∇ = 0	1 PLACE	± 0.35	±	DRAWING C-SIZE
∇ = 0	0 PLACES	±	±	
∇ = 0	ANGULAR TOL	± 0.5 °		SHEET NUMBER 1 OF 1
∇ = 0	DRAFT WHERE APPLICABLE MUST REMAIN WITHIN DIMENSIONS			
∇ = 0	THIRD ANGLE PROJECTION		DRAWING	CUSTOMER GENERAL MARKET

molex

CRIMP TERMINAL, FEMALE
(1.57)/.062 DIA., BRASS FOR 24 THRU 30 GA. WIRE

PRODUCT CUSTOMER DRAWING

DOCUMENT NUMBER	DOC TYPE	DOC PART	REVISION
SD-1855-X	PSD	001	AP3