

TLV320AIC3105EVM and TLV320AIC3105EVM-PDK

This User's Guide describes the characteristics, operation, and use of the TLV320AIC3105EVM, both by itself and as part of the TLV320AIC3105EVM-PDK. This evaluation module (EVM) is a complete stereo audio codec with several inputs and outputs, extensive audio routing, mixing, and effects capabilities. A complete circuit description, schematic diagram, and bill of materials are also included.

The following related documents are available through the Texas Instruments website at www.ti.com.

EVM-Compatible Device Data Sheets

Device	Literature Number
TLV320AIC3105	SLAS513
TAS1020B	SLES025
REG1117-3.3	SBVS001
TPS767D318	SLVS209
SN74LVC125A	SCAS290
SN74LVC1G125	SCES223
SN74LVC1G07	SCES296

Contents

1	EVM Overview	3
2	EVM Description and Basics	3
3	TLV320AIC3105EVM-PDK Setup and Installation	8
4	TLV320AIC3105EVM Software	10
Appendix A	EVM Connector Descriptions	33
Appendix B	TLV320AIC3105EVM Schematic	37
Appendix C	TLV320AIC3105EVM Layout Views	38
Appendix D	TLV320AIC3105EVM Bill of Materials	41
Appendix E	USB-MODEVM Schematic	42
Appendix F	USB-MODEVM Layout Views	44
Appendix G	USB-MODEVM Bill of Materials	46
Appendix H	USB-MODEVM Protocol	48

List of Figures

1	TLV320AIC3105EVM-PDK Block Diagram	4
2	Default Software Screen	9
3	Device Selection Window	10
4	Preset Configuration Tab	12
5	Audio Input/ADC Tab	13
6	Bypass Paths Tab	14
7	Audio Interface Tab	15
8	Clocks Tab	16
9	AGC Tab	18

Microsoft, Windows are registered trademarks of Microsoft Corporation.
 SPI is a trademark of Motorola, Inc.
 VISA, LabVIEW are trademarks of National Instruments Corporation.
 All other trademarks are the property of their respective owners.

10	Left AGC Settings	19
11	Advanced	19
12	Filters Tab	20
13	ADC High-Pass Filters	21
14	ADC High-Pass Filter Settings	21
15	DAC Filters	22
16	De-emphasis Filters	22
17	Enabling Filters	23
18	Shelf Filters	23
19	EQ Filters	24
20	Analog Simulation Filters	24
21	Preset Filters	25
22	User Filters	25
23	3D Effect Settings	26
24	Output Stage Configuration Tab	27
25	DAC/Line Outputs Tab	28
26	High Power Outputs Tab	30
27	Command Line Interface Tab	31
28	File Menu	32
29	TLV320AIC3105EVM Assembly Layer	38
30	TLV320AIC3105EVM Top Layer	38
31	TLV320AIC3105EVM Layer 3	39
32	TLV320AIC3105EVM Layer 4	39
33	TLV320AIC3105EVM Silk Screen.....	40
34	TLV320AIC3105EVM Bottom Layer	40
35	USB-MODEVM Interface Board Schematic (1 of 2)	42
36	USB-MODEVM Interface Board Schematic (2 of 2)	43
37	USB-MODEVM Assembly Layer	44
38	USB-MODEVM Top Layer	44
39	USB-MODEVM Bottom Layer	45

List of Tables

1	USB-MODEVM SW2 Settings.....	5
2	USB-MODEVM Jumpers.....	5
3	List of Jumpers	6
4	Analog Interface Pinout.....	33
5	Alternate Analog Connectors	34
6	Digital Interface Pinout.....	35
7	Power Supply Pinout.....	36
8	TLV320AIC3105EVM Bill of Materials	41
9	USB-MODEVM Bill of Materials	46
10	USB Control Endpoint HIDSETREPORT Request.....	48
11	Data Packet Configuration	48
12	GPIO Pin Assignments	51

1 EVM Overview

1.1 Features

- Full-featured evaluation board for the TLV320AIC3105 stereo audio codec.
- Modular design for use with a variety of digital signal processor (DSP) and microcontroller interface boards.
- USB connection to PC provides power, control, and streaming audio data for easy evaluation.
- Onboard microphone for ADC evaluation
- Connection points for external control and digital audio signals for quick connection to other circuits/input devices.

The TLV320AIC3105EVM-PDK is a complete evaluation kit, which includes a universal serial bus (USB)-based motherboard and evaluation software for use with a personal computer running the Microsoft® Windows® operating system (Windows 2000, Windows XP, or Windows 7).

1.2 Introduction

The TLV320AIC3105EVM is in the Texas Instruments modular EVM form factor, which allows direct evaluation of the device performance and operating characteristics, and eases software development and system prototyping. This EVM is compatible with the 5-6K Interface Evaluation Module ([SLAU104](#)) and the HPA-MCUINTERFACE ([SLAU106](#)) from Texas Instruments and additional third-party boards which support TI's Modular EVM format.

The TLV320AIC3105EVM-PDK is a complete evaluation/demonstration kit, which includes a USB-based motherboard called the USB-MODEVM interface board and evaluation software for use with a personal computer running the Microsoft Windows operating systems.

The TLV320AIC3105EVM-PDK is operational with one USB cable connection to a personal computer. The USB connection provides power, control, and streaming audio data to the EVM for reduced setup and configuration. The EVM also allows external control signals, audio data, and power for advanced operation, which allows prototyping and connection to the rest of the development or system evaluation.

2 EVM Description and Basics

This section provides information on the analog input and output, digital control, power and general connection of the TLV320AIC3105EVM.

2.1 TLV320AIC3105EVM-PDK Block Diagram

The TLV320AIC3105EVM-PDK consists of two separate circuit boards, the USB-MODEVM and the TLV320AIC3105EVM. The USB-MODEVM is built around a TAS1020B streaming audio USB controller with an 8051-based core. The motherboard features two positions for modular EVMs, or one double-wide serial modular EVM may be installed. The TLV320AIC3105EVM is one of the double-wide modular EVMs that is designed to work with the USB-MODEVM.

The simple diagram in [Figure 1](#) shows how the TLV320AIC3105EVM is connected to the USB-MODEVM. The USB-MODEVM interface board is intended to be used in USB mode, where control of the installed EVM is accomplished using the onboard USB controller device. Provision is made, however, for driving all the data buses (I²C, SPI™, I²S/AC97) externally. The source of these signals is controlled by SW2 on the USB-MODEVM. See [Table 1](#) for details on the switch settings.

The USB-MODEVM has two EVM positions that allow for the connection of two small evaluation module or one larger evaluation module. The TLV320AIC3105EVM is designed to fit over both of the smaller evaluation module slots as shown in [Section 2.2](#).

2.1.1 USB-MODEVM Interface Board

The simple diagram shown in [Figure 1](#) shows only the basic features of the USB-MODEVM interface board.

Because the TLV320AIC3105EVM is a double-wide modular EVM, it is installed with connections to both EVM positions, which connects the TLV320AIC3105 digital control interface to the I²C port realized using the TAS1020B, as well as the TAS1020B digital audio interface.

In the factory configuration, the board is ready to use with the TLV320AIC3105EVM. To view all the functions and configuration options available on the USB-MODEVM board, see the USB-MODEVM interface board schematic in [Appendix E](#).

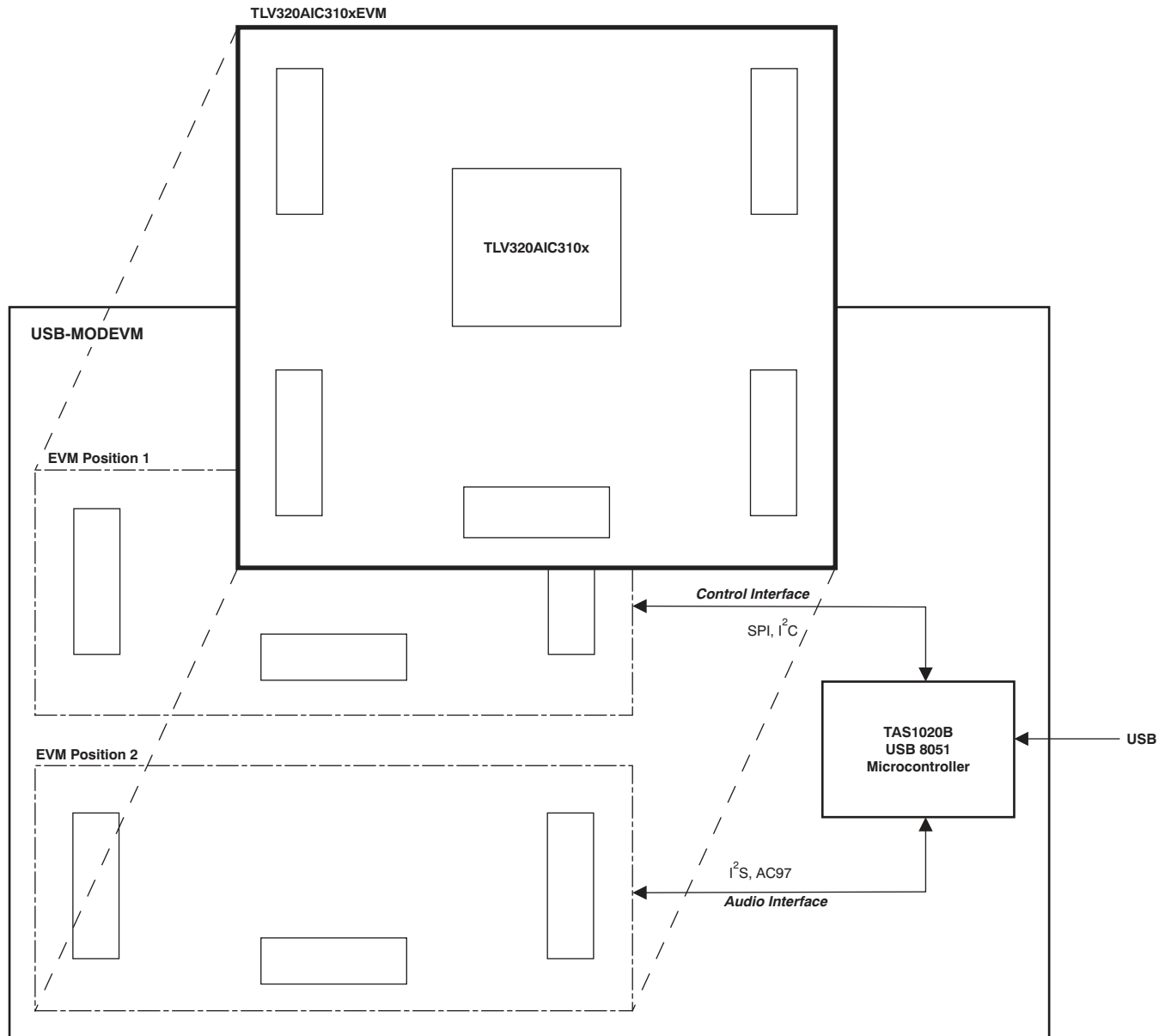

Figure 1. TLV320AIC3105EVM-PDK Block Diagram

2.2 Default Configuration and Connections

2.2.1 USB-MODEVM

Table 1 provides a list of the SW2 settings on the USB=MODEVM. For use with the TLV320AIC3105EVM, SW-2 positions 1 through 7 should be set to ON, while SW-2.8 should be set to OFF.

Table 1. USB-MODEVM SW2 Settings

SW-2 Switch Number	Label	Switch Description
1	A0	USB-MODEVM EEPROM I ² C Address A0 ON: A0 = 0 OFF: A0 = 1
2	A1	USB-MODEVM EEPROM I ² C Address A1 ON: A1 = 0 OFF: A1 = 1
3	A2	USB-MODEVM EEPROM I ² C Address A2 ON: A2 = 0 OFF: A2 = 1
4	USB I ² S	I ² S Bus Source Selection ON: I ² S Bus connects to TAS1020 OFF: I ² S Bus connects to USB-MODEVM J14
5	USB MCK	I ² S Bus MCLK Source Selection ON: MCLK connects to TAS1020 OFF: MCLK connects to USB-MODEVM J14
6	USB SPI	SPI Bus Source Selection ON: SPI Bus connects to TAS1020 OFF: SPI Bus connects to USB-MODEVM J15
7	USB RST	RST Source Selection ON: EVM Reset Signal comes from TAS1020 OFF: EVM Reset Signal comes from USB-MODEVM J15
8	EXT MCK	External MCLK Selection ON: MCLK Signal is provided from USB-MODEVM J10 OFF: MCLK Signal comes from either selection of SW2-5

Table 2 provides a list of USB-MODEVM jumpers found on the EVM.

Table 2. USB-MODEVM Jumpers

Jumper	Default Position	Jumper Description
JMP1	Installed	Connects analog and digital +5 V supplies
JMP2	Open	Connects analog and digital grounds
JMP3	Open	Connects I2C SDA pull-up to IOVDD
JMP4	Open	Connects I2C SCL pull-up to IOVDD
JMP5	2-3	When connecting 2-3, /SS comes from FSX; when connecting 1-2, /SS comes from CNTL
JMP6	1-2	When connecting 1-2, +5 VD comes from USB; when connecting 2-3, +5 VD comes from U2
JMP7	1-2	When connecting 1-2, MCLKI comes from USB; when connecting 2-3, MCLKI comes from AVSS/DVSS
JMP8	Open	Connects resistor across EXT MCLK

Windows 7 Instructions

For use of the MODEVM motherboard on Windows 7 machines, the most up-to-date version of National Instrument's VISA™ drivers must be installed (ni.com). After this is installed, the USB-MODEVM Windows XP/Windows Vista/Windows 7 driver must also be installed ([SLAC521](#)).

2.2.2 TLV320AIC3105 Jumper Locations

Table 3 provides a list of jumpers found on the EVM and their factory default conditions.

Table 3. List of Jumpers

Jumper	Default Position	Jumper Description
JMP1	Installed	Connects analog and digital grounds
JMP2	Open	Selects onboard EEPROM as firmware source
JMP3	Installed	Connects onboard Mic to IN3L
JMP4	Installed	Connects onboard Mic to IN3R
JMP5	Installed	Provides a means of measuring IOVDD current
JMP6	Installed	Provides a means of measuring DVDD current
JMP7	Installed	Provides a means of measuring DRVDD current
JMP8	Installed	Provides a means of measuring AVDD_DAC current
JMP9	Open	When installed, allows the USB-MODEVM to hardware reset the device under user control
JMP10	2-3	When connecting 2-3, mic bias comes from the MICBIAS pin on the device; when connecting 1-2, mic bias is supplied from the power supply through a resistor, which the user must install
JMP11	Installed	When installed, shorts across the output capacitor on HPLOUT; remove this jumper if using AC-coupled output drive
JMP12	Installed	When installed, shorts HPLCOM and HPRCOM. Use only if these signals are set to constant VCM.
JMP13	Installed	When installed, shorts across the output capacitor on HPLCOM; remove this jumper if using AC-coupled output drive
JMP14	Installed	When installed, shorts across the output capacitor on HPROUT; remove this jumper if using AC-coupled output drive
JMP15	Installed	When installed, shorts across the output capacitor on HPRCOM; remove this jumper if using AC-coupled output drive
JMP16	2-3	When connecting 2-3, IOVDD is set to +3.3VD; when connecting 1-2, IOVDD and DVDD are shorted at +1.8 VD

2.3 Analog Signal Connections

2.3.1 Analog Inputs

The analog inputs to the EVM can be connected through two different methods. The analog input sources can be applied directly to J1 (top or bottom side) or through the analog headers (J6-8 and J14) around the edge of the board. The connection details of each header/connector can be found in Appendix A.

2.3.2 Analog Output

The analog outputs to the EVM can be connected through two different methods. The analog outputs are available from the J1 and J2 (top or bottom) or they may be accessed through J9, J10, J11, J12, and J13 at the edges of the board. The connection details can be found in Appendix A.

2.4 Digital Signal Connections

2.4.1 Digital Inputs and Outputs

The digital inputs and outputs of the EVM can be monitored through J4 and J5. If external signals need to be connected to the EVM, digital inputs should be connected via J14 and J15 on the USB-MODEVM and the SW2 switch should be changed accordingly (see [Section 2.2.1](#)). The connector details are available in Appendix A.2.

2.4.2 Digital Controls

The digital control signals can be applied directly to J4 and J5 (top or bottom side). The modular TLV320AIC3105EVM can also be connected directly to a DSP interface board, such as the 5-6KINTERFACE or HPA-MCUINTERFACE, or to the USB-MODEVM interface board if purchased as part of the TLV320AIC3105EVM-PDK. See the [AIC3105](#) product folder for this EVM or the TLV320AIC3105 for a current list of compatible interface and/or accessory boards.

2.5 Power Connections

The TLV320AIC3105EVM can be powered independently when being used in stand-alone operation or by the USB-MODEVM when it is plugged onto the motherboard.

2.5.1 Stand-Alone Operation

When used as a stand-alone EVM, power is applied to J3 directly, making sure to reference the supplies to the appropriate grounds on that connector.

CAUTION

Verify that all power supplies are within the safe operating limits shown on the [TLV320AIC3105](#) data sheet before applying power to the EVM.

J3 provides connection to the common power bus for the TLV320AIC3105EVM. Power is supplied on the pins listed in [Table 7](#).

The TLV320AIC3105EVM-PDK motherboard (the USB-MODEVM interface board) supplies power to J3 of the TLV320AIC3105EVM. Power for the motherboard is supplied either through its USB connection or via terminal blocks on that board.

2.5.2 USB-MODEVM Operation

The USB-MODEVM interface board can be powered from several different sources:

- USB
- 6-Vdc to 10-Vdc AC/DC external wall supply (not included)
- Lab power supply

When powered from the USB connection, JMP6 should have a shunt from pins 1–2 (this is the default factory configuration). When powered from 6 V to 10 Vdc, either through the J8 terminal block or J9 barrel jack, JMP6 should have a shunt installed on pins 2–3. If power is applied in any of these ways, onboard regulators generate the required supply voltages and no further power supplies are necessary.

If lab supplies are used to provide the individual voltages required by the USB-MODEVM interface, JMP6 should have no shunt installed. Voltages are then applied to J2 (+5VA), J3 (+5VD), J4 (+1.8VD), and J5 (+3.3VD). The +1.8VD and +3.3VD can also be generated on the board by the onboard regulators from the +5VD supply; to enable this configuration, the switches on SW1 need to be set to enable the regulators by placing them in the ON position (lower position, looking at the board with text reading right-side up). If +1.8VD and +3.3VD are supplied externally, disable the onboard regulators by placing SW1 switches in the OFF position.

Each power supply voltage has an LED (D1-D7) that lights when the power supplies are active.

3 TLV320AIC3105EVM-PDK Setup and Installation

The following section provides information on using the TLV320AIC3105EVM-PDK, including set up, program installation, and program usage.

NOTE: If using the EVM in stand-alone mode, the software should be installed per the following section, but the hardware configuration may be different.

3.1 Software Installation

1. Locate installation file on the CD-ROM include with the EVM or download the latest version of the software located on the [AIC3105](#) product page. If downloading the software from the Ti Web site, an option is available to allow the user to be notified when the software is updated.
2. Unzip the installation file by clicking on the self-extracting zip file.
3. Install the EVM software by double-clicking the **Setup** executable and follow the directions. The user may be prompted to restart their computer.

This should install all the TLV320AIC310x software and required drivers onto their PC.

3.2 EVM Connections

1. Ensure that the TLV320AIC3105EVM is installed on the USB-MODEVM interface board, aligning J1, J2, J3, J4, and J5 with the corresponding connectors on the USB-MODEVM.
2. Verify that the jumpers and switches are in their default conditions.
3. Attach a USB cable from the PC to the USB-MODEVM interface board. The default configuration will provide power, control signals, and streaming audio via the USB interface from the PC. On the USB-MODEVM, LEDs D3-6 should light to indicate the power is being supplied from the USB.
4. For the first connection, the PC should recognize new hardware and begin an initialization process. The user may be prompted to identify the location of the drivers or allow the PC to automatically search for them. Allow the automatic detection option.
5. Once the PC confirms that the hardware is operational, D2 on the USB-MODEVM should light to indicate that the firmware has been loaded and the EVM is ready for use. If the LED is not lite, verify that the drivers were installed and trying to unplug and restart at Step 3.

After the TLV320AIC310x software installation (described in [Section 3.1](#)) is complete, evaluation and development with the TLV320AIC3105 can begin.

The TLV320AIC310xEVM software can now be launched. The user should see an initial screen that looks similar to [Figure 2](#).

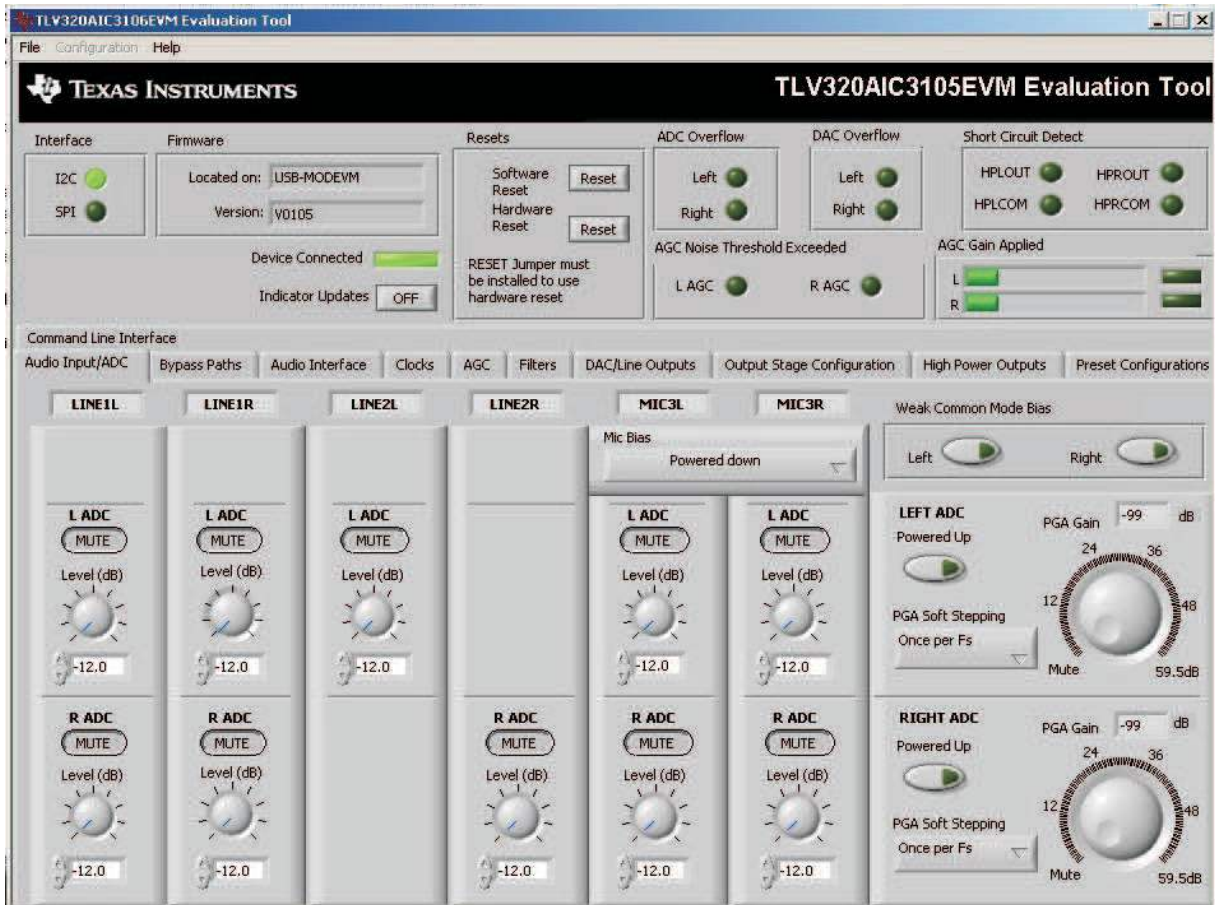

Figure 2. Default Software Screen

4 TLV320AIC3105EVM Software

The following section discusses the details and operation of the EVM software.

NOTE: For configuration of the codec, the TLV320AIC3105 block diagram located in the [TLV320AIC3105](#) data sheet is a good reference to help determine the signal routing.

4.1 Device Selection for Operation With AIC3105EVM

The software that is installed provides operation for several devices. An initial window should appear that looks like [Figure 3](#). For operation with the TLV320AIC3105EVM, the user should select *AIC3105* from the pulldown menu and click **Accept**. The software will take a few seconds to configure the software for operation before proceeding. A progress bar should appear and show the status of the configuration.



Figure 3. Device Selection Window

4.2 Front Page Indicators and Functions

Figure 2 illustrates the main screen of the EVM software. The indicators and buttons located above the tabbed section of the front page are visible regardless of which tab is currently being selected.

At the top left of the screen is an **Interface** indicator. This indicator shows the I²C interface is selected for controlling the TLV320AIC3105.

To the right of the interface indicator is a group box called **Firmware**. This box indicates where the firmware being used is operating from—in this release, the firmware is on the USB-MODEVM, so the user should see *USB-MODEVM* in the box labeled **Located On:**. The version of the firmware appears in the **Version** box below this.

To the right, the next group box contains controls for resetting the TLV320AIC3105. A software reset can be done by writing to a register in the TLV320AIC3105, and this is accomplished by pushing the button labeled **Software Reset**. The TLV320AIC3105 also may be reset by toggling a pin on the TLV320AIC3105, which is done by pushing the **Hardware Reset** button.

CAUTION

In order to perform a hardware reset, the RESET jumper (JMP19) must be installed and SW2-7 on the USB-MODEVM must be turned OFF. Failure to do either of these steps results in not generating a hardware reset or causing unstable operation of the EVM, which may require cycling power to the USB-MODEVM.

Below the **Firmware** box, the **Device Connected** LED should be green when the EVM is connected. If the indicator is red, the EVM is not properly connected to the PC. Disconnect the EVM and verify that the drivers were correctly installed, then reconnect and try restarting the software.

On the upper right portion of the screen, several indicators are located which provide the status of various portions of the TLV320AIC3105. These indicators are activated by pressing the **Indicator Updates** button below the **Device Connected** LED. These indicators, as well as the other indicators on this panel, are updated only when the software's front panel is inactive, once every 20ms.

The **ADC Overflow** and **DAC Overflow** indicators light when the overflow flags are set in the TLV320AIC3105. Below these indicators are the **AGC Noise Threshold Exceeded** indicators that show when the AGC noise threshold is exceeded. To the far right of the screen, the **Short Circuit Detect** indicators show when a short-circuit condition is detected, if this feature has been enabled. Below the short-circuit indicators, the **AGC Gain Applied** indicators use a bar graph to show the amount of gain which has been applied by the AGC, and indicators that light when the AGC is saturated.

4.3 Preset Configuration Tab

The Default Configuration tab [Figure 4](#) provides several different preset configurations of the codec. The **Preset Configurations** buttons allow the user to choose from the provided defaults. When the selection is made, the **Preset Configuration Description** are shows a summary of the codec setup associated with the choice made. If the choice is acceptable, the **Load** button can be pressed and the preset configuration will be loaded into the codec. The user can change to the **Command Line Interface** tab (see [Figure 27](#)) to view the actual settings that were programmed into the codec.

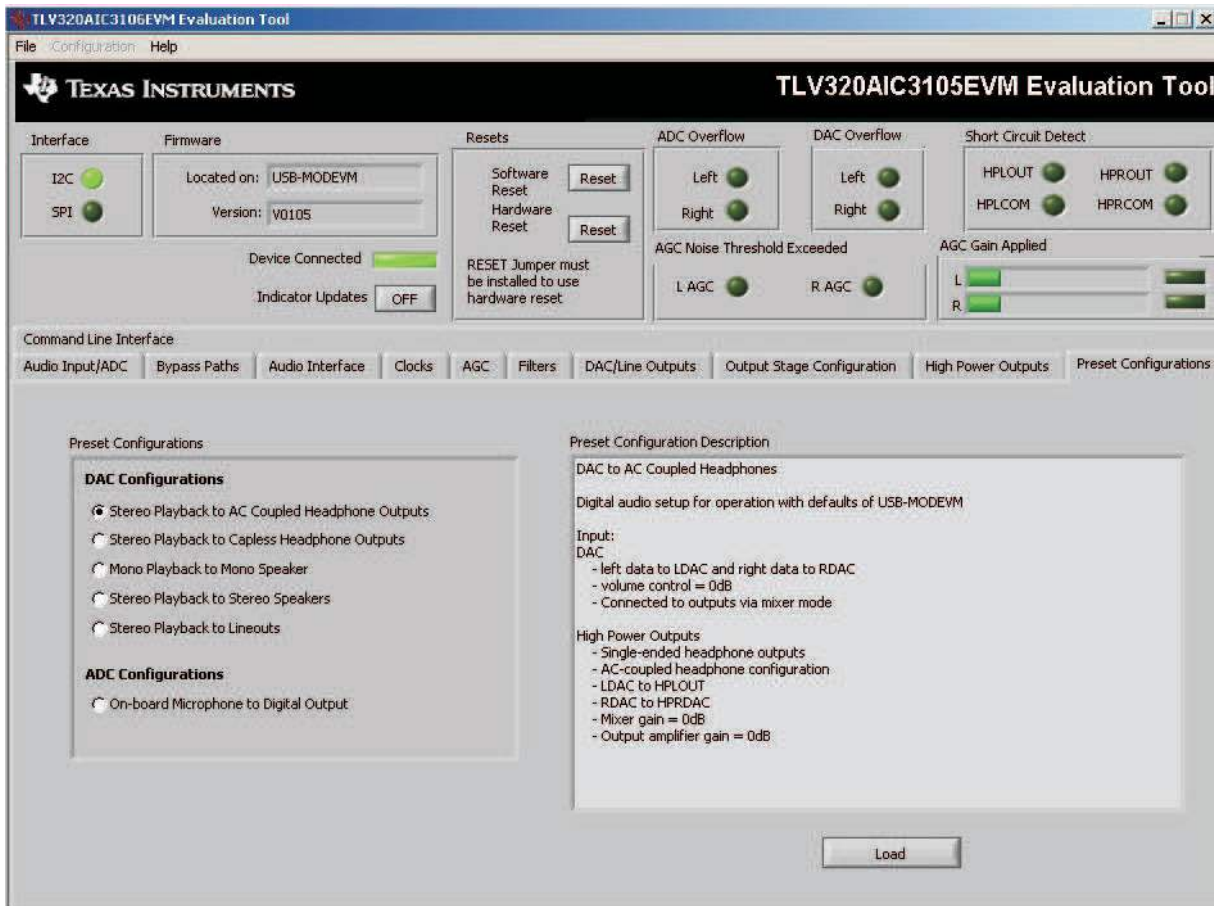

Figure 4. Preset Configuration Tab

4.4 Audio Input/ADC Tab

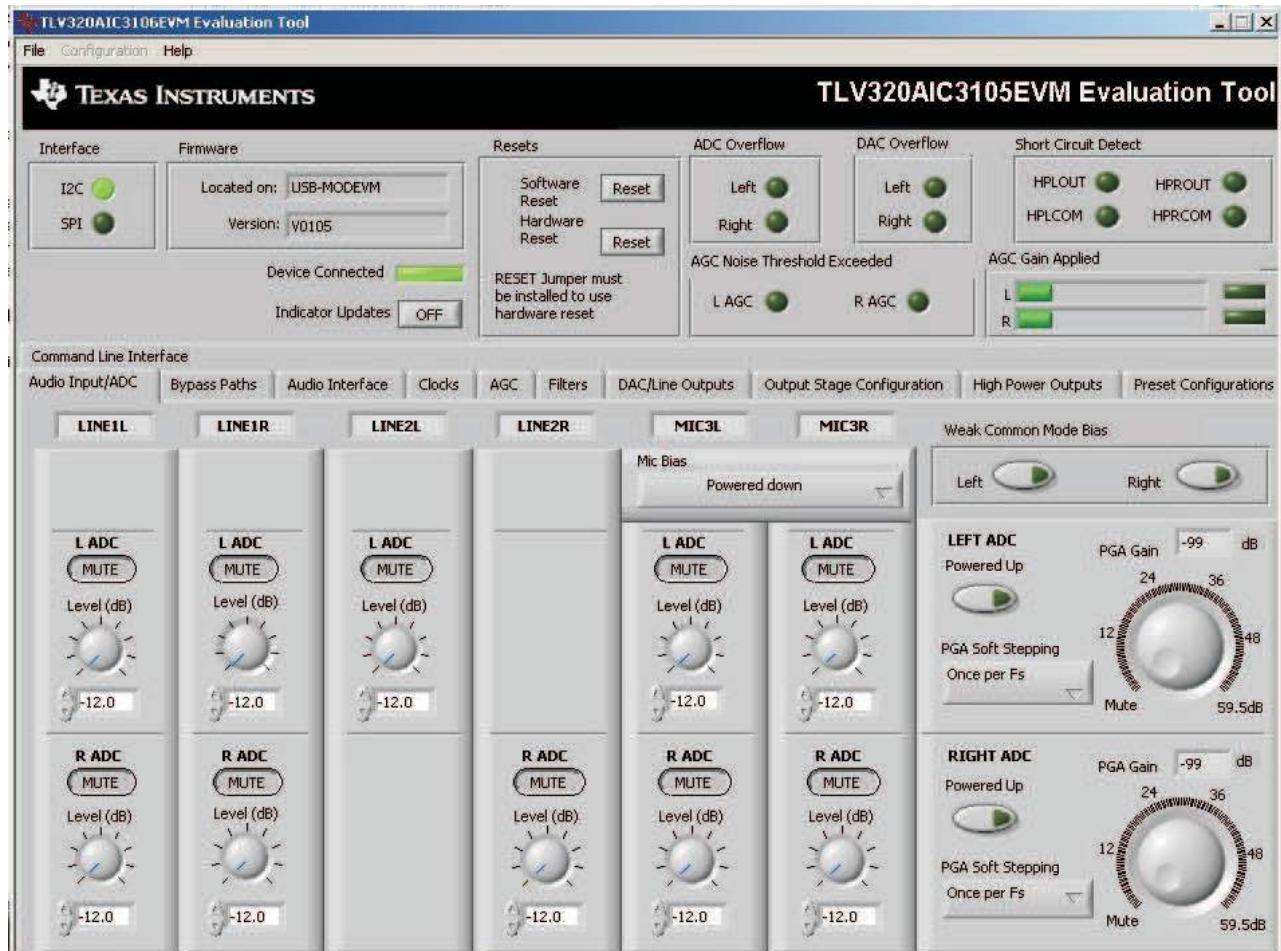

Figure 5. Audio Input/ADC Tab

The **Audio Input/ADC** tab allows control of the analog input mixer and the ADC. The controls are displayed to look similar to an audio mixing console (see Figure 5). Each analog input channel has a vertical strip that corresponds to that channel. By default, all inputs are muted when the TLV320AIC3105 is powered up.

To route an analog input to the ADC:

1. Select the **Input Mode** button to correctly show if the input signal is single-ended (*SE*) or fully-differential (*Diff*). Inputs that are single-ended should be made to the positive signal terminal.
2. Click on the button of the analog input channel that corresponds to the correct ADC. The caption of the button should change to *Active*. Note that the user can connect some channels to both ADCs, while others will only connect to one ADC.
3. Adjust the **Level** control to the desired attenuation for the connected channel. This level adjustment can be done independently for each connection.

The TLV320AIC3105 offers a programmable microphone bias that can either be powered down or set to 2.0V, 2.5V, or the power supply voltage of the ADC (AVDD_ADC). Control of the microphone bias (mic bias) voltage is accomplished by using the **Mic Bias** pulldown menu button above the last two channel strips. To use the onboard microphone, JMP2 and JMP3 must be installed and nothing should be plugged into J6. In order for the mic bias settings in the software to take effect, JMP1 should be set to connect positions 2 and 3, so that mic bias is controlled by the TLV320AIC3105.

In the upper right portion of this tab are controls for **Weak Common Mode Bias**. Enabling these controls will result in unselected inputs to the ADC channels to be weakly biased to the ADC common mode voltage.

Below these controls are the controls for the ADC PGA, including the master volume controls for the ADC inputs. Each channel of the ADC can be powered up or down as needed using the **Powered Up** buttons. PGA soft-stepping for each channel is selected using the pulldown menu control. The two large knobs set the actual **ADC PGA Gain** and allow adjustment of the PGA gains from 0 dB to 59.5 dB in 0.5-dB steps (excluding Mute). At the extreme counterclockwise rotation, the channel is muted. Rotating the knob clockwise increases the PGA gain, which is displayed in the box directly above the volume control.

4.5 Bypass Paths Tab

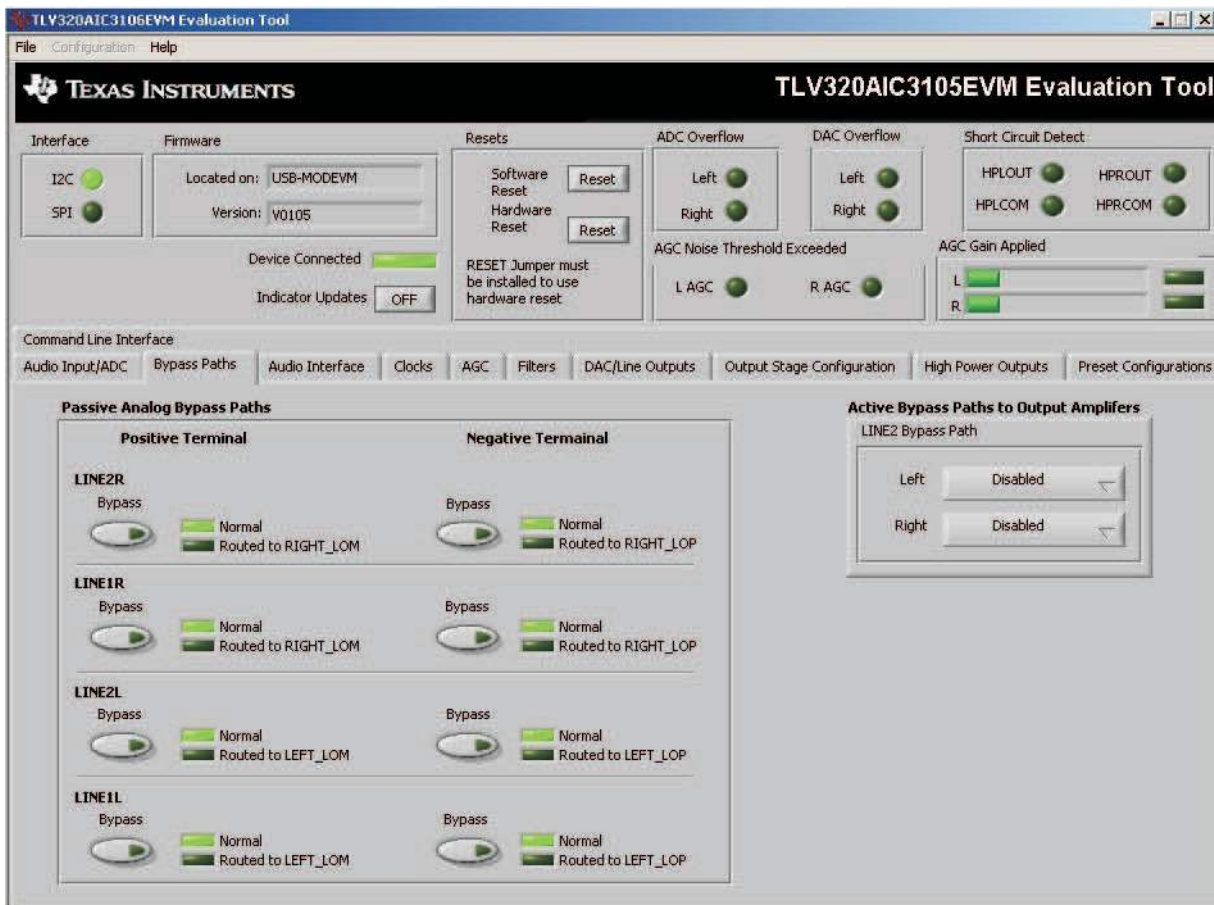

Figure 6. Bypass Paths Tab

The **Bypass Paths** tab shows the active and passive bypass paths available for control.

The passive analog bypass paths allow the inputs to be routed straight through the device to the outputs without turning on any of the internal circuitry. This provides a signal path through the device with minimal power consumption.

The active bypass paths allow the inputs to bypass the ADC and DAC functional blocks and be routed to the analog output mixers to be summed into the output amplifiers.

4.6 Audio Interface Tab

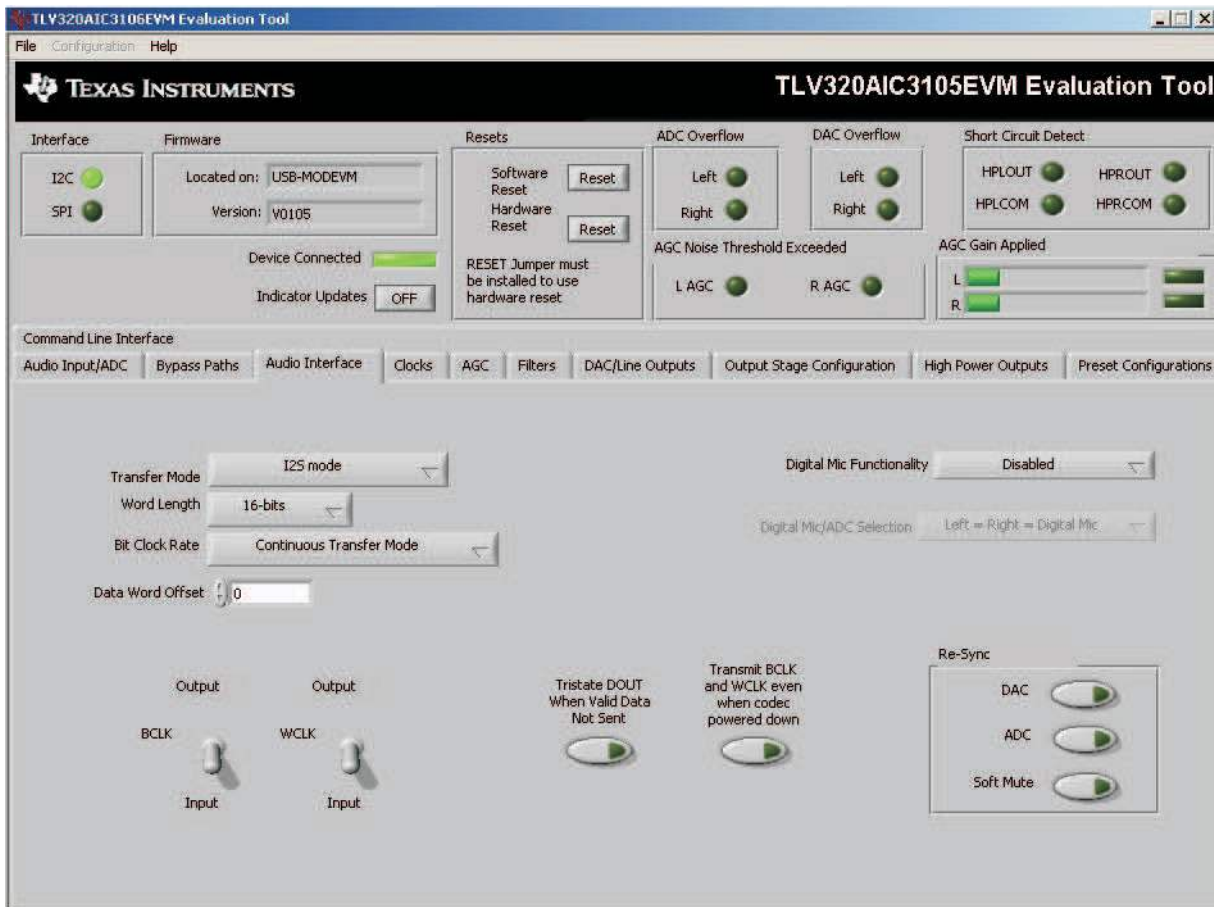

Figure 7. Audio Interface Tab

The Audio Interface tab (Figure 7) allows configuration of the audio digital data interface to the TLV320AIC3105.

The interface mode may be selected using the **Transfer Mode** control—selecting either I²S mode, DSP mode, or Right- or Left-Justified modes. Word length can be selected using the **Word Length** control, and the bit clock rate can also be selected using the **Bit Clock** rate control. The **Data Word Offset**, used in TDM mode (see the [AIC3105](#) data sheet) can also be selected on this tab.

Along the bottom of this tab are controls for choosing the **BCLK** and **WCLK** as being either inputs or outputs. With the codec configured in *Slave* mode, both the BCLK and WCLK are set to inputs. If the codec is in *Master* mode, then BCLK and WCLK are configured as outputs. Additionally, two buttons provide the options for placing the DOUT line in a 3-state mode when there is not valid data and transmitting BCLK and WCLK when the codec is powered down.

Re-sync of the audio bus is enabled using the controls in the lower right corner of this screen. Re-sync is done if the group delay changes by more than $\pm FS/4$ for the ADC or DAC sample rates (see the [TLV320AIC3105](#) data sheet). The channels can be soft muted when doing the re-sync if the **Soft Mute** button is enabled.

The default mode for the EVM is configured as 44.1 kHz, 16-bit, I² words, and the codec is a slave (BCLK and WCLK are supplied to the codec externally). For use with the PC software and the USB-MODEVM, the default settings should be used; no change to the software are required.

4.7 Clocks Tab

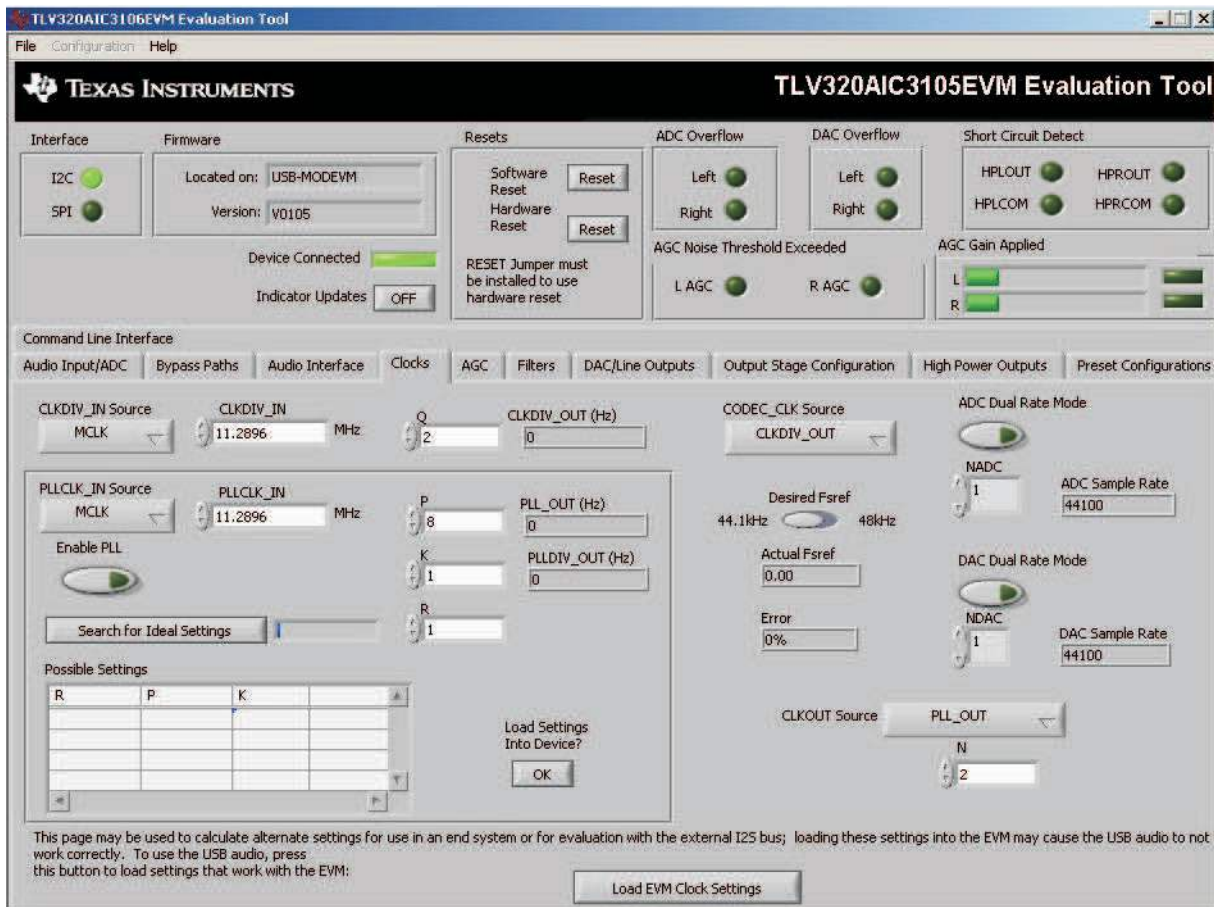

Figure 8. Clocks Tab

The TLV320AIC3105 provides a phase-locked loop (PLL) that allows flexibility in the clock generation for the ADC and DAC sample rates. The Clocks tab contains the controls that can be used to configure the TLV320AIC3105 for operation with a wide range of master clocks. See the Audio Clock Generation Processing figure in the [TLV320AIC3105](#) data sheet for further details of selecting the correct clock settings.

For use with the PC software and the USB-MODEVM, the clock settings must be set a certain way. If the settings are changed from the default settings which allow operation from the USB-MODEVM clock reference, the EVM settings can be restored automatically by pushing the **Load EVM Clock Settings** button at the bottom of this tab. Note that changing any of the clock settings from the values loaded when this button is pushed may result in the EVM not working properly with the PC software or USB interface. If an external audio bus is used (audio not driven over the USB bus), then settings may be changed to any valid combination. See [Figure 8](#).

4.7.1 Configuring the Codec Clocks and Fsref Calculation

The codec clock source is chosen by the **CODEC_CLK Source** control. When this control is set to *CLKDIV_OUT*, the PLL is not used; when set to *PLLCLK_OUT*, the PLL is used to generate the clocks.

NOTE: Per the [TLV320AIC3105](#) data sheet, the codec should be configured to allow the value of Fsref to fall between the values of 39 kHz to 53 kHz.

4.7.1.1 Use Without PLL

Setting up the TLV320AIC3105 for clocking without using the PLL permits the lowest power consumption by the codec. The **CLKDIV_IN** source can be selected as either *MCLK* or *BCLK*; the default is *MCLK*. The **CLKDIV_IN** frequency is then entered into the **CLKDIV_IN** box, in megahertz (MHz). The default value shown, 11.2896 MHz, is the frequency used on the USB-MODEVM board. This value is then divided by the value of **Q**, which can be set from 2 to 17; the resulting **CLKDIV_OUT** frequency is shown in the indicator next to the **Q** control. The result frequency is shown as the *Actual Fsref*.

4.7.1.2 Use With PLL

When **PLLDIV_OUT** is selected as the codec clock source, the PLL is used. The PLL clock source is chosen using the **PLLCLK_IN** control, and may be set to either *MCLK* or *BCLK*. The **PLLCLK_IN** frequency is then entered into the **PLLCLK_IN Source** box.

The **PLL_OUT** and **PLLDIV_OUT** indicators show the resulting PLL output frequencies with the values set for the **P**, **K**, and **R** parameters of the PLL. See the [TLV320AIC3105](#) data sheet for an explanation of these parameters. The parameters can be set by clicking on the up/down arrows of the **P**, **K**, and **R** combo boxes, or they can be typed into these boxes.

The values can also be calculated by the PC software. To use the PC software to find the ideal values of **P**, **K**, and **R** for a given PLL input frequency and desired **Fsref**:

1. Verify the correct reference frequency is entered into the **PLLCLK_IN Source** box in megahertz (MHz)
2. The desired **Fsref** should be set using the **Fsref** switch.
3. Push the **Search for Ideal Settings** button. The software will start searching for ideal combinations of **P**, **K**, and **R** which achieve the desired **Fsref**. The possible settings for these parameters are displayed in the spreadsheet-like table labeled *Possible Settings*.
4. Click on a row in this table to select the **P**, **K**, and **R** values located in that row. Notice that when this is done, the software updates the **P**, **K**, **R**, **PLL_OUT** and **PLLDIV_OUT** readings, as well as the *Actual Fsref* and *Error* displays. The values show the calculations based on the values that were selected. This process does not actually load the values into the TLV320AIC3105, however; it only updates the displays in the software. If more than one row exists, the user can choose the other rows to see which of the possible settings comes closest to the ideal settings.

When a suitable combination of **P**, **K**, and **R** have been chosen, pressing the **Load Settings into Device?** button will download these values into the appropriate registers on the TLV320AIC3105.

4.7.1.3 Setting ADC and DAC Sampling Rates

The **Fsref** frequency that determines either enabling or bypassing the PLL (see [Section 4.7.1.1](#) or [Section 4.7.1.2](#)) is used to determine the actual ADC and DAC sampling rates. Using the **NADC** and **NDAC** factors the sampling rates are derived from the **Fsref**. If dual rate mode is desired, this option can be enabled for either the ADC or DAC by pressing the corresponding **Dual Rate Mode** button. The ADC and DAC sampling rates are shown in the box to the right of each control.

4.8 AGC Tab

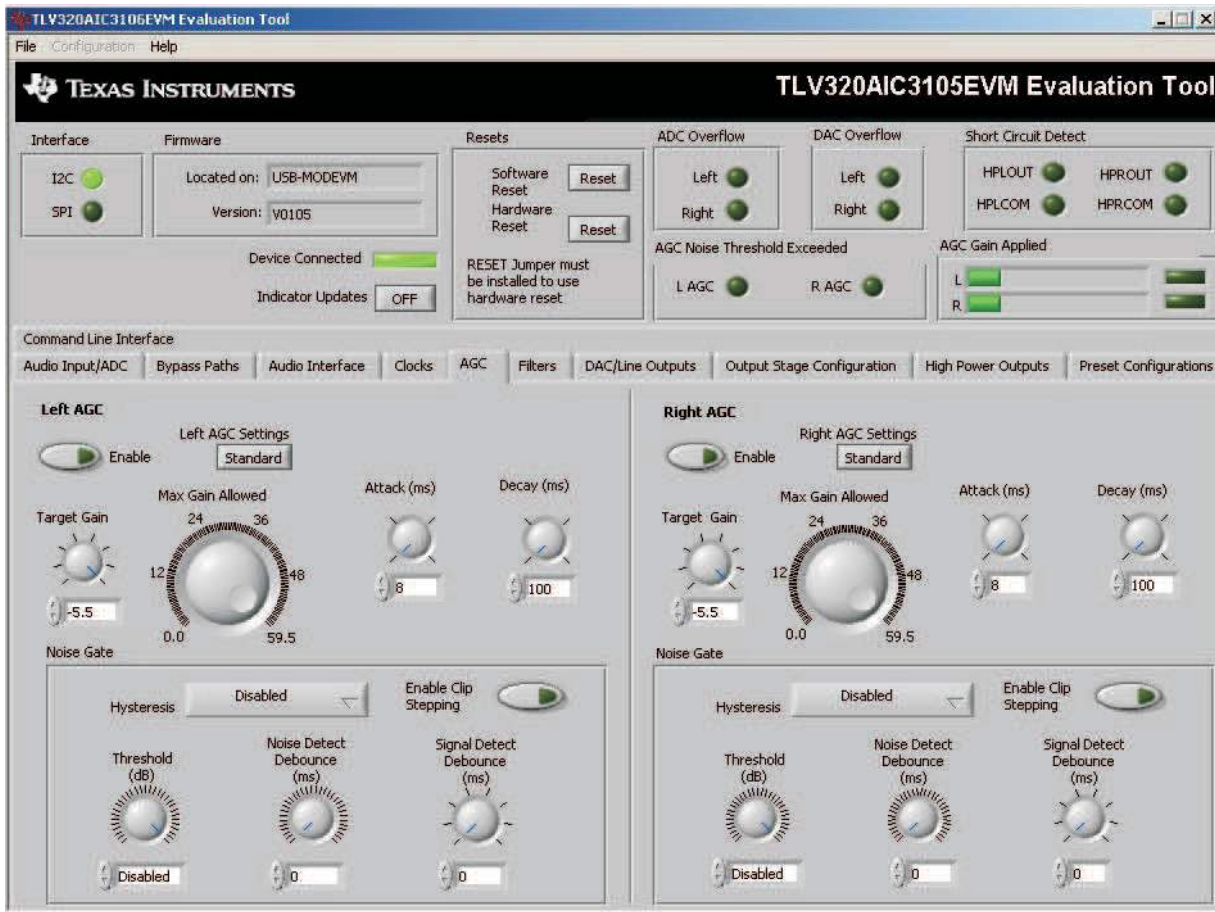

Figure 9. AGC Tab

The AGC tab (see [Figure 9](#)) consists of two identical sets of controls, one for the left channel and the other for the right channel. The AGC function is described in the [TLV320AIC3105](#) data sheet.

The AGC can be enabled for each channel using the **Enable AGC** button. **Target** gain, **Attack** time in milliseconds, **Decay** time in milliseconds, and the **Maximum PGA Gain Allowed** can all be set, respectively, using the four corresponding knobs in each channel.

The TLV320AIC3105 allows for the Attack and Decay times of the AGC to be setup in two different modes, standard and advanced. The **Left/Right AGC Settings** button determines the mode selection. The *Standard* mode provides several preset times that can be selected by adjustments made to the **Attack** and **Decay** knobs. If finer control over the times is required, then the *Advanced* mode is selected to change to the settings. When the *Advanced* mode is enabled, two tabs should appear that allow separate, advanced control of the Attack and Delay times of the AGC (see [Figure 10](#) and [Figure 11](#)). These options allow selection of the base time as well as a multiplier to achieve the actual times shown in the corresponding text box. The **Use advanced settings?** button should be enabled to program the registers with the correct values selected via the pulldown options for base time and multiplier.

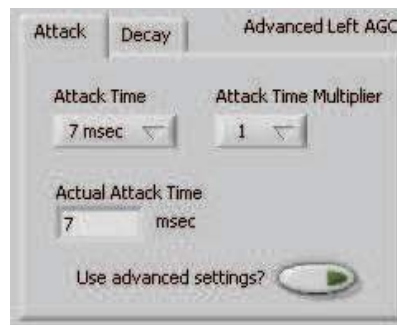

Figure 10. Left AGC Settings



Figure 11. Advanced

Noise gate functions, such as **Hysteresis**, **Enable Clip stepping**, **Threshold (dB)**, **Signal Detect Debounce (ms)**, and **Noise Detect Debounce (ms)** are set using the corresponding controls in the **Noise Gate** group box for each channel.

4.9 Filters Tab

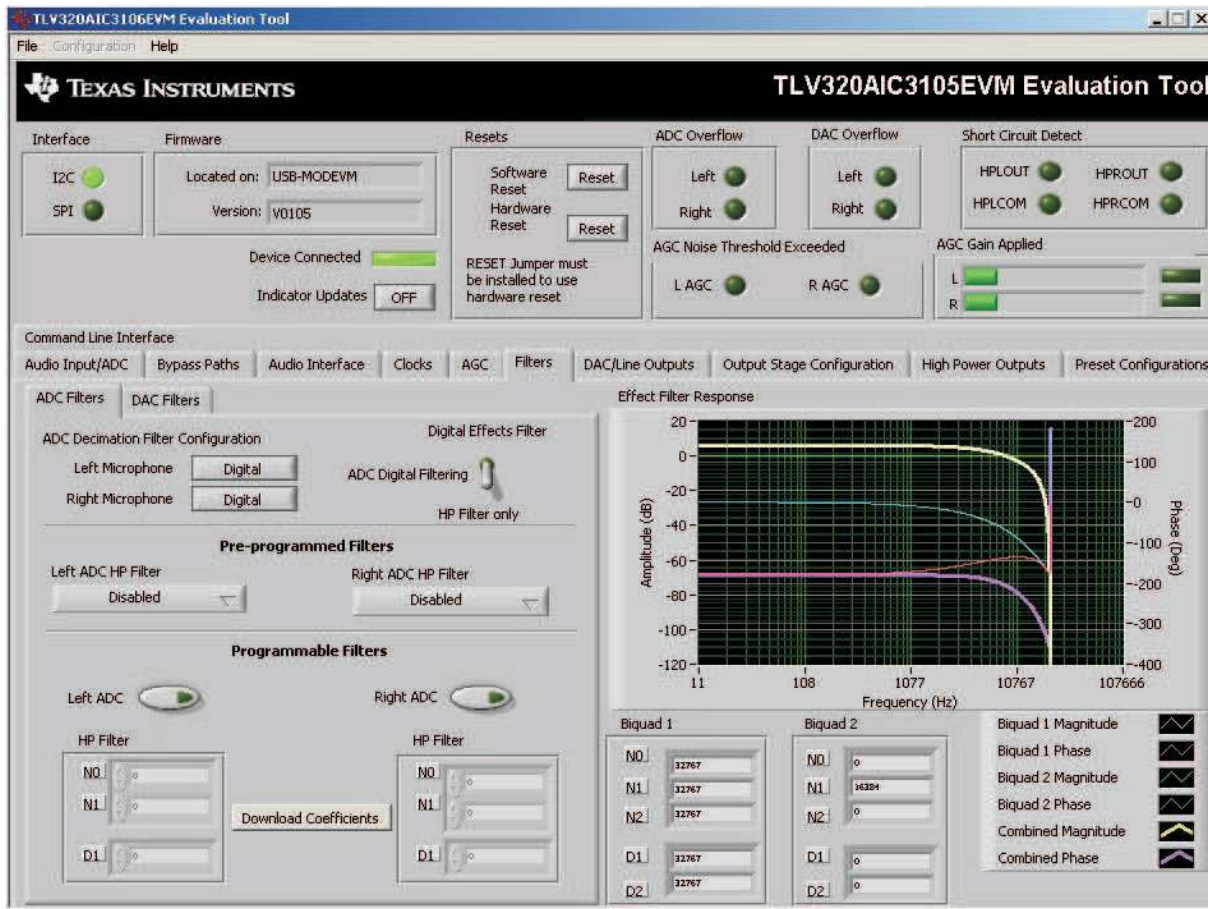

Figure 12. Filters Tab

The TLV320AIC3105 has an advanced feature set for applying digital filtering to audio signals. This tab controls all of the filter features of the TLV320AIC3105. In order to use this tab and have plotting of filter responses correct, the DAC sample rate must be set correctly. Therefore, the clocks must be set up correctly in the software following the discussion in [Section 4.7](#). See [Figure 12](#).

The AIC3105 digital filtering is available to both the ADC and DAC. The ADC has optional high-pass filtering and allows the digital output from the ADC through digital effects filtering before exiting the codec through the PCM interface. Likewise, the digital audio data can be routed through the digital effects filtering before passing through the optional de-emphasis filter before the DAC. The digital effects filtering can only be connected to either the ADC or DAC, not both at the same time.

The [Figure 12](#) is divided into several areas. The left side of the tab, is used to select between the DAC or ADC filters and assist in the selection and calculating the desired filter coefficients. The right hand side of the tab shows a frequency response plot of the digital effects filter selected and the coefficients that are programmed into the device. The plots show the magnitude and phase response of each biquad section, plus the combined responses of the two biquad filters. Note that the plot shows only the responses of the effect filters, not the combined response of those filter along with the de-emphasis and ADC high-pass filters.

4.9.1 ADC Filters

4.9.1.1 High-Pass Filter

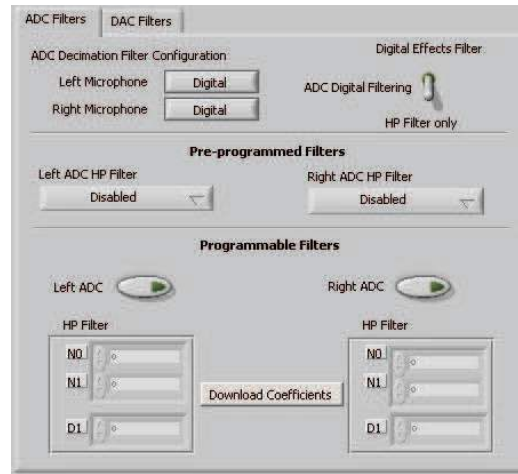

Figure 13. ADC High-Pass Filters

The TLV320AIC3105 ADC provides the option of enabling a high-pass filter, which helps to reduce the effects of DC offsets in the system. The [Figure 13](#) tab shows the options for programming various filter associated with the ADC. The high-pass filter has two modes: standard and programmable.

The standard high-pass filter option ([Figure 14](#)) allows for the selection of the high-pass filter frequency from several preset options that can be chosen with the **Left ADC HP Filter** and **Right ADC HP Filter** controls. The four options for this setting are disabled, or three different corner frequencies which are based on the ADC sample rate.

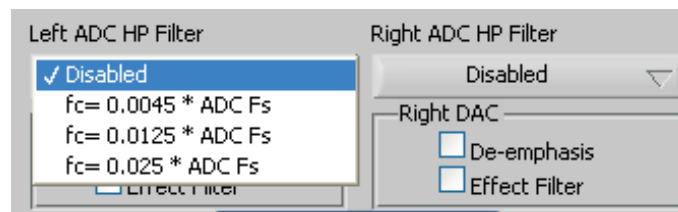

Figure 14. ADC High-Pass Filter Settings

For custom filter requirements, the programmable function allows custom coefficients to achieve a different filter than provided by the preset filters. The controls for the programmable high-pass filter are located under the **Programmable Filters** heading. The process should following the following steps:

1. Enter The filter coefficients can be entered in the **HP Filter** controls near the bottom of the tab.
2. Press the **Download Coefficients** button to download the coefficients to the codec registers.
3. Enable the Programmable High-Pass Filters by selecting the **Left ADC** and **Right ADC** buttons.

The programmable high-pass filter should now be correctly programmed and enabled. The ADC can now be enabled with the high-pass filter.

4.9.1.2 Digital Effects Filter - ADC

The ADC digital outputs stream can be routed through the digital effects filter in the codec to allow custom audio performance. The digital effects filter cannot operate on both the ADC or DAC at the same time. The digital effects filter operation is discussed in [Section 4.9.3](#)

4.9.2 DAC Filters

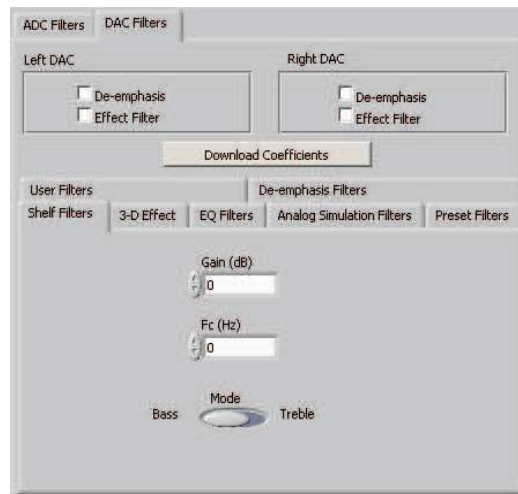

Figure 15. DAC Filters

4.9.2.1 De-emphasis Filters

The de-emphasis filters used in the TLV320AIC3105 can be programmed as described in the [TLV320AIC3105](#) data sheet, using this tab (Figure 16). Enter the coefficients for the de-emphasis filter response desired. While on this tab, the de-emphasis response is shown on the *Effect Filter Response* graph; however, note that this response is not included in graphs of other effect responses when on the other filter design tabs.

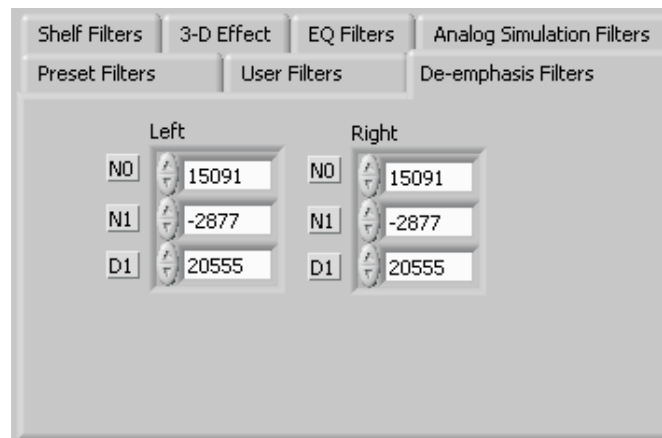

Figure 16. De-emphasis Filters

4.9.2.2 DAC Digital Effects Filter

The digital audio input stream can be routed through the digital effects filter in the codec before routing to the DAC to allow custom audio performance. The digital effects filter cannot operate on both the ADC or DAC at the same time. The digital effects filter operation is discussed in [Section 4.9.3](#)

4.9.3 Digital Effects Filters

The digital effect filters (the biquad filters) of the TLV320AIC3105 are selected using the check boxes shown in [Figure 17](#). The De-emphasis filters are described in the [TLV320AIC3105](#) data sheet, and their coefficients may be changed (see [Figure 15](#)).



Figure 17. Enabling Filters

When designing filters for use with TLV320AIC3105, the software allows for several different filter types to be used. These options are shown on a tab control in the lower left corner of the screen. When a filter type is selected, and suitable input parameters defined, the response will be shown in the *Effect Filter Response* graph. Regardless of the setting for enabling the Effect Filter, the filter coefficients are not loaded into the TLV320AIC3105 until the **Download Coefficients** button is pressed. To avoid noise during the update of coefficients, it is recommended that the user uncheck the **Effect Filter enable** check boxes before downloading coefficients. Once the desired coefficients are in the TLV320AIC3105, enable the Effect Filters by checking the boxes again.

4.9.3.1 Shelf Filters

A shelf filter is a simple filter that applies a gain (positive or negative) to frequencies above or below a certain corner frequency. As shown in [Figure 18](#), in *Bass* mode a shelf filter applies a gain to frequencies below the corner frequency; in *Treble* mode the gain is applied to frequencies above the corner frequency.

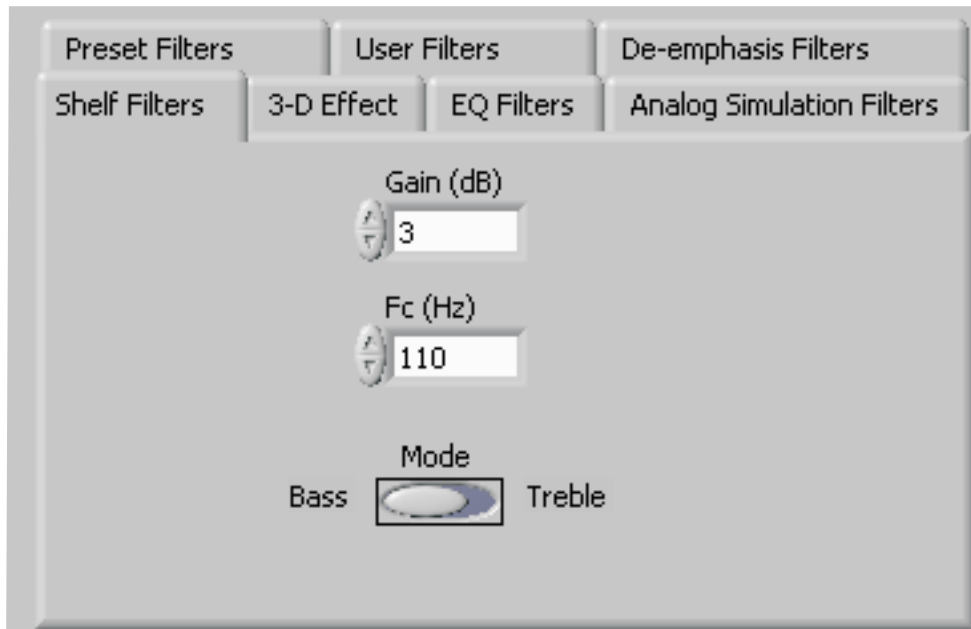

Figure 18. Shelf Filters

To use these filters, enter the gain desired and the corner frequency. Choose the mode to use (*Bass* or *Treble*); the response will be plotted on the *Effect Filter Response* graph.

4.9.3.2 EQ Filters

EQ, or parametric, filters can be designed on this tab (see [Figure 19](#)). Enter a gain, bandwidth, and a center frequency (Fc). Either bandpass (positive gain) or band-reject (negative gain) filters can be created

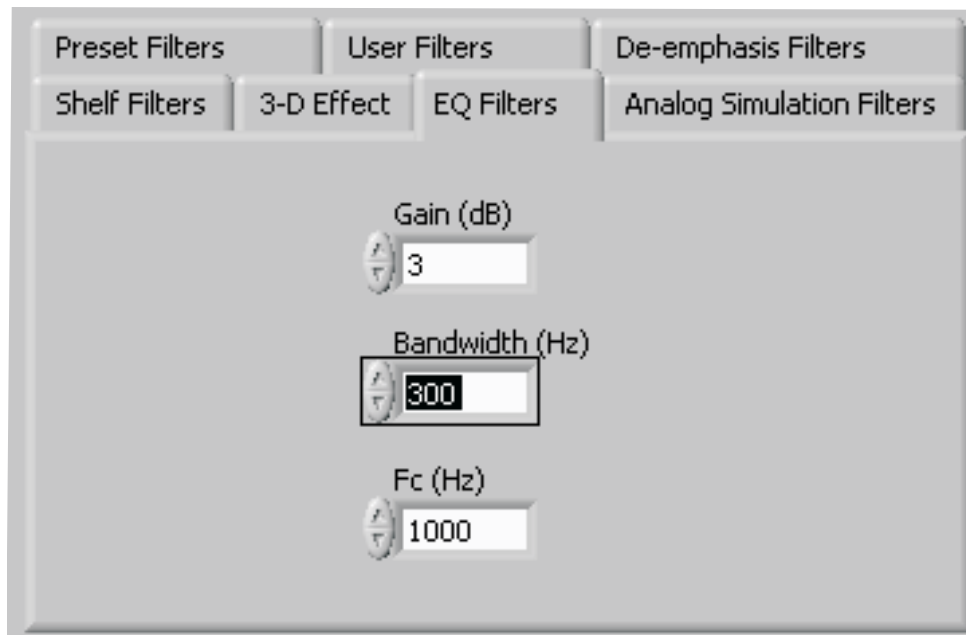

Figure 19. EQ Filters

4.9.3.3 Analog Simulation Filters

Biquads are good at simulating analog filter designs. For each biquad section on this tab, enter the desired analog filter type to simulate (Butterworth, Chebyshev, Inverse Chebyshev, Elliptic or Bessel). Parameter entry boxes appropriate to the filter type will be shown (ripple, for example, with Chebyshev filters, etc.). Enter the desired design parameters and the response is shown. (See [Figure 20](#).)

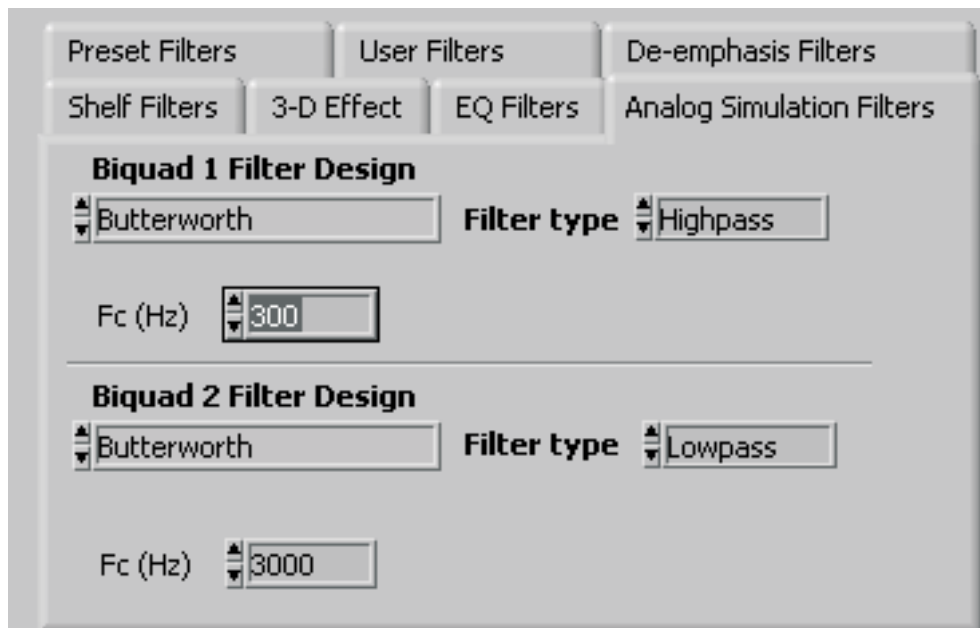

Figure 20. Analog Simulation Filters

4.9.3.4 Preset Filters

Many applications are designed to provide preset filters common for certain types of program material. This tab (see [Figure 21](#)) allows selection of one of four preset filter responses - Rock, Jazz, Classical, or Pop.

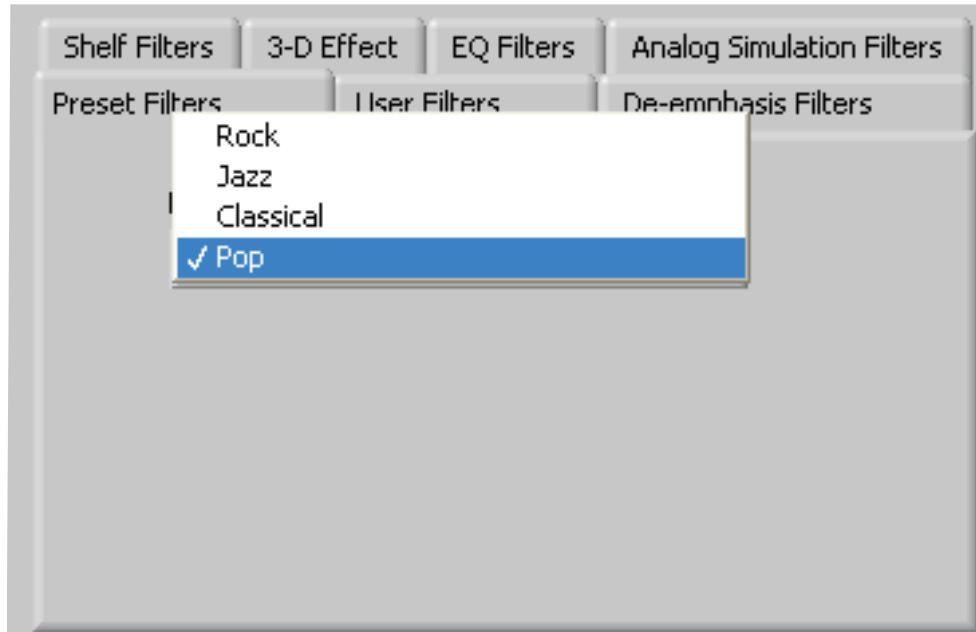

Figure 21. Preset Filters

4.9.3.5 User Filters

If filter coefficients are known, they can be entered directly on this tab (see [Figure 22](#)) for both biquads for both left and right channels. The filter response are **not** shown on the *Effect Filter Response* graph for user filters.

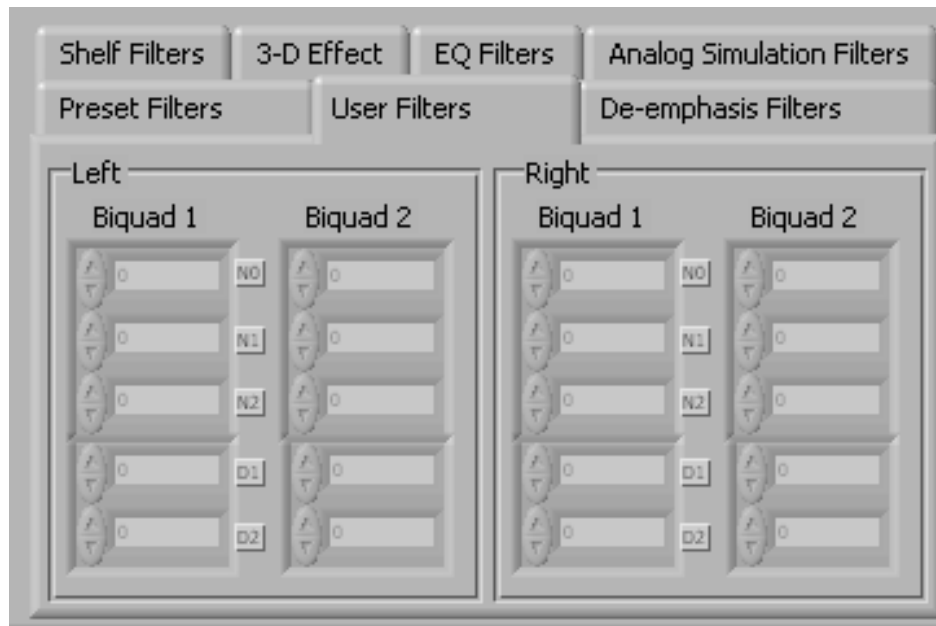

Figure 22. User Filters

4.9.3.6 3D Effect

The 3D effect is described in the [TLV320AIC3105](#) data sheet. It uses the two biquad sections differently than most other effect filter settings. To use this effect properly, ensure that the appropriate coefficients are already loaded into the two biquad sections. The User Filters tab can be used to load the coefficients. See [Figure 23](#).

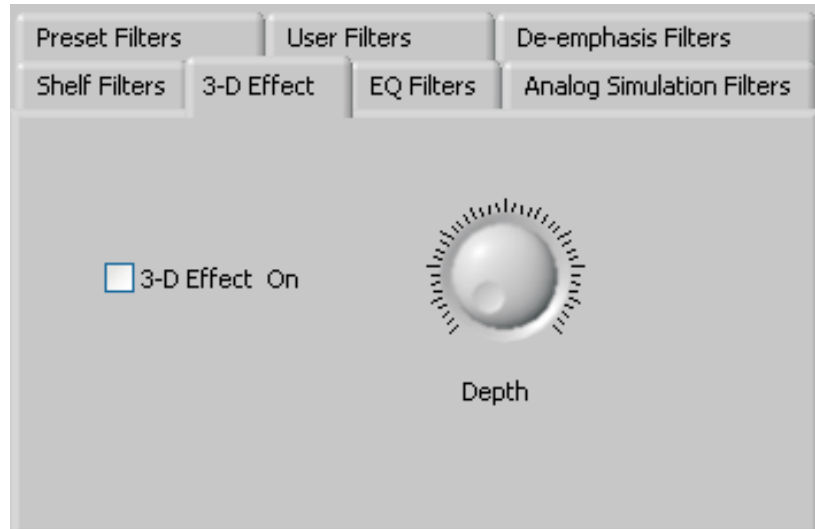

Figure 23. 3D Effect Settings

To enable the 3D effect, check the **3D Effect On** box. The **Depth** knob controls the value of the 3D Attenuation Coefficient.

4.10 Output Stage Configuration Tab

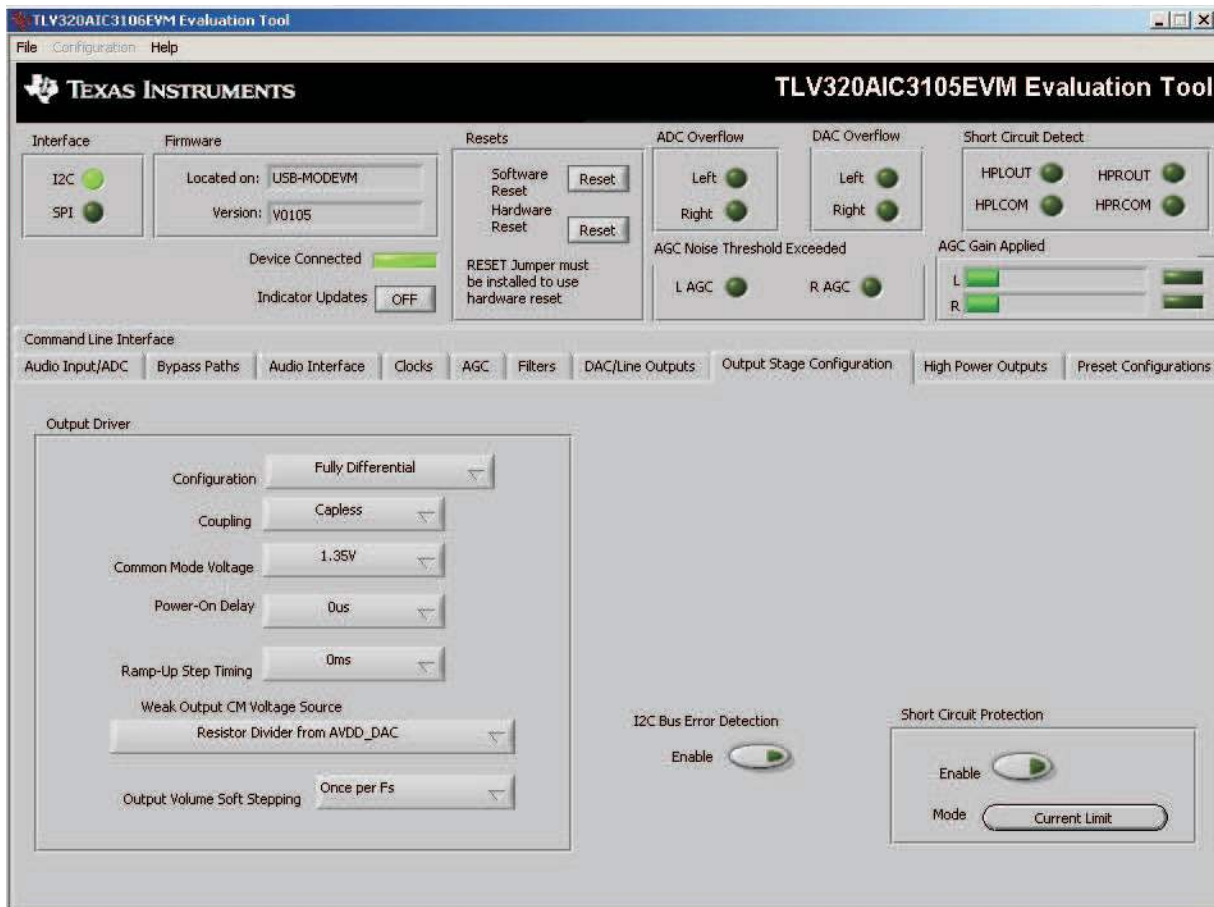

Figure 24. Output Stage Configuration Tab

The Output Stage Configuration tab (Figure 24) allows for setting various features of the output drivers.

The **Configuration** control can be set as either *Fully-Differential* or *Pseudo-Differential*. This control is used to determine if the output stage is being used to drive a fully differential output load or a output load where one of the outputs is referenced to a common-mode voltage (pseudo-differential).

The output **Coupling** control can be chosen as either *Capless* or *AC-coupled*. This setting should correspond to the setting of the hardware switch (SW1) on the TLV320AIC3105EVM.

The common mode voltage of the outputs may be set to 1.35 V, 1.5 V, 1.65 V, or 1.8 V using the **Common Mode Voltage** control.

The TLV320AIC3105 offers several options to help reduce the turn-on/off pop of the output amplifiers. The **Power-On Delay** of the output drivers can be set using the corresponding control from 0 μ s up to 4 s. **Ramp-Up Step Timing** can also be adjusted from 0 ms to 4 ms. The outputs can be set to soft-step their volume changes, using the **Output Volume Soft Stepping** control, and set to step once per F_s period, once per two F_s periods, or soft-stepping can be disabled altogether.

The high power outputs of the TLV320AIC3105 can be configured to go to a weak common-mode voltage when powered down. The source of this weak common-mode voltage can be set on this tab with the **Weak Output CM Voltage Source** drop-down. Choices for the source are either a resistor divider off the AVDD_DAC supply, or a bandgap reference. See the data sheet for more details on this option.

Output short-circuit protection can be enabled in the **Short Circuit Protection** group box. Short Circuit Protection can use a current-limit mode, where the drivers will limit current output if a short-circuit condition is detected, or in a mode where the drivers will power down when such a condition exists.

The **I²C Bus Error Detection** button allows the user to enable circuitry which sets a register bit (Register 107, D0) if an I²C bus error is detected.

4.11 DAC/Line Outputs Tab

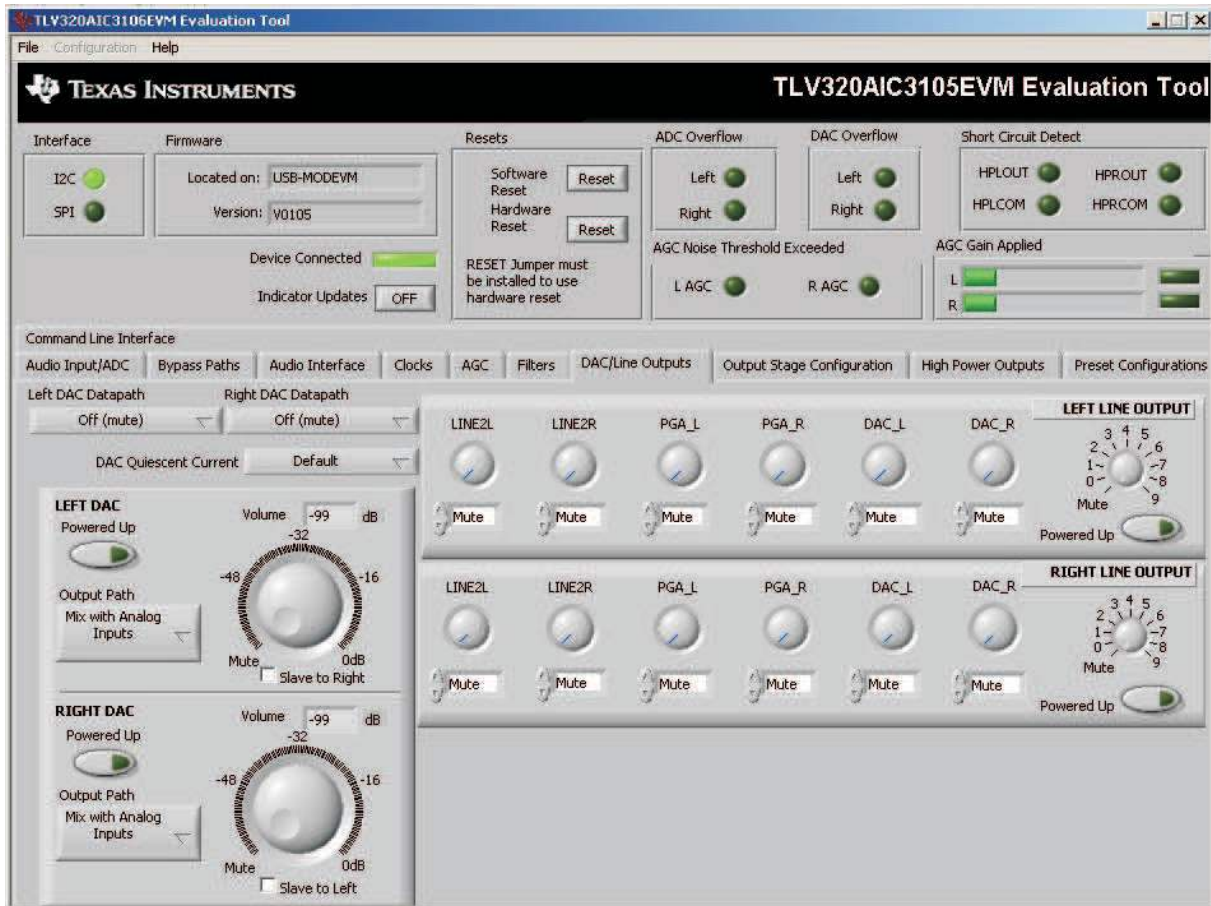

Figure 25. DAC/Line Outputs Tab

The DAC/Line Outputs tab controls the DAC power and volume, as well as routing of digital data to the DACs and the analog line output from the DACs. (See [Figure 25](#).)

4.11.1 DAC Controls

On the left side of this tab are controls for the left and right DACs.

In similar fashion as the ADC, the DAC controls are set up to allow powering of each DAC individually, and setting the output level. Each channel's level can be set independently using the corresponding **Volume** knob. Alternately, by checking the **Slave to Right** box, the left channel Volume can be made to track the right channel Volume knob setting; checking the **Slave to Left** box causes the right channel Volume knob to track the left Volume knob setting.

Data going to the DACs is selected using the drop-down boxes under the **Left** and **Right DAC Datapath**. Each DAC channel can be selected to be off, use left channel data, use right channel data, or use a mono mix of the left and right data.

Analog audio coming from the DACs is routed to outputs using the **Output Path** controls in each DAC control panel. The DAC output can be mixed with the analog inputs (LINE2L, LINE2R, PGA_L, PGA_R) and routed to the Line or High Power outputs using the mixer controls for these outputs on this tab (for the line outputs) or on the High Power Outputs tab (for the high power outputs). If the DAC is to be routed directly to either the Line or HP outputs, these can be selected as choices in the **Output Path** control. Note that if the Line or HP outputs are selected as the Output Path, the mixer controls on this tab and the High Power Output tabs have no effect.

4.11.2 Line Output Mixers

On the right side of this tab are horizontal panels where the analog output mixing functions for the line outputs are located.

Each line output master volume is controlled by the knob at the far right of these panels, below the line output labels. The output amplifier gain can be muted or set at a value between 0 and 9 dB in 1-dB steps. Power/Enabled status for the line output can also be controlled using the button below this master output knob (**Powered Up**).

If the DAC **Output Path** control is set to *Mix with Analog Inputs*, the six knobs in each panel can be used to set the individual level of signals routed and mixed to the line output. LINE2L, LINE2R, PGA_L, PGA_R, and DAC_L and DAC_R levels can each be set to create a custom mix of signals presented to that particular line output. **Note:** if the DAC **Output Path** control is set to anything other than *Mix with Analog Inputs*, these controls have no effect.

4.12 High Power Outputs Tab

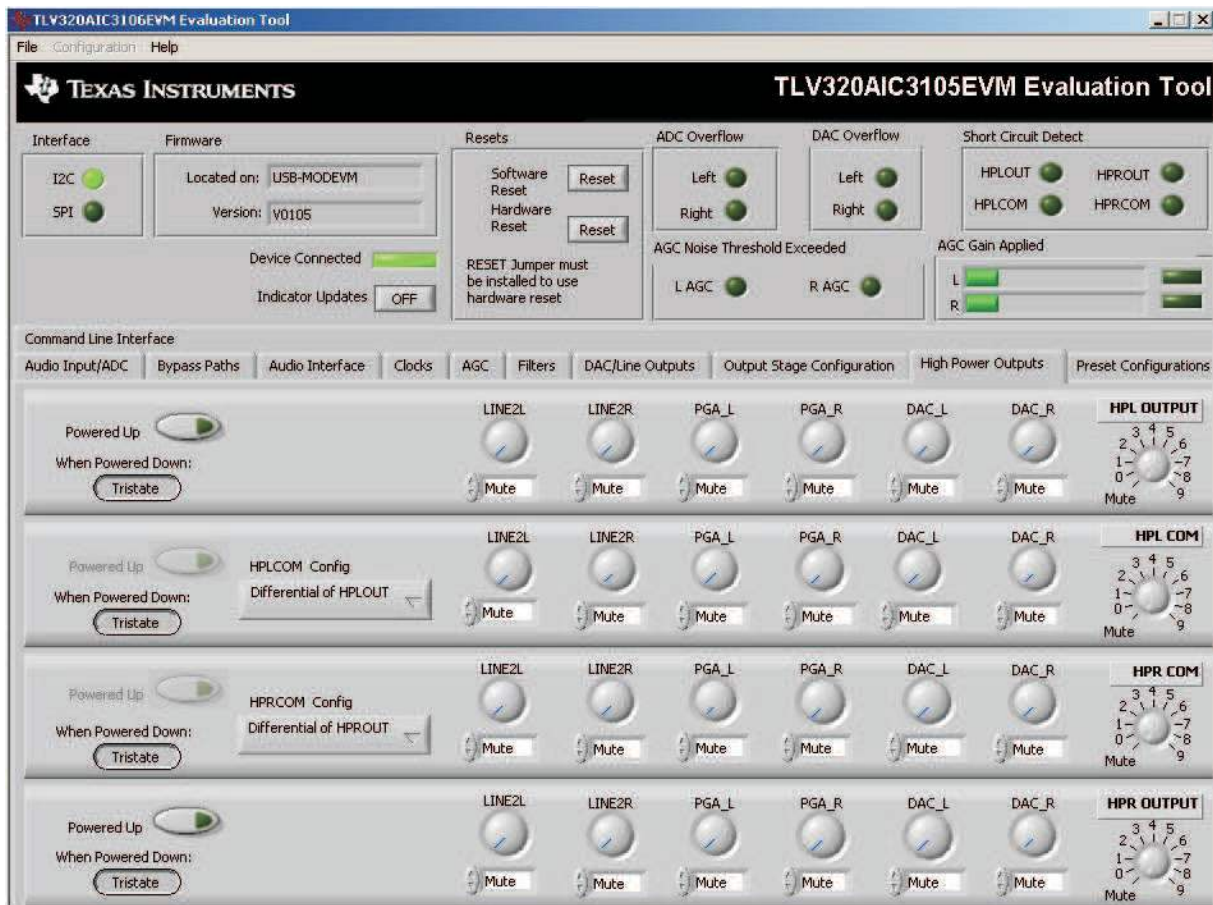

Figure 26. High Power Outputs Tab

This tab contains four horizontal groupings of controls, one for each of the high power outputs. Each output has a mixer to mix the LINE2L, LINE2R, PGA_L, PGA_R, DAC_L and DAC_R signals, assuming that the DACs are not routed directly to the high power outputs (see [Section 4.11](#)).

At the left of each output strip is a **Powered Up** button that controls whether the corresponding output is powered up or not. The **When powered down** button allows the outputs to be tri-stated or driven weakly to a the output common mode voltage.

The **HPxCOM** outputs (*HPLCOM* and *HPRCOM*) can be used as independent output channels or can be used as complementary signals to the HPLOUT and HPROUT outputs. In these complementary configurations, the **HPxCOM** outputs can be selected as *Differential of HPxOUT* signals to the corresponding outputs or may be set to be a common mode voltage (*Constant VCM Out*). When used in these configurations, the **Powered Up** button for the **HPxCOM** output is disabled, as the power mode for that output will track the power status of the HPL or HPR output that the COM output is tracking.

The **HPRCOM Config** selector allows a couple additional options compared to the **HPLCOM Config** selector. *Differential of HPLCOM* allows the HPRCOM to be the complementary signal of HPLCOM for driving a differential load between the **HPxCOM** outputs. The selector also allows *Ext. Feedback/HPLCOM constant VCM* as an option. This option is used when the high power outputs are configured for *Capless* output drive, where HPLCOM is configured as *Constant VCM Out*. The feedback option provides feedback to the output and lowers the output impedance of HPLCOM.

At the right side of the output strip is a master volume knob for that output, which allows the output amplifier gain to be muted or set from 0 to 9 dB in 1-dB steps.

4.13 Command Line Interface Tab

A simple scripting language controls the TAS1020 on the USB-MODEVM from the LabVIEW™ based PC software. The main program controls, described previously, do nothing more than write a script which is then handed off to an interpreter that sends the appropriate data to the correct USB endpoint. Because this system is script-based, provision is made in this tab for the user to view the scripting commands created as the controls are manipulated, as well as load and execute other scripts that have been written and saved (see Figure 27). This design allows the software to be used as a quick test tool or to help provide troubleshooting information in the rare event that the user encounters problem with this EVM.

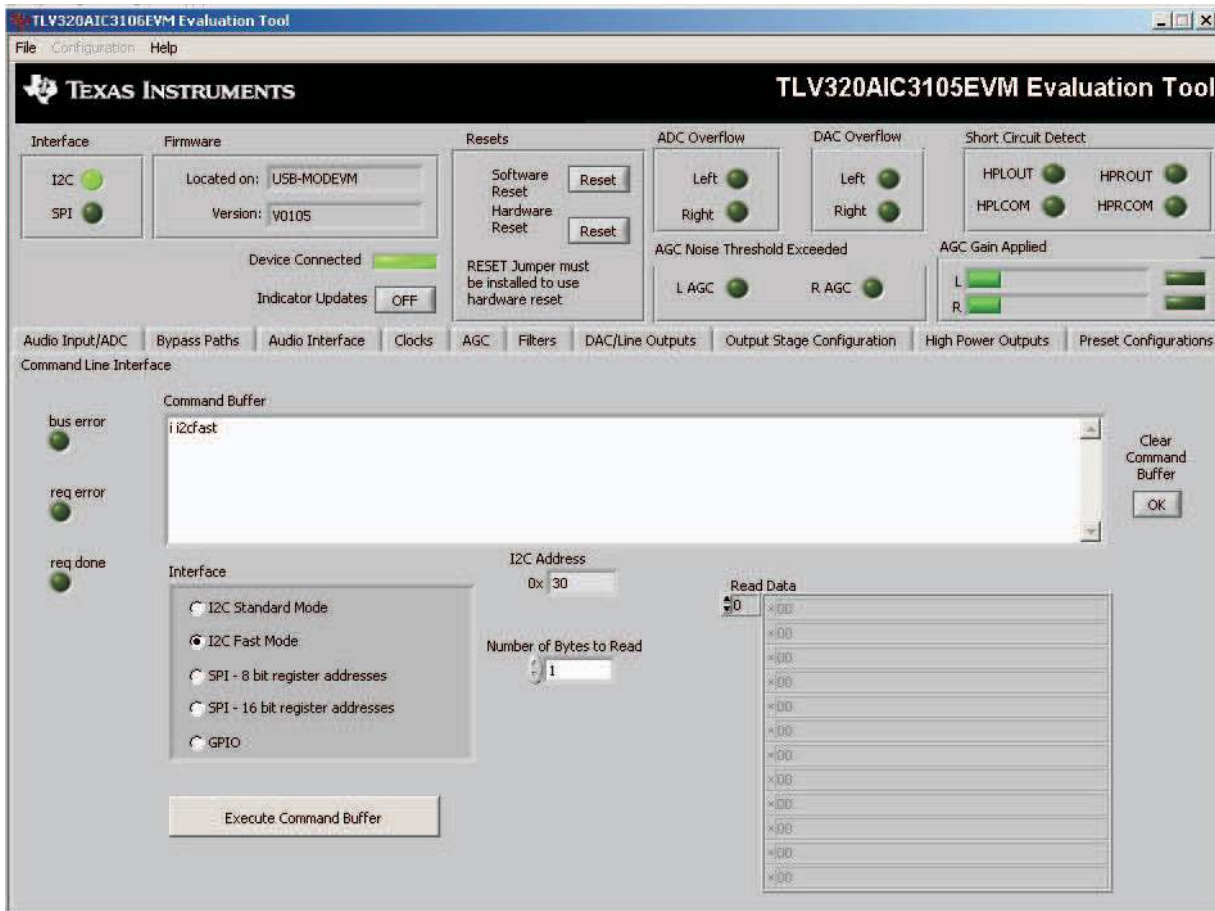

Figure 27. Command Line Interface Tab

A script is loaded into the command buffer, either by operating the controls on the other tabs or by loading a script file. When executed, the return packets of data which result from each command are displayed in the **Read Data** array control. When executing several commands, the Read Data control shows only the results of the last command. To see the results after every executed command, use the logging function described in the following paragraphs.

The File menu (Figure 28) provides some options for working with scripts. The first option, *Open Command File...*, loads a command file script into the command buffer. This script can then be executed by pressing the **Execute Command Buffer** button.

The second option is *Log Script and Results...*, which opens a file save dialog box. Choose a location for a log file to be written using this file save dialog. When the Execute Command Buffer button is pressed, the script runs and the script, along with resulting data read back during the script, is saved to the file specified. The log file is a standard text file that can be opened with any text editor, and looks much like the source script file, but with the additional information of the result of each script command executed.

The third menu item is a submenu of *Recently Opened Files*. This is simply a list of script files that have previously been opened, allowing fast access to commonly-used script files. The final menu item is *Exit*, which terminates the TLV320AIC3105EVM software.

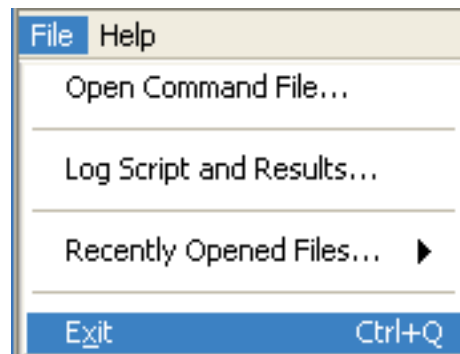

Figure 28. File Menu

Under the Help menu is an *About...* menu item which displays information about the TLV320AIC3105EVM software.

The actual USB protocol used as well as instructions on writing scripts are detailed in the following subsections. While it is unnecessary to understand or use either the protocol or the scripts directly, understanding them may be helpful to some users.

Appendix A EVM Connector Descriptions

This appendix contains the connection details for each of the main header connectors on the EVM.

A.1 Analog Interface Connectors

A.1.1 Analog Dual Row Header Details (J13 and J14)

For maximum flexibility, the TLV320AIC3105EVM is designed for easy interfacing to multiple analog sources. Samtec part numbers SSW-110-22-F-D-VS-K and TSM-110-01-T-DV-P provide a convenient 10-pin, dual-row header/socket combination at J13 and J14. These headers/sockets provide access to the analog input and output pins of the device. Consult Samtec at www.samtec.com or call 1-800-SAMTEC-9 for a variety of mating connector options. Table 4 summarizes the analog interface pinout for the TLV320AIC3105EVM..

Table 4. Analog Interface Pinout

PIN NUMBER	SIGNAL	DESCRIPTION
J1.1	HPLCOM	High Power Output Driver (Left Minus or Multifunctional)
J1.2	HPLOUT	High Power Output Driver (Left Plus)
J1.3	HPRCOM	High Power Output Driver (Right Minus or Multifunctional)
J1.4	HPROUT	High Power Output Driver (Right Plus)
J1.5	LINE1LM	MIC1 or LINE1 Analog Input (Left Minus or Multifunctional)
J1.6	LINE1LP	MIC1 or LINE1 Analog Input (Left Plus or Multifunctional)
J1.7	LINE1RM	MIC1 or LINE1 Analog Input (Right Minus or Multifunctional)
J1.8	LINE1RP	MIC1 or LINE1 Analog Input (Right Plus or Multifunctional)
J1.9	AGND	Analog Ground
J1.10	MIC3L	MIC3 Input (Left or Multifunctional)
J1.11	AGND	Analog Ground
J1.12	MIC3R	MIC3 Input (Right or Multifunctional)
J1.13	AGND	Analog Ground
J1.14	MICBIAS	Microphone Bias Voltage Output
J1.15	NC	Not Connected
J1.16	MICDET	Microphone Detect
J1.17	AGND	Analog Ground
J1.18	NC	Not Connected
J1.19	AGND	Analog Ground
J1.20	NC	Not Connected
J2.1	LINE2RM	MIC2 or LINE2 Analog Input (Right Minus or Multifunctional)
J2.2	LINE2RP	MIC2 or LINE2 Analog Input (Right Plus or Multifunctional)
J2.3	LINE2LM	MIC2 or LINE2 Analog Input (Left Minus or Multifunctional)
J2.4	LINE2RP	MIC2 or LINE2 Analog Input (Left Plus or Multifunctional)
J2.5	NC	Not Connected
J2.6	NC	Not Connected
J2.7	LEFT_LOP	Left Line Output (Plus)
J2.8	LEFT_LOM	Left Line Output (Minus)
J2.9	AGND	Analog Ground
J2.10	RIGHT_LOP	Right Line Output (Plus)
J2.11	AGND	Analog Ground
J2.12	RIGHT_LOM	Right Line Output (Minus)
J2.13	AGND	Analog Ground
J2.14	NC	Not Connected
J2.15	NC	Not Connected
J2.16	NC	Not Connected
J2.17	AGND	Analog Ground

Table 4. Analog Interface Pinout (continued)

PIN NUMBER	SIGNAL	DESCRIPTION
J2.18	NC	Not Connected
J2.19	AGND	Analog Ground
J2.20	NC	Not Connected

A.1.2 Analog Screw Terminal Details (J6-7 and J10-14)

In addition to the analog headers, the analog inputs and outputs can also be accessed through alternate connectors, either screw terminals or audio jacks. The stereo microphone input is also tied to J8 and the stereo headphone output (the HP set of outputs) is available at J9.

[Table 5](#) summarizes the screw terminals available on the TLV320AIC3105EVM.

Table 5. Alternate Analog Connectors

DESIGNATOR	PIN 1	PIN 2	PIN3
J6	LINE1L	LINE1R	AGND
J7	AGND	MIC3 IN RIGHT	MIC3 IN LEFT
J10	LEFT OUT -	LEFT OUT +	
J11	RIGHT OUT -	RIGHT OUT +	
J12	(+) HPLOUT	(-) HPLCOM	
J13	(+) HPROUT	(-) HPRCOM	
J14	LINE2L	LINE2R	AGND

A.2 Digital Interface Connectors (J4 and J5)

The TLV320AIC3105EVM is designed to easily interface with multiple control platforms. Samtec part numbers SSW-110-22-F-D-VS-K and TSM-110-01-T-DV-P provide a convenient 10-pin, dual-row header/socket combination at J4 and J5. These headers/sockets provide access to the digital control and serial data pins of the device. Consult Samtec at www.samtec.com or call 1-800- SAMTEC-9 for a variety of mating connector options. Table 6 summarizes the digital interface pinout for the TLV320AIC3105EVM.

Table 6. Digital Interface Pinout

PIN NUMBER	SIGNAL	DESCRIPTION
J4.1	NC	Not Connected
J4.2	GPIO1	General Purpose Input/Output #1
J4.3	SCLK	SPI Serial Clock
J4.4	DGND	Digital Ground
J4.5	NC	Not Connected
J4.6	GPIO2	General Purpose Input/Output #2
J4.7	/SS	SPI Chip Select
J4.8	RESET INPUT	Reset signal input to AIC33EVM
J4.9	NC	Not Connected
J4.10	DGND	Digital Ground
J4.11	MOSI	SPI MOSI Slave Serial Data Input
J4.12	SPI SELECT	Select Pin (SPI vs I ² C Control Mode)
J4.13	MISO	SPI MISO Slave Serial Data Output
J4.14	AIC33 RESET	Reset
J4.15	NC	Not Connected
J4.16	SCL	I ² C Serial Clock
J4.17	NC	Not Connected
J4.18	DGND	Digital Ground
J4.19	NC	Not Connected
J4.20	SDA	I ² C Serial Data Input/Output
J5.1	NC	Not Connected
J5.2	NC	Not Connected
J5.3	BCLK	Audio Serial Data Bus Bit Clock (Input/Output)
J5.4	DGND	Digital Ground
J5.5	NC	Not Connected
J5.6	NC	Not Connected
J5.7	WCLK	Audio Serial Data Bus Word Clock (Input/Output)
J5.8	NC	Not Connected
J5.9	NC	Not Connected
J5.10	DGND	Digital Ground
J5.11	DIN	Audio Serial Data Bus Data Input (Input)
J5.12	NC	Not Connected
J5.13	DOUT	Audio Serial Data Bus Data Output (Output)
J5.14	NC	Not Connected
J5.15	NC	Not Connected
J5.16	SCL	I ² C Serial Clock
J5.17	MCLK	Master Clock Input
J5.18	DGND	Digital Ground
J5.19	NC	Not Connected
J5.20	SDA	I ² C Serial Data Input/Output

Note that J5 comprises the signals needed for an I²S serial digital audio interface; the control interface (I²C and RESET) signals are routed to J16. I²C is actually routed to both connectors; however, the device is connected only to J16.

A.3 Power Supply Connector Pin Header, J3

J3 provides connection to the common power bus for the TLV320AIC3105EVM. Power is supplied on the pins listed in [Table 7](#).

Table 7. Power Supply Pinout

SIGNAL	PIN NUMBER		SIGNAL
NC	J3.1	J3.2	NC
+5VA	J3.3	J3.4	NC
DGND	J3.5	J3.6	AGND
DVDD (1.8V)	J3.7	J3.8	NC
IOVDD (3.3V)	J3.9	J3.10	NC

The TLV320AIC3105EVM-PDK motherboard (the USB-MODEVM interface board) supplies power to J3 of the TLV320AIC3105EVM. Power for the motherboard is supplied either through its USB connection or via terminal blocks on that board.

Appendix B TLV320AIC3105EVM Schematic

The schematic diagram for the modular TLV320AIC3105EVM is provided as a reference.

Revision History		
REV	ECN Number	Approved

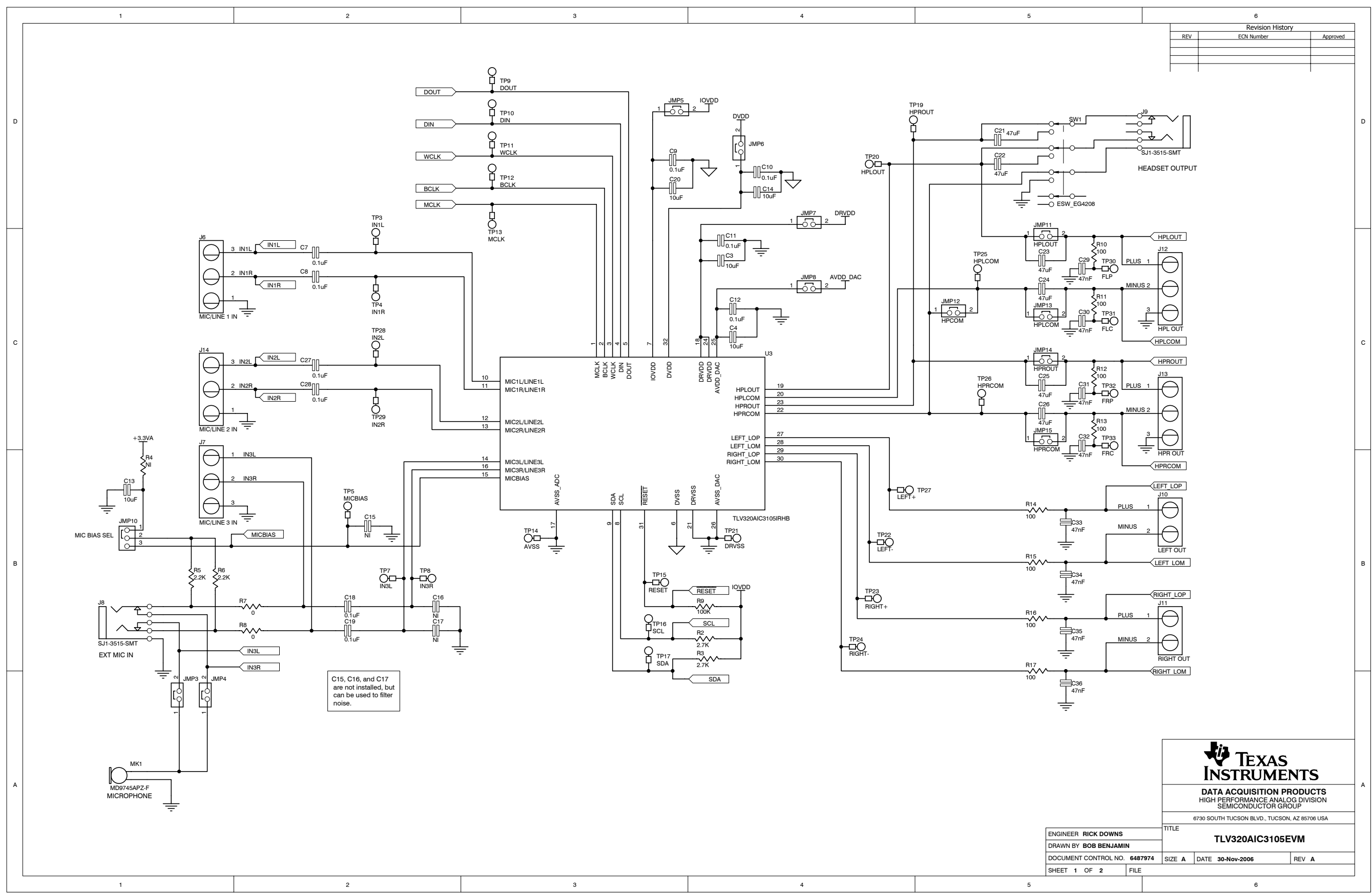

C15, C16, and C17 are not installed, but can be used to filter noise.



TEXAS INSTRUMENTS
 DATA ACQUISITION PRODUCTS
 HIGH PERFORMANCE ANALOG DIVISION
 SEMICONDUCTOR GROUP

8730 SOUTH TUCSON BLVD., TUCSON, AZ 85706 USA

ENGINEER RICK DOWNS	TITLE
DRAWN BY BOB BENJAMIN	TLV320AIC3105EVM
DOCUMENT CONTROL NO. 6487974	SIZE A DATE 30-Nov-2006 REV A
SHEET 1 OF 2	FILE

REVISION HISTORY		
REV	ENGINEERING CHANGE NUMBER	APPROVED

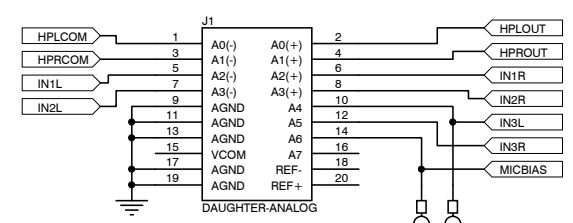

J1A (TOP) = SAM_TSM-110-01-L-DV-P
 J1B (BOTTOM) = SAM_SSW-110-22-F-D-VS-K

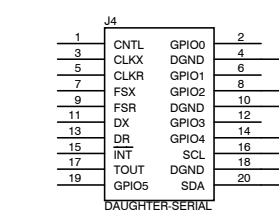

J4A (TOP) = SAM_TSM-110-01-L-DV-P
 J4B (BOTTOM) = SAM_SSW-110-22-F-D-VS-K

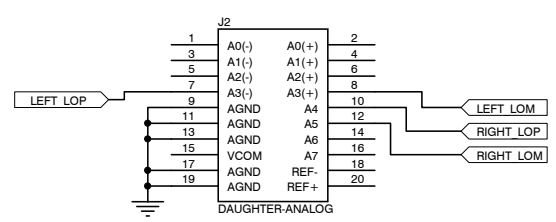
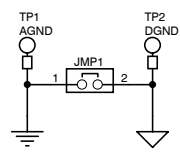
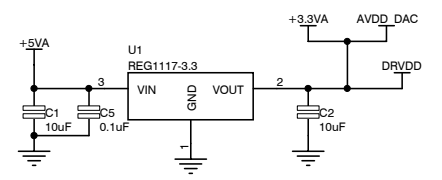

J2A (TOP) = SAM_TSM-110-01-L-DV-P
 J2B (BOTTOM) = SAM_SSW-110-22-F-D-VS-K

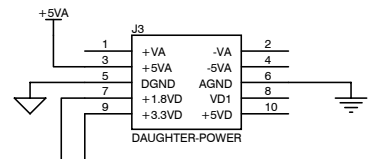

J3A (TOP) = SAM_TSM-105-01-L-DV-P
 J3B (BOTTOM) = SAM_SSW-105-22-F-D-VS-K



J5A (TOP) = SAM_TSM-110-01-L-DV-P
 J5B (BOTTOM) = SAM_SSW-110-22-F-D-VS-K

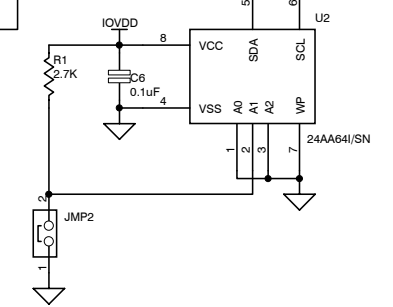

TEXAS INSTRUMENTS
 DATA ACQUISITION PRODUCTS
 HIGH-PERFORMANCE ANALOG DIVISION
 SEMICONDUCTOR GROUP
 6730 SOUTH TUCSON BLVD., TUCSON, AZ 85706 USA

ENGINEER	RICK DOWNS	TITLE	TLV320AIC3105EVM INTERFACE
DRAWN BY	BOB BENJAMIN	DOCUMENT CONTROL NO.	6487974
SHEET	2 OF 2	DATE	30-Nov-2006
FILE		REV	A

Appendix C TLV320AIC3105EVM Layout Views

The board layouts for the modular TLV320AIC3105EVM are illustrated in [Figure 29](#) through [Figure 34](#).

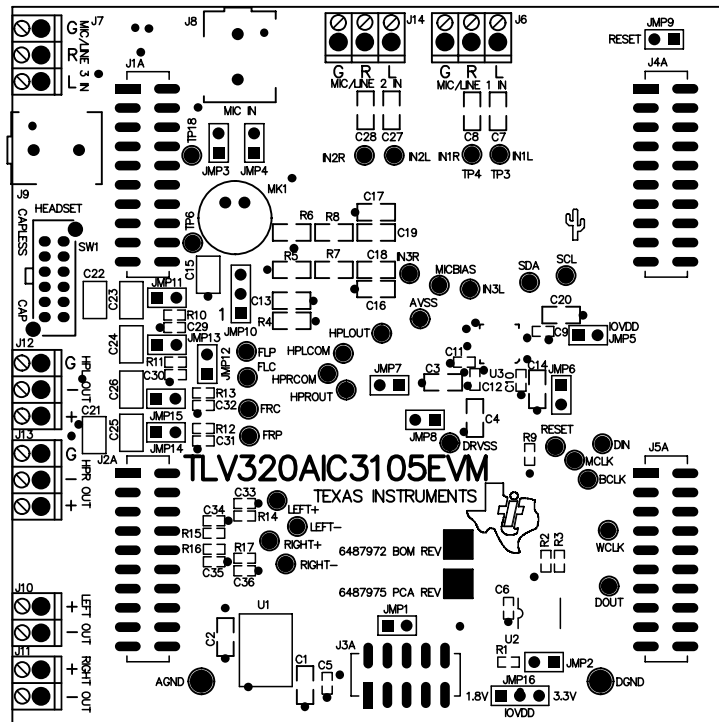

Figure 29. TLV320AIC3105EVM Assembly Layer

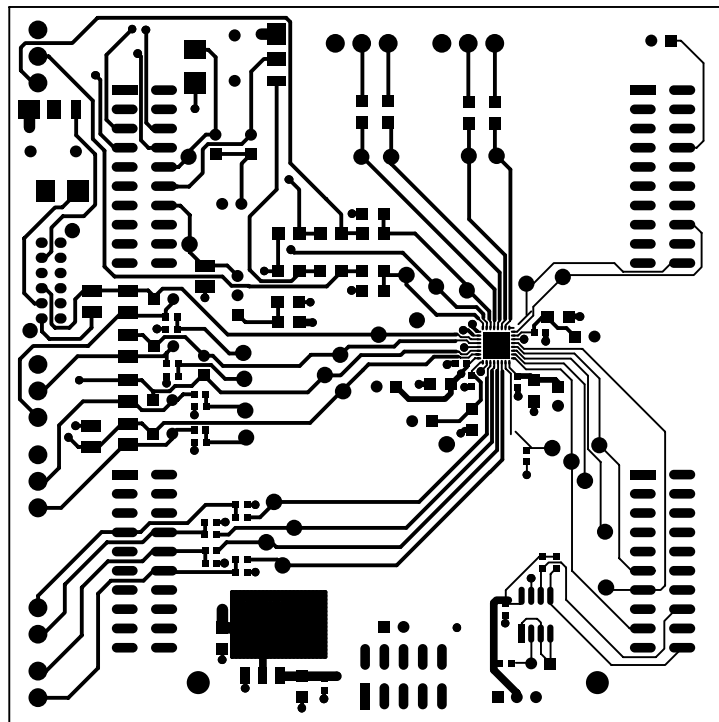

Figure 30. TLV320AIC3105EVM Top Layer

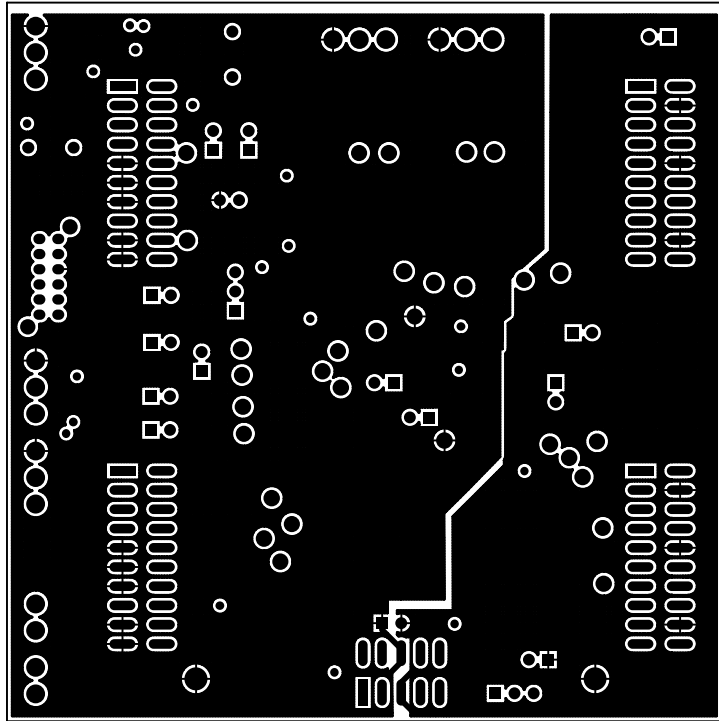

Figure 31. TLV320AIC3105EVM Layer 3

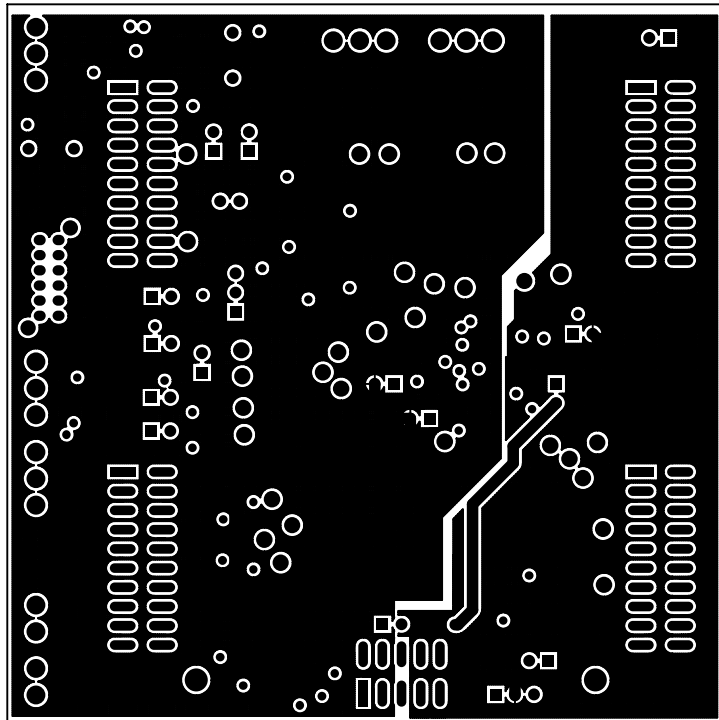

Figure 32. TLV320AIC3105EVM Layer 4

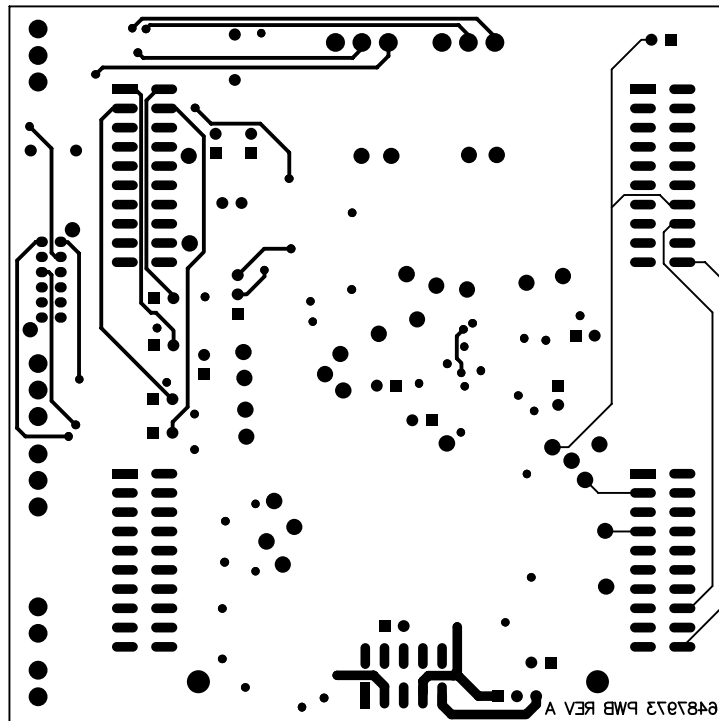

Figure 33. TLV320AIC3105EVM Silk Screen

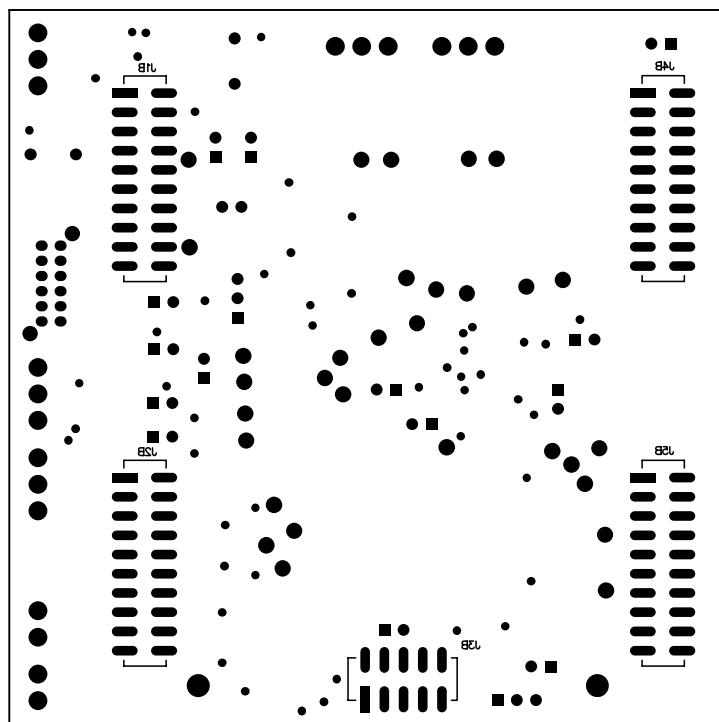

Figure 34. TLV320AIC3105EVM Bottom Layer

Appendix D TLV320AIC3105EVM Bill of Materials

The complete bill of materials for the modular TLV320AIC3105EVM is provided in [Table 8](#).

Table 8. TLV320AIC3105EVM Bill of Materials

QTY	Value	Ref Des	Description	Mfr	Mfr Part No.
2	0	R8, R9	1/4W 5% Chip Resistor	Panasonic	ERJ-8GEY0R00V
10	100	R14–R23	1/10W 1% Chip Resistor	Panasonic	ERJ-3EKF1000V
2	2.2k	R6, R7	1/4W 5% Chip Resistor	Panasonic	ERJ-8GEYJ222V
3	2.7K	R11–R13	1/10W 5% Chip Resistor	Panasonic	ERJ-3GEYJ272V
1	100K	R10	1/10W 5% Chip Resistor	Panasonic	ERJ-3GEYJ104V
5	NI	R1–R5	Chip Resistor	Not Installed	—
10	47 nF	C35–C44	50V Ceramic chip capacitor, ±10%, X7R	TDK	C1608X7R1H473K
7	0.1 µF	C12–C17, C34	16V Ceramic Chip Capacitor, ±10%, X7R	TDK	C1608X7R1E104K
10	0.1 µF	C4–C11, C21, C22	100V Ceramic Chip Capacitor, ±10%, X7R	TDK	C3216X7R2E104K
8	10 µF	C1–C3, C23–C27	6.3V Ceramic Chip Capacitor, ±10%, X5R	TDK	C3216X5R0J106K
6	47 µF	C28–C33	6.3V Ceramic Chip Capacitor, ±20%, X5R	TDK	C3225X5R0J476M
2	NI	C19, C20	Ceramic Chip Capacitor	Not Installed	—
1	NI	C18	Ceramic Chip Capacitor	Not Installed	—
1		U1	Audio Codec	Texas Instruments	TLV320AIC3105IZQE
1		U2	3.3V LDO Voltage Regulator	Texas Instruments	REG1117-3.3
1		U3	64K I2C EEPROM	MicroChip	24AA64-I/SN
7		J1–J4, J8–J10	Screw Terminal Block, 2 Position	On Shore Technology	ED555/2DS
3		J5, J11, J12	Screw Terminal Block, 3 Position	On Shore Technology	ED555/3DS
2		J6, J7	3,5 mm Audio Jack, T-R-S, SMD	CUI Inc.	SJ1-3515-SMT
			or alternate	KobiConn	161-3335-E
4		J1A, J14A, J16A, J17A	20 Pin SMT Plug	Samtec	TSM-110-01-L-DV-P
4		J1B, J14B, J16B, J17B	20 pin SMT Socket	Samtec	SSW-110-22-F-D-VS-K
1		J15A	10 Pin SMT Plug	Samtec	TSM-105-01-L-DV-P
1		J15B	10 pin SMT Socket	Samtec	SSW-105-22-F-D-VS-K
1		N/A	TLV320AIC3105EVM PWB	Texas Instruments	6487980
10		JMP2, JMP3, JMP9, JMP13–JMP19	2 Position Jumper, 0.1" spacing	Samtec	TSW-102-07-L-S
5		JMP4–JMP8	Bus Wire (18-22 Gauge)	—	—
2		JMP1, JMP20	3 Position Jumper, 0.1" spacing	Samtec	TSW-103-07-L-S
3		JMP10–JMP12	3 × 2 Position Header, 0.1" spacing	Samtec	TSW-103-07-L-D
1		MK1	Omnidirectional Microphone Cartridge	Knowles Acoustics	MD9745APZ-F
1		SW1	4PDT Right Angle Switch	E-Switch	EG4208
45	Not Installed	TP1–TP39, TP42–TP47	Miniature Test Point Terminal	Keystone Electronics	5000
2		TP40, TP41	Multipurpose Test Point Terminal	Keystone Electronics	5011
15		N/A	Header Shorting Block	Samtec	SNT-100-BK-T

ATTENTION: All components should be RoHS compliant. Some part numbers may be either leaded or RoHS. Verify purchased components are RoHS compliant.

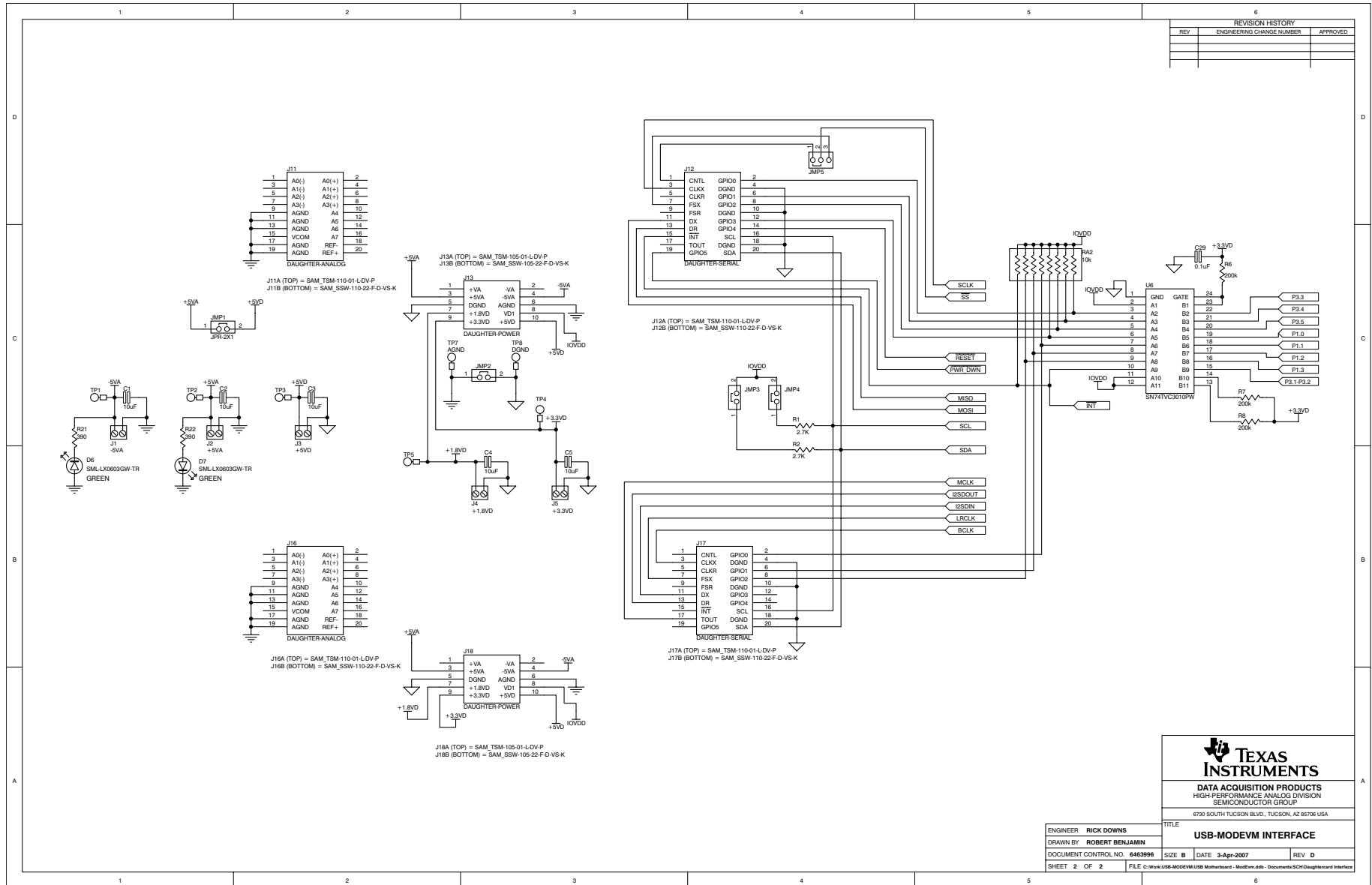

Figure 36. USB-MODEVM Interface Board Schematic (2 of 2)

Appendix F USB-MODEVM Layout Views

The USB-MODEVM interface board layouts (included only in the TLV320AIC3105EVM-PDK) are illustrated in Figure 37 through Figure 39.

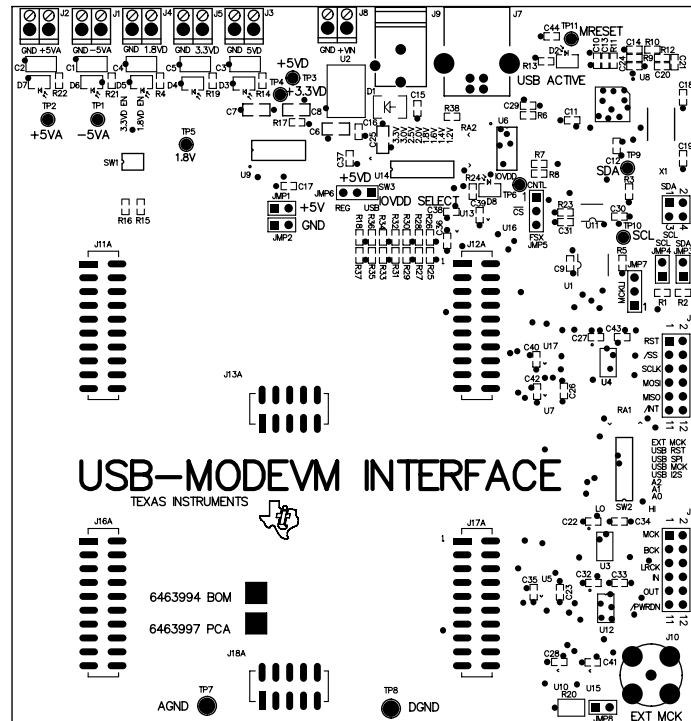

Figure 37. USB-MODEVM Assembly Layer

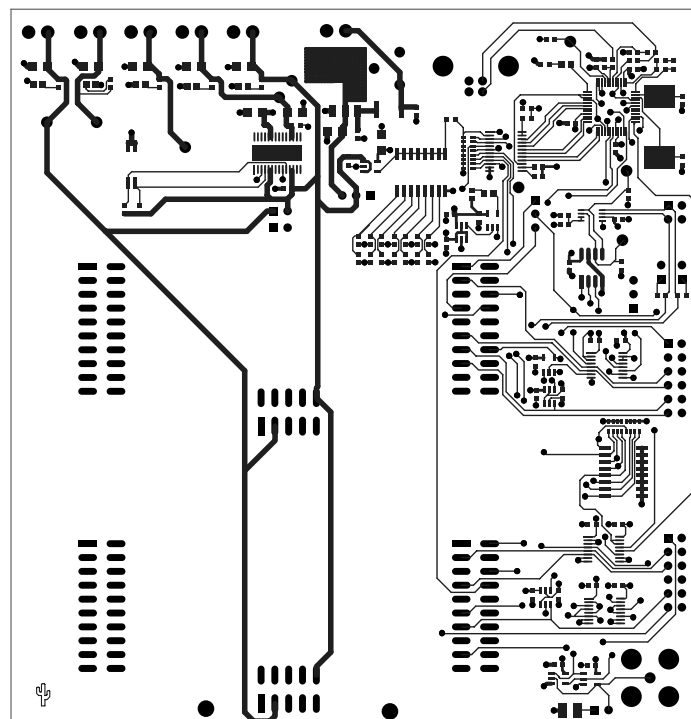

Figure 38. USB-MODEVM Top Layer

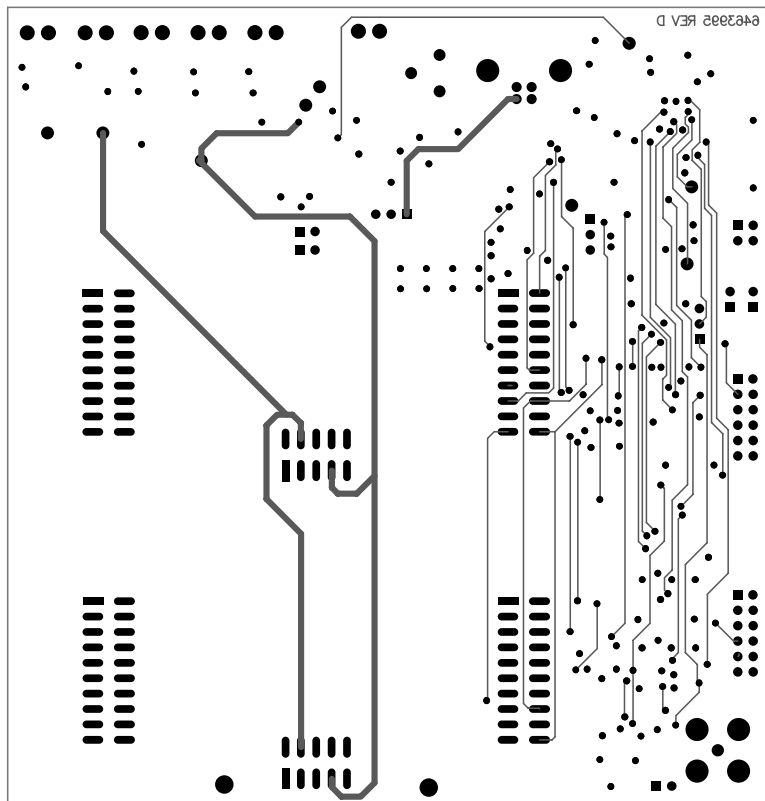

Figure 39. USB-MODEVM Bottom Layer

Appendix G USB-MODEVM Bill of Materials

The complete bill of materials for USB-MODEVM interface board (included only in the TLV320AIC3105EVM-PDK) is provided in [Table 9](#).

Table 9. USB-MODEVM Bill of Materials

Designators	Description	Manufacturer	Mfr Part Number
R4	10Ω 1/10W 5% Chip Resistor	Panasonic	ERJ-3GEYJ100V
R10, R11	27.4Ω 1/16W 1% Chip Resistor	Panasonic	ERJ-3EKF27R4V
R20	75Ω 1/4W 1% Chip Resistor	Panasonic	ERJ-14NF75R0U
R19	220Ω 1/10W 5% Chip Resistor	Panasonic	ERJ-3GEYJ221V
R14, R21, R22	390Ω 1/10W 5% Chip Resistor	Panasonic	ERJ-3GEYJ391V
R13	649Ω 1/16W 1% Chip Resistor	Panasonic	ERJ-3EKF6490V
R9	1.5KΩ 1/10W 5% Chip Resistor	Panasonic	ERJ-3GEYJ1352V
R1–R3, R5–R8	2.7KΩ 1/10W 5% Chip Resistor	Panasonic	ERJ-3GEYJ272V
R12	3.09KΩ 1/16W 1% Chip Resistor	Panasonic	ERJ-3EKF3091V
R15, R16	10KΩ 1/10W 5% Chip Resistor	Panasonic	ERJ-3GEYJ1303V
R17, R18	100kΩ 1/10W 5% Chip Resistor	Panasonic	ERJ-3GEYJ1304V
RA1	10KΩ 1/8W Octal Isolated Resistor Array	CTS Corporation	742C163103JTR
C18, C19	33pF 50V Ceramic Chip Capacitor, ±5%, NPO	TDK	C1608C0G1H330J
C13, C14	47pF 50V Ceramic Chip Capacitor, ±5%, NPO	TDK	C1608C0G1H470J
C20	100pF 50V Ceramic Chip Capacitor, ±5%, NPO	TDK	C1608C0G1H101J
C21	1000pF 50V Ceramic Chip Capacitor, ±5%, NPO	TDK	C1608C0G1H102J
C15	0.1μF 16V Ceramic Chip Capacitor, ±10%, X7R	TDK	C1608X7R1C104K
C16, C17	0.33μF 16V Ceramic Chip Capacitor, ±20%, Y5V	TDK	C1608X5R1C334K
C9–C12, C22–C28	1μF 6.3V Ceramic Chip Capacitor, ±10%, X5R	TDK	C1608X5R0J1305K
C1–C8	10μF 6.3V Ceramic Chip Capacitor, ±10%, X5R	TDK	C3216X5R0J1306K
D1	50V, 1A, Diode MELF SMD	Micro Commercial Components	DL4001
D2	Yellow Light Emitting Diode	Lumex	SML-LX0603YW-TR
D3– D7	Green Light Emitting Diode	Lumex	SML-LX0603GW-TR
D5	Red Light Emitting Diode	Lumex	SML-LX0603IW-TR
Q1, Q2	N-Channel MOSFET	Zetex	ZXMN6A07F
X1	6MHz Crystal SMD	Epson	MA-505 6.000M-C0
U8	USB Streaming Controller	Texas Instruments	TAS1020BPFB
U2	5V LDO Regulator	Texas Instruments	REG1117-5
U9	3.3V/1.8V Dual Output LDO Regulator	Texas Instruments	TPS767D318PWP
U3, U4	Quad, 3-State Buffers	Texas Instruments	SN74LVC125APW
U5–U7	Single IC Buffer Driver with Open Drain o/p	Texas Instruments	SN74LVC1G07DBVR
U10	Single 3-State Buffer	Texas Instruments	SN74LVC1G125DBVR
U1	64K 2-Wire Serial EEPROM I ² C	Microchip	24LC64I/SN
	USB-MODEVM PCB	Texas Instruments	6463995
TP1–TP6, TP9–TP11	Miniature test point terminal	Keystone Electronics	5000
TP7, TP8	Multipurpose test point terminal	Keystone Electronics	5011
J7	USB Type B Slave Connector Thru-Hole	Mill-Max	897-30-004-90-000000
J13, J2–J5, J8	2-position terminal block	On Shore Technology	ED555/2DS
J9	2.5mm power connector	CUI Stack	PJ-102B
J130	BNC connector, female, PC mount	AMP/Tyco	414305-1
J131A, J132A, J21A, J22A	20-pin SMT plug	Samtec	TSM-110-01-L-DV-P
J131B, J132B, J21B, J22B	20-pin SMT socket	Samtec	SSW-110-22-F-D-VS-K
J133A, J23A	10-pin SMT plug	Samtec	TSM-105-01-L-DV-P
J133B, J23B	10-pin SMT socket	Samtec	SSW-105-22-F-D-VS-K
J6	4-pin double row header (2x2) 0.1"	Samtec	TSW-102-07-L-D
J134, J135	12-pin double row header (2x6) 0.1"	Samtec	TSW-106-07-L-D

Table 9. USB-MODEVM Bill of Materials (continued)

Designators	Description	Manufacturer	Mfr Part Number
JMP1–JMP4	2-position jumper, 0.1" spacing	Samtec	TSW-102-07-L-S
JMP8–JMP14	2-position jumper, 0.1" spacing	Samtec	TSW-102-07-L-S
JMP5, JMP6	3-position jumper, 0.1" spacing	Samtec	TSW-103-07-L-S
JMP7	3-position dual row jumper, 0.1" spacing	Samtec	TSW-103-07-L-D
SW1	SMT, half-pitch 2-position switch	C&K Division, ITT	TDA02H0SK1
SW2	SMT, half-pitch 8-position switch	C&K Division, ITT	TDA08H0SK1
	Jumper plug	Samtec	SNT-100-BK-T

Appendix H USB-MODEVM Protocol

H.1 USB-MODEVM Protocol

The USB-MODEVM is defined to be a vendor-specific class and is identified on the PC system as an NI-VISA device. Because the TAS1020 has several routines in its ROM which are designed for use with HID-class devices, HID-like structures are used, even though the USB-MODEVM is not an HID-class device. Data is passed from the PC to the TAS1020 using the control endpoint.

Data is sent in an HIDSETREPORT (see [Table 10](#)):

**Table 10. USB Control Endpoint
HIDSETREPORT Request**

Part	Value	Description
bmRequestType	0x21	00100001
bRequest	0x09	SET_REPORT
wValue	0x00	don't care
wIndex	0x03	HID interface is index 3
wLength	calculated by host	
Data		Data packet described as follows

The data packet consists of the following bytes, shown in [Table 11](#):

Table 11. Data Packet Configuration

BYTE NUMBER	TYPE	DESCRIPTION														
0	Interface	Specifies serial interface and operation. The two values are logically ORed. Operation: <table style="margin-left: 40px;"> <tr> <td>READ</td> <td>0x00</td> </tr> <tr> <td>WRITE</td> <td>0x10</td> </tr> </table> Interface: <table style="margin-left: 40px;"> <tr> <td>GPIO</td> <td>0x08</td> </tr> <tr> <td>SPI_16</td> <td>0x04</td> </tr> <tr> <td>I2C_FAST</td> <td>0x02</td> </tr> <tr> <td>I2C_STD</td> <td>0x01</td> </tr> <tr> <td>SPI_8</td> <td>0x00</td> </tr> </table>	READ	0x00	WRITE	0x10	GPIO	0x08	SPI_16	0x04	I2C_FAST	0x02	I2C_STD	0x01	SPI_8	0x00
READ	0x00															
WRITE	0x10															
GPIO	0x08															
SPI_16	0x04															
I2C_FAST	0x02															
I2C_STD	0x01															
SPI_8	0x00															
1	I ² C Slave Address	Slave address of I ² C device or MSB of 16-bit reg addr for SPI														
2	Length	Length of data to write/read (number of bytes)														
3	Register address	Address of register for I ² C or 8-bit SPI; LSB of 16-bit address for SPI														
4..64	Data	Up to 60 data bytes could be written at a time. EP0 maximum length is 64. The return packet is limited to 42 bytes; so, it is advised to send only 32 bytes at any one time.														

Example usage:

Write two bytes (AA, 55) to device starting at register 5 of an I²C device with address A0:

```
[0] 0x11
[1] 0xA0
[2] 0x02
[3] 0x05
[4] 0xAA
[5] 0x55
```

Do the same with a fast mode I²C device:

```
[0] 0x12
[1] 0xA0
[2] 0x02
[3] 0x05
[4] 0xAA
[5] 0x55
```

Now with an SPI device which uses an 8-bit register address:

```
[0] 0x10
[1] 0xA0
[2] 0x02
[3] 0x05
[4] 0xAA
[5] 0x55
```

Now, do a 16-bit register address, as found on parts like the TSC2101. Assume the register address (command word) is **0x10E0**:

```
[0] 0x14
[1] 0x10 --> Note: the I2C address now serves as MSB of reg addr.
[2] 0x02
[3] 0xE0
[4] 0xAA
[5] 0x55
```

In each case, the TAS1020 will return, in an HID interrupt packet, the following:

[0] interface byte | status

status:

```
REQ_ERROR 0x80
INTF_ERROR 0x40
REQ_DONE 0x20
```

[1] for I²C interfaces, the I²C address as sent

for SPI interfaces, the read back data from SPI line for transmission of the corresponding byte

[2] length as sent

[3] for I²C interfaces, the reg address as sent

for SPI interfaces, the read back data from SPI line for transmission of the corresponding byte

[4..60] echo of data packet sent

If the command is sent with no problem, the returning byte [0] should be the same as the sent one logically ORed with 0x20. In the preceding first example, the returning packet should be:

```
[0] 0x31
[1] 0xA0
[2] 0x02
[3] 0x05
[4] 0xAA
[5] 0x55
```

If for some reason the interface fails (for example, the I²C device does not acknowledge), it would come back as:

```
[0] 0x51 --> interface | INTF_ERROR
[1] 0xA0
[2] 0x02
[3] 0x05
[4] 0xAA
[5] 0x55
```

If the request is malformed, that is, the interface byte (byte [0]) takes on a value which is not described above, the return packet would be:

```
[0] 0x93 --> the user sent 0x13, which is not valid, so 0x93 returned
[1] 0xA0
[2] 0x02
[3] 0x05
[4] 0xAA
[5] 0x55
```

The preceding examples used writes. Reading is similar:

Read two bytes from device starting at register 5 of an I²C device with address A0:

```
[0] 0x01
[1] 0xA0
[2] 0x02
[3] 0x05
```

The return packet should be

```
[0] 0x21
[1] 0xA0
[2] 0x02
[3] 0x05
[4] 0xAA
[5] 0x55
```

assuming that the preceding written values starting at Register 5 were actually written to the device.

H.2 GPIO Capability

The USB-MODEVM has seven GPIO lines. Access them by specifying the interface to be 0x08, and then using the standard format for packets—but addresses are unnecessary. The GPIO lines are mapped into one byte (see [Table 12](#)):

Table 12. GPIO Pin Assignments

Bit 7	6	5	4	3	2	1	0
x	P3.5	P3.4	P3.3	P1.3	P1.2	P1.1	P1.0

Example: write P3.5 to a 1, set all others to 0:

```
[0] 0x18 --> write, GPIO
[1] 0x00 --> this value is ignored
[2] 0x01 --> length - ALWAYS a 1
[3] 0x00 --> this value is ignored
[4] 0x40 --> 01000000
```

The user may also read back from the GPIO to see the state of the pins. Assume the previous example was just written to the port pins.

Example: read the GPIO

```
[0] 0x08 --> read, GPIO
[1] 0x00 --> this value is ignored
[2] 0x01 --> length - ALWAYS a 1
[3] 0x00 --> this value is ignored
```

The return packet should be:

```
[0] 0x28
[1] 0x00
[2] 0x01
[3] 0x00
[4] 0x40
```

H.3 Writing Scripts

A script is simply a text file that contains data to send to the serial control buses. The scripting language is quite simple, as is the parser for the language. Therefore, the program is not forgiving about mistakes made in the source script file, but the formatting of the file is simple. Consequently, mistakes should be rare.

Each line in a script file is one command. No provision is made for extending lines beyond one line. A line is terminated by a carriage return.

The first character of a line is the command. Commands are:

I Set interface bus to use
r Read from the serial control bus
w Write to the serial control bus
Comment
b Break
d Delay

The first command, **I**, sets the interface to use the commands that follow. This command must be followed by one of the following parameters:

i2cstd	Standard mode I ² C bus
i2cfast	Fast mode I ² C bus
spi8	SPI bus with 8-bit register addressing
spi16	SPI bus with 16-bit register addressing
gpio	Use the USB-MODEVM GPIO capability

For example, if a fast mode I²C bus is used, the script begins with:

I i2cfast

No data follows the break command. Anything following a comment command is ignored by the parser, provided that it is on the same line. The delay command allows the user to specify a time, in milliseconds, that the script pauses before proceeding.

NOTE: UNLIKE ALL OTHER NUMBERS USED IN THE SCRIPT COMMANDS, THE DELAY TIME IS ENTERED IN A DECIMAL FORMAT. Also, note that because of latency in the USB bus as well as the time it takes the processor on the USB-MODEVM to handle requests, the delay time may be imprecise.

A series of byte values follows either a read or write command. Each byte value is expressed in hexadecimal, and each byte must be separated by a space. Commands are interpreted and sent to the TAS1020 by the program using the protocol described in [Section H.1](#).

The first byte following a read or write command is the I²C slave address of the device (if I²C is used) or the first data byte to write (if SPI is used—note that SPI interfaces are not standardized on protocols, so the meaning of this byte varies with the device being addressed on the SPI bus). The second byte is the starting register address that data is to be written to (again, with I²C; SPI varies—see [Section H.1](#) for additional information about which variations may be necessary for a particular SPI mode). Following these two bytes are data, if writing; if reading, the third byte value is the number of bytes to read, (expressed in hexadecimal).

For example, to write the values 0xAA 0x55 to an I²C device with a slave address of 0x90, starting at a register address of 0x03, one would write:

```
#example script
I i2cfast
w 90 03 AA 55
r 90 03 2
```

This script begins with a comment, specifies that a fast I²C bus will be used, and then writes 0xAA 0x55 to the I²C slave device at address 0x90, writing the values into registers 0x03 and 0x04. The script then reads back two bytes from the same device starting at register address 0x03. Note that the slave device value does not change. It is unnecessary to set the R/W bit for I²C devices in the script; the read or write commands does that.

The following example uses an SPI device that requires 16-bit register addresses:

```
# setup TSC2101 for input and output
# uses SPI16 interface
# this script sets up DAC and ADC at full volume,
    input from onboard mic
#
# Page 2: Audio control registers
w 10 00 00 00 80 00 00 00 45 31 44 FD 40 00 31
    C4
w 13 60 11 20 00 00 00 80 7F 00 C5 FE 31 40 7C 00 02
    00 C4 00 00 00 23 10 FE 00 FE 00
```

Note that blank lines are allowed. However, ensure that the script does not end with a blank line. Although ending with a blank line does not cause the script to fail, the program executes that line, and therefore, may prevent the user from seeing data that was written or read back on the previous command.

In this example, the first two bytes of each command are the command word to send to the TSC2101 (0x1000, 0x1360); these are followed by data to write to the device starting at the address specified in the command word. The second line may wrap in the viewer being used to look like more than one line; careful examination shows, however, that only one carriage return is on that line, following the last **00**.

Any text editor can be used to write these scripts; Jedit is an editor that is highly recommended for general use. For more information, go to: <http://www.jedit.org>.

Once the script is written, it can be used in the command window by running the program, and then selecting *Open Command File...* from the File menu. Locate the script and open it. The script then is displayed in the command buffer. The user can edit the script once it is in the buffer, but saving of the command buffer is not possible at this time (this feature may be added at a later date).

Once the script is in the command buffer, it may be executed by pressing the *Execute Command Buffer* button. If the script contains breakpoints, the script executes to that point, and the user is presented with a dialog box with a button to press to continue executing the script. When ready to proceed, the user pushes that button, and the script continues.

The following is an example of a (partial) script with breakpoints:

```
# setup AIC33 for input and output
# uses I2C interface
I i2cfast
# reg 07 - codec datapath
w 30 07 8A
r 30 07 1
d 1000
# regs 15/16 - ADC volume, unmute and set to
    0dB
w 30 0F 00 00
r 30 0F 2
b
```

This script writes the value 8A at register 7, then reads it back to verify that the write was good. A delay of 1000 ms (one second) is placed after the read to pause the script operation. When the script continues, the values **00 00** are written starting at register 0F. This output is verified by reading two bytes and pausing the script again, this time with a break. The script does not continue until the user allows it to by pressing *OK* in the dialog box that is displayed due to the break.

Revision History

Changes from Original (August 2007) to A Revision	Page
• Added table describing the USB-MODEVM jumpers.	5
• Added instructions concerning Windows 7 driver installation	5
• Changed contents of the List of Jumpers.	6
• Changed USB-MODEVM schematics to revision D.	42
• Added USB-MODEVM revision D board layout views.	44

NOTE: Page numbers for previous revisions may differ from page numbers in the current version.

EVALUATION BOARD/KIT/MODULE (EVM) ADDITIONAL TERMS

Texas Instruments (TI) provides the enclosed Evaluation Board/Kit/Module (EVM) under the following conditions:

The user assumes all responsibility and liability for proper and safe handling of the goods. Further, the user indemnifies TI from all claims arising from the handling or use of the goods.

Should this evaluation board/kit not meet the specifications indicated in the User's Guide, the board/kit may be returned within 30 days from the date of delivery for a full refund. THE FOREGOING LIMITED WARRANTY IS THE EXCLUSIVE WARRANTY MADE BY SELLER TO BUYER AND IS IN LIEU OF ALL OTHER WARRANTIES, EXPRESSED, IMPLIED, OR STATUTORY, INCLUDING ANY WARRANTY OF MERCHANTABILITY OR FITNESS FOR ANY PARTICULAR PURPOSE. EXCEPT TO THE EXTENT OF THE INDEMNITY SET FORTH ABOVE, NEITHER PARTY SHALL BE LIABLE TO THE OTHER FOR ANY INDIRECT, SPECIAL, INCIDENTAL, OR CONSEQUENTIAL DAMAGES.

Please read the User's Guide and, specifically, the Warnings and Restrictions notice in the User's Guide prior to handling the product. This notice contains important safety information about temperatures and voltages. For additional information on TI's environmental and/or safety programs, please visit www.ti.com/esh or contact TI.

No license is granted under any patent right or other intellectual property right of TI covering or relating to any machine, process, or combination in which such TI products or services might be or are used. TI currently deals with a variety of customers for products, and therefore our arrangement with the user is not exclusive. TI assumes no liability for applications assistance, customer product design, software performance, or infringement of patents or services described herein.

REGULATORY COMPLIANCE INFORMATION

As noted in the EVM User's Guide and/or EVM itself, this EVM and/or accompanying hardware may or may not be subject to the Federal Communications Commission (FCC) and Industry Canada (IC) rules.

For EVMs **not** subject to the above rules, this evaluation board/kit/module is intended for use for ENGINEERING DEVELOPMENT, DEMONSTRATION OR EVALUATION PURPOSES ONLY and is not considered by TI to be a finished end product fit for general consumer use. It generates, uses, and can radiate radio frequency energy and has not been tested for compliance with the limits of computing devices pursuant to part 15 of FCC or ICES-003 rules, which are designed to provide reasonable protection against radio frequency interference. Operation of the equipment may cause interference with radio communications, in which case the user at his own expense will be required to take whatever measures may be required to correct this interference.

General Statement for EVMs including a radio

User Power/Frequency Use Obligations: This radio is intended for development/professional use only in legally allocated frequency and power limits. Any use of radio frequencies and/or power availability of this EVM and its development application(s) must comply with local laws governing radio spectrum allocation and power limits for this evaluation module. It is the user's sole responsibility to only operate this radio in legally acceptable frequency space and within legally mandated power limitations. Any exceptions to this are strictly prohibited and unauthorized by Texas Instruments unless user has obtained appropriate experimental/development licenses from local regulatory authorities, which is responsibility of user including its acceptable authorization.

For EVMs annotated as FCC – FEDERAL COMMUNICATIONS COMMISSION Part 15 Compliant

Caution

This device complies with part 15 of the FCC Rules. Operation is subject to the following two conditions: (1) This device may not cause harmful interference, and (2) this device must accept any interference received, including interference that may cause undesired operation.

Changes or modifications not expressly approved by the party responsible for compliance could void the user's authority to operate the equipment.

FCC Interference Statement for Class A EVM devices

This equipment has been tested and found to comply with the limits for a Class A digital device, pursuant to part 15 of the FCC Rules. These limits are designed to provide reasonable protection against harmful interference when the equipment is operated in a commercial environment. This equipment generates, uses, and can radiate radio frequency energy and, if not installed and used in accordance with the instruction manual, may cause harmful interference to radio communications. Operation of this equipment in a residential area is likely to cause harmful interference in which case the user will be required to correct the interference at his own expense.

FCC Interference Statement for Class B EVM devices

This equipment has been tested and found to comply with the limits for a Class B digital device, pursuant to part 15 of the FCC Rules. These limits are designed to provide reasonable protection against harmful interference in a residential installation. This equipment generates, uses and can radiate radio frequency energy and, if not installed and used in accordance with the instructions, may cause harmful interference to radio communications. However, there is no guarantee that interference will not occur in a particular installation. If this equipment does cause harmful interference to radio or television reception, which can be determined by turning the equipment off and on, the user is encouraged to try to correct the interference by one or more of the following measures:

- Reorient or relocate the receiving antenna.
- Increase the separation between the equipment and receiver.
- Connect the equipment into an outlet on a circuit different from that to which the receiver is connected.
- Consult the dealer or an experienced radio/TV technician for help.

For EVMs annotated as IC – INDUSTRY CANADA Compliant

This Class A or B digital apparatus complies with Canadian ICES-003.

Changes or modifications not expressly approved by the party responsible for compliance could void the user's authority to operate the equipment.

Concerning EVMs including radio transmitters

This device complies with Industry Canada licence-exempt RSS standard(s). Operation is subject to the following two conditions: (1) this device may not cause interference, and (2) this device must accept any interference, including interference that may cause undesired operation of the device.

Concerning EVMs including detachable antennas

Under Industry Canada regulations, this radio transmitter may only operate using an antenna of a type and maximum (or lesser) gain approved for the transmitter by Industry Canada. To reduce potential radio interference to other users, the antenna type and its gain should be so chosen that the equivalent isotropically radiated power (e.i.r.p.) is not more than that necessary for successful communication.

This radio transmitter has been approved by Industry Canada to operate with the antenna types listed in the user guide with the maximum permissible gain and required antenna impedance for each antenna type indicated. Antenna types not included in this list, having a gain greater than the maximum gain indicated for that type, are strictly prohibited for use with this device.

Cet appareil numérique de la classe A ou B est conforme à la norme NMB-003 du Canada.

Les changements ou les modifications pas expressément approuvés par la partie responsable de la conformité ont pu vider l'autorité de l'utilisateur pour actionner l'équipement.

Concernant les EVMs avec appareils radio

Le présent appareil est conforme aux CNR d'Industrie Canada applicables aux appareils radio exempts de licence. L'exploitation est autorisée aux deux conditions suivantes : (1) l'appareil ne doit pas produire de brouillage, et (2) l'utilisateur de l'appareil doit accepter tout brouillage radioélectrique subi, même si le brouillage est susceptible d'en compromettre le fonctionnement.

Concernant les EVMs avec antennes détachables

Conformément à la réglementation d'Industrie Canada, le présent émetteur radio peut fonctionner avec une antenne d'un type et d'un gain maximal (ou inférieur) approuvé pour l'émetteur par Industrie Canada. Dans le but de réduire les risques de brouillage radioélectrique à l'intention des autres utilisateurs, il faut choisir le type d'antenne et son gain de sorte que la puissance isotrope rayonnée équivalente (p.i.r.e.) ne dépasse pas l'intensité nécessaire à l'établissement d'une communication satisfaisante.

Le présent émetteur radio a été approuvé par Industrie Canada pour fonctionner avec les types d'antenne énumérés dans le manuel d'usage et ayant un gain admissible maximal et l'impédance requise pour chaque type d'antenne. Les types d'antenne non inclus dans cette liste, ou dont le gain est supérieur au gain maximal indiqué, sont strictement interdits pour l'exploitation de l'émetteur.

【Important Notice for Users of EVMs for RF Products in Japan】

This development kit is NOT certified as Confirming to Technical Regulations of Radio Law of Japan

If you use this product in Japan, you are required by Radio Law of Japan to follow the instructions below with respect to this product:

1. Use this product in a shielded room or any other test facility as defined in the notification #173 issued by Ministry of Internal Affairs and Communications on March 28, 2006, based on Sub-section 1.1 of Article 6 of the Ministry's Rule for Enforcement of Radio Law of Japan,
2. Use this product only after you obtained the license of Test Radio Station as provided in Radio Law of Japan with respect to this product, or
3. Use of this product only after you obtained the Technical Regulations Conformity Certification as provided in Radio Law of Japan with respect to this product. Also, please do not transfer this product, unless you give the same notice above to the transferee. Please note that if you could not follow the instructions above, you will be subject to penalties of Radio Law of Japan.

Texas Instruments Japan Limited
(address) 24-1, Nishi-Shinjuku 6 chome, Shinjuku-ku, Tokyo, Japan

<http://www.tij.co.jp>

【無線電波を送信する製品の開発キットをお使いになる際の注意事項】

本開発キットは技術基準適合証明を受けておりません。

本製品のご使用に際しては、電波法遵守のため、以下のいずれかの措置を取っていただく必要がありますのでご注意ください。

1. 電波法施行規則第6条第1項第1号に基づく平成18年3月28日総務省告示第173号で定められた電波暗室等の試験設備でご使用いただく。
2. 実験局の免許を取得後ご使用いただく。
3. 技術基準適合証明を取得後ご使用いただく。

なお、本製品は、上記の「ご使用にあたっての注意」を譲渡先、移転先に通知しない限り、譲渡、移転できないものとします。

上記を遵守頂けない場合は、電波法の罰則が適用される可能性があることをご留意ください。

日本テキサス・インスツルメンツ株式会社

東京都新宿区西新宿 6 丁目 2 4 番 1 号

西新宿三井ビル

<http://www.tij.co.jp>

EVALUATION BOARD/KIT/MODULE (EVM) WARNINGS, RESTRICTIONS AND DISCLAIMERS

For Feasibility Evaluation Only, in Laboratory/Development Environments. Unless otherwise indicated, this EVM is not a finished electrical equipment and not intended for consumer use. It is intended solely for use for preliminary feasibility evaluation in laboratory/development environments by technically qualified electronics experts who are familiar with the dangers and application risks associated with handling electrical mechanical components, systems and subsystems. It should not be used as all or part of a finished end product.

Your Sole Responsibility and Risk. You acknowledge, represent and agree that:

1. You have unique knowledge concerning Federal, State and local regulatory requirements (including but not limited to Food and Drug Administration regulations, if applicable) which relate to your products and which relate to your use (and/or that of your employees, affiliates, contractors or designees) of the EVM for evaluation, testing and other purposes.
2. You have full and exclusive responsibility to assure the safety and compliance of your products with all such laws and other applicable regulatory requirements, and also to assure the safety of any activities to be conducted by you and/or your employees, affiliates, contractors or designees, using the EVM. Further, you are responsible to assure that any interfaces (electronic and/or mechanical) between the EVM and any human body are designed with suitable isolation and means to safely limit accessible leakage currents to minimize the risk of electrical shock hazard.
3. Since the EVM is not a completed product, it may not meet all applicable regulatory and safety compliance standards (such as UL, CSA, VDE, CE, RoHS and WEEE) which may normally be associated with similar items. You assume full responsibility to determine and/or assure compliance with any such standards and related certifications as may be applicable. You will employ reasonable safeguards to ensure that your use of the EVM will not result in any property damage, injury or death, even if the EVM should fail to perform as described or expected.
4. You will take care of proper disposal and recycling of the EVM's electronic components and packing materials.

Certain Instructions. It is important to operate this EVM within TI's recommended specifications and environmental considerations per the user guidelines. Exceeding the specified EVM ratings (including but not limited to input and output voltage, current, power, and environmental ranges) may cause property damage, personal injury or death. If there are questions concerning these ratings please contact a TI field representative prior to connecting interface electronics including input power and intended loads. Any loads applied outside of the specified output range may result in unintended and/or inaccurate operation and/or possible permanent damage to the EVM and/or interface electronics. Please consult the EVM User's Guide prior to connecting any load to the EVM output. If there is uncertainty as to the load specification, please contact a TI field representative. During normal operation, some circuit components may have case temperatures greater than 60°C as long as the input and output are maintained at a normal ambient operating temperature. These components include but are not limited to linear regulators, switching transistors, pass transistors, and current sense resistors which can be identified using the EVM schematic located in the EVM User's Guide. When placing measurement probes near these devices during normal operation, please be aware that these devices may be very warm to the touch. As with all electronic evaluation tools, only qualified personnel knowledgeable in electronic measurement and diagnostics normally found in development environments should use these EVMs.

Agreement to Defend, Indemnify and Hold Harmless. You agree to defend, indemnify and hold TI, its licensors and their representatives harmless from and against any and all claims, damages, losses, expenses, costs and liabilities (collectively, "Claims") arising out of or in connection with any use of the EVM that is not in accordance with the terms of the agreement. This obligation shall apply whether Claims arise under law of tort or contract or any other legal theory, and even if the EVM fails to perform as described or expected.

Safety-Critical or Life-Critical Applications. If you intend to evaluate the components for possible use in safety critical applications (such as life support) where a failure of the TI product would reasonably be expected to cause severe personal injury or death, such as devices which are classified as FDA Class III or similar classification, then you must specifically notify TI of such intent and enter into a separate Assurance and Indemnity Agreement.

IMPORTANT NOTICE

Texas Instruments Incorporated and its subsidiaries (TI) reserve the right to make corrections, enhancements, improvements and other changes to its semiconductor products and services per JESD46, latest issue, and to discontinue any product or service per JESD48, latest issue. Buyers should obtain the latest relevant information before placing orders and should verify that such information is current and complete. All semiconductor products (also referred to herein as "components") are sold subject to TI's terms and conditions of sale supplied at the time of order acknowledgment.

TI warrants performance of its components to the specifications applicable at the time of sale, in accordance with the warranty in TI's terms and conditions of sale of semiconductor products. Testing and other quality control techniques are used to the extent TI deems necessary to support this warranty. Except where mandated by applicable law, testing of all parameters of each component is not necessarily performed.

TI assumes no liability for applications assistance or the design of Buyers' products. Buyers are responsible for their products and applications using TI components. To minimize the risks associated with Buyers' products and applications, Buyers should provide adequate design and operating safeguards.

TI does not warrant or represent that any license, either express or implied, is granted under any patent right, copyright, mask work right, or other intellectual property right relating to any combination, machine, or process in which TI components or services are used. Information published by TI regarding third-party products or services does not constitute a license to use such products or services or a warranty or endorsement thereof. Use of such information may require a license from a third party under the patents or other intellectual property of the third party, or a license from TI under the patents or other intellectual property of TI.

Reproduction of significant portions of TI information in TI data books or data sheets is permissible only if reproduction is without alteration and is accompanied by all associated warranties, conditions, limitations, and notices. TI is not responsible or liable for such altered documentation. Information of third parties may be subject to additional restrictions.

Resale of TI components or services with statements different from or beyond the parameters stated by TI for that component or service voids all express and any implied warranties for the associated TI component or service and is an unfair and deceptive business practice. TI is not responsible or liable for any such statements.

Buyer acknowledges and agrees that it is solely responsible for compliance with all legal, regulatory and safety-related requirements concerning its products, and any use of TI components in its applications, notwithstanding any applications-related information or support that may be provided by TI. Buyer represents and agrees that it has all the necessary expertise to create and implement safeguards which anticipate dangerous consequences of failures, monitor failures and their consequences, lessen the likelihood of failures that might cause harm and take appropriate remedial actions. Buyer will fully indemnify TI and its representatives against any damages arising out of the use of any TI components in safety-critical applications.

In some cases, TI components may be promoted specifically to facilitate safety-related applications. With such components, TI's goal is to help enable customers to design and create their own end-product solutions that meet applicable functional safety standards and requirements. Nonetheless, such components are subject to these terms.

No TI components are authorized for use in FDA Class III (or similar life-critical medical equipment) unless authorized officers of the parties have executed a special agreement specifically governing such use.

Only those TI components which TI has specifically designated as military grade or "enhanced plastic" are designed and intended for use in military/aerospace applications or environments. Buyer acknowledges and agrees that any military or aerospace use of TI components which have **not** been so designated is solely at the Buyer's risk, and that Buyer is solely responsible for compliance with all legal and regulatory requirements in connection with such use.

TI has specifically designated certain components as meeting ISO/TS16949 requirements, mainly for automotive use. In any case of use of non-designated products, TI will not be responsible for any failure to meet ISO/TS16949.

Products

Audio	www.ti.com/audio
Amplifiers	amplifier.ti.com
Data Converters	dataconverter.ti.com
DLP® Products	www.dlp.com
DSP	dsp.ti.com
Clocks and Timers	www.ti.com/clocks
Interface	interface.ti.com
Logic	logic.ti.com
Power Mgmt	power.ti.com
Microcontrollers	microcontroller.ti.com
RFID	www.ti-rfid.com
OMAP Applications Processors	www.ti.com/omap
Wireless Connectivity	www.ti.com/wirelessconnectivity

Applications

Automotive and Transportation	www.ti.com/automotive
Communications and Telecom	www.ti.com/communications
Computers and Peripherals	www.ti.com/computers
Consumer Electronics	www.ti.com/consumer-apps
Energy and Lighting	www.ti.com/energy
Industrial	www.ti.com/industrial
Medical	www.ti.com/medical
Security	www.ti.com/security
Space, Avionics and Defense	www.ti.com/space-avionics-defense
Video and Imaging	www.ti.com/video

TI E2E Community

e2e.ti.com