

Evaluating the ADP195 High-Side Power Switch

FEATURES

Ultrasmall 1 mm × 1 mm, 4-ball, 0.5 mm pitch WLCSP

Small 2 mm × 2 mm, 6-lead, 0.5 mm pitch LFCSP

Low $R_{DS(on)}$ of 65 m Ω at 1.8 V

Low input voltage range of 1.1 V to 3.6 V

1 amp continuous operating current

Operating temperature range: $T_J = -40^{\circ}\text{C}$ to $+85^{\circ}\text{C}$

GENERAL DESCRIPTION

The ADP195-EVALZ and ACP195CP-EVALZ are used to demonstrate the functionality of the ADP195 power switch.

Simple device measurements such as VIN to VOUT resistance ($R_{DS(on)}$), ground current, and off state current can be demonstrated with just a single voltage supply, a voltmeter, a current meter, and load resistors.

Full details about the [ADP195](#) high side power switches are available in the ADP195 data sheet, which should be consulted when using the ADP195-EVALZ or ADP195CP-EVALZ.

EVALUATION BOARDS

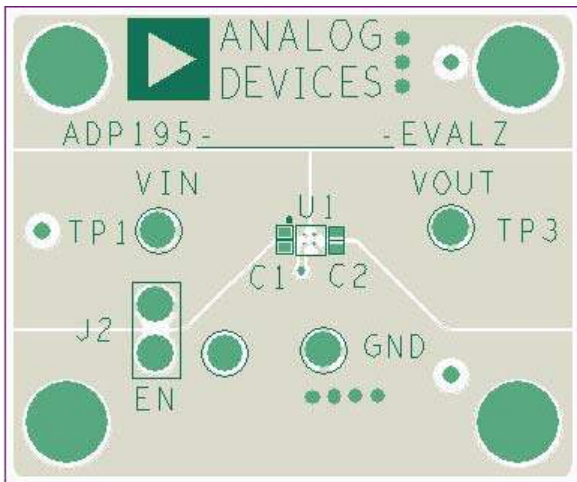

Figure 1. 4-Ball WLCSP Demonstration Evaluation Board

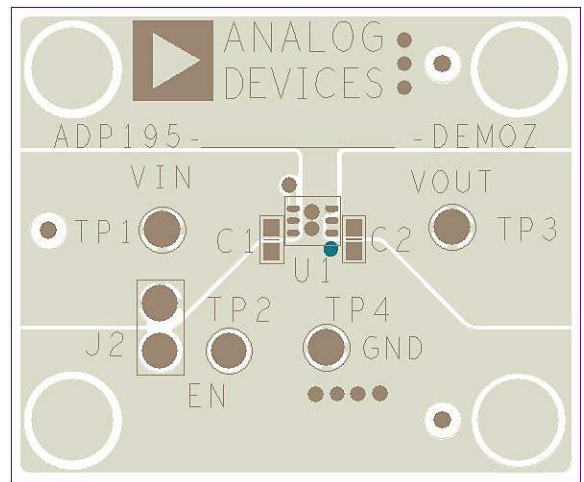

Figure 2. 6-Lead LFCSP Evaluation Board

TABLE OF CONTENTS

Features	1	Ground Current Measurement.....	6
General Description	1	Ground Current Consumption	7
Evaluation Boards.....	1	Shutdown Current Measurement.....	8
Revision History	2	Ordering Information.....	10
Evaluation Board Schematic and Hardware	3	Bill of Materials.....	10
V_{IN} to V_{OUT} Resistance ($R_{DS(ON)}$).....	4		

REVISION HISTORY

1/11—Rev. 0 to Rev. A

Changes to Features Section and General Description Section .	1
Added Figure 2; Renumbered Sequentially	1
Added Figure 4.....	3
Changes to V_{IN} and V_{OUT} Resistance ($R_{DS(ON)}$) Section	4
Added Figure 6.....	4
Added Figure 8.....	5
Changes to Ground Current Measurement Section	6
Added Figure 10.....	6
Changes to Shutdown Current Measurement Section	8
Added Figure 14.....	9
Changes to Table 2.....	10

4/10—Revision 0: Initial Version

EVALUATION BOARD SCHEMATIC AND HARDWARE

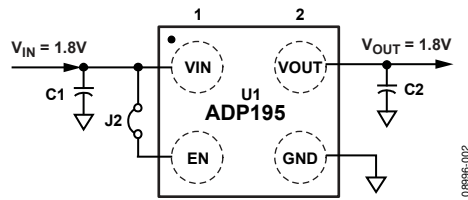

Figure 3. 4-Ball WLCSP Evaluation Board Schematic

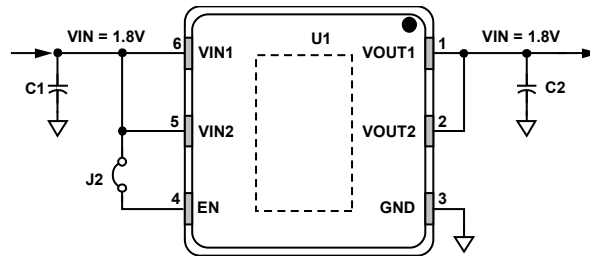

Figure 4. 6-Lead LFCSP Evaluation Board Schematic

Table 1. Evaluation Board Hardware Components

Component	Function	Description
U1	Power switch	High-side power switch.
C1	Input capacitor	0.1 μ F input bypass capacitor. Optional to improve transient performance. Connect C1 from VIN to GND for the WLCSP, and VIN1 and VIN2 to GND for the LFCSP
C2	Output capacitor	0.1 μ F output capacitor. Optional to improve transient performance. Connect C2 from VOUT to GND for the WLCSP, and VOUT1 and VOUT2 to GND for the LFCSP.
J2	Jumper	Jumper. Connects EN to VIN for the WLCSP, or VIN1 and VIN2 for the LFCSP to enable automatic startup.

V_{IN} TO V_{OUT} RESISTANCE (R_{DS(ON)})

R_{DS(ON)} can be measured using the configurations shown in Figure 7 and Figure 8. R_{DS(ON)} is defined as the input-to-output voltage differential divided by the load current.

The voltmeter reading divided by the load current value gives the equivalent R_{DS(ON)} value. For more accurate measurements, a second voltmeter can be used to monitor the input voltage across the input capacitor. The input supply voltage may need to be adjusted to account for IR drops, especially if large load currents are used. Figure 5 shows a typical curve of R_{DS(ON)} measurements with different load currents for the 4-ball WLCSP package and Figure 6 shows a typical curve of R_{DS(ON)} measurements with different load currents for the 6-lead LFCSP.

Use the following steps to connect to a voltage source and voltmeter:

1. Connect the negative terminal (-) of the voltage source to one of the GND pads on the evaluation board.
2. Connect the positive terminal (+) of the voltage source to the VIN pad of the evaluation board.
3. Connect a load between the VOUT pad and one of the GND pads.
4. Connect the negative terminal (-) of the voltmeter to the VOUT pad.
5. Connect the positive terminal (+) of the voltmeter to the VIN pad.

When these steps are completed, the voltage source can be turned on. If J1 is inserted (connecting EN to VIN for automatic startup), the switch powers up.

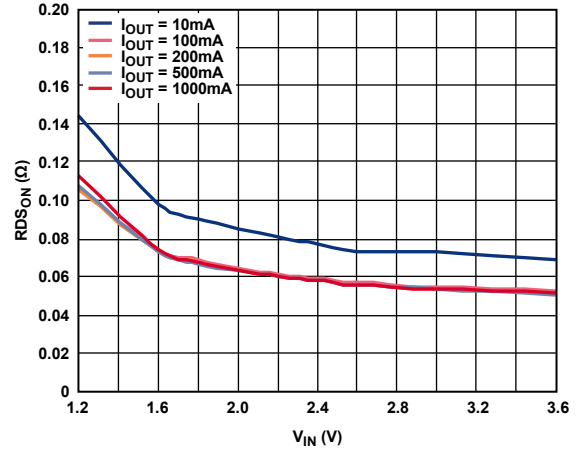

Figure 5. 4-Ball WLCSP R_{DS(ON)} vs. Input Voltage, V_{IN}

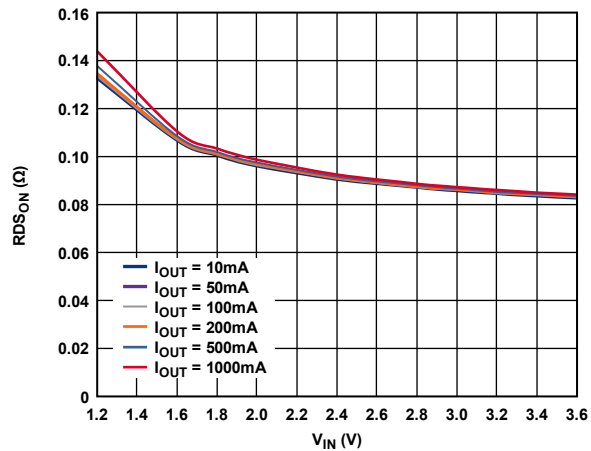

Figure 6. 6-Lead LFCSP R_{DS(ON)} vs. Input Voltage, V_{IN}

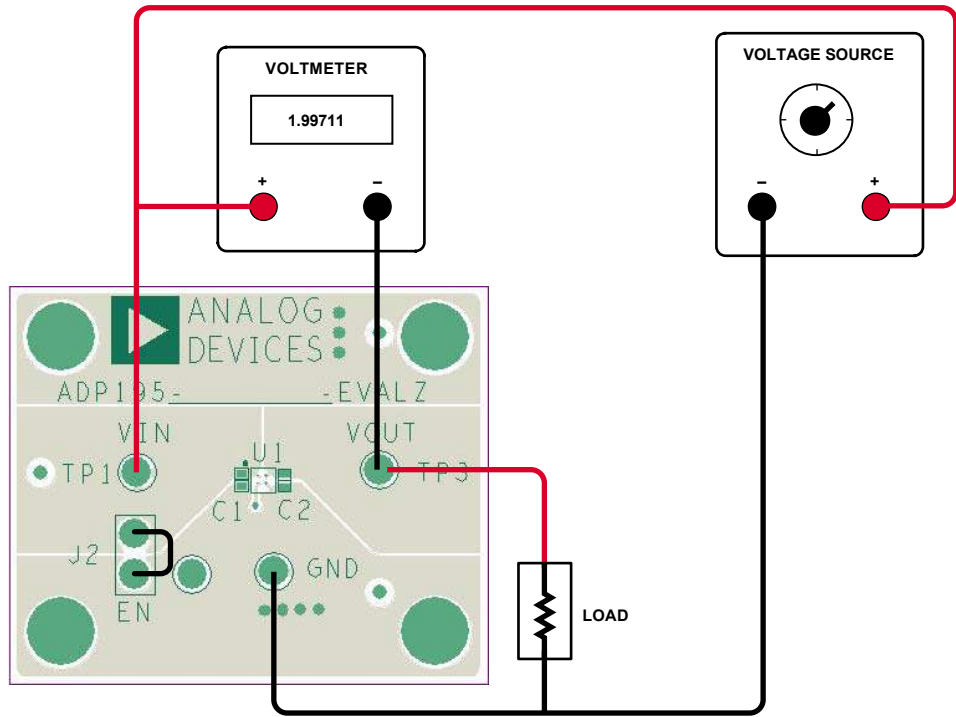

Figure 7. WLCSP $R_{DS(on)}$ Measurement

06996-004

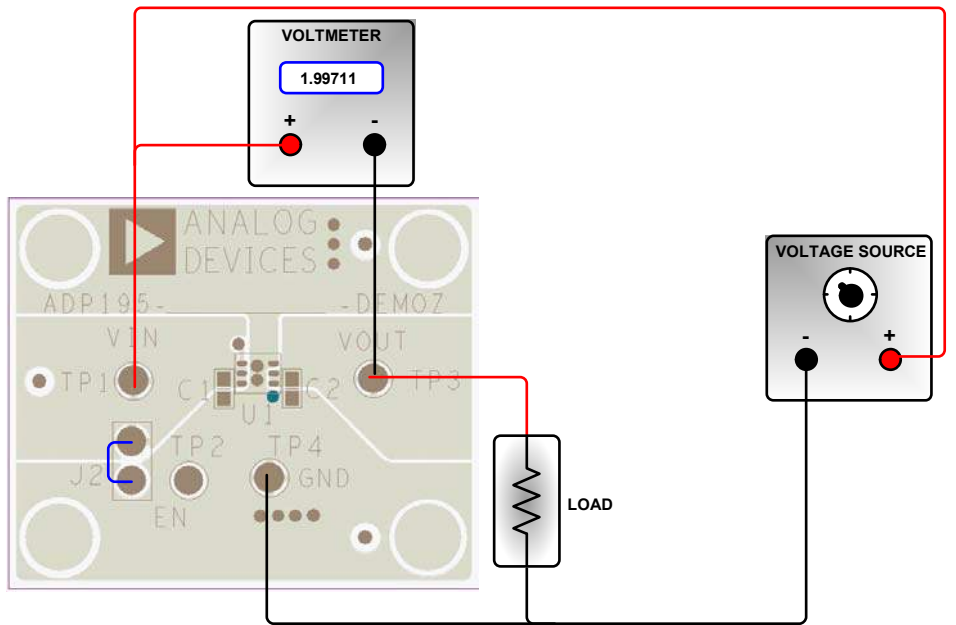

Figure 8. LFCSP $R_{DS(on)}$ Measurement

06996-009

GROUND CURRENT MEASUREMENT

Figure 9 and Figure 10 show how the evaluation boards can be connected to a voltage source and an ammeter for ground current measurements. A resistor can be used as the load for the regulator. Ensure that the resistor has a power rating adequate to handle the power expected to be dissipated across it. An electronic load can be used as an alternative. Ensure that the voltage source used can supply enough current for the expected load levels. If voltmeters are connected at the input or output terminals, subtract the current resulting from the shunt resistance of the voltmeter for accurate ground current measurement.

Follow these steps to connect to a voltage source and ammeter:

1. Connect the positive terminal (+) of the voltage source to the VIN pad on the evaluation board.
2. Connect the positive terminal (+) of the ammeter to the GND pad of the evaluation board.
3. Connect the negative terminal (-) of the ammeter to the negative (-) terminal of the voltage source.
4. Connect a load between the VOUT pad of the evaluation board and the negative (-) terminal of the voltage source.

The voltage source can now be turned on. If J2 is inserted (connecting EN to VIN for automatic startup), the switch powers up.

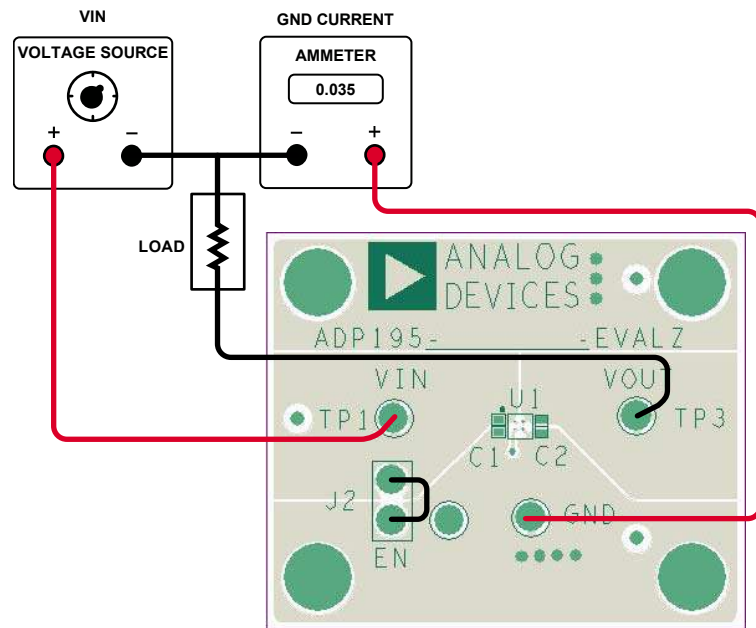

Figure 9. 4-Ball WLCSP Ground Current Measurement

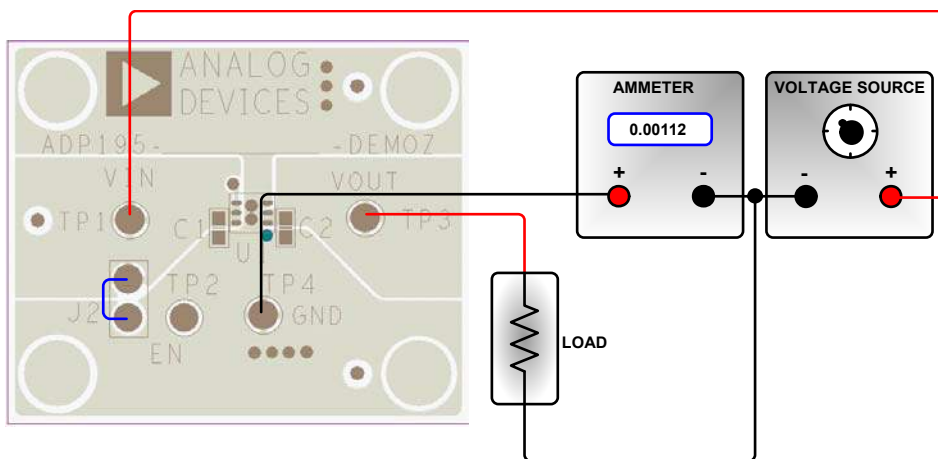

Figure 10. 6-Lead LFCSP Ground Current Measurement

GROUND CURRENT CONSUMPTION

Ground current measurement is a way of determining how much current the internal circuits of the regulator are consuming while performing the power switch function. To be efficient, the power switch must consume as little current as possible. Figure 11 shows the typical ground current consumption for various load levels.

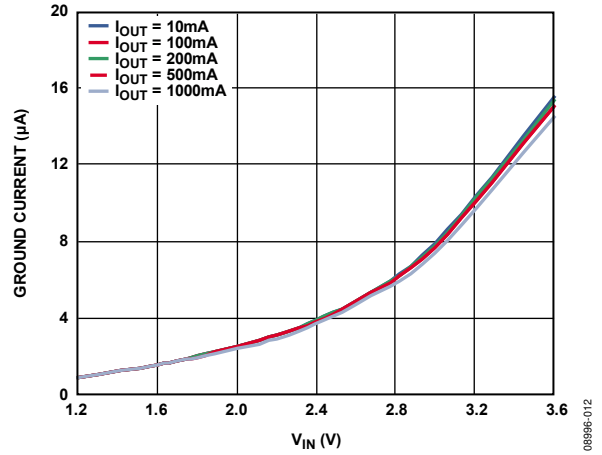

Figure 11. Ground Current vs. Input Voltage, V_{IN}

089P96-012

SHUTDOWN CURRENT MEASUREMENT

Figure 13 and Figure 14 show how the evaluation boards can be connected to a voltage source and an ammeter for shutdown current measurements. The ammeter can also be connected to the GND terminal to measure the ground current, which is equal to the shutdown current when EN is tied to ground. Figure 12 shows the typical shutdown current consumption for various input voltages.

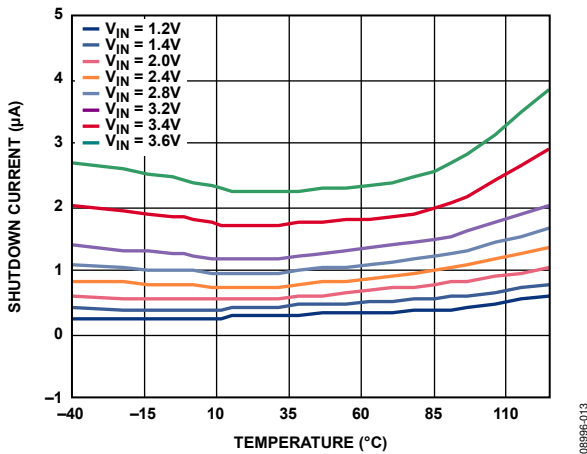

Figure 12. Shutdown Current vs. Temperature and Input Voltage, V_{IN}

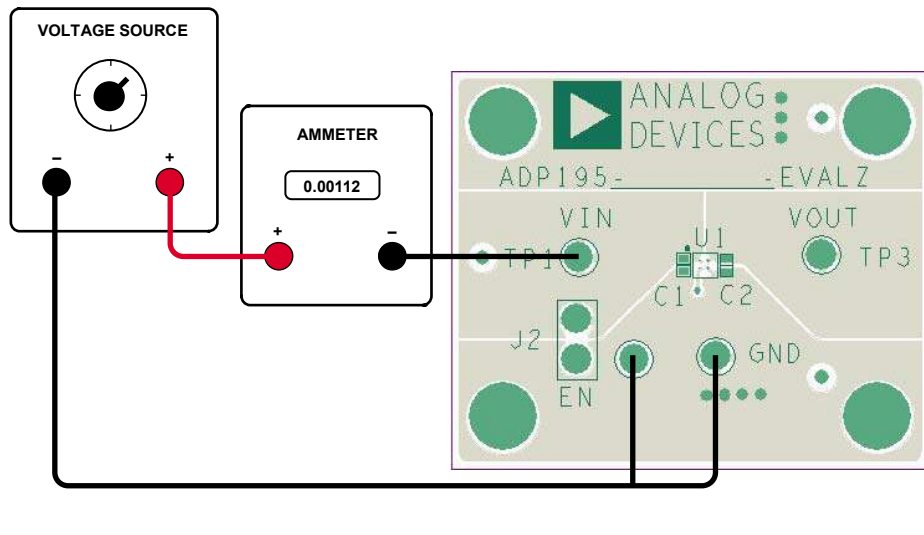

Figure 13. 4-Ball WLCSP Shutdown Current Measurement

Follow these steps to connect to a voltage source and ammeter:

1. Connect the positive terminal (+) of the voltage source to the (+) of the ammeter.
2. Connect the negative (-) terminal of the voltage source to GND pad and EN pin on the evaluation board.
3. Connect the negative terminal (-) of the ammeter to the VIN pad on the evaluation board.

The voltage source can now be turned on.

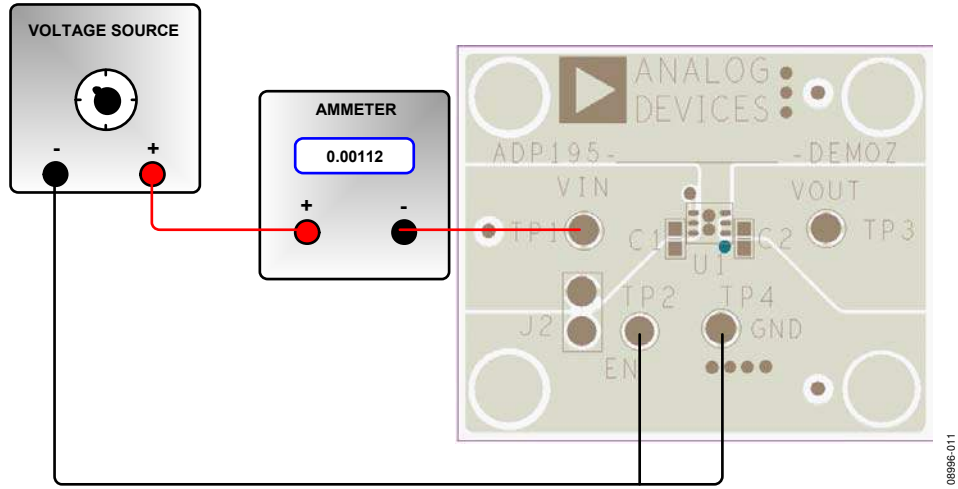

Figure 14. 6-Lead LFCSP Shutdown Current Measurement

08956-011

ORDERING INFORMATION**BILL OF MATERIALS**

Table 2.

Qty	Reference Designator	Description	Manufacturer/Vendor	Vendor Part No.
2	C1, C2	Capacitor, MLCC, 0.1 μ F, 10 V, 0402, X5R	Murata or equivalent	GRM155R61A104KA01D
1	J2	Header, single, STR, two pins	Digi-Key Corp.	S1012E-36-ND
1	U1	IC, power switch	Analog Devices, Inc.	ADP195ACBZ, ADP195ACPZ

NOTES

NOTES

**ESD Caution**

ESD (electrostatic discharge) sensitive device. Charged devices and circuit boards can discharge without detection. Although this product features patented or proprietary protection circuitry, damage may occur on devices subjected to high energy ESD. Therefore, proper ESD precautions should be taken to avoid performance degradation or loss of functionality.

Legal Terms and Conditions

By using the evaluation board discussed herein (together with any tools, components documentation or support materials, the "Evaluation Board"), you are agreeing to be bound by the terms and conditions set forth below ("Agreement") unless you have purchased the Evaluation Board, in which case the Analog Devices Standard Terms and Conditions of Sale shall govern. Do not use the Evaluation Board until you have read and agreed to the Agreement. Your use of the Evaluation Board shall signify your acceptance of the Agreement. This Agreement is made by and between you ("Customer") and Analog Devices, Inc. ("ADI"), with its principal place of business at One Technology Way, Norwood, MA 02062, USA. Subject to the terms and conditions of the Agreement, ADI hereby grants to Customer a free, limited, personal, temporary, non-exclusive, non-sublicensable, non-transferable license to use the Evaluation Board FOR EVALUATION PURPOSES ONLY. Customer understands and agrees that the Evaluation Board is provided for the sole and exclusive purpose referenced above, and agrees not to use the Evaluation Board for any other purpose. Furthermore, the license granted is expressly made subject to the following additional limitations: Customer shall not (i) rent, lease, display, sell, transfer, assign, sublicense, or distribute the Evaluation Board; and (ii) permit any Third Party to access the Evaluation Board. As used herein, the term "Third Party" includes any entity other than ADI, Customer, their employees, affiliates and in-house consultants. The Evaluation Board is NOT sold to Customer; all rights not expressly granted herein, including ownership of the Evaluation Board, are reserved by ADI. CONFIDENTIALITY. This Agreement and the Evaluation Board shall all be considered the confidential and proprietary information of ADI. Customer may not disclose or transfer any portion of the Evaluation Board to any other party for any reason. Upon discontinuation of use of the Evaluation Board or termination of this Agreement, Customer agrees to promptly return the Evaluation Board to ADI. ADDITIONAL RESTRICTIONS. Customer may not disassemble, decompile or reverse engineer chips on the Evaluation Board. Customer shall inform ADI of any occurred damages or any modifications or alterations it makes to the Evaluation Board, including but not limited to soldering or any other activity that affects the material content of the Evaluation Board. Modifications to the Evaluation Board must comply with applicable law, including but not limited to the RoHS Directive. TERMINATION. ADI may terminate this Agreement at any time upon giving written notice to Customer. Customer agrees to return to ADI the Evaluation Board at that time. LIMITATION OF LIABILITY. THE EVALUATION BOARD PROVIDED HEREUNDER IS PROVIDED "AS IS" AND ADI MAKES NO WARRANTIES OR REPRESENTATIONS OF ANY KIND WITH RESPECT TO IT. ADI SPECIFICALLY DISCLAIMS ANY REPRESENTATIONS, ENDORSEMENTS, GUARANTEES, OR WARRANTIES, EXPRESS OR IMPLIED, RELATED TO THE EVALUATION BOARD INCLUDING, BUT NOT LIMITED TO, THE IMPLIED WARRANTY OF MERCHANTABILITY, TITLE, FITNESS FOR A PARTICULAR PURPOSE OR NON-INFRINGEMENT OF INTELLECTUAL PROPERTY RIGHTS. IN NO EVENT WILL ADI AND ITS LICENSORS BE LIABLE FOR ANY INCIDENTAL, SPECIAL, INDIRECT, OR CONSEQUENTIAL DAMAGES RESULTING FROM CUSTOMER'S POSSESSION OR USE OF THE EVALUATION BOARD, INCLUDING BUT NOT LIMITED TO LOST PROFITS, DELAY COSTS, LABOR COSTS OR LOSS OF GOODWILL. ADI'S TOTAL LIABILITY FROM ANY AND ALL CAUSES SHALL BE LIMITED TO THE AMOUNT OF ONE HUNDRED US DOLLARS (\$100.00). EXPORT. Customer agrees that it will not directly or indirectly export the Evaluation Board to another country, and that it will comply with all applicable United States federal laws and regulations relating to exports. GOVERNING LAW. This Agreement shall be governed by and construed in accordance with the substantive laws of the Commonwealth of Massachusetts (excluding conflict of law rules). Any legal action regarding this Agreement will be heard in the state or federal courts having jurisdiction in Suffolk County, Massachusetts, and Customer hereby submits to the personal jurisdiction and venue of such courts. The United Nations Convention on Contracts for the International Sale of Goods shall not apply to this Agreement and is expressly disclaimed.