

REV.	ECR/ECN No.	DESCRIPTION	DRAWN/DATE	CHECKED/DATE	APPROVED/DATE
F		UPDATE FRAME	Staven 2020-11-13	Staven 2020-11-13	Biao 2020-11-13
G	ECN2022112	UPDATE CPK SYMBOLS	Abner 2022-07-20	Staven 2022-07-20	Sam 2022-07-20

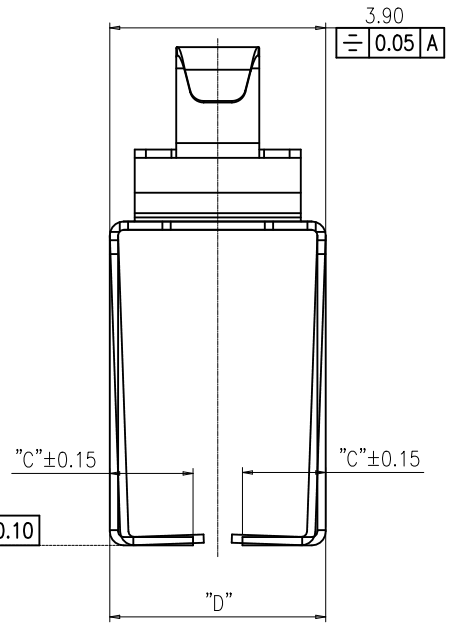
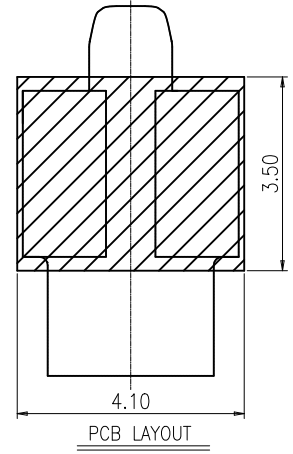
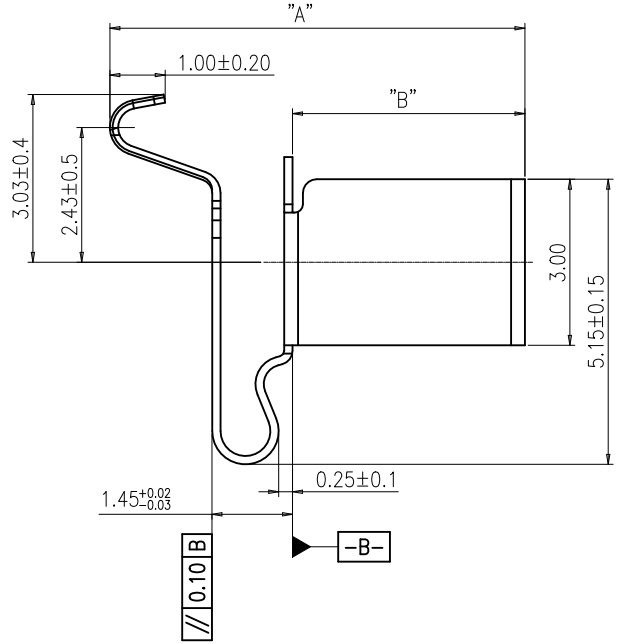
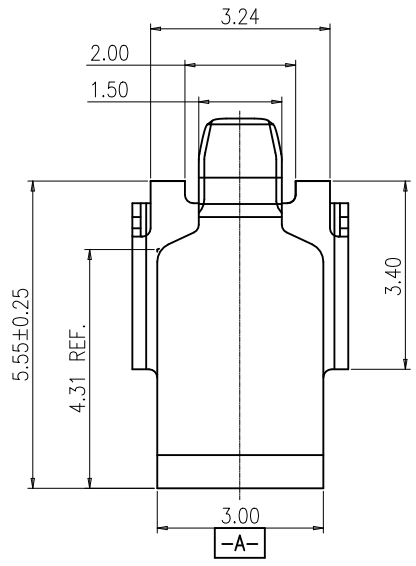

- NOTES:
- 1、 MATERIAL: SUS 304-H T=0.15mm;
  - 2、 ALLOW BURR 0.03mm Max.;
  - 3、 PLATING: Au 2u" SURFACE PLATING OVER CONTACT AREAS, Au 2u" SURFACE PLATING OVER SOLDER AREAS, Ni 40-120u" UNDER PLATING OVER ALL.
  - 4、 "▼" THE SYMBOL IS REPRESENTED AS CPK AND  $\bar{X}$ -R.

TABLE:

PART NUMBER	A	B	C	D
Z00D-4G7L1-11000	4.8 <sup>+0.3</sup> <sub>-0.05</sub>	1.5 <sup>+0.0</sup> <sub>-0.3</sub>	1.50	3.90 <sup>+0</sup> <sub>-0.20</sub>
Z007-4G7L1-11000	5.2 <sup>+0.3</sup> <sub>-0.05</sub>	1.9 <sup>+0.0</sup> <sub>-0.3</sub>	1.05	3.90 <sup>+0</sup> <sub>-0.20</sub>
Z00C-4G7L1-11000	7.5 <sup>+0.3</sup> <sub>-0.05</sub>	4.2 <sup>+0.0</sup> <sub>-0.3</sub>	1.50	3.90 <sup>+0</sup> <sub>-0.20</sub>
Z00F-4G7L1-11000	9.0 <sup>+0.3</sup> <sub>-0.05</sub>	5.7 <sup>+0.0</sup> <sub>-0.3</sub>	0.80	3.90 <sup>+0</sup> <sub>-0.5</sub>
Z00N-4G7L1-11000	6.3 <sup>+0.3</sup> <sub>-0.3</sub>	3.0±0.15	1.50	3.90±0.15
Z00E-4G7L1-11000	4.0 <sup>+0.3</sup> <sub>-0.3</sub>	0.7±0.15	1.50	3.90±0.15
Z00X-4G7L1-11000-E000	5.6 <sup>+0.3</sup> <sub>-0.3</sub>	2.3±0.15	1.50	3.90±0.15

UNLESS OTHERWISE SPECIFIED TOLERANCES		ANGLE OF PROJECTION		 Amphenol Aorora Technology (Huizhou) Co.,Ltd					
X.	±0.30	X. *	± 5'						
X.X	±0.25	X.X *	± 4'	DOC TYP	Customer Drw		TITLE:	SPRING	
X.XX	±0.20	X.XX *	± 3'	DRAWN	Abner	DATE	2022-07-20	SIZE	A4
X.XXX	±0.15	X.XXX *	± 2'	DESIGN	Abner	DATE	2022-07-20	PART NUMBER:	SEE TABLE
LINEAR DIMS		ANGLES DIMS		CHECKED	Staven	DATE	2022-07-20	REV.	G
DWG NO.: A-S0198				APPROVED	Sam	DATE	2022-07-20	SCALE	1:1
MATERIAL	SEE NOTES					UNIT	mm	SHEET	1 OF 1
FINISHED	SEE NOTES								



This document is the property of and embodies CONFIDENTIAL and PROPRIETARY information of AOR. No part of the information shown on this document may be used in any way or disclosed to others without the written consent of AOR. © 2019 AOR

1:PACKING INTO REEL

PULL OUT DIRECTION

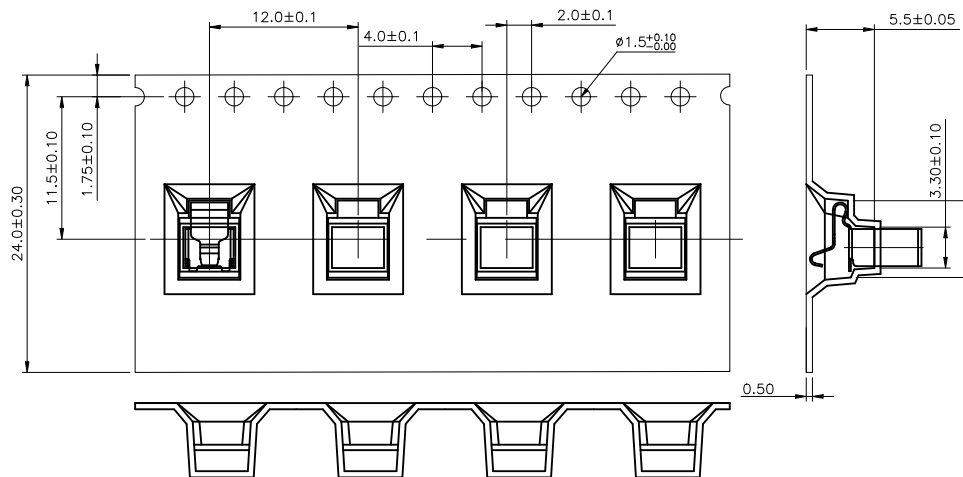

REV.	ECR/ECN No.	DESCRIPTION	DRAWN/DATE	CHECKED/DATE	APPROVED/DATE
D	ECN2022112	UPDATE FRAME	Abner 2022-07-20	Staven 2022-07-20	Sam 2022-07-20

TABLE:

PART NO.	PCS/REEL	N REEL/BOX (TOL PCS)
Z007-4G7L1-11000	900	10REEL/BOX (9000pcs)
Z01P-4G7L1-11000-E000		

2:PACKING INTO OUTER BOX

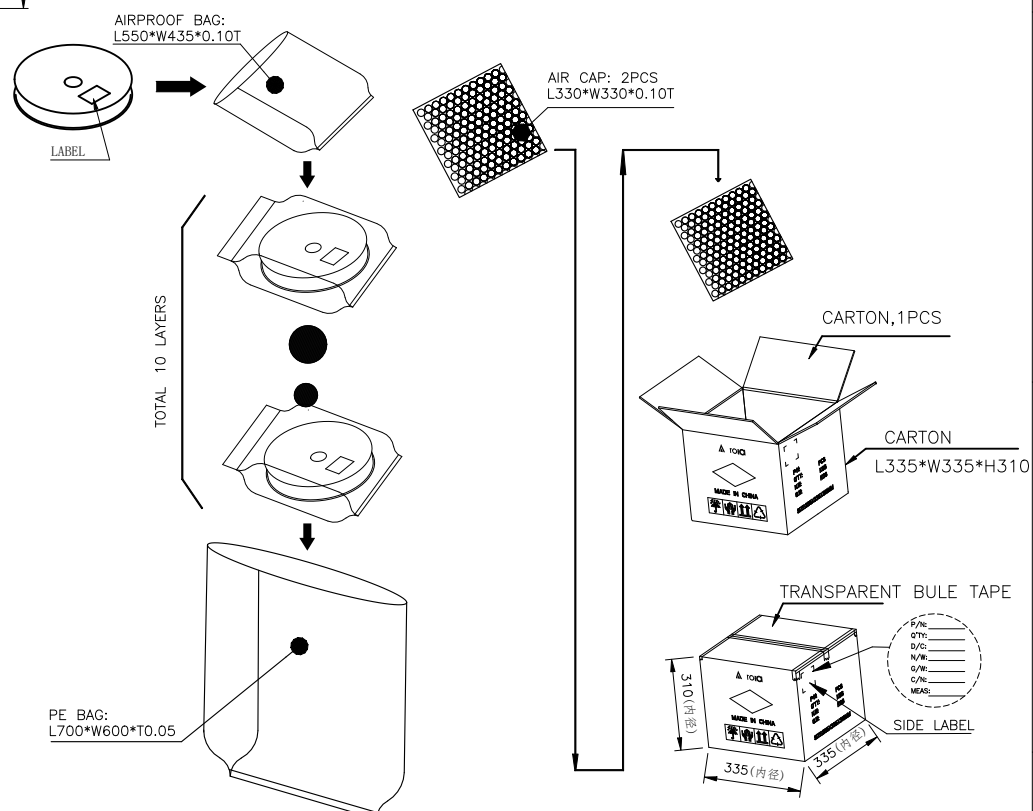

A

B

C

D



This document is the property of and embodies CONFIDENTIAL and PROPRIETARY information of AOR. No part of the information shown on this document may be used in any way or disclosed to others without the written consent of AOR. © 2019 AOR

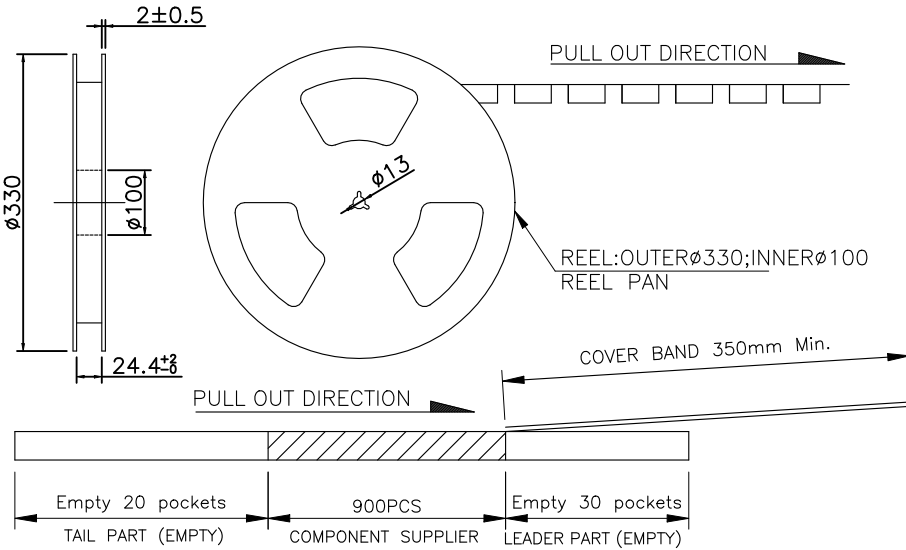

NOTES:

- MATERIAL:
  - CARRY TAPE:HIPS,T=0.50mm,CLEAR
  - REEL:HIPS,BLUE.
  - SHIM:PE,CLEAR.
- PRIMARY PACKING:900PCS/REEL.
- SECONDARY PACKING:10 REELS/CARTON ("TOTAL"=10\*900/CARTON).
- PEELING RESISTANCE: 0.1N~0.7N(10~70gf);  
PEELING ANGLE: 165°~180°;  
PEELING SPEED: 300mm/minutes.

UNLESS OTHERWISE SPECIFIED TOLERANCES			ANGLE OF PROJECTION	
X.	±0.15	X. *	± 1'	
X.X	±0.10	X.X *	± 0.5'	
X.XX	±0.05	X.XX *	± 0.5'	
X.XXX	±0.03	X.XXX *	± .1'	
LINEAR DIMS		ANGLES DIMS		
DWG NO.: A-H0108				
MATERIAL		SEE NOTES		
FINISHED		SEE NOTES		

DOG TYP		PACKING DWG.	
DRAWN	DATE	Abner	2022-07-20
DESIGN	DATE	Abner	2022-07-20
CHECKED	DATE	Staven	2022-07-20
APPROVED	DATE	Sam	2022-07-20

Amphenol AORORA				
Amphenol Aorora Technology (Huizhou) Co.,Ltd				
TITLE: SPRING H5.2				
SIZE	PART NUMBER:			REV.
A4	SEE TABLE			D
SCALE	1:1	UNIT : mm	SHEET 1 OF 1	