

PRELIMINARY

December 1989

Real Time Express™ Microcontroller

Features

- Fast 100ns Machine Cycle
- Single Cycle Instruction Execution
- Fast Step Arithmetic Operations
 - ▶ 20 Cycle Multiply
 - ▶ 21 Cycle Divide
 - ▶ 25 Cycle Square Root
- Direct Execution of Forth Language
 - ▶ Eliminates Assembly Language Programming
- Single Cycle Subroutine Call/Return
- Four Cycle Interrupt Latency
- On-Chip Interrupt Controller
- Three On-Chip 16-Bit Timer/Counters
- ASIC Bus™ for Off-Chip Extension of Architecture
- 1 Megabyte Total Address Space
- Word and Byte Memory Access
- Low Power CMOS.....5mA/MHz Typical
- Fully Static DC to 10MHz Operation
- 84-Pin PGA or PLCC Package
- Available in the Harris Standard Cell Library
- Pin Compatible to the RTX 2000™
 - ▶ Two On-Chip 64 Word Stacks

Description

The RTX 2001A is a 16-bit microcontroller which is particularly well suited for very high speed control tasks which are less arithmetically intensive than those tasks which require the full capabilities of the RTX 2000. In these application areas, this product offers cost/performance advantages, surpassing competing 8- and 16-bit microcontrollers by up to 50X.

Pin compatible to the RTX 2000, this processor incorporates two 64-word stacks with most of the features provided on the RTX 2000, including on-chip timers and an enhanced Interrupt Controller. Instruction execution times of one or two machine cycles are achieved by utilizing a stack oriented, multiple bus architecture. The high performance ASIC Bus, which is unique to the RTX™ family of products, provides for extension of the microcontroller architecture using off-chip hardware acceleration logic and application specific I/O devices. RTX Microcontrollers support high level languages such as Forth and C. The advantages of this product are further enhanced through the use of the peripherals and development system support Harris provides for the RTX family.

Combined, these features make the RTX 2001A an extremely powerful processor, providing the ability to meet numerous applications in low cost, high performance systems.

Applications

Embedded control; DMA controllers; stepper motor control; closed loop digital control and digital filter applications of moderate speed.

The RTX 2001A has been designed and fabricated utilizing the Harris Advanced Standard Cell and Compiler Library. As part of the Harris family of compatible cell libraries, the RTX 2001A architecture can also be incorporated into customer ASIC designs.

RTX 2001A Block Diagram

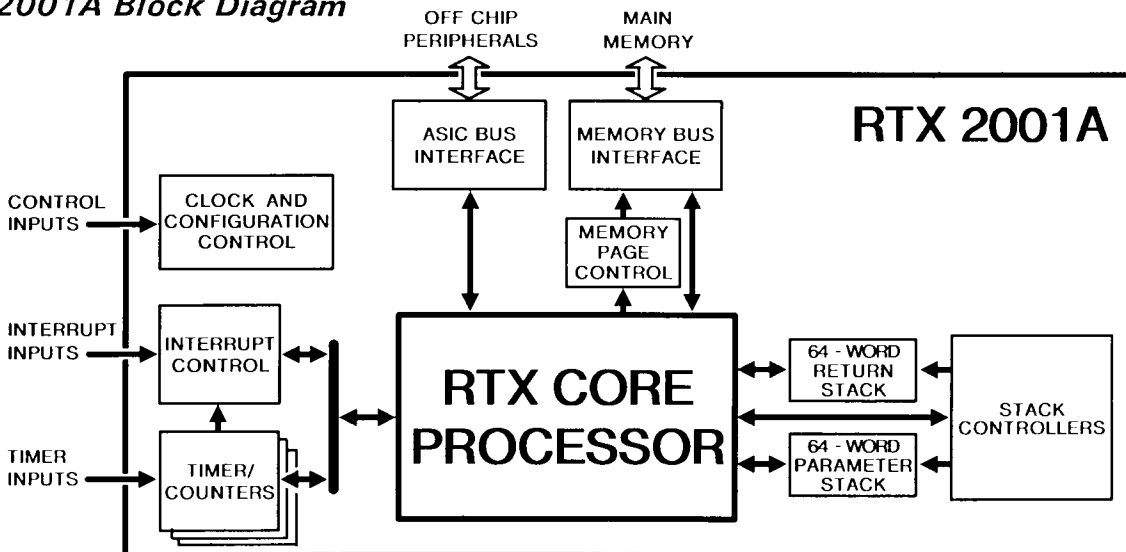

RTX™, RTX 2000™, RTX 2001A™, Real Time Express™, and ASIC Bus™ are Trademarks of Harris Corporation.

RTX 2001A

Pinouts

84 PIN PGA PACKAGE

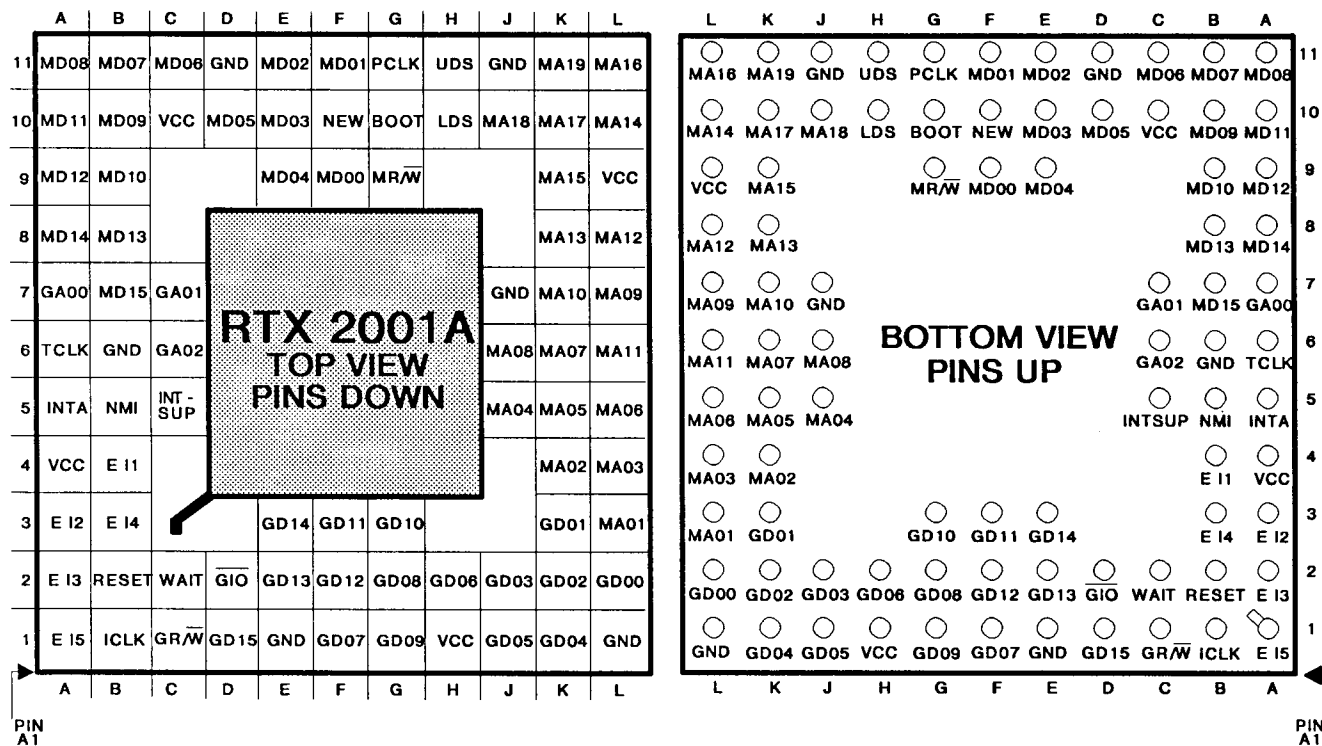

84 LEAD PLCC PACKAGE

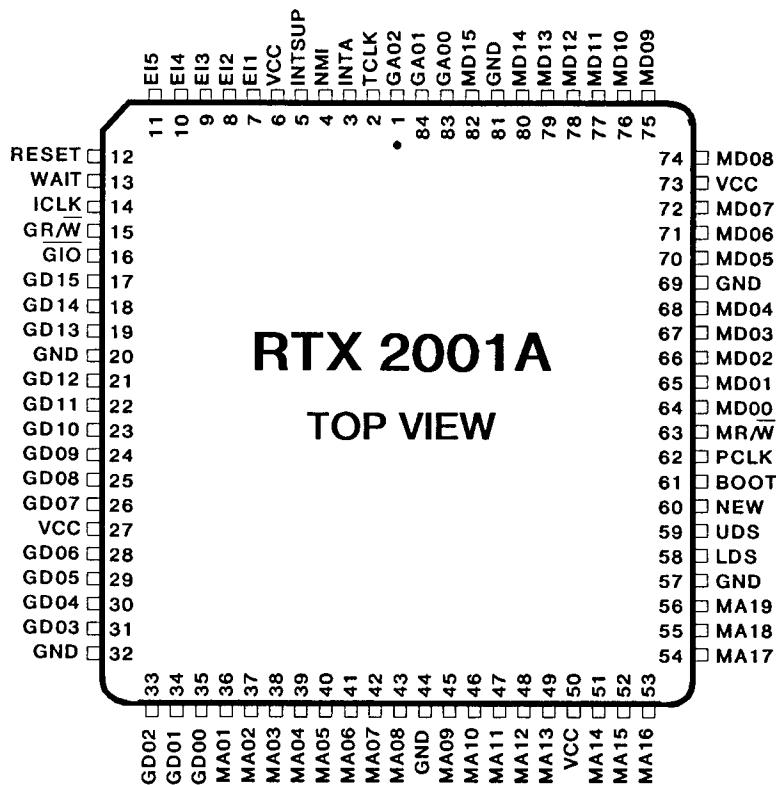

NOTE: An overbar on a signal name represents an active LOW signal.

TABLE 1. PGA AND PLCC PIN/SIGNAL ASSIGNMENTS

PLCC LEAD	PGA PIN	SIGNAL NAME	TYPE	PLCC LEAD	PGA PIN	SIGNAL NAME	TYPE
1	C6	GA02	Output; Address Bus	43	J6	MA08	Output; Address Bus
2	A6	TCLK	Output	44	J7	GND	Ground
3	A5	INTA	Output	45	L7	MA09	Output; Address Bus
4	B5	NMI	Input	46	K7	MA10	Output; Address Bus
5	C5	INTSUP	Input	47	L6	MA11	Output; Address Bus
6	A4	VCC	Power	48	L8	MA12	Output; Address Bus
7	B4	EI1	Input	49	K8	MA13	Output; Address Bus
8	A3	EI2	Input	50	L9	VCC	Power
9	A2	EI3	Input	51	L10	MA14	Output; Address Bus
10	B3	EI4	Input	52	K9	MA15	Output; Address Bus
11	A1	EI5	Input	53	L11	MA16	Output; Address Bus
12	B2	RESET	Input	54	K10	MA17	Output; Address Bus
13	C2	WAIT	Input	55	J10	MA18	Output; Address Bus
14	B1	ICLK	Input	56	K11	MA19	Output; Address Bus
15	C1	GR/W	Output	57	J11	GND	Ground
16	D2	GI \bar{O}	Output	58	H10	LDS	Output
17	D1	GD15	I/O; Data Bus	59	H11	UDS	Output
18	E3	GD14	I/O; Data Bus	60	F10	NEW	Output
19	E2	GD13	I/O; Data Bus	61	G10	BOOT	Output
20	E1	GND	Ground	62	G11	PCLK	Output
21	F2	GD12	I/O; Data Bus	63	G9	MR/W	Output
22	F3	GD11	I/O; Data Bus	64	F9	MD00	I/O; Data Bus
23	G3	GD10	I/O; Data Bus	65	F11	MD01	I/O; Data Bus
24	G1	GD09	I/O; Data Bus	66	E11	MD02	I/O; Data Bus
25	G2	GD08	I/O; Data Bus	67	E10	MD03	I/O; Data Bus
26	F1	GD07	I/O; Data Bus	68	E9	MD04	I/O; Data Bus
27	H1	VCC	Power	69	D11	GND	Ground
28	H2	GD06	I/O; Data Bus	70	D10	MD05	I/O; Data Bus
29	J1	GD05	I/O; Data Bus	71	C11	MD06	I/O; Data Bus
30	K1	GD04	I/O; Data Bus	72	B11	MD07	I/O; Data Bus
31	J2	GD03	I/O; Data Bus	73	C10	VCC	Power
32	L1	GND	Ground	74	A11	MD08	I/O; Data Bus
33	K2	GD02	I/O; Data Bus	75	B10	MD09	I/O; Data Bus
34	K3	GD01	I/O; Data Bus	76	B9	MD10	I/O; Data Bus
35	L2	GD00	I/O; Data Bus	77	A10	MD11	I/O; Data Bus
36	L3	MA01	Output; Address Bus	78	A9	MD12	I/O; Data Bus
37	K4	MA02	Output; Address Bus	79	B8	MD13	I/O; Data Bus
38	L4	MA03	Output; Address Bus	80	A8	MD14	I/O; Data Bus
39	J5	MA04	Output; Address Bus	81	B6	GND	Ground
40	K5	MA05	Output; Address Bus	82	B7	MD15	I/O; Data Bus
41	L5	MA06	Output; Address Bus	83	A7	GA00	Output; Address Bus
42	K6	MA07	Output; Address Bus	84	C7	GA01	Output; Address Bus

TABLE 2. OUTPUT SIGNAL DESCRIPTIONS

SIGNAL	PLCC LEAD	RESET LEVEL	DESCRIPTION
OUTPUTS			
NEW	60	1	NEW: A HIGH on this pin indicates that an Instruction Fetch is in progress.
BOOT	61	1	BOOT: A HIGH on this pin indicates that Boot Memory is being accessed. This pin can be set or reset by accessing bit 3 of the Configuration Register.
MR/W	63	1	MEMORY READ/WRITE: A LOW on this pin indicates that a Memory Write operation is in progress.
UDS	59	1	UPPER DATA SELECT: A HIGH on this pin indicates that the high byte of memory (MD15-MD08) is being accessed.
LDS	58	1	LOWER DATA SELECT: A HIGH on this pin indicates that the low byte of memory (MD07-MD00) is being accessed.
GI \bar{O}	16	1	ASIC I/O: A LOW on this pin indicates that an ASIC Bus operation is in progress.
GR/W	15	1	ASIC READ/WRITE: A LOW on this pin indicates that an ASIC Bus Write operation is in progress.
PCLK	62	0	PROCESSOR CLOCK: Runs at half the frequency of ICLK. All processor cycles begin on the rising edge of PCLK. Held low extra cycles when WAIT is asserted.
TCLK	2	0	TIMING CLOCK: Same frequency and phase as PCLK but continues running during Wait cycles.
INTA	3	0	INTERRUPT ACKNOWLEDGE: A HIGH on this pin indicates that an Interrupt Acknowledge cycle is in progress.

TABLE 3. INPUT SIGNAL, BUS, AND POWER CONNECTION DESCRIPTIONS

SIGNAL	PLCC LEAD	DESCRIPTION
INPUTS		
WAIT	13	WAIT: A HIGH on this pin causes PCLK to be held LOW and the current cycle to be extended.
ICLK	14	INPUT CLOCK: Internally divided by 2 to generate all on-chip timing (Schmitt trigger CMOS input levels).
RESET	12	A HIGH level on this pin resets the RTX. Must be held high for at least 4 ICLK cycles (Schmitt trigger CMOS input levels).
EI2, EI1	8, 7	EXTERNAL INTERRUPTS 2, 1: Active HIGH level-sensitive inputs to the Interrupt Controller. Sampled on the rising edge of PCLK. See Timing Diagrams for detail.
EI5-EI3	11-9	EXTERNAL INTERRUPTS 5, 4, 3: Dual purpose inputs; active HIGH level-sensitive Interrupt Controller inputs; active HIGH edge-sensitive Timer/Counter inputs. As interrupt inputs, they are sampled on the rising edge of PCLK. See Timing Diagrams for detail.
NMI	4	NON-MASKABLE INTERRUPT: Active HIGH edge-sensitive Interrupt Controller input capable of interrupting any processor cycle. See the Interrupt Suppression Section (Schmitt trigger CMOS input levels).
INTSUP	5	INTERRUPT SUPPRESS: A HIGH on this pin inhibits all maskable interrupts, internal and external.
ADDRESS BUSES (OUTPUTS)		
GA02	1	ASIC ADDRESS: 3-bit ASIC Address Bus, which carries address information for external ASIC devices.
GA01	84	
GA00	83	
MA19-MA14	56-51	MEMORY ADDRESS: 19-bit Memory Address Bus, which carries address information for Main Memory.
MA13-MA09	49-45	
MA08-MA01	43-36	
DATA BUSES (I/O)		
GD15-GD13	17-19	ASIC DATA: 16-bit bidirectional external ASIC Data Bus, which carries data to and from off-chip I/O devices.
GD12-GD07	21-26	
GD06-GD03	28-31	
GD02-GD00	33-35	
MD15	82	MEMORY DATA: 16-bit bidirectional Memory Data Bus, which carries data to and from Main Memory.
MD14-MD08	80-74	
MD07-MD05	72-70	
MD04-MD00	68-64	
POWER CONNECTIONS		
VCC	6, 27, 50, 73	Power supply +5 Volt connections. A 0.1 μ F, low impedance decoupling capacitor should be placed between VCC and GND. This should be located as close to the RTX package as possible.
GND	20, 32, 44, 57, 69, 81	Power supply ground return connections.

RTX 2001A Microcontroller

The RTX 2001A is designed around the RTX Processor core, which is part of the Harris Standard Cell Library.

This processor core has eight 16-bit internal registers, an ALU, internal data buses, and control hardware to perform instruction decoding and sequencing.

On-chip peripherals which the RTX 2001A offers include a Memory Page Controller, an Interrupt Controller, three Timer/Counters, and two Stack Controllers. Two scratchpad registers, one of which can be used for automatic counting, are also provided on-chip in addition to the hardware registers which support the peripheral controllers.

Off-chip user interfaces provide address and data access to Main Memory and ASIC I/O devices, user defined interrupt signals, and Clock/Reset controls.

Figure 1 shows the data paths between the core, on-chip peripherals, and off-chip interfaces.

The RTX 2001A microcontroller is based on a two-stack architecture. These two stacks, which are Last-in-first-out (LIFO) memories, are called the Parameter Stack and the Return Stack.

Two internal registers, **TOP** and **NEXT**, provide the top two elements of the 16-bit wide Parameter Stack, while the remaining elements are contained in on-chip memory ("stack memory").

The top element of the Return Stack is 21 bits wide, and is stored in registers **I** and **IPR**, while the remaining elements are contained in stack memory.

The highly parallel architecture of the RTX is optimized for minimal Subroutine Call/Return overhead. As a result, a Subroutine Call takes one Cycle, while a Subroutine Return is usually incorporated into the preceding instruction and does not add any processor cycles. This parallelism provides for peak execution rates during simultaneous bus operations which can reach the equivalent of 40 million Forth language operations per second at a clock rate of 10MHz. Typical execution rates exceed 10 million operations per second.

Processor timing is driven by a 2X clock (ICLK) with a Schmitt trigger input. This allows use with systems which reduce power consumption by using a slow input clock with arbitrarily slow rise and fall times.

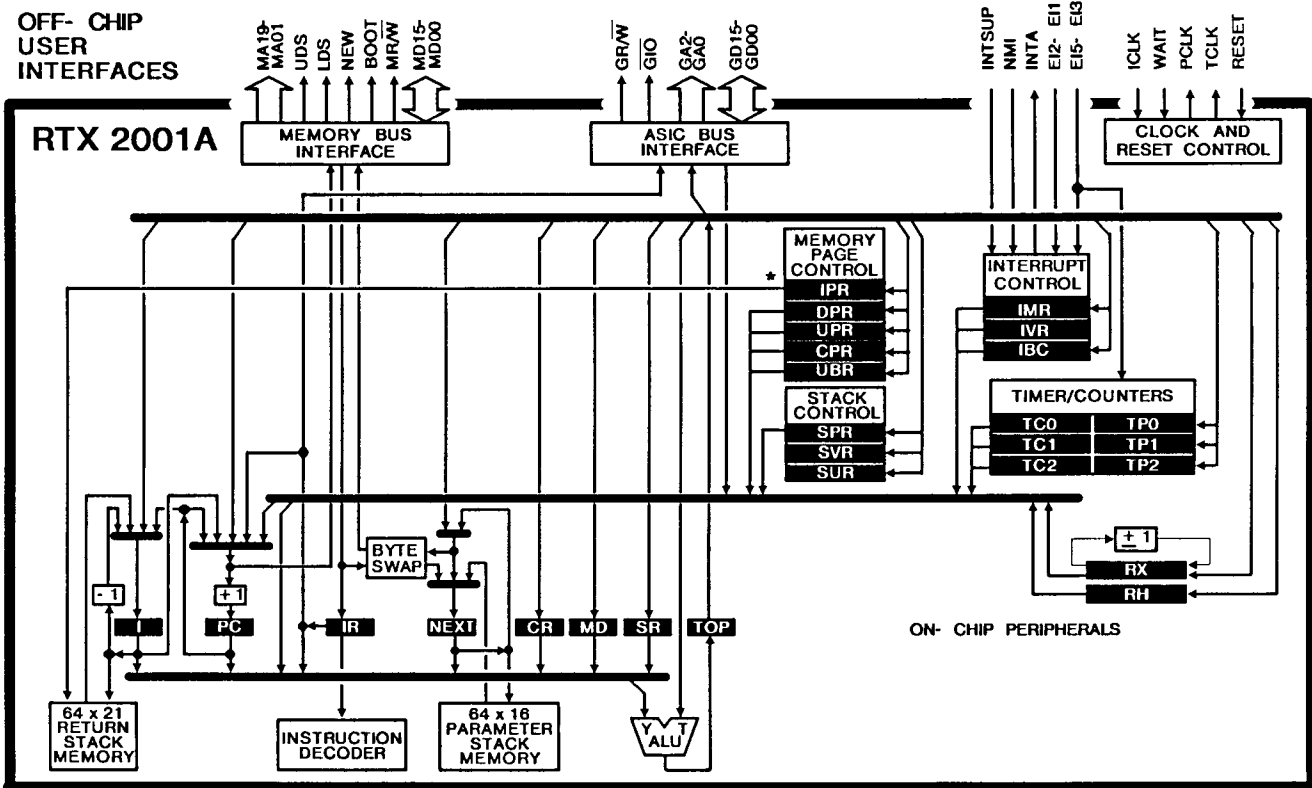

FIGURE 1. RTX 2001A FUNCTIONAL BLOCK DIAGRAM

* **IPR** contains the 5 most significant bits (20-16) of the top element of the Return Stack.

RTX 2001A Operation

Control of all data paths and the **Program Counter Register**, (**PC**), is provided by the Instruction Decoder. This hardware determines what function is to be performed by looking at the contents of the **Instruction Register**, (**IR**), and subsequently determines the sequence of operations through data path control.

Instructions which do not perform memory accesses execute in a single clock cycle while the next instruction is being fetched.

As shown in Figure 2, the instruction is latched into **IR** at the beginning of a clock cycle. The instruction is then decoded by the processor. All necessary internal operations are performed simultaneously with fetching the next instruction.

Instructions which access memory require two clock cycles to be executed. During the first cycle of a memory access instruction, the instruction is decoded, the address of the memory location to be accessed is placed on the Memory

Address Bus (**MA19-MA01**), and the memory data (**MD15-MD00**), is read or written. During the second cycle, ALU operations are performed, the address of the next instruction to be executed is placed on the Memory Address Bus, and the next instruction is fetched, as indicated in the bottom half of Figure 2.

RTX Data Buses and Address Buses

The RTX core bus architecture provides for unidirectional data paths and simultaneous operation of some data buses. This parallelism allows for maximum efficiency of data flow internal to the core.

Addresses for accessing external (off-chip) memory or ASIC devices are output via either the Memory Address Bus (**MA19-MA01**) or the ASIC Address Bus (**GA02-GA00**). See Table 3. External data is transferred by the ASIC Data Bus (**GD15-GD00**) and the Memory Data Bus (**MD15-MD00**), both of which are bidirectional.

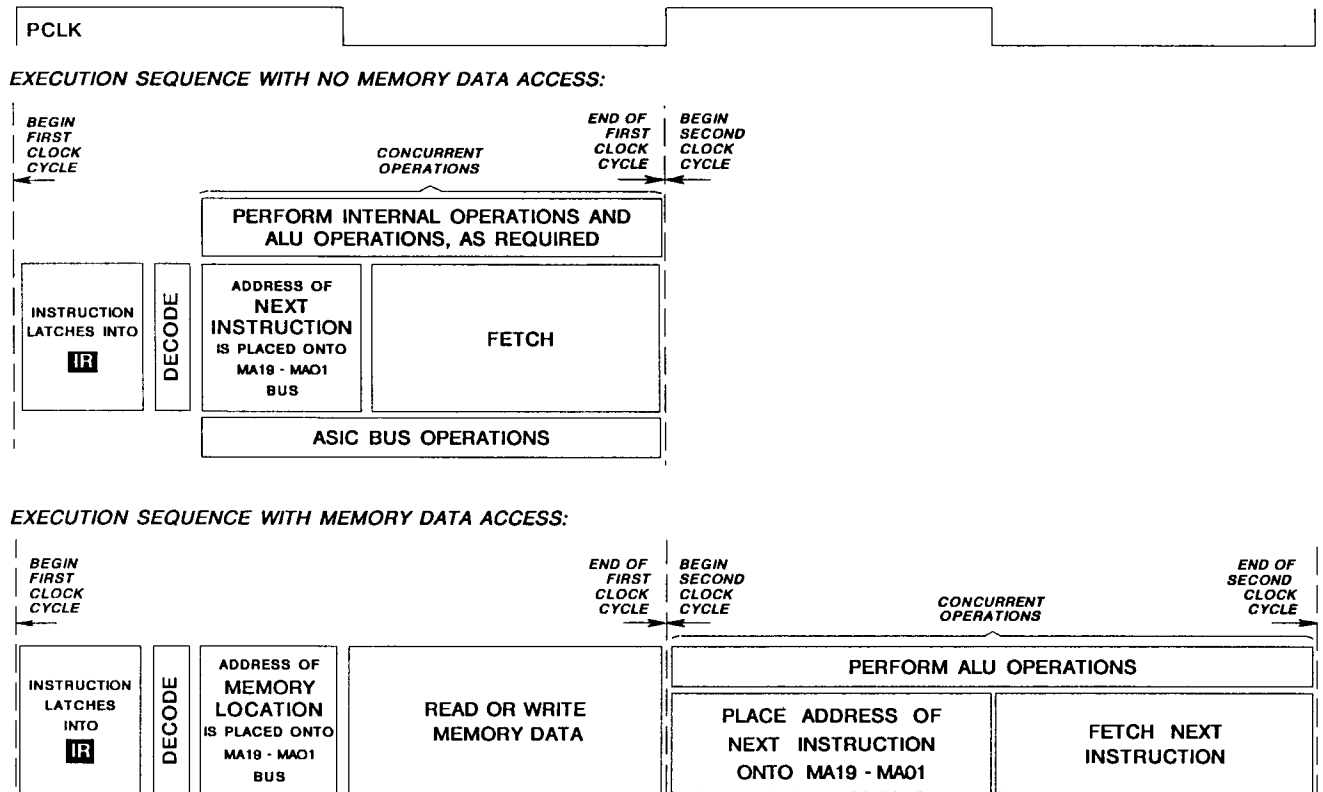

FIGURE 2. INSTRUCTION EXECUTION SEQUENCE

RTX Internal Registers

The core of the RTX 2001A is a macrocell available through the Harris Standard Cell Library. This core contains eight 16-bit internal registers, which may be accessed implicitly or explicitly, depending upon the register accessed and the function being performed.

TOP : The **Top Register** contains the top element of the Parameter Stack. **TOP** is the implicit data source or destination for certain instructions, and has no ASIC address assignment. The contents of this register may be directed to any I/O device or to any processor register except the **Instruction Register**. **TOP** is also the T input to the ALU. Input to **TOP** must come through the ALU. This register also holds the most significant 16 bits of 32-bit products and 32-bit dividends.

NEXT : The **Next Register** holds the second element of the Parameter Stack. **NEXT** is the implicit data source or destination for certain instructions, and has no ASIC address assignment. During a stack "push", the contents of **NEXT** are transferred to stack memory, and the contents of **TOP** are put into **NEXT**. This register is used to hold the least significant 16 bits of 32-bit products. Memory data is accessed through **NEXT**, as described in the Memory Access section of this document.

IR : The **Instruction Register** is actually a latch which contains the instruction currently being executed, and has no ASIC address assignment. In certain instructions, an operand can be embedded in the instruction code, making **IR** the implicit source for that operand (as in the case of short literals). Input to this register comes from Main Memory (see Tables 12-24 for code information).

CR : The **Configuration Register** is used to indicate and control the current status/setup of the RTX microcontroller, through the bit assignments shown in Figure 3. This register is accessed explicitly through read and write operations, which cause interrupts to be suppressed for one cycle, guaranteeing that the next instruction will be performed before an interrupt Acknowledge cycle is allowed to be performed.

PC : The **Program Counter Register** contains the address of the next instruction to be fetched from Main Memory. At RESET, the contents of **PC** are set to 0.

I : The **Index Register** contains 16 bits of the 21-bit top element of the Return Stack, and is also used to hold the count for streamed and loop instructions (see Figure 11). In addition, **I** can be used to hold data and can be written from **TOP**. The contents of **I** may be accessed in either the push/pop mode in which values are moved to/from stack memory as required, or in the read/write mode in which the stack memory is not affected. The ASIC address used for **I** determines what type of operation will be performed (see

Table 11). When the Streamed Instruction Mode is used, a count is written to **I** and the next instruction is executed that number of times plus one (i.e. count + 1).

MD : The **Multiply/Divide Register** holds the divisor during Step Divide operations, while the 32-bit dividend is in **TOP** and **NEXT**. During Step Multiply operations, **MD** holds the multiplier, while **NEXT** holds the multiplicand. **MD** may also be used as a general purpose scratch pad register.

SR : The **Square Root Register** holds the intermediate values used during Step Square Root calculations. **SR** may also be used as a general purpose scratch pad register.

On-Chip Peripheral Registers

The RTX 2001A has an on-chip Interrupt Controller, a Memory Page Controller, two Stack Controllers, and three Timer/Counters. Each of these peripherals utilizes on-chip registers to perform its functions. Two additional RTX 2001A on-chip peripheral registers provide for scratchpad or scratchpad/counting functions.

TIMER/COUNTER REGISTERS

TC0, **TC1**, **TC2** : The **Timer/Counter Registers** are 16-bit read-only registers which contain the current count value for each of the three Timer/Counters. The counter is decremented at each rising clock edge of TCLK. Reading from these registers at any time does not disturb their contents. The sequence of Timer/Counter operations is shown in Figure 15 in the Timer/Counters section.

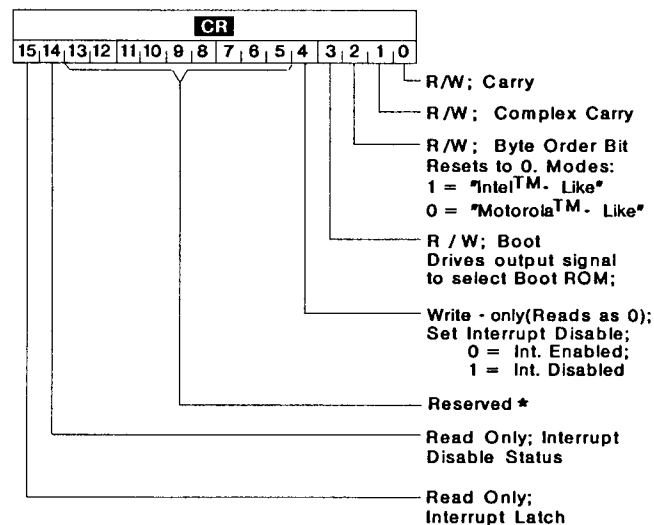

FIGURE 3. **CR** BIT ASSIGNMENTS

Motorola™ is a registered trademark of Motorola Inc.
Intel™ is a registered trademark of Intel Corporation

* NOTE: Always read as "0". Should be set = 0 during Write operations.

TP0 , TP1 , TP2 : The **Timer Preload Registers** are write-only registers which contain the initial 16-bit count values which are written to each timer. After a timer counts down to zero, the preload register for that timer reloads its initial count value to that timer register at the next rising clock edge, synchronously with TCLK. Writing to these registers causes the count to be loaded into the corresponding Timer/Counter register on the following cycle.

HOLDING/COUNTER SCRATCHPAD REGISTERS

RH : The **RH Scratchpad Register** is a read/write 16-bit scratchpad register for data storage, which provides faster access than to memory or a location buried in the stack.

RX : The **RX Scratchpad Register** can be used as a read/write 16-bit scratchpad register (like **RH**). In addition, **RX** can be used as a 16-bit, program controlled, counting register which automatically increments or decrements the contents of **RX** by one when it is read or written with specialized instructions (see Table 12). Incrementing the register contents beyond the "all ones" state results in a wrap to the "all zeros" state. Decrementing the register below the "all zeros" state results in a wrap to the "all ones" state.

INTERRUPT CONTROLLER REGISTERS

IVR : The **Interrupt Vector Register** is a read-only register which holds the current Interrupt Vector value. See Figure 4 and Table 7.

IBC : The **Interrupt Base/Control Register** is used to store the Interrupt Vector base address and to specify configuration information for the processor, as indicated by the bit assignments in Figure 5.

IMR : The **Interrupt Mask Register** has a bit assigned for each maskable interrupt which can occur. When a bit is set, the interrupt corresponding to that bit will be masked. Only the Non-Maskable Interrupt (NMI) cannot be masked. See Figure 6 for bit assignments for this register.

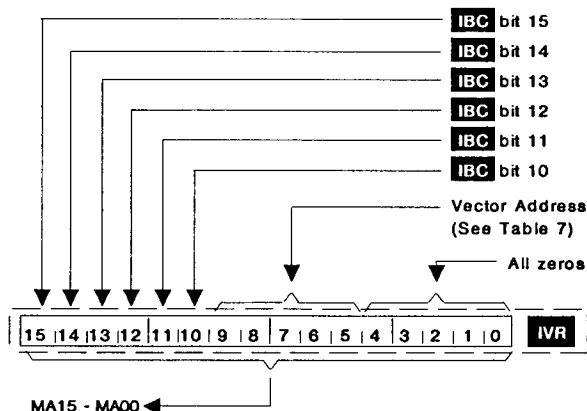

FIGURE 4. **IVR** BIT ASSIGNMENTS

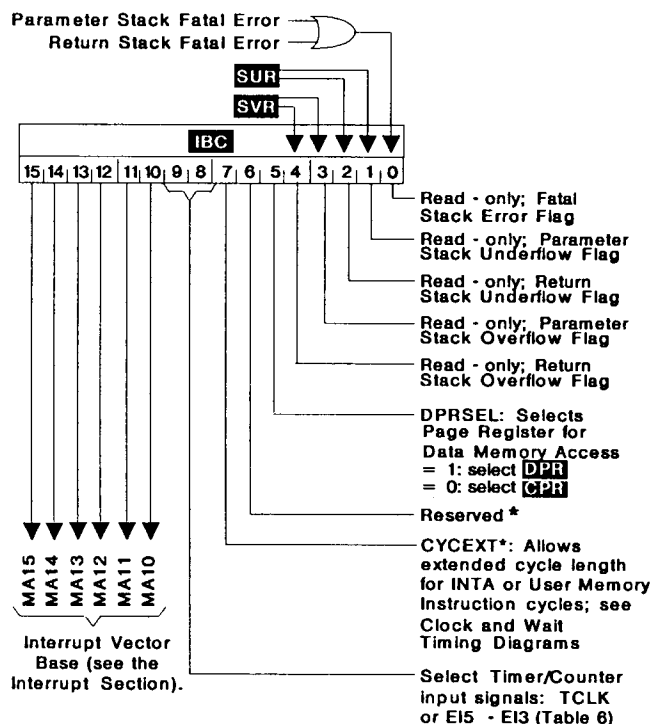

FIGURE 5. **IBC** BIT ASSIGNMENTS

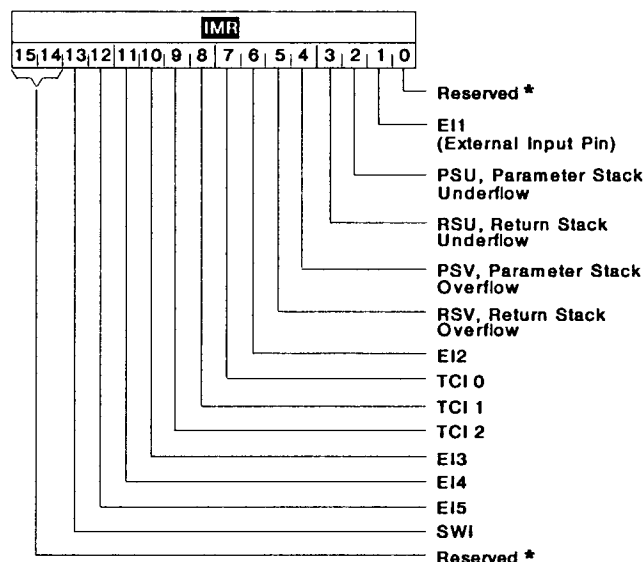

FIGURE 6. **IMR** BIT ASSIGNMENTS

* NOTE: Always read as "0". Should be set = 0 during Write operations.

STACK CONTROLLER REGISTERS

SPR : The **Stack Pointer Register** holds the stack pointer value for each stack. Bits 0-5 represent the next available stack memory location for the Parameter Stack, while bits 8-13 represent the next available stack memory location for the Return Stack. These stack pointer values must be accessed together, as **SPR** . See Figure 7.

SVR : The **Stack Overflow Limit Register** is a write-only register which holds the overflow limit values (0 to 63) for the Parameter Stack (bits 0-4) and the Return Stack (bits 8-12). These values must be written together. See Figure 8.

SUR : The **Stack Underflow Limit Register** holds the underflow limit values for the Parameter Stack and the Return Stack. In addition, this register is utilized to define the use of substacks for both stacks. These values must be accessed together. See Figure 9.

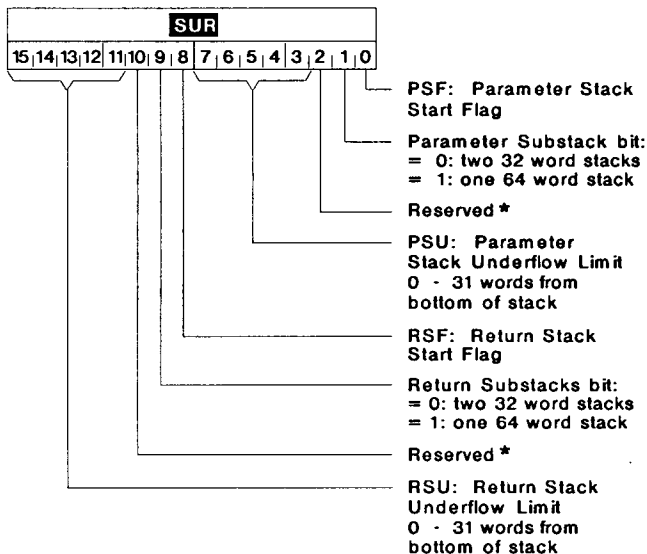

FIGURE 9. **SUR** BIT ASSIGNMENTS

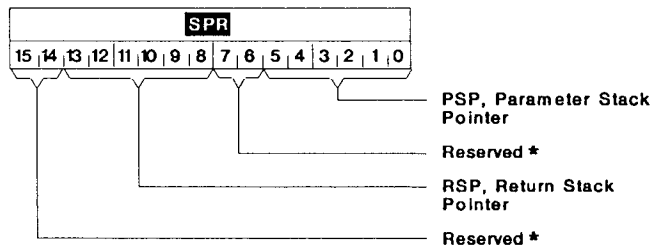

FIGURE 7. **SPR** BIT ASSIGNMENTS

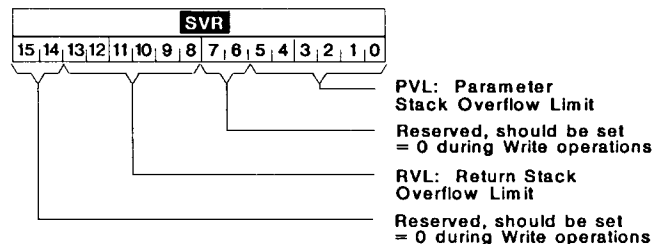

FIGURE 8. **SVR** BIT ASSIGNMENTS

* NOTE: Always read as "0". Should be set = 0 during Write operations.

MEMORY PAGE CONTROLLER REGISTERS

CPR : The **Code Page Register** contains the value for the current 32K-word Code page. See Figure 10 for bit field assignments.

IPR : The **Index Page Register** extends the Index Register (IP) by 5 bits; i.e. when a Subroutine Return is performed, the IPR contains the Code page from which the subroutine was called, and comprises the 5 most significant bits of the top element of the Return Stack. See Figure 11. During non-subroutine operation, writing to IPR causes the current Code page value to be written to IPR. Reading or writing directly to IPR does not push the Return Stack.

DPR : The **Data Page Register** contains the value for the current 32K-word Data page. See Figure 12 for bit field assignments.

UPR : The **User Page Register** contains the value for the current User page. See Figure 13 for bit field assignments.

UBR : The **User Base Address Register** contains the base address for User Memory Instructions. See Figure 13 for bit field assignments.

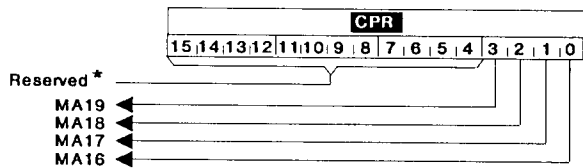

FIGURE 10. CPR BIT ASSIGNMENTS

Initialization of Registers

Initialization of the on-chip registers occurs when a HIGH level on the RTX RESET pin is held for a period longer than four ICLK cycles. While the RESET input is HIGH, the TCLK and PCLK clock outputs are held reset in the LOW state.

Table 4 shows initialization values and ASIC addresses for the on-chip registers. As indicated, both the PC and the CPR are cleared and execution begins at page 0, word 0 when the processor is reset.

The RESET has a Schmitt trigger input, which allows the use of a simple RC network for generation of a power-on RESET signal. This helps to minimize the circuit board space required for the RESET circuit.

To ensure reliable operation even in noisy embedded control environments, the RESET input is filtered to prevent a reset caused by a glitch of less than one ICLK cycle.

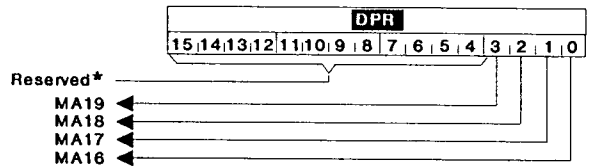

FIGURE 12. DPR BIT ASSIGNMENTS

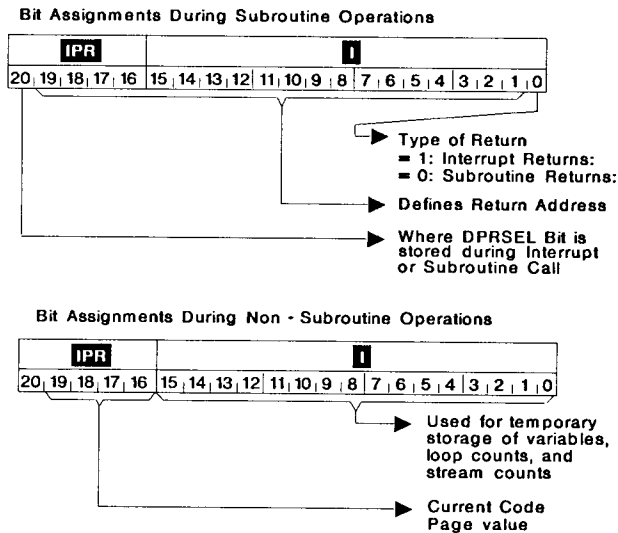

FIGURE 11. IP AND IPR BIT ASSIGNMENTS

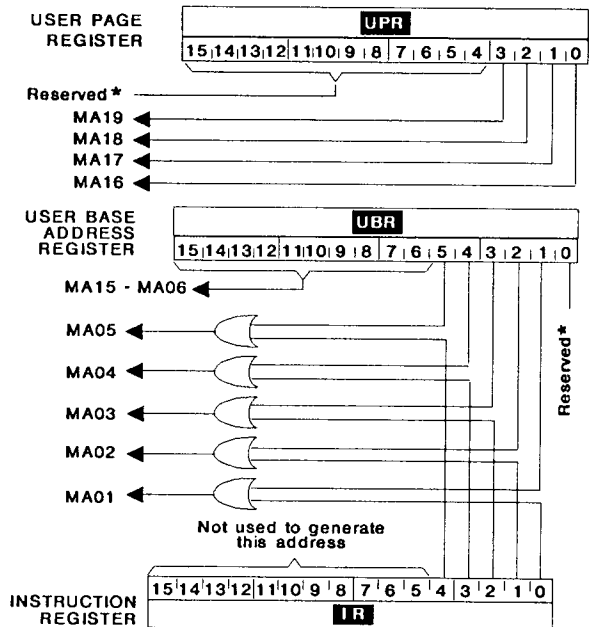

FIGURE 13. UPR AND UBR BIT ASSIGNMENTS

* Note: Always read as "0". Should be set = 0 during Write operations

RTX 2001A

TABLE 4. REGISTER INITIALIZATION AND ASIC ADDRESS ASSIGNMENTS

REGISTER	HEX ADDR	INITIALIZED CONTENTS	DESCRIPTION/COMMENTS
TOP		0000 0000 0000 0000	Top Register
NEXT		1111 1111 1111 1111	Next Register
IR		0000 0000 0000 0000	Instruction Register
I	00H 01H 02H	1111 1111 1111 1111	Index Register
CR	03H	0100 0000 0000 1000	Configuration Register: Boot=1; Interrupts disabled; Byte Order=0.
MD	04H	1111 1111 1111 1111	Multiply/Divide Register
SR	06H	0000 0000 0000 0000	Square Root Register
PC	07H	0000 0000 0000 0000	Program Counter Register
IMR	08H	0000 0000 0000 0000	Interrupt Mask Register
SPR	09H	0000 0000 0000 0000	Stack Pointer Register: The beginning address for each stack is set to a value of '0'.
SUR	0AH	0000 0011 0000 0011	Stack Underflow Limit Register
IVR	0BH	0000 0010 0000 0000	Interrupt Vector Register: Read only; this register holds the current Interrupt Vector value, and is initialized to the "No Interrupt" value.
SVR	0BH	1111 1111 1111 1111	Stack Overflow Limit Register: Write-only; Each stack limit is set to its maximum value.
IPR	0CH	0000 0000 0000 0000	Index Page Register
DPR	0DH	0000 0000 0000 0000	Data Page Register: The Data Address Page is set for page '0'.
UPR	0EH	0000 0000 0000 0000	User Page Register: The User Address Page is set for page '0'.
CPR	0FH	0000 0000 0000 0000	Code Page Register: The Code Address Page is set for page '0'.
IBC	10H	0000 0000 0000 0000	Interrupt Base/Control Register
UBR	11H	0000 0000 0000 0000	User Base Address Register: The User base address is set to '0' within the User page.
TC0 / TP0	13H	0000 0000 0000 0000	Timer/Counter Register 0: Set to time out after 65536 clock periods or events.
TC1 / TP1	14H	0000 0000 0000 0000	Timer/Counter Register 1: Set to time out after 65536 clock periods or events.
TC2 / TP2	15H	0000 0000 0000 0000	Timer/Counter Register 2: Set to time out after 65536 clock periods or events.
RX	16H	0000 0000 0000 0000	Scratchpad/Counting Register
RH	17H	0000 0000 0000 0000	Scratchpad Register

Dual Stack Architecture

The RTX 2001A features a dual stack architecture. The two 64-word stacks are the Parameter Stack and the Return Stack, both of which may be accessed in parallel by a single instruction, and which minimize overhead in passing parameters between subroutines. The functional structure of each of these stacks is shown in Figure 14.

The Parameter Stack is used for temporary storage of data and for passing parameters between subroutines. The top two elements of this stack are contained in the **TOP** and **NEXT** registers of the processor, and the remainder of this stack is located in stack memory. The stack memory assigned to the Parameter Stack is 64 words deep by 16 bits wide.

The Return Stack is used for storing return addresses when performing Subroutine Calls, or for storing values temporarily. Because the RTX 2001A uses a separate Return Stack, it can call and return from subroutines and interrupts with a minimum of overhead. The Return Stack is 21 bits wide. The 16-bit **Index Register**, **I**, and the 5-bit **Index Page Register**, **IPR**, hold the top element of this stack, while the remaining elements are located in stack memory. The stack memory portion of the Return Stack is 21 bits wide, by 64 words deep.

The data on the Return Stack takes on different meaning, depending upon whether the Return Stack is being used for temporary storage of data or to hold a return address during a subroutine operation (Figure 11).

RTX 2001A STACK CONTROLLERS

The two stacks of the RTX 2001A are controlled by identical Programmable Stack Controllers.

The operation of the Programmable Stack Controllers depends on the contents of three registers. These registers are **SPR**, the **Stack Pointer Register**, **SVR**, the **Stack Overflow Limit Register**, and **SUR**, the **Stack Underflow Limit Register** (see Figures 7, 8, and 9).

SPR contains the location of the next stack memory location to be accessed in a stack push (write) operation. After a push, the **SPR** is incremented (post-increment operation). In a stack pop (read) operation, the stack memory location with an address one less than the **SPR** will be accessed, and then the **SPR** will be decremented (pre-decrement operation). At start-up, the first stack location to have data pushed into it is location zero.

Upper and lower limit values for the stacks are set into the **Stack Overflow Limit Register** and in the **Stack Underflow Limit Register**. These values allow interrupts to be generated prior to the occurrence of stack overflow or underflow error conditions. Since the RTX 2001A can take up to four clock cycles to respond to an interrupt, the values set in these registers should include a safety margin which allows valid stack operation until the processor executes the interrupt service routine.

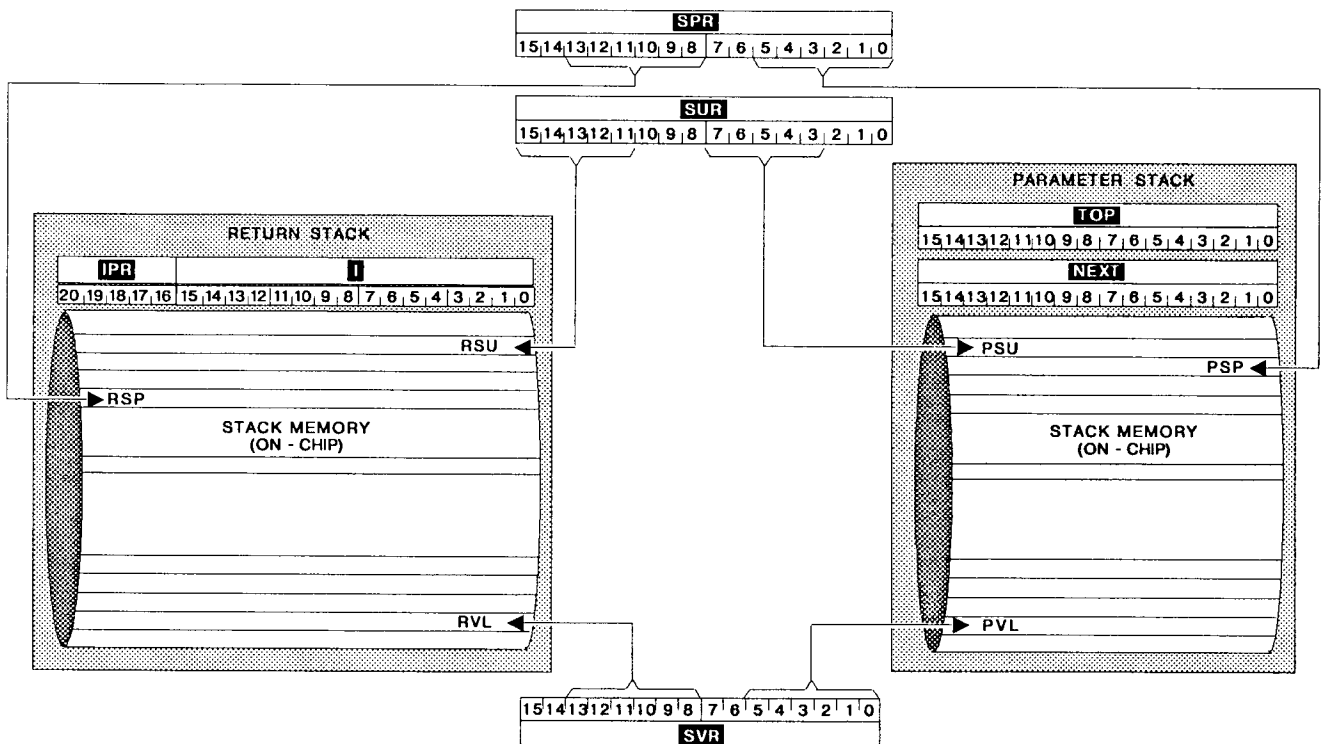

FIGURE 14. DUAL STACK ARCHITECTURE

SUBSTACKS

Each 64-word stack may be subdivided into two substacks under hardware control for simplified management of multiple tasks. Each substack contains 32 words of stack memory. Stack size is selected by writing to bit 1 of the **SVR** for the Parameter Stack, and bit 9 for the Return Stack.

Substacks are implemented by making bits 5 or 13 of the **SPR** control bits, i.e. they are not incremented when the stack size is 32 words. Because of this, a particular substack is selected by writing a value which contains both the stack pointer value and the substack number to the **SPR**.

Each stack has a Stack Start Flag (**PSF** and **RSF**) which is used for stack error detection (not for the stack pointer). For the Parameter Stack, the Start Flag is bit zero of the **SUR**, and for the Return Stack it is bit eight. If the Stack Start Flag is one, the stack starts at the bottom of the stack or substack (location 0). If the Stack Start Flag is zero, the substack starts in the middle of the stack. An exception to this occurs if the overflow limit in **SVR** is set for a location below the middle of the stack. In this case, the stacks always start at the bottom locations. See Table 5 for the possible stack configurations.

Manipulating the Stack Start Flag provides a mechanism for creating a virtual stack in memory which is maintained by interrupt driven handlers.

Possible applications for substacks include use as a recirculating buffer (to allow quick access for a series of repeated values such as coefficients for polynomial evaluation or a digital filter), or to log a continuous stream of data until a triggering event (for analysis of data before and after the trigger without having to store all of the incoming data). The latter application could be used in a digital oscilloscope or logic analyzer.

STACK ERROR CONDITIONS

Stack errors include overflow, underflow, and fatal errors. Overflows occur when an attempt is made to push data onto a full stack. Since the stacks wrap around, the result is that existing data on the stack will be overwritten by the new data when an overflow occurs. Underflows occur when an attempt is made to pop data off an empty stack, causing invalid data to be read from the stack. In both cases, a buffer zone may be set up by initializing **SVR** and **SUR** so that stack error interrupts are generated prior to an actual overflow or

TABLE 5. STACK/SUBSTACK CONFIGURATIONS FOR GIVEN CONTROL BIT SETTINGS

CONTROL BIT SETTINGS:						PARAMETER STACK CONFIGURATION:															
SPR		SVR		SUR		STACK SIZE (WORDS)	STACK RANGE		FATAL LIMIT	UNDERFLOW LIMIT						OVERFLOW LIMIT					
P5	V5	V4	U2	U1	U0		LOWEST ADDRESS	HIGHEST ADDRESS		5	4	3	2	1	0	5	4	3	2	1	0
0	X	0	0	0	X	32	0	31	31	0	0	U6	U5	U4	U3	0	0	V3	V2	V1	V0
0	X	1	0	0	0	32	0	31	15	0	1	U6	U5	U4	U3	0	0	V3	V2	V1	V0
0	X	1	0	0	1	32	0	31	31	0	0	U6	U5	U4	U3	0	1	V3	V2	V1	V0
1	X	0	0	0	X	32	32	63	63	1	0	U6	U5	U4	U3	1	0	V3	V2	V1	V0
1	X	1	0	0	0	32	32	63	47	1	1	U6	U5	U4	U3	1	0	V3	V2	V1	V0
1	X	1	0	0	1	32	32	63	63	1	0	U6	U5	U4	U3	1	1	V3	V2	V1	V0
X	0	X	0	1	X	64	0	63	63	0	U7	U6	U5	U4	U3	0	V4	V3	V2	V1	V0
X	1	X	0	1	0	64	0	63	31	1	U7	U6	U5	U4	U3	0	V4	V3	V2	V1	V0
X	1	X	0	1	1	64	0	63	63	0	U7	U6	U5	U4	U3	1	V4	V3	V2	V1	V0

CONTROL BIT SETTINGS:						RETURN STACK CONFIGURATION:															
SPR		SVR		SUR		STACK SIZE (WORDS)	STACK RANGE		FATAL LIMIT	UNDERFLOW LIMIT						OVERFLOW LIMIT					
P13	V13	V12	U10	U9	U8		LOWEST ADDRESS	HIGHEST ADDRESS		5	4	3	2	1	0	5	4	3	2	1	0
0	X	0	0	0	X	32	0	31	31	0	0	U14	U13	U12	U11	0	0	V11	V10	V9	V8
0	X	1	0	0	0	32	0	31	15	0	1	U14	U13	U12	U11	0	0	V11	V10	V9	V8
0	X	1	0	0	1	32	0	31	31	0	0	U14	U13	U12	U11	0	1	V11	V10	V9	V8
1	X	0	0	0	X	32	32	63	63	1	0	U14	U13	U12	U11	1	0	V11	V10	V9	V8
1	X	1	0	0	0	32	32	63	47	1	1	U14	U13	U12	U11	1	0	V11	V10	V9	V8
1	X	1	0	0	1	32	32	63	63	1	0	U14	U13	U12	U11	1	1	V11	V10	V9	V8
X	0	X	0	1	X	64	0	63	63	0	U15	U14	U13	U12	U11	0	V12	V11	V10	V9	V8
X	1	X	0	1	0	64	0	63	31	1	U15	U14	U13	U12	U11	0	V12	V11	V10	V9	V8
X	1	X	0	1	1	64	0	63	63	0	U15	U14	U13	U12	U11	1	V12	V11	V10	V9	V8

- NOTES: 1. **SPR** - Stack Pointer Register; **SVR** - Stack Overflow Limit Register; **SUR** - Stack Underflow Limit Register
 2. P0 through P15 are the **SPR** bits; V0 through V15 are the **SVR** bits; U0 through U15 are the **SUR** bits.
 3. The Overflow Limit is the stack memory address at which an overflow condition will occur during a stack write operation.
 4. The Underflow Limit is the stack memory address below which an underflow condition will occur during a stack read operation.
 5. The Fatal Limit is the stack memory address at which a fatal error condition will occur during a stack read or write operation.
 6. Stack error conditions remain in effect until a new value is written to the **SPR**.
 7. Stacks and substacks are circular: After writing to the highest location in the stack, the next location to be written to will be the lowest location; after reading the lowest location, the highest location will be read next.

underflow. The limits may be determined from the contents of **SVR** and **SUR** using Table 5. The state of all stack errors may be determined by examining the five least significant bits of **IBC**, where the stack error flags may be read but not written to. All stack error flags are cleared whenever a new value is written to **SPR**.

FATAL STACK ERROR: Each stack can also experience a fatal stack error. This error condition occurs when an attempt is made to push data onto or to pop data off of the highest location of the substack. It does not generate an interrupt (since the normal stack limits can be used to generate the interrupt). The fatal errors for the stacks are logically OR'ed together to produce bit 0 of the **Interrupt Base Control Register**, and they are cleared whenever **SPR** is written to. The implication of a fatal error is that data on the stack may have been corrupted or that invalid data may have been read from the stack.

RTX 2001A Timer/Counters

The RTX 2001A has three 16-bit timers, each of which can be configured to perform timing or event counting. All decrement synchronously with the rising edge of TCLK. Timer registers are readable in a single machine cycle.

The timer selection bits of the **IBC** determine whether a timer is to be configured for external event counting or internal time-base timing. This configures the respective counter clock inputs to the on-chip TCLK signal for internal timing, or to the EI5-EI3 input pins for external signal event counting. EI5, EI4, and EI3 are synchronized internally with TCLK. See Table 6 for Timer/Clock selection by **IBC** bit values.

TABLE 6. TIMER/CLOCK SECTION

IBC BIT VALUES		TIMER CLOCK SOURCE		
BIT 09	BIT 08	TC2	TC1	TC0
0	0	TCLK	TCLK	TCLK
0	1	TCLK	TCLK	EI3
1	0	TCLK	EI4	EI3
1	1	EI5	EI4	EI3

The timers (**TC0**, **TC1** and **TC2**) are all free-running, and when they time out, they reload automatically with the programmed initial value from their respective Timer Preload Registers (**TP0** → **TC0**, **TP1** → **TC1**, and **TP2** → **TC2**), then continue timing or counting.

Each timer provides an output to the Interrupt Controller to indicate when a time-out for the timer has occurred.

The RTX 2001A can determine the state of a timer at any time either by reading the timer's value, or upon a time-out by using the timer's interrupt (see the Interrupt Controller section for more information about how timer interrupts are handled). Figure 15 shows the sequence of Timer/Counter operations.

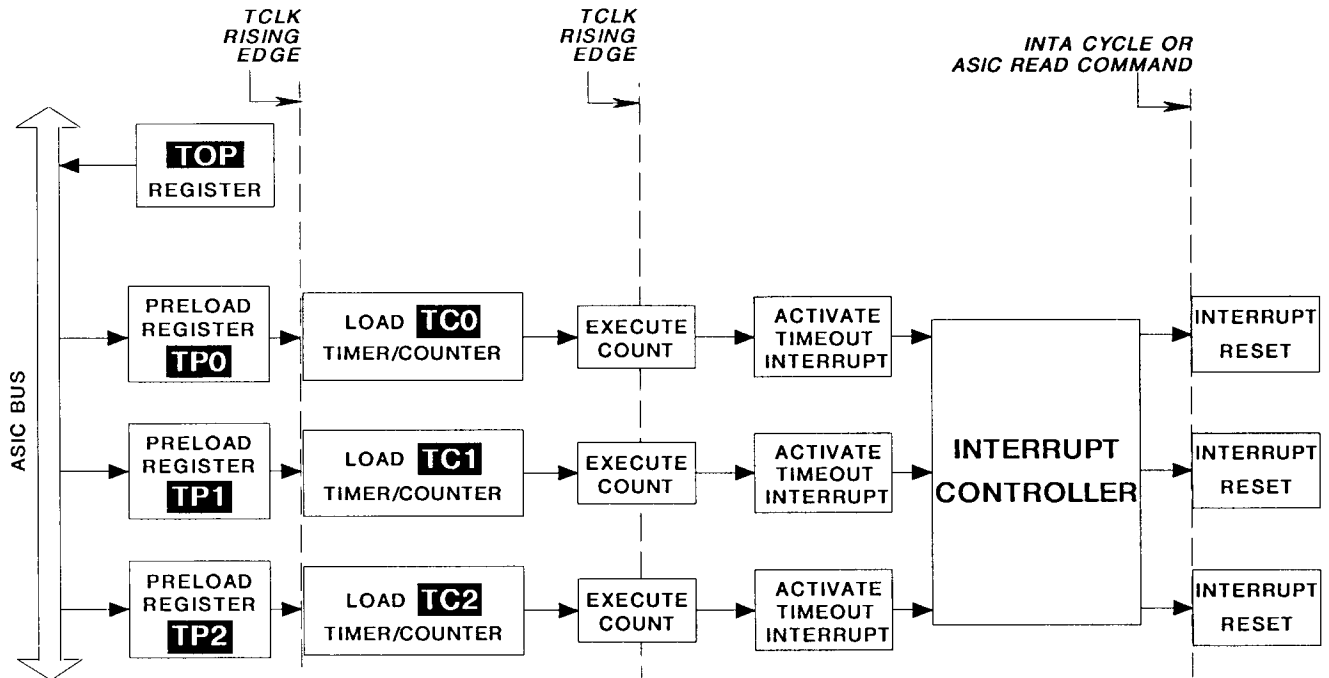

FIGURE 15. RTX 2001A TIMER/COUNTER OPERATION

RTX Interrupt Controller

The RTX 2001A Interrupt Controller manages interrupts for the RTX 2001A Microcontroller core. Its sources include two on-chip peripherals and six external interrupt inputs. The two classes of on-chip peripherals that produce interrupts are the Stack Controllers and the Timer/Counters.

INTERRUPT CONTROLLER OPERATION

When one of the interrupt sources requests an interrupt, the Interrupt Controller checks whether the interrupt is masked in the **Interrupt Mask Register**. If it is not, the controller attempts to interrupt the processor. If processor interrupts are enabled (bit 4 of the **Configuration Register**), the processor will execute an Interrupt Acknowledge cycle, during which it disables interrupts to ensure proper completion of the INTA cycle.

In response to the Interrupt Acknowledge cycle, the Interrupt Controller places an Interrupt Vector on the internal ASIC Bus, based on the highest priority pending interrupt. The processor performs a special Subroutine Call to the address in Memory Page 0 contained in the vector. This special subroutine call is different in that it saves a status bit on the Return Stack indicating the call was caused by an interrupt. Thus, when the Interrupt Handler executes a Subroutine Return, the processor knows to automatically re-enable interrupts. Before the Interrupt Handler returns, it must

ensure that the condition that caused the interrupt is cleared. Otherwise the processor will again be interrupted immediately upon its return.

Processor interrupts are enabled and disabled by clearing and setting the **Interrupt Disable Flag**. When the RTX is reset, this flag is set (bit 04 of the **CR** =1), disabling the interrupts. This bit is a write-only bit that always reads as 0, allowing interrupts to be enabled in only 2 cycles with a simple read/write operation in which the processor reads the bit value, then writes it back to the same location. The actual status of the Interrupt Disable Flag can be read from bit 14 of **CR**.

During read and write operations to the **Configuration Register**, (**CR**), interrupts are inhibited to allow the program to save and restore the state of the Interrupt Enable bit, allowing safe manipulation of the **Stack Pointer Register**.

In addition to disabling interrupts at the processor level, all interrupts except the **Non-Maskable Interrupt (NMI)** can be individually masked by the Interrupt Controller by setting the appropriate bit in the **Interrupt Mask Register (IMR)**. Resetting the RTX 2001A causes all bits in the **IMR** to be cleared, thereby unmasking all interrupts.

TABLE 7. INTERRUPT SOURCES, PRIORITIES AND VECTORS

PRIORITY	INTERRUPT SOURCE		SENSITIVITY	IMR BIT	VECTOR ADDRESS BITS				
					09	08	07	06	05
0 (High)	NMI	Non-Maskable Interrupt	Pos Edge	N/A	0	1	1	1	1
1	EI1	External Interrupt 1	High Level	01	0	1	1	1	0
2	PSU	Parameter Stack Underflow	High Level	02	0	1	1	0	1
3	RSU	Return Stack Underflow	High Level	03	0	1	1	0	0
4	PSV	Parameter Stack Overflow	High Level	04	0	1	0	1	1
5	RSV	Return Stack Overflow	High Level	05	0	1	0	1	0
6	EI2	External Interrupt 2	High Level	06	0	1	0	0	1
7	TCI0	Timer/Counter 0	Edge	07	0	1	0	0	0
8	TCI1	Timer/Counter 1	Edge	08	0	0	1	1	1
9	TCI2	Timer/Counter 2	Edge	09	0	0	1	1	0
10	EI3	External Interrupt 3	High Level	10	0	0	1	0	1
11	EI4	External Interrupt 4	High Level	11	0	0	1	0	0
12	EI5	External Interrupt 5	High Level	12	0	0	0	1	1
13 (Low)	SWI	Software Interrupt	High Level	13	0	0	0	1	0
N/A	None	No Interrupt	N/A	N/A	1	0	0	0	0

The Interrupt Controller prioritizes interrupt requests and generates an Interrupt Vector for the highest priority interrupt request. The address that the vector points to is determined by the source of the interrupt and the contents of the **Interrupt Base/Control Register (IBC)**. See Figure 4 for the **Interrupt Vector Register** bit assignments. Because address bits MA19-MA16 are always zero in an Interrupt Acknowledge cycle, the entry point to the Interrupt Handlers must reside on Memory Page zero.

Because address bits MA04-MA01 are always zero in an Interrupt Acknowledge cycle, Interrupt Vectors are 32 bytes apart. This means that Interrupt Handler routines that are 32 bytes or less can be compiled directly into the Interrupt Table. Interrupt Handlers greater than 32 bytes must be compiled separately and called from the Interrupt Table.

The rest of the vector is generated as indicated in Table 7. To guarantee that the Interrupt Vector will be stable during an INTA cycle, the Interrupt Controller inhibits the generation of a new Interrupt Vector while INTA is high, and will not begin generating a new Interrupt Vector on either edge of INTA.

The Interrupt Vector can also be read from the **Interrupt Vector Register (IVR)** directly. This allows interrupt requests to be monitored by software, even if they are disabled by the processor. If no interrupts are being requested, bit 09 of the **IVR** will be 1.

External interrupts EI5-EI1 are active HIGH level-sensitive inputs. Therefore, the Interrupt Handlers for these interrupts must clear the source of interrupt prior to returning to the interrupted code. The external **NMI**, however, is an edge-sensitive input which requires a rising edge to request an interrupt. The **NMI** input also has a glitch filter circuit which requires that the signal that initiates the **NMI** must last at least two cycles of ICLK.

Finally, a mechanism is provided by which an interrupt can be requested by using a software command. The Software Interrupt (**SWI**) is requested by executing an instruction that will set an internal flip-flop attached to one input of the Interrupt Controller. The **SWI** is reset by executing an instruction that clears the flip-flop. The flip-flop is accessed by I/O Reads and Writes.

Because the **SWI** interrupt may not be serviced immediately, the instructions which immediately follow the **SWI** instruction should not depend on whether or not the interrupt has been serviced, and should cause a one- or two-cycle idle condition (Typically, this is done with one or two NOP instructions).

If an interrupt condition occurs, but "goes away" before the processor has a chance to service it, a "No Interrupt" vector is generated. A "No Interrupt" vector is also generated if an Interrupt Acknowledge cycle takes less than two cycles to execute and no other interrupt conditions need to be serviced.

To prevent unforeseen errors, it is recommended that valid code be supplied at every Interrupt Vector location, including the "No Interrupt" vector, which should always be initialized with valid code.

It is recommended that Interrupt Handlers save and restore the contents of **CR**.

INTERRUPT SUPPRESSION

The RTX 2001A allows maskable interrupts to be suppressed, delaying them temporarily while critical operations are in progress. Critical operations are instruction sequences and hardware operations that, if interrupted, would result in the loss of data or misoperation of the hardware.

Standard critical operations during which interrupts are automatically suppressed by the processor include Streamed instructions (see the description of the **I** register), Long Call sequences (see "Subroutine Calls and Returns"), and loading **CR**. In addition to this, user defined, external devices can also suppress interrupts during critical operations by applying a HIGH level on the **INTSUP** pin for as long as required.

Since the **NMI** can still cause the processor to perform an Interrupt Acknowledge cycle in the middle of these critical operations thereby preventing a normal return to the interrupted instruction, a Subroutine Return should be used with care from the **NMI** service routine. For this reason, the **NMI** should be used only to indicate critical system errors, and the **NMI** handler should re-initialize the system.

Interrupts which have occurred while interrupt suppression is in effect will be recognized on a priority basis as soon as the suppression terminates, provided the condition which generated the interrupt has not "gone away".

STACK ERROR INTERRUPTS

The Stack Controllers request an interrupt whenever a stack overflow or underflow condition exists. These interrupts can be cleared by rewriting **SPR**. See the section on "Dual Stack Architecture" for more information regarding how the limits set into **SVR** and **SUR** are used.

STACK OVERFLOW: A stack overflow occurs when data is pushed onto the stack location pointed to by the **SVR**, as determined in Table 5. After the processor is reset, this is location 63 in either the Parameter Stack or Return Stack. A stack overflow interrupt request stays in effect until cleared by writing a new value to the **SPR**. In addition to generating an interrupt, the state of the stack overflow flags may be read out of the **IBC**, bit 3 for the Parameter Stack, and bit 4 for the Return stack. See Figures 5, 7 and 8.

STACK UNDERFLOW: The stack underflow limit occurs when data is popped off the stack location immediately below that pointed to by the **SUR**, as determined in Table 5. The state of the stack underflow error flags may be read out of bits 1 and 2 of the **IBC** for the Parameter and Return stacks respectively. In the reset state of the **SUR**, an underflow will be generated at the same time that a fatal error is detected. An underflow buffer region can be set up by selecting an underflow limit greater than zero by writing the corresponding value into the **SUR**. The stack underflow interrupt request stays in effect until a new value is written into the **SPR**, at which time it is cleared.

TIMER/COUNTER INTERRUPTS

The timers generate edge-sensitive interrupts whenever they are decremented to 0. Because they are edge-sensitive and are cleared during an Interrupt Acknowledge cycle or during the direct reading of **IVR** by software, no action is required by the handlers to clear the interrupt request.

The RTX 2001A ALU

The RTX 2001A has a 16-bit ALU capable of performing standard arithmetic and logic operations:

- ADD and SUBTRACT (A-B and B-A; with and without carry)
- AND, OR, XOR, NOR, NAND, XNOR, NOT

The **TOP** and **NEXT** registers can also undergo single bit shifts in the same cycle as a logic or arithmetic operation.

In Figure 16, the control and data paths to the ALU are shown. Except for **TOP** and **NEXT**, each of the internal core registers can be addressed explicitly, as can other internal registers in special operations such as in Step instructions. In each of these cases, the input would be addressed as a device on the ASIC Bus.

When executing these instructions, the arithmetic/logic operand (a) starts out in **TOP** and is placed on the T-bus. Operand (b) arrives at the ALU on the Y-bus, but can come from one of the following four sources: **NEXT**; an internal

register; an ASIC Bus device; or from the 5 least significant bits of **IR**. The source of operand (b) is determined by the instruction code in **IR**. The result of the ALU operation is placed into **TOP**.

Step Arithmetic instructions which are performed through the ALU are multiply, divide, and square root. Execution of each step of the arithmetic operation takes one cycle, a 16/32-bit Step Multiply takes 20 cycles, a 32/16-bit Step Divide takes 21 cycles, and a 32/16-bit Step Square Root takes 25 cycles. Sign and scaling functions are controlled by the ALU function and shift options, which are part of the coded instruction contained in **IR**. See Table 24 and the Programmer's Reference Manual for details.

Signed (2's complement) Step Multiply operation begins with the multiplier in **MD** and the multiplicand in **NEXT**. If the LSB of **NEXT** equals 1, the contents of **MD** are added to **TOP**. Otherwise, the contents of **TOP** are left unchanged. A 32-bit right shift of **TOP** and **NEXT** is then performed, shifting the value of CY (the value of the Carry bit before the operation) into the MSB of **TOP**. When this operation has been performed 15 times, the LSB of **NEXT** is again tested. If it is equal to 0, the contents of **TOP** are unchanged. Otherwise, the contents of **TOP** are subtracted from **MD**, leaving the result in **TOP**. Another 32-bit right shift of **TOP** and **NEXT** is again performed. When completed, the 32-bit result will be in **TOP** and **NEXT**, with the most significant word located in **TOP**. If the operation began with **TOP** initialized to a value other than zero, that value will be accumulated with the product.

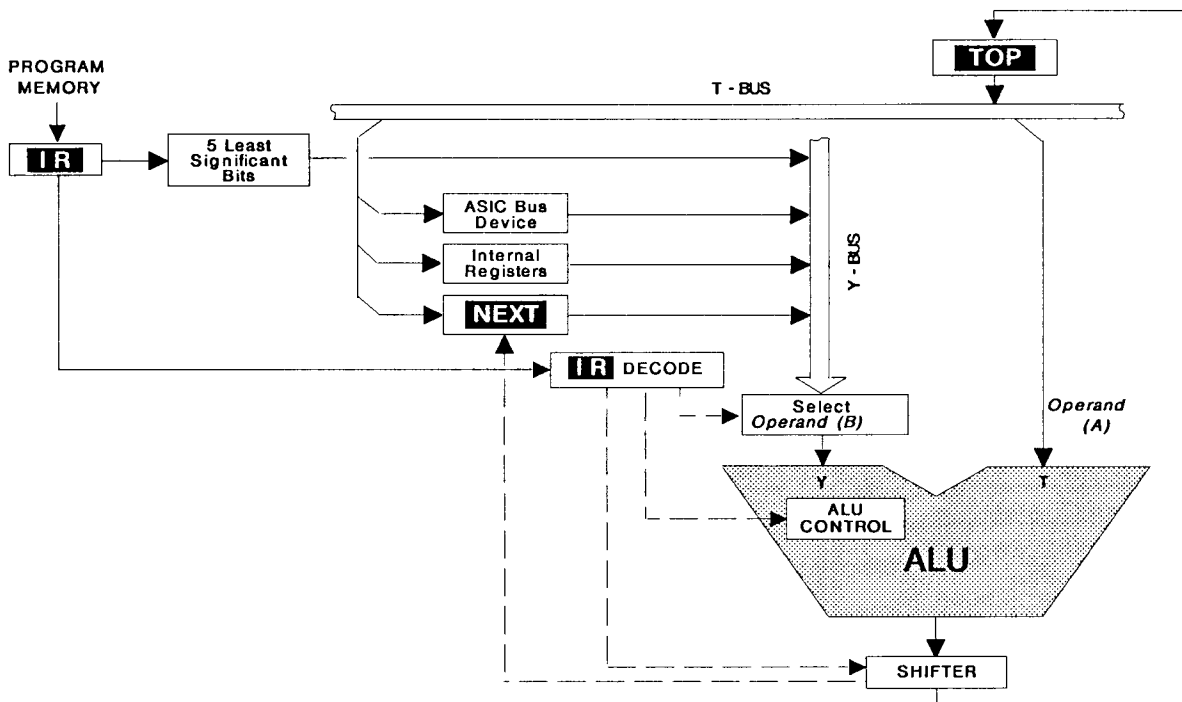

NOTE: Data Paths are represented by solid lines; Control Paths are represented by dashed lines.

FIGURE 16. ALU OPERATIONS-CONTROL PATHS AND DATA FLOW

Unsigned Step Divide operation assumes a double precision (32-bit) dividend, with the most significant word placed in **TOP**, the less significant word in **NEXT**, and the divisor in **MD**. In each step, if the contents in **TOP** are equal to or greater than the contents in **MD** (and therefore no borrow is generated), then the contents of **MD** are subtracted from the contents of **TOP**. The result of the subtraction is placed into **TOP**. The contents of **TOP** and **NEXT** are then jointly shifted left one bit (32-bit left shift), where the value shifted into the least significant bit of **NEXT** is the value of the Borrow bit on the first pass, or the value of the Complex Carry bit on each of the subsequent passes. On the 15th and final pass, only **NEXT** is shifted left, receiving the value of the Complex Carry bit into the LSB. **TOP** is not shifted. The final result leaves the quotient in **NEXT**, and the remainder in **TOP**.

During a Step Square Root operation, the 32-bit argument is assumed to be in **TOP** and **NEXT**, as in the Step Divide operation. The first step begins with **MD** containing zeros. The Step Square Root is performed much like the Step Divide, except that the input from the Y-bus is the logical OR of the contents of **SR** and the value in **MD** shifted one place to the left ($2 * MD$). When the subtraction is performed, **SR** is OR'ed into **MD**, and **SR** is shifted one place to the right. At the end of the operation, the square root of the original value is in **MD** and **NEXT**, and the remainder is in **TOP**.

RTX 2001A ASIC Bus Interface

The RTX 2001A ASIC Bus services both internal processor core registers and the on-chip peripheral registers, and eight external off-chip ASIC Bus locations. All ASIC Bus operations require a single cycle to execute and transfer a full 16-bit word of data. The external ASIC Bus maps into the last eight locations of the 32 location ASIC Address Space. The three least significant bits of the address are available as the ASIC Address Bus. The addresses therefore map as shown in Table 8.

TABLE 8. ASIC BUS MAP

ASIC BUS SIGNAL			ASIC ADDRESS
GA02	GA01	GA00	
0	0	0	18H
0	0	1	19H
0	1	0	1AH
0	1	1	1BH
1	0	0	1CH
1	0	1	1DH
1	1	0	1EH
1	1	1	1FH

RTX 2001A Memory Access

THE RTX 2001A MEMORY BUS INTERFACE

The RTX 2001A can address 1 Megabyte of memory, divided into 16 non-overlapping pages of 64K bytes. The memory page accessed depends on whether the memory access is for Code (instructions and literals), Data, User Memory, or Interrupt Code. The page selected also depends on the contents of the Page Control Registers: the Code Page Register (**CPR**), the Data Page Register (**DPR**), the User Page Register (**UPR**), and the Index Page Register (**IPR**). Furthermore, the User Base Address Register (**UBR**) and the Interrupt Base/Control Register (**IBC**) are used to determine the complete address for User Memory accesses and Interrupt Acknowledge cycles. External memory data is accessed through **NEXT**.

When executing code other than an Interrupt Service routine, the memory page is determined by the contents of the **CPR**. Bits 03-00 generate address bits MA19-MA16, as shown in Figure 10. The remainder of the address (MA15-MA01) comes from the Program Counter Register (**PC**). After resetting the processor, both the **PC** and the **CPR** are cleared and execution begins at page 0, word 0.

A new Code page is selected by writing a 4-bit value to the **CPR**. The value for the Code page is input to the **CPR** through a preload procedure which withholds the value for one clock cycle before loading the **CPR** to ensure that the next instruction is executed from the same Code page as the instruction which set the new Code page. Execution immediately thereafter will continue with the next instruction in the new page.

An Interrupt Acknowledge cycle is a special case of an Instruction Fetch cycle. When an Interrupt Acknowledge cycle occurs, the contents of the **CPR** and **PC** are saved on the Return Stack and then the **CPR** is cleared to point to page 0. The Interrupt Controller generates a 16-bit address, or "vector", which points to the code to be executed to process the interrupt. To determine how the Interrupt Vector is formed, refer to Figure 4 for the register bit assignments, and also to the Interrupt Controller section.

The page for data access is provided by either **CPR** or **DPR**, as shown in Figures 10 and 12. Data Memory Access instructions can be used to access data in a memory page other than that containing the program code. This is done by writing the desired page number into the Data Page Register (**DPR**) and setting bit 5 (**DPRSEL**) of the **IBC** register to 1. If **DPR** is set to equal **CPR**, or if **DPRSEL** = 0, data will be accessed in the Code page. The status of the **DPRSEL** bit is saved and restored as a result of a Subroutine Call or Return. When the RTX 2001A is reset, **DPR** points to page 0 and **DPRSEL** resets to 0, selecting the **CPR**.

USER MEMORY consists of blocks of 32 words that can be located anywhere in memory. The word being accessed in a block is pointed to by the five least significant bits of the User Memory instruction (see Table 20), eliminating the need to explicitly load an address into **TOP** before reading or writing to the location. Upon RTX 2001A reset, **UBR** is cleared and points to the block starting at word 0, while **UPR** is cleared so that it points to word 0. The word in the block is pointed to by the five least significant bits of the User Memory instruction and bits 05-01 of the **UBR**. These bits from these two registers are logically OR'ed to produce the address of the word in memory. See Figure 13.

WORD AND BYTE MAIN MEMORY ACCESS

Using Main Memory Access instructions, the RTX 2001A can perform either word or single byte Main Memory accesses, as well as byte swapping within 16-bit words.

Bit 12 of the Memory Access Opcode (see Table 19), is used to determine whether byte or word operations are to be performed (where bit 12 = 0 signifies a word operation, and bit 12 = 1 signifies a byte operation). In addition, the determination of whether a byte swap is to occur depends on which mode (the "Motorola-Like" or the "Intel-Like") is in effect, and on whether an even or odd address is being accessed (see Figures 17 and 18).

Whenever a word of data is read by a Data Memory operation into the processor, it is first placed in the **NEXT** register. By the time the instruction that reads that word of data is completed, however, the data may have been moved, optionally inverted, or operated on by the ALU, and placed in the **TOP** register. Whenever a Data Memory operation writes to memory, the data comes from the **NEXT** register.

The Byte Order Bit is bit 2 of the **Configuration Register, CR** (see Figure 3 in the "RTX Internal Registers Section). This bit is used to determine whether the default ("Motorola-Like") or byte swap ("Intel-Like") mode will be used in the Data Memory accesses.

Word Access is designated when the **IR** bit 12 = 0 in the Memory Access Opcode, and can take one of two forms, depending upon the status of **CR**, bit 2.

When **CR** bit 2 = 0, the "Motorola-Like" mode of word access (also known as the "Big Endian" mode) is designated. This mode of word access is to an even address (A0 = 0) and results in an unaltered transfer of data, as shown in Figure 17. Word access to/from an odd address (A0 = 1) while in this mode will effectively cause the Byte Order Bit to be complemented and will result in the bytes being swapped.

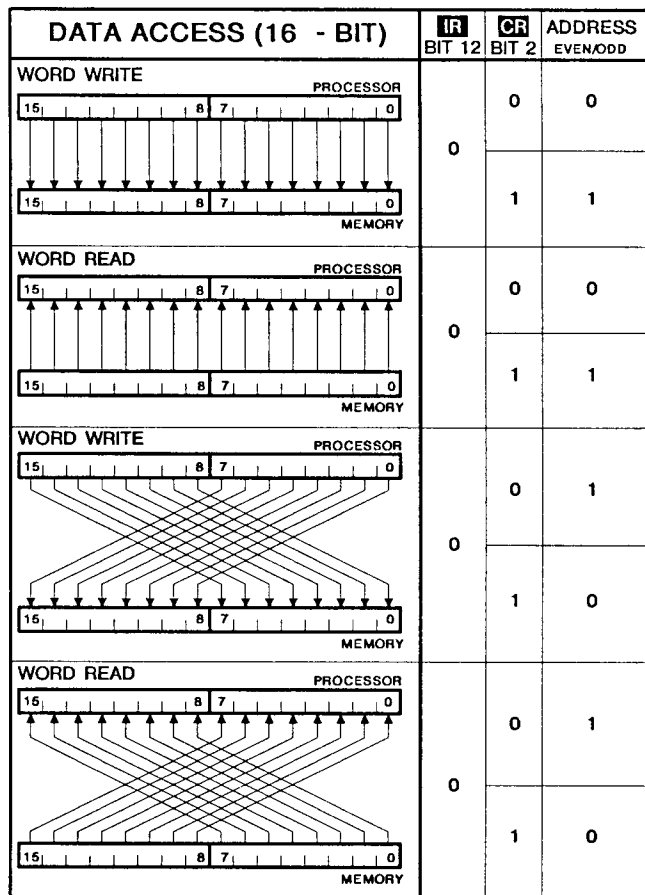

FIGURE 17. MEMORY ACCESS (WORD)

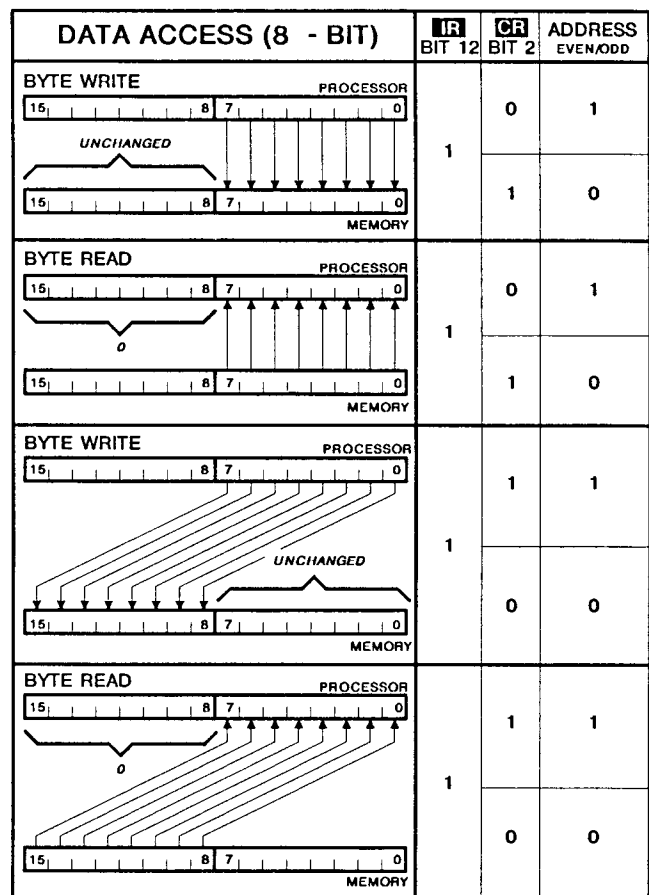

FIGURE 18. MEMORY ACCESS (BYTE)

When the **CR** Bit 2 = 1, the "Intel-Like" mode of word access is designated (also known as the "Little Endian" mode). Access to an even address (A0 = 0) results in a data transfer in which the bytes are swapped. Word access to an odd address (A0 = 1) while in this mode will effectively cause the Byte Order Bit to be complemented with the net result that no byte swap takes place when the data word is transferred. See Figure 17.

Byte Access is designated when the **IR** bit 12 = 1 in the Memory Access Opcode, and can also take one of two forms, depending on the value of **CR** Bit 2.

When the **CR** Bit 2 = 0, a *Byte Read* from an even address in the "Motorola-Like" mode causes the upper byte (MD15-MD08) of memory data to be read into the lower byte position (MD07-MD00) of **NEXT**, while the upper byte (MD15-MD08) is set to 0. A *Byte Write* operation accessing an even address will cause the byte to be written from the lower byte position (MD07-MD00) of **NEXT** into the upper byte position (MD15-MD08) of memory. The data in the lower byte position (MD07-MD00) in memory will be left unaltered. Accessing an odd address for either of these operations will cause the Byte Order Bit to be complemented, with the net result that no swap will occur. See Figure 18.

When **CR** Bit 2 = 1, memory is accessed in the "Intel-Like" mode. Accessing an even address in this mode means that a *Byte Read* operation will cause the lower byte of data to be transferred without a swap operation. A *Byte Write* in this mode will also result in an unaltered byte transfer. Conversely, accessing an odd address for a byte operation while in the "Intel-Like" Mode will cause the Byte Order Bit to be complemented. In a *Byte Read* operation, this will result in the upper byte (MD15-MD08) of data being swapped into the lower byte position (MD07-MD00), while the upper byte is set to 0 (MD15-MD08 set to 0). See Figure 18. A *Byte Write* operation accessing an odd address will cause the byte to be swapped from the lower byte position (MD07-MD00) of the processor register into the upper byte position (MD15-MD08) of the Memory location. The data in the lower byte position (MD07-MD00) in that Memory location will be left unaffected.

NOTE: These features are for Main Memory data access only, and have no effect on instruction fetches, long literals, or User Data Memory.

SUBROUTINE CALLS AND RETURNS

The RTX can perform both "short" subroutine calls and "long" subroutine calls. A short subroutine call is one for which the subroutine code is located within the same Code

page as the Call instruction, and no processor cycle time is expended in reloading the **CPR**.

Performing a long subroutine call involves transferring execution to a different Code page. This requires that the **CPR** be loaded with the new Code page as described in the Memory Access Section, followed immediately by the Subroutine Call instruction. This adds two additional cycles to the execution time for the Subroutine Call.

For all instructions except Subroutine Calls or Branch instructions, bit 5 of the instruction code represents the Subroutine Return Bit. If this bit is set to 1, a Return is performed whereby the return address is popped from the Return Stack, as indicated in Figure 11. The page for the return address comes from the **IPR**. The contents of the **I** register are written to the **PC**, and the contents of the **IPR** are written to the **CPR** so that execution resumes at the point following the Subroutine Call. The Return Stack is also popped at this time.

RTX 2001A Software

The RTX 2001A is designed around the same architecture as the RTX 2000, and is a hardware implementation of the Virtual Forth Engine. As such, it does not require the additional assembly or machine language software development typical of most real-time microcontrollers.

The instruction set for the RTX 2001A TForth compiler combines multiple high level instructions into single machine instructions without having to rely on either pipelines or caches. This optimization yields an effective throughput which is faster than the processor's clock speed, while avoiding the unpredictable execution behavior exhibited by most RISC processors caused by pipeline flushes and cache misses.

2001A COMPILERS

The RTX 2001A TForth compiler from Harris translates Forth-83 source code to RTX 2001A machine instructions. This compiler also provides support for all of the RTX 2001A instructions specific to the processor's registers, peripherals, and ASIC Bus. See the tables in the following sections for instruction set information.

A C compiler for the RTX 2001A is also available, and a Prolog compiler will be available at a later date for applications which require those languages.

TABLE 9. INSTRUCTION SET SUMMARY

NOTATIONS	
<i>m-read</i>	Read data (byte or word) from memory location addressed by contents of TOP register into TOP register.
<i>m-write</i>	Write contents (byte or word) of NEXT register into memory location addressed by contents of TOP register.
<i>g-read</i>	Read data from the ASIC address (address field <i>ggggg</i> of instruction) into TOP register. A read of one of the on-chip peripheral registers can be done with a <i>g-read</i> command.
<i>g-write</i>	Write contents of TOP register to ASIC address (address field <i>ggggg</i> of instruction). A write to one of the on-chip peripheral registers can be done with a <i>g-write</i> command.
<i>u-read</i>	Read contents (word only) of User Space location (address field <i>uuuuu</i> of instruction) into TOP register.
<i>u-write</i>	Write contents (word only) of TOP register into User Space location (address field <i>uuuuu</i> of instruction).
SWAP	Exchange contents of TOP and NEXT registers
DUP	Copy contents of TOP register to NEXT register, pushing previous contents of NEXT onto Stack Memory.
OVER	Copy contents of NEXT register to TOP register, pushing original contents of TOP to NEXT register and original contents of NEXT register to Stack Memory.
DROP	Pop Parameter Stack, discarding original contents of TOP register, leaving the original contents of NEXT in TOP and the original contents of the top Stack Memory location in NEXT .
<i>inv</i>	Perform 1's complement on contents of TOP register, if <i>i</i> bit in instruction is 1.
<i>alu-op</i>	Perform appropriate <i>cccc</i> or <i>aaa</i> ALU operation from Table 23 on contents of TOP and NEXT registers.
<i>shift</i>	Perform appropriate shift operation (<i>ssss</i> field of instruction) from Table 24 on contents of TOP and/or NEXT registers.
<i>d</i>	Push short literal <i>d</i> from <i>dddd</i> field of instruction onto Parameter Stack (where <i>dddd</i> contains the actual value of the short literal). The original contents of TOP are pushed into NEXT , and the original contents of NEXT are pushed onto Stack Memory.
<i>D</i>	Push long literal <i>D</i> from next sequential location in program memory onto Parameter Stack. The original contents of TOP are pushed into NEXT , and the original contents of NEXT are pushed onto Stack Memory.
<i>R</i>	Perform a Return From Subroutine if bit = 1.
<i>x</i>	Bit fields containing x's are ignored by the processor.

TABLE 10. INSTRUCTION REGISTER BIT FIELDS (BY FUNCTION)

FUNCTION CODE	DEFINITION
<i>ggggg</i>	Address field for ASIC Bus locations
<i>uuuuu</i>	Address field for User Space memory locations
<i>cccc</i> <i>aaa</i>	ALU functions (see Table 23)
<i>dddd</i>	Short literals (containing a value from 0 to 31)
<i>ssss</i>	Shift Functions (see Table 24)

TABLE 11. RTX 2001A **I** AND **PC** ACCESS OPERATIONS*

OPERATION (g-read, g-write)	RETURN BIT VALUE	ASIC ADDRESS ggggg	REGISTER	FUNCTION
Read mode	0	00000	I	Pushes the contents of I into TOP (with no pop of the Return Stack)
Read mode	1	00000	I	Pushes the contents of I into TOP , then performs a Subroutine Return
Write mode	0	00000	I	Pops the contents of TOP into I (with no push of the Return Stack)
Write mode	1	00000	I	Performs a Subroutine Return, then pushes the contents of TOP into I
Read mode	0	00001	I	Pushes the contents of I into TOP , popping the Return Stack
Read mode	1	00001	I	Pushes the contents of I into TOP without popping the Return Stack, then executes the Subroutine Return
Write mode	0	00001	I	Pushes the contents of TOP into I popping the Parameter Stack
Write mode	1	00001	I	Performs a Subroutine Return, then pushes the contents of TOP into I
Read mode	0	00010	I	Pushes the contents of I shifted left by one bit, into TOP (the Return Stack is not popped)
Read mode	1	00010	I	Pushes the contents of I shifted left by one bit, into TOP (the Return Stack is not popped), then performs a Subroutine Return
Write mode	0	00010	I	Pushes the contents of TOP into I as a "stream" count, indicating that the next instruction is to be performed a specified number of times; the Parameter Stack is popped
Write mode	1	00010	I	Performs a Subroutine Return, then pushes the stream count into I
Read mode	0	00111	PC	Pushes the contents of PC into TOP
Read mode	1	00111	PC	Pushes the contents of PC into TOP , then performs a Subroutine Return
Write mode	0	00111	PC	Performs a Subroutine Call to the address contained in TOP , popping the Parameter Stack
Write mode	1	00111	PC	Pushes the contents of TOP onto the Return Stack before executing the Subroutine Return

* See the RTX Programmer's Reference Manual for a complete listing of typical software functions.

TABLE 12. 2001A RESERVED I/O OPCODES

INSTRUCTION CODE												OPERATION				
15	14	13	12	11	10	9	8	7	6	5	4	3	2	1	0	
1	0	1	1	0	0	0	0	1	0	R	0	1	1	0	1	Select DPR
1	0	1	1	0	0	0	0	0	0	R	0	1	1	0	1	Select CPR
1	0	1	1	0	0	0	0	1	0	R	1	0	0	0	0	Set SOFTINT
1	0	1	1	0	0	0	0	0	0	R	1	0	0	0	0	Clear SOFTINT
1	0	1	1	0	0	0	0	1	0	R	1	0	1	1	0	Increment RX
1	0	1	1	0	0	0	0	0	0	R	1	0	1	1	0	Decrement RX

TABLE 13. SUBROUTINE CALL INSTRUCTIONS

INSTRUCTION CODE												OPERATION				
15	14	13	12	11	10	9	8	7	6	5	4	3	2	1	0	
0	a	a	a	a	a	a	a	a	a	a	a	a	a	a	a	Call word address aaaa aaaa aaaa aaa0, in the page indicated by CPR . This address is produced when the processor performs a left shift on the address in the instruction code.

Subroutine Call Bit
(Bit 15 = 0: Call,
Bit 15 = 1: No Call)

TABLE 14. SUBROUTINE RETURN

INSTRUCTION CODE																OPERATION
15	14	13	12	11	10	9	8	7	6	5	4	3	2	1	0	
-	-	-	-	-	-	-	-	-	-	R	-	-	-	-	-	Return from subroutine

Subroutine Return Bit*
 (Bit 5, R = 0: No return
 R = 1: Return)

* Does not apply to Subroutine Call or Branch Instructions. A Subroutine Return can be combined with any other instruction (as implied here by hyphens).

TABLE 15. BRANCH INSTRUCTIONS

INSTRUCTION CODE																OPERATION
15	14	13	12	11	10	9	8	7	6	5	4	3	2	1	0	
1	0	0	0	0	b	b	a	a	a	a	a	a	a	a	a	DROP and branch if TOP = 0
1	0	0	0	1	b	b	a	a	a	a	a	a	a	a	a	Branch if TOP = 0
1	0	0	1	0	b	b	a	a	a	a	a	a	a	a	a	Unconditional branch
1	0	0	1	1	b	b	a	a	a	a	a	a	a	a	a	Branch and decrement PC if PC ≠ 0; Pop PC if PC = 0

Branch Address* _____

* See the Programmer's Reference Manual for further information regarding the branch address field.

TABLE 16. REGISTER AND I/O ACCESS INSTRUCTIONS

INSTRUCTION CODE																OPERATION
15	14	13	12	11	10	9	8	7	6	5	4	3	2	1	0	
1	0	1	1	0	0	0	i	0	0	R	g	g	g	g	g	<i>g-read</i> DROP inv
1	0	1	1	1	1	1	i	0	0	R	g	g	g	g	g	<i>g-read</i> inv
1	0	1	1	c	c	c	c	0	0	R	g	g	g	g	g	<i>g-read</i> OVER alu-op
1	0	1	1	0	0	0	i	1	0	R	g	g	g	g	g	DUP <i>g-write</i> inv
1	0	1	1	1	1	1	i	1	0	R	g	g	g	g	g	<i>g-write</i> inv
1	0	1	1	c	c	c	c	1	0	R	g	g	g	g	g	<i>g-read</i> SWAP alu-op

TABLE 17. SHORT LITERAL INSTRUCTIONS

INSTRUCTION CODE																OPERATION
15	14	13	12	11	10	9	8	7	6	5	4	3	2	1	0	
1	0	1	1	0	0	0	i	x	1	R	d	d	d	d	d	d DROP inv
1	0	1	1	1	1	1	i	0	1	R	d	d	d	d	d	d inv
1	0	1	1	c	c	c	c	0	1	R	d	d	d	d	d	d OVER alu-op
1	0	1	1	1	1	1	i	1	1	R	d	d	d	d	d	d SWAP DROP inv
1	0	1	1	c	c	c	c	1	1	R	d	d	d	d	d	d SWAP alu-op

TABLE 18. LONG LITERAL INSTRUCTIONS

INSTRUCTION CODE										OPERATION							
15	14	13	12	11	10	9	8	7	6	5	4	3	2	1	0	(1ST CYCLE)	(2ND CYCLE)
1	1	0	1	0	0	0	i	x	0	R	x	x	x	x	x	D SWAP	inv
1	1	0	1	1	1	1	i	0	0	R	x	x	x	x	x	D SWAP	SWAP inv
1	1	0	1	c	c	c	c	0	0	R	x	x	x	x	x	D SWAP	SWAP OVER alu-op
1	1	0	1	1	1	1	i	1	0	R	x	x	x	x	x	D SWAP	DROP inv
1	1	0	1	c	c	c	c	1	0	R	x	x	x	x	x	D SWAP	alu-op

TABLE 19. MEMORY ACCESS INSTRUCTIONS

INSTRUCTION CODE										OPERATION							
15	14	13	12	11	10	9	8	7	6	5	4	3	2	1	0	(1ST CYCLE)	(2ND CYCLE)
1	1	1	s	0	0	0	i	0	0	R	x	x	x	x	x	<i>m-read</i> SWAP	inv
1	1	1	s	1	1	1	i	0	0	R	x	x	x	x	x	<i>m-read</i> SWAP	SWAP inv
1	1	1	s	c	c	c	c	0	0	R	x	x	x	x	x	<i>m-read</i> SWAP	SWAP OVER alu-op
1	1	1	s	0	0	0	p	0	1	R	x	x	x	x	x	{SWAP DROP} DUP <i>m-read</i> SWAP	NOP
1	1	1	s	1	1	1	p	0	1	R	d	d	d	d	d	{SWAP DROP} <i>m-read d</i>	NOP
1	1	1	s	a	a	a	p	0	1	R	d	d	d	d	d	{SWAP DROP} DUP <i>m-read</i> SWAP d SWAP alu-op	NOP
1	1	1	s	0	0	0	i	1	0	R	x	x	x	x	x	OVER SWAP <i>m-write</i>	inv
1	1	1	s	1	1	1	i	1	0	R	x	x	x	x	x	OVER SWAP <i>m-write</i>	DROP inv
1	1	1	s	c	c	c	c	1	0	R	x	x	x	x	x	<i>m-read</i> SWAP	alu-op
1	1	1	s	0	0	0	p	1	1	R	x	x	x	x	x	{OVER SWAP} SWAP OVER <i>m-write</i>	NOP
1	1	1	s	1	1	1	p	1	1	R	d	d	d	d	d	{OVER SWAP} <i>m-write d</i>	NOP
1	1	1	s	a	a	a	p	1	1	R	d	d	d	d	d	{OVER SWAP} SWAP OVER <i>m-write d</i> SWAP alu-op	NOP

↑
 If s = 0, Memory is accessed by word
 If s = 1, Memory is accessed by byte

↑
 If (p = 0), perform either
 {SWAP DROP} or
 {OVER SWAP}

Note: SWAP d SWAP ≡ d ROT

TABLE 20. USER SPACE INSTRUCTIONS

INSTRUCTION CODE												OPERATION					
15	14	13	12	11	10	9	8	7	6	5	4	3	2	1	0		
1	1	0	0	0	0	0	i	0	0	R	u	u	u	u	u	<i>u-read</i> SWAP	inv
1	1	0	0	1	1	1	i	0	0	R	u	u	u	u	u	<i>u-read</i> SWAP	SWAP inv
1	1	0	0	c	c	c	c	0	0	R	u	u	u	u	u	<i>u-read</i> SWAP	SWAP OVER alu-op
1	1	0	0	0	0	0	i	1	0	R	u	u	u	u	u	DUP <i>u-write</i>	inv
1	1	0	0	1	1	1	i	1	0	R	u	u	u	u	u	DUP <i>u-write</i>	DROP inv
1	1	0	0	c	c	c	c	1	0	R	u	u	u	u	u	<i>u-read</i> SWAP	alu-op

TABLE 21. ALU FUNCTION INSTRUCTIONS

INSTRUCTION CODE												OPERATION					
15	14	13	12	11	10	9	8	7	6	5	4	3	2	1	0		
1	0	1	0	0	0	0	i	0	0	R	0	s	s	s	s		inv shift
1	0	1	0	1	1	1	i	0	0	R	0	s	s	s	s	DROP DUP	inv shift
1	0	1	0	c	c	c	c	0	0	R	0	s	s	s	s	OVER SWAP	alu-op shift
1	0	1	0	0	0	0	i	0	1	R	0	s	s	s	s	SWAP DROP	inv shift
1	0	1	0	1	1	1	i	0	1	R	0	s	s	s	s	DROP	inv shift
1	0	1	0	c	c	c	c	0	1	R	0	s	s	s	s		alu-op shift
1	0	1	0	0	0	0	i	1	0	R	0	s	s	s	s	SWAP DROP DUP	inv shift
1	0	1	0	1	1	1	i	1	0	R	0	s	s	s	s	SWAP	inv shift
1	0	1	0	c	c	c	c	1	0	R	0	s	s	s	s	SWAP OVER	alu-op shift
1	0	1	0	0	0	0	i	1	1	R	0	s	s	s	s	DUP	inv shift
1	0	1	0	1	1	1	i	1	1	R	0	s	s	s	s	OVER	inv shift
1	0	1	0	c	c	c	c	1	1	R	0	s	s	s	s	OVER OVER	alu-op shift

TABLE 22. STEP MATH* FUNCTIONS

INSTRUCTION CODE												OPERATION					
15	14	13	12	11	10	9	8	7	6	5	4	3	2	1	0		
1	0	1	0	-	-	-	-	-	-	-	1	-	-	-	-	(See the Programmer's Reference Manual)	

* These instructions perform multi-step math functions such as multiplication, division and square root functions. Use of either the Streamed instruction mode or masking of interrupts is recommended to avoid erroneous results when performing Step Math operations. The following is a summary of these operations:

Unsigned Multiplication:

- Load multiplier into **MD**
- Load multiplicand into **NEXT**
- Load initial value of product (usually 0) into **TOP**
- Clear Carry Bit by executing opcode B8C0
- Execute opcode A89CH 16 times (streamed mode)

Signed Multiplication:

- Load multiplier into **MD**
- Load multiplicand into **NEXT**
- Load initial value of product (usually 0) into **TOP**
- Clear Carry Bit by executing opcode B8C0
- Execute opcode A89DH 15 times
- Execute opcode A49DH 1 time

Unsigned Division:

- Load dividend into **TOP** and **NEXT**
- Load divisor into **MD**
- Execute single step form of D2* instruction 1 time
- Execute opcode A41A 1 time
- Execute opcode A45A 14 times
- Execute opcode A458 1 time
- The quotient is in **NEXT**, the remainder in **TOP**

Square Root Operations:

- Load value into **TOP** and **NEXT**
- Load 8000H into **SR**
- Load 0 into **MD**
- Execute single step form of D2* instruction 1 time
- Execute opcode A51A 1 time
- Execute opcode A55A 14 times
- Execute opcode A558 1 time
- The root is in **NEXT**, the remainder in **TOP**

TABLE 23. ALU LOGIC FUNCTIONS/OPCODES

cccc	aaa	FUNCTION
0010	001	AND
0011		NOR
0100	010	SWAP -
0101		SWAP - c With Borrow
0110	011	OR
0111		NAND
1000	100	+
1001		+c With Carry
1010	101	XOR
1011		XNOR
1100	110	-
1101		-c With Borrow

TABLE 24. SHIFT FUNCTIONS

SHIFT ssss	NAME	FUNCTION	STATUS OF C	TOP REGISTER			NEXT REGISTER		
				T15	Tn	T0	N15	Nn	N0
0000		No Shift	CY	Z15	Zn	Z0	TN15	TNn	TN0
0001	0<	Sign extend	CY	Z15	Z15	Z15	TN15	TNn	TN0
0010	2*	Arithmetic Left Shift	Z15	Z14	Zn-1	0	TN15	TNn	TN0
0011	2*c	Rotate Left	Z15	Z14	Zn-1	CY	TN15	TNn	TN0
0100	cU2/	Right Shift Out of Carry	0	CY	Zn+1	Z1	TN15	TNn	TN0
0101	c2/	Rotate Right Through Carry	Z0	CY	Zn+1	Z1	TN15	TNn	TN0
0110	U2/	Logical Right Shift	0	0	Zn+1	Z1	TN15	TNn	TN0
0111	2/	Arithmetic Right Shift	Z15	Z15	Zn+1	Z1	TN15	TNn	TN0
1000	N2*	Arithmetic Left Shift of NEXT	CY	Z15	Zn	Z0	TN14	TNn-1	0
1001	N2*c	Rotate NEXT Left	CY	Z15	Zn	Z0	TN14	TNn-1	CY
1010	D2*	32-bit Arithmetic Left Shift	Z15	Z14	Zn-1	TN15	TN14	TNn-1	0
1011	D2*c	32-bit Rotate Left	Z15	Z14	Zn-1	TN15	TN14	TNn-1	CY
1100	cUD2/	32-bit Right Shift Out of Carry	0	CY	Zn+1	Z1	Z0	TNn+1	TN1
‡ 1101	cD2/	32-bit Rotate Right Through Carry	TN0	CY	Zn+1	Z1	Z0	TNn+1	TN1
1110	UD2/	32-bit Logical Right Shift	0	0	Zn+1	Z1	Z0	TNn+1	TN1
1111	D2/	32-bit Arithmetic Right Shift	Z15	Z15	Zn+1	Z1	Z0	TNn+1	TN1

‡ See the Programmer's Reference Manual

Where: T15 -Most significant bit of **TOP**
 Tn -Typical bit of **TOP**
 T0 -Least significant bit of **TOP**
 N15 -Most significant bit of **NEXT**
 Nn -Typical bit of **NEXT**
 N0 -Least significant bit of **NEXT**
 C -Carry bit
 CY -Carry bit before operation
 Zn -ALU output
 Z15 -Most significant bit 15 of ALU output
 TNn -Original value of typical bit of **NEXT**

Specifications RTX 2001A

Absolute Maximum Ratings

Supply Voltage	+8.0V	Gate Count	16,700
Input, Output, or I/O Voltage Applied ...	GND - 0.5V to VCC + 0.5V	Junction Temperature	+175°C
Storage Temperature Range	-65°C to +150°C	Lead Temperature (Soldering, Ten Seconds)	+300°C
Maximum Package Power Dissipation	2 Watts		
θ_{ja}	41°C/W (PGA Package)		
θ_{jc}	17°C/W (PGA Package)		

CAUTION: Stresses above those listed in the "Absolute Maximum Ratings" may cause permanent damage to the device. This is a stress only rating and operation of the device at these or any other conditions above those indicated in the operation section of the specification is not implied.

Operating Temperature Range:

RTX 2001A (Industrial)	-40°C to +85°C
RTX 2001A (Commercial)	0°C to +70°C

Operating Conditions

Operating Voltage Range	+4.5V to +5.5V
Maximum Rise and Fall Times For EI5-EI3	20ns

D.C. Electrical Specifications

VCC = 5V, ±10%, T_A = -40°C to +85°C (Industrial) Temperature Range
VCC = 5V, ±5%, T_A = 0°C to +70°C (Commercial) Temperature Range

SYMBOL	PARAMETER	MIN	MAX	UNITS	COMMENTS	
VIH	Logical One Input Voltage	NMI, RESET, ICLK	VCC x 0.7	-	V	Tested at VCC = 5.5V
		Other Inputs	2.0	-	V	Tested at VCC = 5.5V
VIL	Logical Zero Input Voltage	-	0.8	V	Tested at VCC = 4.5V	
VOH	High Output Voltage		3.5	-	V	IOH = -4mA, VCC = 4.5V
			VCC - 0.4	-	V	IOH = -100µA, VCC = 4.5V
VOL	Low Output Voltage	-	0.4	V	IOL = 4mA, VCC = 4.5V	
II	Input Leakage Current	-1	1	µA	VI = VCC or GND, VCC = 5.5V	
IIO	I/O Leakage Current	-10	10	µA	VO = VCC or GND, VCC = 5.5V	
ICCSB	Standby Power Supply Current	-	500	µA	VI = VCC or GND (Note1)	
ICCOP	Operating Power Supply Current	-	10	mA	VI = VCC or GND; f (ICLK) = 1MHz; Outputs Unloaded (IO = 0); (Note 2)	

NOTES: 1. Typical ICCSB: 10µA. The RTX 2001A is a static CMOS part. Therefore ICCSB > 0 is due to leakage currents.

2. Operating supply current is proportional to frequency. Typical ICCOP: 5mA/MHz.

Capacitance (T_A = +25°C; All measurements referred to device GND)

SYMBOL	PARAMETER	TYP	UNITS	TEST CONDITIONS
CI	Input Capacitance	10	pF	f = 1MHz
CIO	I/O Capacitance	10	pF	f = 1MHz

Specifications RTX 2001A

A.C. Electrical Specifications $V_{CC} = 5V, \pm 10\%$, $T_A = -40^{\circ}C$ to $+85^{\circ}C$ (Industrial) Temperature Range
 $V_{CC} = 5V, \pm 5\%$, $T_A = 0^{\circ}C$ to $+70^{\circ}C$ (Commercial) Temperature Range

CLOCK, WAIT AND TIMER TIMING (Notes 1 and 2)

SYMBOL	PARAMETER	8MHz		10MHz		UNITS	COMMENTS
		MIN	MAX	MIN	MAX		
REQUIREMENTS							
t1	ICLK Period	62	-	50	-	ns	
t2	ICLK High Time	24	-	20	-	ns	
t3	ICLK Low Time	24	-	20	-	ns	
t4	WAIT Set Up Time	5	-	5	-	ns	
t5	WAIT Hold Time	3	-	3	-	ns	
t6	EI High to EI High	t1x4	-	t1x4	-	ns	External Clock/Timer Input
t7	EI High Time	10	-	10	-	ns	External Clock/Timer Input
t8	EI Low Time	10	-	10	-	ns	External Clock/Timer Input
RESPONSES							
t11	ICLK to TCLK High	3	25	3	24	ns	
t12	TCLK Low Time	52	-	40	-	ns	Note 3
t13	TCLK High Time	64	-	52	-	ns	Note 3
t15	ICLK to PCLK High	3	25	3	25	ns	
t16	PCLK Low Time	52	-	40	-	ns	Note 3
t17	PCLK High Time	64	-	52	-	ns	Note 3
t19	ICLK to TCLK Low	-	35	-	32	ns	
t20	ICLK to PCLK Low	-	30	-	26	ns	

- NOTES: 1. High and low input levels for A.C. test:
 ICLK, NMI, and RESET: 4.0V and 0.4V
 Other Inputs: 2.4V and 0.4V
 2. Output load: 100pF.
 3. Tested with $t_1 = t_1(\text{min})$. For $t_1 > t_1(\text{min})$,
 add $t_1 - t_1(\text{min})$.

Specifications RTX 2001A

A.C. Electrical Specifications (Continued) VCC = 5V, $\pm 10\%$, T_A = -40°C to +85°C (Industrial) Temperature Range
VCC = 5V, $\pm 5\%$, T_A = 0°C to +70°C (Commercial) Temperature Range

MEMORY BUS TIMING (Notes 1 and 2)

SYMBOL	PARAMETER	8MHz		10MHz		UNITS	COMMENTS
		MIN	MAX	MIN	MAX		
REQUIREMENTS							
t21	MD Setup Time	16	-	12	-	ns	Read Cycle
t22	MD Hold Time	4	-	4	-	ns	Read Cycle
RESPONSES							
t26	PCLK to MA Valid	-	51	-	43	ns	Note 4
t28	MA Hold Time	20	-	20	-	ns	Note 5
t29	PCLK to MR/ \overline{W} , UDS, LDS, NEW and BOOT Valid	-	50	-	44	ns	Note 4
t31	MR/ \overline{W} , UDS, LDS, NEW and BOOT Hold Time	20	-	20	-	ns	Note 5
t32	PCLK to MD Valid	-	16	-	14	ns	Write Cycle
t33	MD Hold Time	20	-	20	-	ns	Write Cycle, Note 5
t34	MD Enable Time	-2	-	-2	-	ns	Write Cycle, Note 3
t35	PCLK to MD Disable Time	-	50	-	44	ns	Write Cycle, Notes 3, 4

- NOTES: 1. High and low input levels for A.C. test:
ICLK, NMI, and RESET: 4.0V and 0.4V
Other Inputs: 2.4V and 0.4V
2. Output load: 100pF.
3. Output enable and disable times are characterized only.
4. Tested with t₁ at specified minimum and t₂ = 0.5*t₁.
For t₂ > 0.5*t₁(min), add t₂ - (0.5*t₁(min)) to this specification.
5. Tested with t₁ at specified minimum and t₂ = 0.5*t₁.
For t₂ < 0.5*t₁(min), subtract (0.5*t₁(min)) - t₂ from this specification.

Specifications RTX 2001A

A.C. Electrical Specifications (Continued) VCC = 5V, ±10%, T_A = -40°C to +85°C (Industrial) Temperature Range
VCC = 5V, ±5%, T_A = 0°C to +70°C (Commercial) Temperature Range

ASIC BUS AND INTERRUPT TIMING (Notes 1 and 2)

SYMBOL	PARAMETER	8MHz		10MHz		UNITS	COMMENTS
		MIN	MAX	MIN	MAX		
REQUIREMENTS							
t40	GD Read Setup to PCLK	45	-	37	-	ns	Read Cycle
t41	GD Read Setup to $\overline{\text{GIO}}$	46	-	37	-	ns	Read Cycle
t42	GD Read Hold from $\overline{\text{GIO}}$	0	-	0	-	ns	Read Cycle
t43	GD Read Hold from PCLK	0	-	0	-	ns	Read Cycle
t44	EI/NMI Setup Time	22	-	20	-	ns	INT/NMI Cycle
t46	INTSUP Setup Time	22	-	20	-	ns	
t47	INTSUP Hold Time	0	-	0	-	ns	
RESPONSES							
t48	PCLK High to $\overline{\text{GIO}}$ Low	52	-	46	-	ns	Note 6
t49	$\overline{\text{GIO}}$ Low Time	52	-	40	-	ns	Note 6
t50	ICLK High to $\overline{\text{GIO}}$ Low	-	35	-	30	ns	
t51	ICLK High to $\overline{\text{GIO}}$ High	-	35	-	32	ns	
t52	PCLK to GA Valid	-	49	-	40	ns	Note 4
t54	$\overline{\text{GIO}}$ to GA Hold Time	12	-	12	-	ns	Note 5
t56	PCLK to GR/ $\overline{\text{W}}$ Valid	-	50	-	42	ns	Note 4
t58	$\overline{\text{GIO}}$ to GR/ $\overline{\text{W}}$ Hold Time	12	-	12	-	ns	Note 5
t61	GD Enable Time	-2	-	-2	-	ns	Write Cycle, Note 3
t62	GD Valid Time	-	16	-	14	ns	Write Cycle
t63	$\overline{\text{GIO}}$ to GD Hold Time	12	-	12	-	ns	Write Cycle, Note 5
t65	$\overline{\text{GIO}}$ to GD Disable Time	-	50	-	44	ns	Write Cycle, Notes 3, 4
t67	PCLK to INTA High Time	-	25	-	25	ns	INTA Cycle
t68	INTA Hold Time	0	-	0	-	ns	INTA Cycle

NOTES: 1. High and low input levels for A.C. test:
ICLK, NMI and RESET: 4.0V and 0.4V
Other Inputs: 2.4V and 0.4V

2. Output load: 100pF.

3. Output enable and disable times are characterized only.

4. Tested with t₁ at specified minimum and t₂ = 0.5*t₁.
For t₂ > 0.5*t₁(min), add t₂ - (0.5*t₁(min)) to this specification.

5. Tested with t₁ at specified minimum and t₂ = 0.5* t₁.
For t₂ < 0.5*t₁(min), subtract (0.5*t₁(min)) - t₂ from this specification.

6. Tested with t₁ = t₁(min). For t₁ > t₁(min), add t₁ - t₁(min).

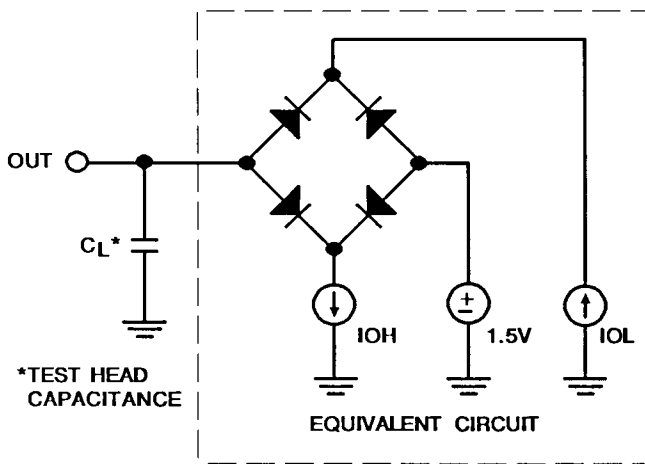
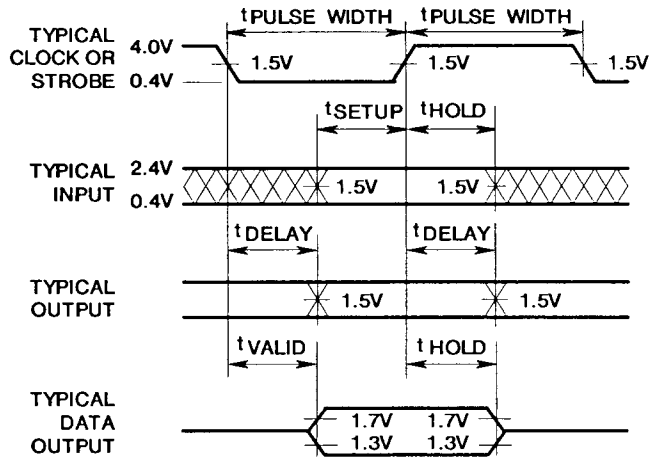

FIGURE 21. TEST CIRCUIT



Note: Values Are Subject to Change
 FIGURE 22. A.C. DRIVE AND MEASURE POINTS - CLK INPUT

NOTE: For A.C. testing input rise and fall times are driven at 1 volt/ns

Timing Diagrams

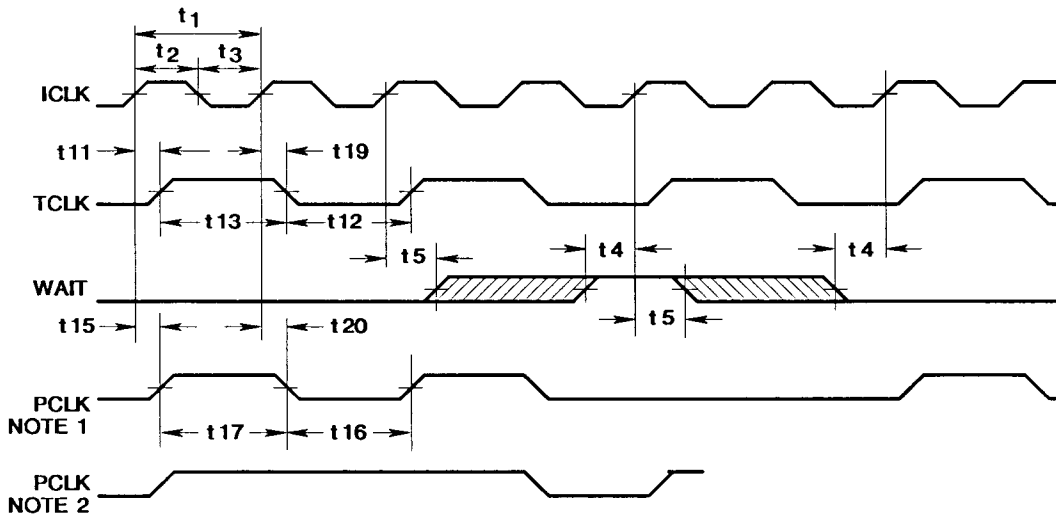

NOTES:

1. NORMAL CYCLE: This waveform describes a normal PCLK cycle and a PCLK cycle with a Wait state.
2. EXTENDED CYCLE: This waveform describes a PCLK cycle for a USER memory access or an Interrupt Acknowledge cycle when the CYCEXT bit is set. To ensure compatibility with future parts, Wait states should not be used with extended cycles.

FIGURE 23. CLOCK AND WAIT TIMING

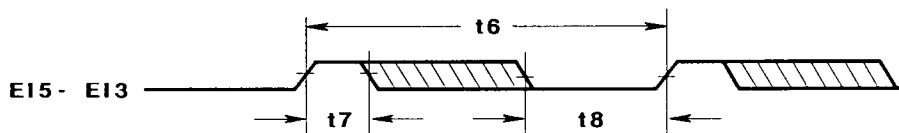
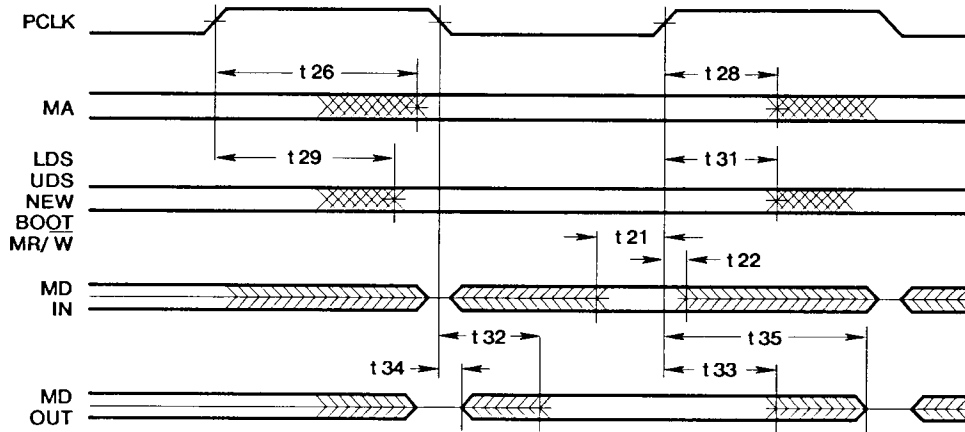

FIGURE 24. TIMER/COUNTER TIMING

Timing Diagrams (Continued)



- NOTES: 1. If both LDS and UDS are low, no memory access is taking place in the current cycle. This only occurs during streamed instructions that do not access memory.
 2. During a streamed single cycle instruction, the Memory Data Bus is driven by the processor.

FIGURE 25. MEMORY BUS TIMING

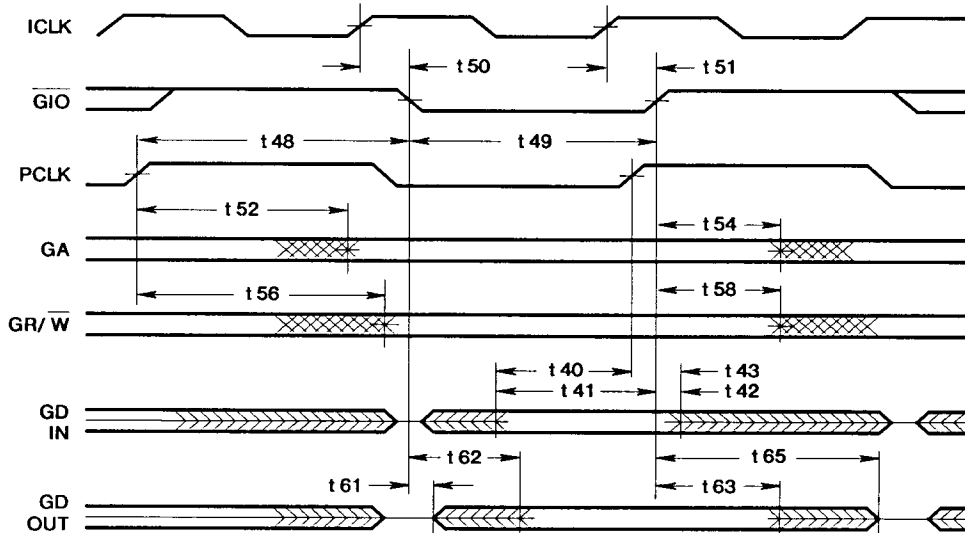

- NOTES: 1. $\overline{\text{GIO}}$ remains high for internal ASIC bus cycles.
 2. $\overline{\text{GR/W}}$ goes low and GD is driven for all ASIC write cycles, including internal ones.
 3. During non-ASIC write cycles, GD is not driven by the RTX2001A. Therefore, it is recommended that all GD pins be pulled to VCC or GND to minimize power supply current and noise.

FIGURE 26. ASIC BUS TIMING

Timing Diagrams (Continued)

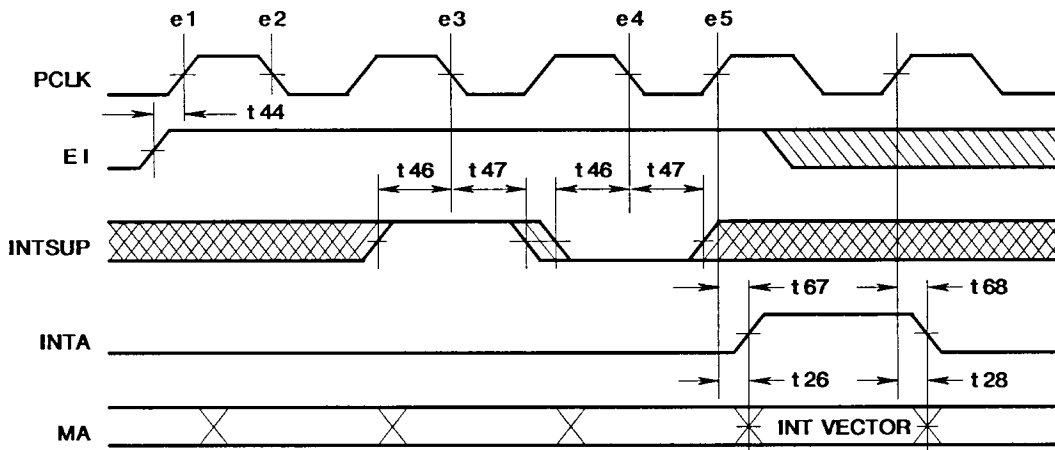

FIGURE 27. INTERRUPT TIMING: WITH INTERRUPT SUPPRESSION

NOTES: 1. Events in an interrupt sequence are as follows:

- e1. The Interrupt Controller samples the interrupt request inputs on the rising edge of PCLK. If NMI rises between e1 and e5, the interrupt vector will be for NMI.
- e2. If any interrupt requests were sampled, the Interrupt Controller issues an interrupt request to the core on the falling edge of PCLK.
- e3. The core samples the state of the interrupt requests from the Interrupt Controller on the falling edge of PCLK. If INTSUP is high, maskable interrupts will not be detected at this time.
- e4. When the core samples an interrupt request on the falling edge of PCLK, an Interrupt Acknowledge cycle will begin on the next rising edge of PCLK.
- e5. Following the detection of an interrupt request by the core, an Interrupt Acknowledge cycle begins. The interrupt vector will be based on the highest priority interrupt request active at this time.

- 2. t44 is only required to determine when the Interrupt Acknowledge cycle will occur.
- 3. Interrupt requests should be held active until the Interrupt Acknowledge cycle for that interrupt occurs.

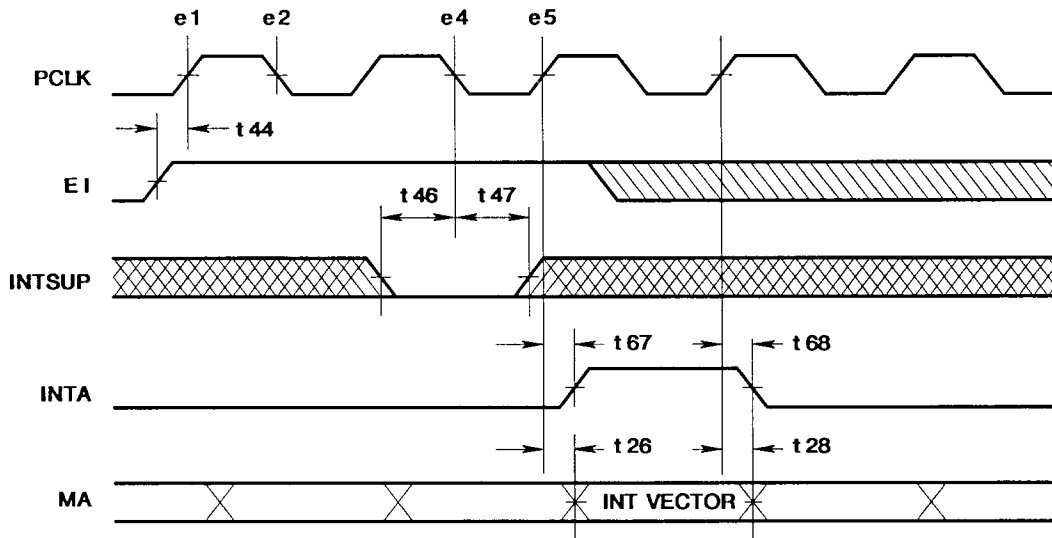

FIGURE 28. INTERRUPT TIMING: WITH NO INTERRUPT SUPPRESSION

Timing Diagrams (Continued)

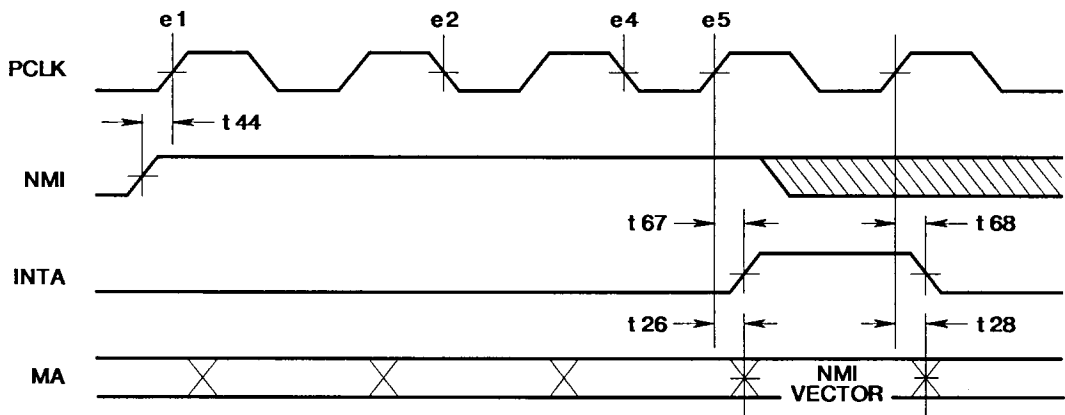

FIGURE 29. NON-MASKABLE INTERRUPT TIMING

NOTES: 1. Events in an interrupt sequence are as follows:

- e1. The Interrupt Controller samples the interrupt request inputs on the rising edge of PCLK. If NMI rises between e1 and e5, the interrupt vector will be for NMI.
- e2. If any interrupt requests were sampled, the Interrupt Controller issues an interrupt request to the core on the falling edge of PCLK.
- e3. The core samples the state of the interrupt requests from the Interrupt Controller on the falling edge of PCLK. If INTSUP is high, maskable interrupts will not be detected at this time.
- e4. When the core samples an interrupt request on the falling edge of PCLK, an Interrupt Acknowledge cycle will begin on the next rising edge of PCLK.
- e5. Following the detection of an interrupt request by the core, an Interrupt Acknowledge cycle begins. The interrupt vector will be based on the highest priority interrupt request active at this time.

2. t44 is only required to determine when the Interrupt Acknowledge cycle will occur.

3. Interrupt requests should be held active until the Interrupt Acknowledge cycle for that interrupt occurs.

RTX 2001A

Packaging

84 PIN GRID ARRAY

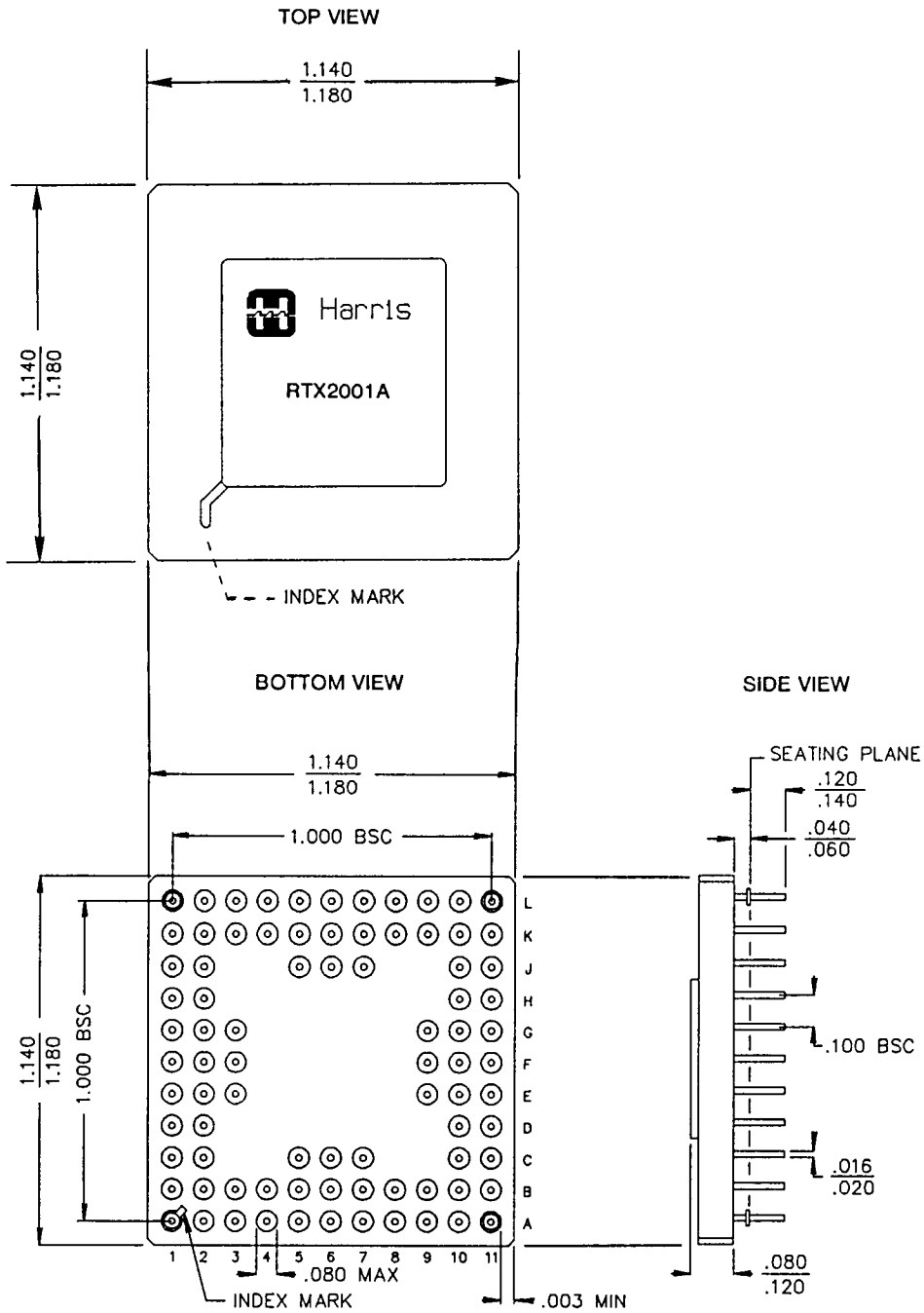

NOTE: All Dimensions are $\frac{\text{Min}}{\text{Max}}$, Dimensions are in inches.

Packaging (Continued)

84 LEAD PLCC

TOP VIEW

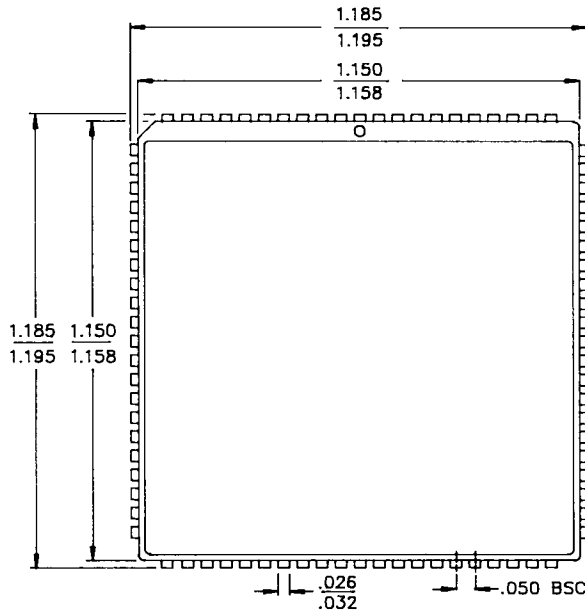

SIDE VIEW

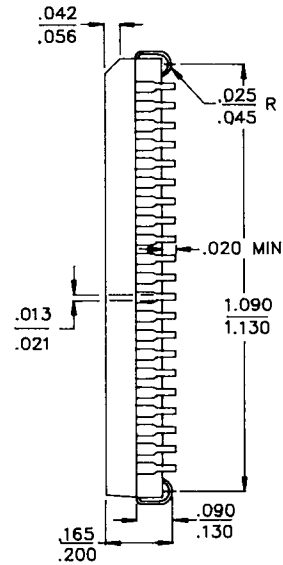

NOTES:
 1. BODY SIZE DIMENSIONS DO NOT INCLUDE MOLD FLASH

NOTE: All Dimensions are $\frac{\text{Min}}{\text{Max}}$, Dimensions are in inches.

Ordering Information

COMMERCIAL/INDUSTRIAL

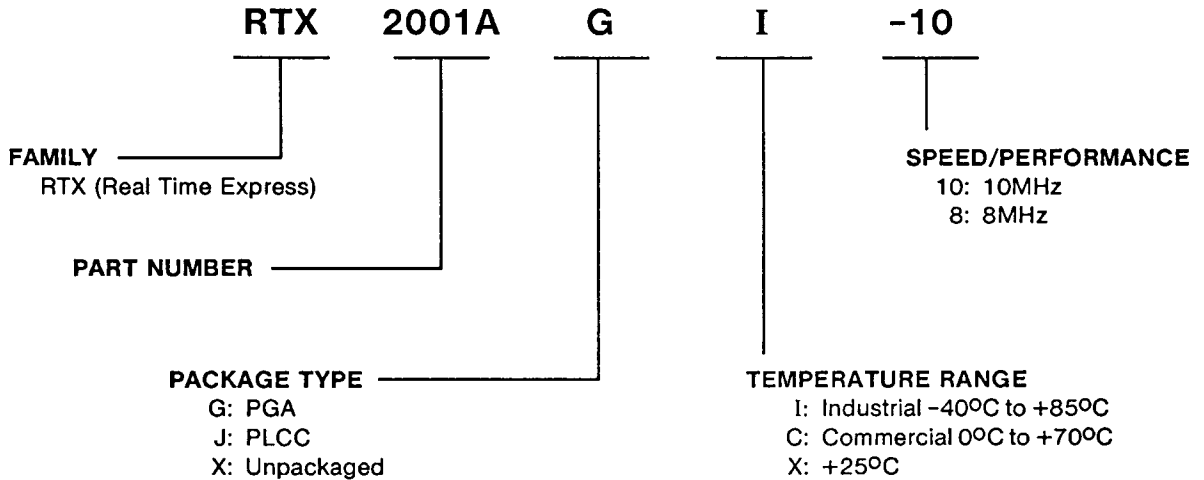

Harris Semiconductor products are sold by description only. Harris Semiconductor reserves the right to make changes in circuit design and/or specifications at any time without notice. Accordingly, the reader is cautioned to verify that data sheets are current before placing orders. Information furnished by Harris is believed to be accurate and reliable. However, no responsibility is assumed by Harris or its subsidiaries for its use; nor for any infringements of patents or other rights of third parties which may result from its use. No license is granted by implication or otherwise under any patent or patent rights of Harris or its subsidiaries.

Index

	Page
ALU, Description	17-18
ALU, Functions	25-26
Buses: Address, Data	6
Instruction Set Information	21-26
Interface, ASIC Bus	18
Interface, Memory Bus	18
Interrupt Controller	15-17
Interrupt Sources, Priorities, Vectors	15
Memory Access	18-20
Operation, General	6
Ordering Information	36
Packaging Information	35-36
Pin/Signal Assignments	3
Pinouts	2
Registers, ASIC Addresses	11
Registers, Bit Assignments	7-10
Registers, Initialization	11
Registers, Internal To Core	7
Registers, On-Chip Peripheral	7-10
Signal Descriptions, I/O	3-4
Software Information	20
Specifications, A.C.	28-30
Specifications, D.C.	27
Specifications, Maximum Ratings	27
Specifications, Operating Conditions	27
Stacks, Architecture	12
Stacks, Controllers	12-14
Subroutine Calls And Returns	20
Timers/Counters	14
Timing Diagrams	31-34

Sales Offices

U.S. HEADQUARTERS
 Harris Semiconductor
 1301 Woody Burke Road
 Melbourne, Florida 32902
 TEL: (407) 724-3739

EUROPEAN HEADQUARTERS
 Harris Semiconductor
 Mercure Centre
 Rue de la Fusse 100
 Brussels, Belgium 1130
 TEL: (32) 246-2201

SOUTH ASIA
 Harris Semiconductor H.K. Ltd
 13/F Fourseas Building
 208-212 Nathan Road
 Tsimshatsui, Kowloon
 Hong Kong
 TEL: (852) 3-723-6339

NORTH ASIA
 Harris K.K.
 Shinjuku NS Bldg. Box 6153
 2-4-1 Nishi-Shinjuku
 Shinjuku-Ku, Tokyo 163 Japan
 TEL: 81-3-345-8911



COMMERCIAL PRODUCTS GROUP