

NOTES:

- 1 BOOT :
HEAT SHRINKABLE, RADIATION CROSSLINKED MODIFIED POLYVINYLIDENE FLUORIDE, TRANSPARENT BLUE
- 2 FLAT CABLE SEAL :
MODIFIED THERMOPLASTIC SEALANT
- 3 CONTACT :
COPPER COATED ALLOY WITH Sn63 SOLDER AND ROL1 FLUX PER ANSI/J-STD-004
- 4 CONTACT SEAL :
MODIFIED THERMOPLASTIC SEALANT
- 5 THIS TERMINATOR MAY BE USED TO CONNECT, BY SOLDERING, A FLAT CONDUCTOR CABLE OR PRINTED CIRCUIT BOARD TO A RIGID PRINTED CIRCUIT BOARD.
- 6. FOR INSTALLATION, REFER TO PROCEDURE RPIP-652-00-01.
- 7. USABLE FLAT CONDUCTOR CABLE: RAYCHEM TU-40-050-28B.
- 8 WEIGHT DOES NOT INCLUDE THE CARRIER STRIP.

REVISIONS			
LTR	DESCRIPTION	DATE	APPROVED
F	REVISED AND REDRAWN PER ECN #T-19866	6/2/95	HAGMANN
G	REVISED PER DCR# C040617	April/5/04	M.HIGGY
H	REVISED PER DCR# C060063	March/31/06	M.HIGGY

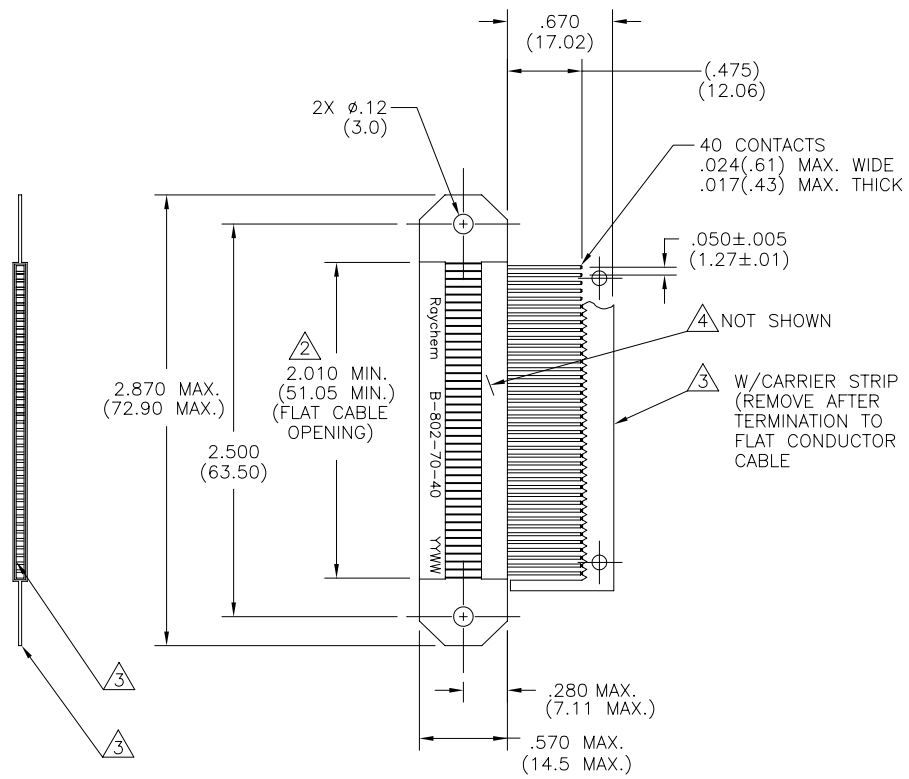

If this document is printed it becomes uncontrolled. Check for the latest revision

SPECIFICATION CONTROL DRAWING

© 2004-2006 Tyco Electronics Corporation. All rights reserved.

UNLESS OTHERWISE SPECIFIED DIMENSIONS ARE IN INCHES. METRIC DIMENSIONS ARE IN BRACKETS.		DRAWN JWELCH DATE 6/2/95					
DECIMALS .XXX ±.020 [.51 mm] .XX ±.XX [mm]		CHECKED R.H. DATE 6/2/95				TYCO ELECTRONICS 300 Constitution Drive Menlo Park, CA. 94025 USA	
ANGLE ± X°		APPROVED RHAGMANN DATE 6/2/95		TITLE		PCB TERMINATOR	
WEIGHT 8 lbs. [2.9 g] MAX.		APPROVED DATE		CAGE CODE: C 06090		DWG. NO. B-802-70-40	
THIRD ANGLE PROJECTION		CAD NAME C060063.DWG		DO NOT SCALE THIS DRAWING		SCALE NONE	
				SHEET 1		OF 1	